

Molecular chirality and chiral parameters

A. B. Harris,* Randall D. Kamien,[†] and T. C. Lubensky[‡]

Department of Physics and Astronomy, University of Pennsylvania, Philadelphia, Pennsylvania 19104

The fundamental issues of symmetry related to chirality are discussed and applied to simple situations relevant to liquid crystals. The authors show that any chiral measure of a geometric object is a pseudoscalar (invariant under proper rotations but changing sign under improper rotations) and must involve three-point correlations that only come into play when the molecule has at least four atoms. In general, a molecule is characterized by an infinite set of chiral parameters. The authors illustrate the fact that these parameters can have differing signs and can vanish at different points as a molecule is continuously deformed into its mirror image. From this it is concluded that handedness is not an absolute concept but depends on the property being observed. Within a simplified model of classical interactions, the chiral parameter of the constituent molecules that determines the macroscopic pitch of cholesterics is identified. [S0034-6861(99)00255-X]

CONTENTS

I. Introduction	1745
II. Chiral Parameters	1748
A. Chirality is the absence of symmetry	1748
B. Construction of pseudoscalars	1748
1. Nonpolar molecules	1749
2. Ferroelectric liquid crystals	1750
III. "Rubber Glove" Molecules	1751
IV. Prediction of the Cholesteric Pitch	1752
V. Discussion and Conclusion	1755
Acknowledgments	1755
Appendix: Expression for the Torque Field	1755
Glossary	1756
References	1756

I. INTRODUCTION

Since the birth of stereochemistry more than 150 years ago with Pasteur's discovery of handedness in molecules (Pasteur, 1848) interest in chiral molecules has continued unabated. The term chirality was first coined by Lord Kelvin (Thomson, 1893):

"I call any geometrical figure, or group of points, *chiral*, and say it has chirality if its image in a plane mirror, ideally realized, cannot be brought to coincide with itself."

Chirality permeates the entire fabric of the biological world. Indeed, life as we know it could not exist without chirality. The function of fundamental components of the cell such as actin, myosin, proteins, and lipids, relies upon their being chiral. The handedness of a molecule can affect its odor, potency, and toxicity. Thus the synthesis of a single enantiomer of a compound is crucial for the delivery of safe and effective pharmaceuticals and food additives.

Since chirality is the absence of inversion symmetry, a structure is either chiral or it is not. However, just as the

degree of order of a ferromagnet, which is either ordered or not ordered, can be quantified, so can the chirality of a structure. A major theme of this colloquium is the development of quantitative measures of chirality and its impact on physically measurable properties of materials. There is an agreed-upon convention for answering the question of whether or not a molecule is chiral. It involves identifying chiral carbons (to be discussed in more detail below) to which a handedness can be assigned via the Cahn-Ingold-Prelog rule (McMurry, 1992), which orders the chemical groups attached to the carbon according to their molecular weight. The identification of the handedness in this way, however, gives no indication of the magnitude, or even the sign of the optical rotatory power this molecule will exhibit in solution. Indeed the magnitude and sign of the rotatory power depends on wavelength (though it is usually quoted in handbooks for the D-line of Na). Rotatory power provides only one quantitative measure of chirality, which could be used, for instance, to assess whether one substance is more or less chiral than another. Similarly when a liquid crystal forms a cholesteric it is obviously chiral. It can be more or less chiral depending on whether the pitch is shorter or longer, respectively. There are many other such quantitative measures. In this colloquium, we shall define quantitative indices of chirality based on molecular geometry and show how they enter the determination of a particular observable, the pitch of a cholesteric liquid crystal.

Microscopic chiral constituents have a profound effect on the macroscopic structures they form, striking examples of which are common in liquid crystals (de Gennes and Prost, 1993). The simplest liquid crystalline phase is the nematic phase, characterized by long-range uniaxial orientational order of anisotropic molecules called nematogens, as shown in Fig. 1(a). The centers of mass of the constituent molecules are distributed homogeneously as in an isotropic fluid, but one of their anisotropy axes aligns, on average, along a common unit vector \mathbf{n} called the director. Strongly biaxial molecules (Fig. 2) can in principle condense into a biaxial rather than a uniaxial nematic phase with long-range biaxial orientational order (de Gennes and Prost, 1993). In this phase,

*Electronic address: harris@harris.physics.upenn.edu

[†]Electronic address: kamien@physics.upenn.edu

[‡]Electronic address: tom@physics.upenn.edu

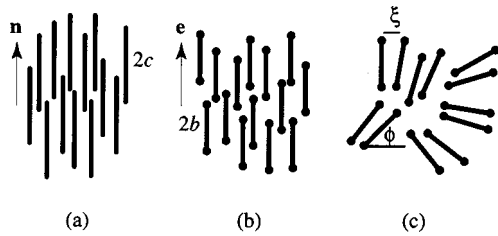

FIG. 1. Uniaxial and biaxial nematics. (a) Schematic representation of a nematic liquid crystal in which long molecular axes align on average along a spatially uniform director \mathbf{n} . The nematogens of this phase can be either uniaxial [like Fig. 2(a)] or biaxial [like Fig. 2(b)]. In the latter case, the long axis is the c axis of length $2c$. (b) Schematic representation of the plane perpendicular to \mathbf{n} in a biaxial nematic. The b axes of nematogens align on average along \mathbf{e} perpendicular to \mathbf{n} . (c) Schematic representation of the plane perpendicular to \mathbf{n} in a uniaxial nematic composed of biaxial molecules. There is no long-range biaxial order but there are short-range orientational correlations that persist out to a correlation length ξ . The angle ϕ measures the orientation of the “biaxial” axis of each molecule with respect to the x axis.

one molecular axis aligns along \mathbf{n} , and a second orthogonal axis aligns on average along a second vector \mathbf{e} perpendicular to \mathbf{n} as shown schematically in Fig. 1(b). Biaxial molecules can also condense into a uniaxial nematic phase with short-ranged biaxial correlations rather than long-range biaxial order, as depicted in Fig. 1(c).

If these nematogens are chiral or if chiral molecules are added to an achiral uniaxial nematic, the director \mathbf{n} will twist, creating the simplest twisted phase: the cholesteric or twisted nematic phase, the first liquid-crystalline phase to be discovered (Reinitzer, 1888). This phase is depicted schematically in Fig. 3. The director at position $\mathbf{x}=(x,y,z)$ rotates in a helical fashion:

$$\mathbf{n}(\mathbf{x}) = (\cos qz, \sin qz, 0). \quad (1)$$

In equilibrium the twist wave number q assumes a preferred value q_0 , which corresponds to a pitch $P \equiv 2\pi/q_0$. Typically, the pitch can vary from hundreds of nanometers to many microns or more, depending on the system. Cholesterics with pitches on the order of 500 nm

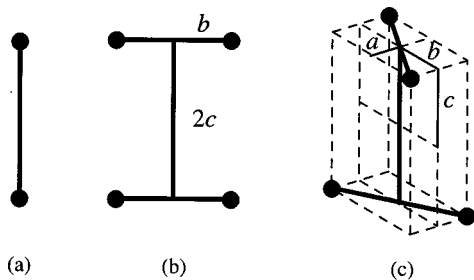

FIG. 2. Molecular models with decreasing symmetry. Representations of (a) linear, (b) biaxial planar, and (c) chiral molecules. The molecule in (c) is a twisted “H” obtained from (b) by twisting about the long molecular axis (c axis). It is both nonuniaxial and nonplanar, as required for a chiral molecule.

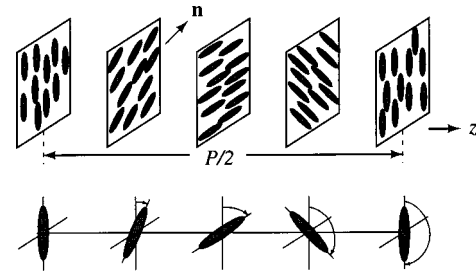

FIG. 3. Schematic representation of a cholesteric liquid crystal, showing the helical twisting pattern of the local director \mathbf{n} along the pitch axis (z in this case). The director rotates by π in half a pitch $P/2$.

Bragg scatter visible light and appear iridescent. If chirality is added to a *biaxial* nematic, a cholesteric structure similar to that shown in Fig. 3 results, though the local molecular order will be strongly biaxial. Other liquid-crystalline phases with macroscopic chiral structure include the blue phase, in which the director twists in all directions to produce a three-dimensional periodic crystal, and the smectic- C^* phase. The dipole moments of the molecules in the latter phase become ordered as a consequence of their chirality and make this phase ferroelectric. Technologies based on these ferroelectric liquid crystals show great promise for fast-switching, high-resolution displays.

Models of chiral molecules are shown in Fig. 4. Of particular importance in chemistry is the tetrahedrally coordinated molecule, shown schematically in Fig. 4(a), consisting of a central carbon atom with each of its four bonds connected to a different chemical unit. If any two of these chemical units are equivalent, then the molecule has a mirror plane and is not chiral. If all the chemical

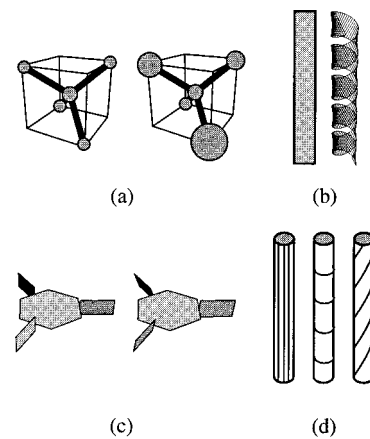

FIG. 4. Examples of chiral structures created from achiral ones: (a) Left, an achiral molecule in the shape of a tetrahedron with four equal masses at its vertices; right, a similar chiral molecule with four unequal masses at its vertices. (b) Left, an achiral planar sheet; right, a helix formed by twisting a sheet about a cylinder. (c) Left, an achiral propeller with all blades perpendicular to the hexagonal core; right, a chiral propeller with all blades rotated away from the normal to the hexagonal plane. (d) Left and middle, cylinder with achiral decorations; right, chiral cylinder with helical decorations.

units are different then the molecule is chiral and the central carbon atom is referred to as a chiral center. More complex molecules may have many such chiral centers. If all atoms of a molecule lie in a single plane, that plane is a mirror plane, and the molecule is achiral; therefore chiral molecules must be three dimensional. The converse does not hold: not all three-dimensional molecules are chiral. For instance, structures that have continuous rotational symmetry about an axis (C_∞) are not chiral. The simplest nonuniaxial structures have second-rank mass-moment tensors with three inequivalent principal axes and are biaxial. Figure 2 shows model linear, biaxial planar, and chiral molecules. The twisted "H" in Fig. 2(c) is both biaxial and chiral.

In spite of its practical importance, there is no universal quantitative description of molecular chirality, nor is there an accepted procedure for identifying the chiral part of an intermolecular interaction. As a result, only recently has real progress been made in addressing straightforward and apparently simple issues such as the relation between the cholesteric pitch and molecular geometry. Ideally one would like to introduce a parameter that measures the chiral strength or degree of chirality of a given molecule. A nonvanishing value of this parameter, which we shall refer to as a chiral strength parameter or simply a chiral parameter, would distinguish a chiral molecule from an achiral one, just as the dipole moment distinguishes a polar molecule from a nonpolar one. In addition, such a chiral parameter would play a crucial role in determining macroscopic chiral properties, such as the optical rotary power, the wave vector for cholesteric ordering, and other macroscopic chiral indices. Unfortunately, there appears to be no such simple description of chirality and chiral parameters. As we shall show, just as a charge distribution can be described by an infinite hierarchy of multipole moments, so a chiral molecule can be described by an infinite hierarchy of chiral parameters. If any one of these parameters is nonzero, then the molecule is chiral. Also, since different macroscopic properties will, in general, depend on different microscopic chiral parameters, we do not expect strong correlations between the various macroscopic manifestations of chirality.

Even if one were equipped with a complete understanding of the nature of interactions between chiral molecules, the calculation of macroscopic parameters like the cholesteric pitch would not be completely straightforward. An argument due to Straley (1974), illustrated in Fig. 5, makes it clear why molecular chirality causes macroscopic rotation: when two screwlike molecules are brought close together, their grooves interlock to produce a finite rotation angle $\Delta\theta$ between long molecular axes. A simple estimate of the pitch based on this picture is $P \approx (2\pi/\Delta\theta)l$ where l is the molecular diameter. Taking a rough estimate of $\Delta\theta \approx 10^\circ - 20^\circ$ and a molecular size of roughly 1 nm, one finds that $P \approx 10$ nm, two or three orders of magnitude smaller than typical pitches. Indeed some chiral systems (Fraden, 1995) are labeled nematic rather than cholesteric, presumably because their pitches are too long to be mea-

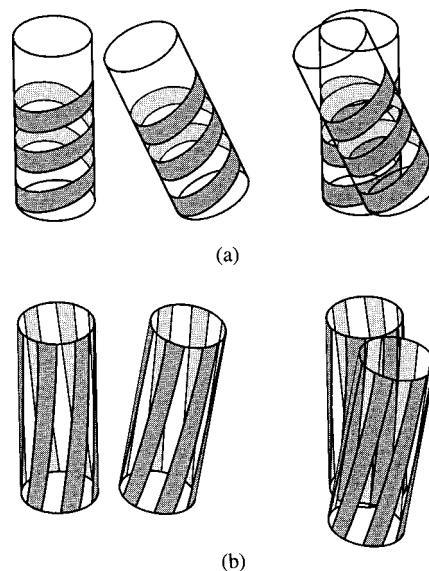

FIG. 5. This figure shows how steric interactions between two chiral molecules produce a net relative rotation of their long axes. The "barber pole" stripes on the model cylindrical molecules represent protrusions such as are found on a screw. If the protrusions on one molecule (the shaded regions) are forced to fit "hand in glove" into the grooves on another (the unshaded regions) then, as we show on the right, when one molecule is placed upon another, the protrusions on one molecule align with the grooves on the other. The result is that the long axes of the two molecules acquire a relative twist determined by the pitch of the stripes. In (a) we show molecules with a tight right-handed pitch as determined by the geometrical right-hand rule. The relative twist of two neighboring molecules is right handed according to the right-hand rule. (b) shows molecules with a weak right-handed pitch. The relative twist of neighboring molecules is now left handed. These examples show that the "handedness" of individual molecules does not determine the handedness of the collective structure.

sured experimentally. Thus a quantitatively correct calculation of the cholesteric pitch cannot be based solely on molecular parameters and presents a challenge to theorists. As we demonstrated previously (Harris, Kamien, and Lubensky, 1997), for central-force or steric models, q_0 vanishes (infinite pitch) unless biaxial correlations between the orientations of adjacent molecules (such as are illustrated in Fig. 1) are taken into account. Quantum interactions, however, do not require such correlations and hence can give a nonzero value of q_0 even within mean field theory.

The purpose of this colloquium is to present recent progress both in quantitatively characterizing molecular chirality and in calculating the cholesteric pitch from microscopic interactions. In Sec. II we start by making some naive qualitative comments about the nature of chiral symmetry. The central idea is that an achiral object has higher symmetry than a chiral one. We develop a systematic procedure for generating a countably infinite set of chiral molecular parameters that all vanish when the molecule is achiral. Next, in Sec. III, to illustrate our chiral parameters we consider a topological "rubber glove," a chiral structure that can be converted

to its mirror image via distortions through a continuum of intermediate states, all of which are chiral. This demonstration shows clearly that handedness is not an absolute concept, but depends on the property under consideration. In Sec. IV we describe a calculation of the cholesteric pitch from a classical model of central forces between atoms. This calculation shows that biaxial correlations play a critical role in determining the pitch P . In fact, if these biaxial correlations do not exist, each molecule rotates freely and appears, on average, uniaxial and thus achiral. In accord with our discussions of chiral parameters in Sec. II, we expect that other macroscopic chiral response functions, such as the rotatory power, will depend on other chiral structure parameters. Indeed, it is likely that an understanding of many such indices of molecular chirality is required to interpret the dramatic frequency dependence of these susceptibilities.

II. CHIRAL PARAMETERS

As mentioned in the Introduction, one expects the chiral interaction between molecules to involve parameters characterizing the chiral strengths of the molecules. However, there is no obvious precise quantitative formulation of parameters that characterizes the degree to which a given molecule is chiral. Only a handful of chiral strength parameters have been proposed. For instance, Osipov *et al.* (1994) developed a measure of molecular chirality by considering the symmetry of response functions describing the electromagnetic behavior of chiral molecules. We also introduced a chiral strength parameter in a previous calculation (Harris, Kamien, and Lubensky, 1997) of the chiral wave vector q_0 . We review this calculation of q_0 in Sec. IV. Both of the above chiral parameters are nonlocal (in a sense to be made more precise later), a feature that we shall see is generic. In the following we give a more systematic discussion of the structure of such chiral strength parameters.

A. Chirality is the absence of symmetry

A preliminary remark is that ‘‘chiral symmetry’’ is actually an absence of symmetry, i.e., the absence of symmetry under improper rotations. Thus a chiral object has lower symmetry than an achiral object that is invariant under chiral operations. This situation contrasts with ‘‘spherical symmetry,’’ which implies the existence, rather than the nonexistence, of symmetry elements. Accordingly, it is instructive to compare the way spherical symmetry is destroyed when a sphere is distorted to the way achiral symmetry is destroyed when an achiral object is chirally distorted. To start, we consider distortions of a sphere centered at the origin. Initially, the sphere of radius r_0 is a surface described by

$$r = r_0, \quad (2)$$

where r is the radial coordinate from the origin. When the sphere is distorted, the radial coordinate of its sur-

face will depend on the usual angles θ and ϕ and can be expanded in spherical harmonics:

$$r = r_0 + \sum_{n=1}^{\infty} \sum_{m=-n}^{m=n} a_{nm} Y_{nm}(\theta, \phi), \quad (3)$$

where $a_{nm} = a_{n,-m}^* (-1)^m$.

Usually one characterizes distortions by the values of the a_{nm} 's for the smallest value of n for which one of these is nonzero. The first-rank tensor a_{1m} describes translations of the sphere, which do not alter the symmetry and which we ignore. Thus the lowest-order distortions are characterized by a_{2m} , which in a Cartesian representation is a symmetric, traceless, second-rank tensor. In general, a complete specification of the shape of an aspherical surface requires the values of the infinite set of a_{nm} . Since the a_{nm} 's mix with each other under rotation, it is desirable to construct rotationally invariant measures of asphericity. A useful class is the quantities

$$\sigma_n \equiv \sum_m a_{nm}^2, \quad (4)$$

which provide rotationally invariant characterizations of the magnitude of the asphericity associated with n th-rank tensor distortions. It is entirely possible for σ_2 to vanish while higher-order σ_n do not. In this case the distortion is characterized by the lowest-order, nonvanishing value of σ_n .

With the above discussion in mind, we consider chirality. An object can be described by the multipole moments of its density, $\rho(r, \theta, \phi)$, namely

$$\tilde{\rho}_{lmN} \equiv \int d\mathbf{r} \rho(r, \theta, \phi) r^N Y_{lm}(\theta, \phi), \quad (5)$$

where $\tilde{\rho}_{lmN}^* = (-1)^m \tilde{\rho}_{l,-m,N}$ since $\rho(r, \theta, \phi)$ is real. The moments $\tilde{\rho}_{lmN}$ for a given N define a tensor parameter that transforms under a $(2l+1)$ -dimensional representation of the rotation group. The alternative Cartesian representation in terms of symmetric, traceless tensors $\tilde{\rho}_{lN}^{i_1 \dots i_l}$ of rank l is used extensively in treatments of liquid-crystalline order, and we shall employ them when appropriate. For a molecule consisting of point atoms, the density consists of a sum of Dirac delta functions locating each atom. This provides a natural framework to study interactions between molecules, in which connection the central quantities are $\tilde{\rho}_{lmN}$. The question we wish to address here is how these moments, or appropriate functions of them, characterize chirality. We start by discussing the analogs of the parameters σ_n in order to characterize the magnitude of chirality.

B. Construction of pseudoscalars

Bearing in mind that chirality requires the absence of inversion symmetry, we propose to characterize the magnitude of chirality by an infinite sequence of pseudoscalars. First, note that Lord Kelvin's definition may alternatively be stated as ‘‘an object is achiral if there exists a rotation Ω such that the object is invariant un-

der the operation $\Omega\mathbf{S}_2$, where \mathbf{S}_2 is spatial inversion.” Since spatial inversion is a mirror operation followed by a π rotation about an axis perpendicular to the plane of the mirror, this definition of chirality is equivalent to Lord Kelvin’s. A scalar is invariant under both rotations and inversion while a pseudoscalar is only invariant under rotations—it changes sign under inversion. Thus any pseudoscalar parameter ψ_n that we construct from the multipole moments of the density will necessarily vanish when the molecule is *achiral*. Furthermore, the degree of chirality can be characterized by the magnitudes of the set of ψ_n just as the degree of asphericity was characterized by the various σ_n .

The construction of pseudoscalars can be done systematically by considering the representation theory of the three-dimensional rotation group $O(3)$. This procedure amounts to nothing more than considering the quantum-mechanical addition of angular momentum. To each representation we will attach its transformation properties under inversion (i.e., parity). Pseudoscalars will transform as one-dimensional representations with odd parity. Denoting the d -dimensional representation with parity p as \mathbf{d}^p , we note that the rank- l representations generated by the multipole expansion are

$$\mathbf{1}^+, \mathbf{3}^-, \mathbf{5}^+, \dots, (\mathbf{2l+1})^{(-)^l}, \dots \quad (6)$$

To construct a pseudoscalar we must form tensor products of different representations. While the resulting representations obey the rules for addition of angular momentum, the parity of the new representation is simply the product of the parities of the two representations. For instance, since two spin-1 states (with odd parity) can be combined to form a spin-2, spin-1, or spin-0 state (all with even parity), we have

$$\mathbf{3}^- \otimes \mathbf{3}^- = \mathbf{5}^+ \oplus \mathbf{3}^+ \oplus \mathbf{1}^+. \quad (7)$$

This gives us our first representation that is not a multipole representation: $\mathbf{3}^+$, a *pseudovector*. Forming the triple tensor product,

$$\mathbf{3}^- \otimes \mathbf{3}^- \otimes \mathbf{3}^- = \mathbf{7}^- \oplus \mathbf{5}^- \oplus \mathbf{5}^- \oplus \mathbf{3}^- \oplus \mathbf{3}^- \oplus \mathbf{3}^- \oplus \mathbf{1}^-, \quad (8)$$

we arrive at our first pseudoscalar $\mathbf{1}^-$, which we recognize as the vector triple product $\mathbf{A} \cdot (\mathbf{B} \times \mathbf{C})$. The above discussion suggests that any pseudoscalar must involve a product of at least three of the multipole moments $\tilde{\rho}_{lmN}$. It is, in fact, always the case that a $\mathbf{1}^-$ can only be constructed from the tensor product of \mathbf{d}^+ and \mathbf{d}^- . Since the multipole moments do not include both \mathbf{d}^+ and \mathbf{d}^- , one must construct one of these via tensor products. Thus any pseudoscalar must involve a product of at least three of the multipole moments. This implies that a chiral parameter for a given object can be expressed as an integral over at least three position vectors in that object, and in this sense, chirality is a nonlocal property.

1. Nonpolar molecules

In this subsection we confine our attention to the case in which vector representations can be eliminated by proper choice of the center of the molecule. Specifically,

in this case we do not allow molecules to have a dipole moment. (That case will be considered in the next subsection.) To illustrate this theoretical discussion, let us look for the lowest-order (in powers of components of \mathbf{r}) pseudoscalar that can be constructed from the simple mass-weighted distance moments

$$\rho_{lm} = \sum_{\chi \in X} |\mathbf{r}_\chi|^l Y_{lm}(\theta_\chi, \phi_\chi) \quad (9)$$

of a homoatomic molecule, where the sum is over atoms χ in the molecule X . Throughout, we shall label molecules with capital Roman letters and their constituent atoms by Greek letters. The center of mass of molecule A will be \mathbf{R}_A , and each atom α will be displaced from there by $\mathbf{r}_{A\alpha}$. For simplicity we focus only on $\rho_{lm} \equiv \tilde{\rho}_{lm}$. Our discussion could be embellished by considering $\tilde{\rho}_{lmN}$ for other values of N . If we measure the density relative to the center of mass, then $\rho_{1m} = 0$ for all m . Thus the multipole expansion only provides us with $d = 5$ or larger-dimensional representations. Since we have restricted ourselves to a single tensor for each d -dimensional representation, $\mathbf{5}^+ \otimes \mathbf{5}^+$ will not contain any pseudotensors, and the lowest-order pseudotensor we can construct is contained in $\mathbf{5}^+ \otimes \mathbf{7}^-$. We could now try to construct a pseudoscalar by contracting the resulting tensors with $\mathbf{5}^+$, but, again because we are considering only the moments ρ_{lm} , we would get zero just as we would get zero for the triple product $\mathbf{A} \times \mathbf{B} \cdot \mathbf{A} = 0$ in the vector case. A nonzero pseudoscalar only results when $\mathbf{5}^+ \otimes \mathbf{7}^-$ is contracted with a tensor different from the $\mathbf{5}^+$ and the $\mathbf{7}^-$. Thus the lowest-order pseudoscalar we seek is in $\mathbf{5}^+ \otimes \mathbf{7}^- \otimes \mathbf{9}^+$. In terms of spherical harmonics we set

$$\psi_0 \propto \sum_{mn} C(234; mn) \rho_{2m} \rho_{3n} \rho_{4,m+n}^* \quad (10)$$

where $C(234; mn)$ are the appropriate Clebsch-Gordan coefficients. It is convenient to choose the normalization so that in the Cartesian representation this is

$$\psi_0 = \rho_2^{ij} \rho_3^{klm} \epsilon_{ikp} \rho_4^{jlm p} \quad (11)$$

Note the presence of the antisymmetric symbol ϵ_{ijk} in this expression. It is required to produce a scalar from two even-ranked and one odd-ranked tensor.

We can calculate ψ_0 for the “twisted H” molecule, M_1 , shown in Fig. 2, with four identical atoms at

$$M_1 = \{(a, b, c), (a, -b, -c), (-a, b, -c), (-a, -b, c)\}. \quad (12)$$

This molecule is chiral if $abc \neq 0$ and if $|a| \neq |b| \neq |c| \neq |a|$. Since ψ_0 is a rotational invariant, it may be evaluated in any convenient coordinate basis. We find

$$\psi_0 = K_0 (a^2 - b^2)(b^2 - c^2)(c^2 - a^2)abc, \quad (13)$$

where K_0 is a numerical constant. Note that ψ_0 does indeed vanish when the parameters assume the special values for which the molecule has the higher achiral symmetry. Moreover, since the mirror image of M_1 may be obtained by exchanging any two of a , b , and c or by reversing any one of their signs, we see that under inver-

sion $\psi_0 \rightarrow -\psi_0$, and it is indeed a pseudoscalar. This ninth-order multinomial is the lowest-order expression constructed from ρ_{lm} , which must vanish for an achiral object. However, just as in the discussion of asphericity, it is possible to consider a class of chiral molecules for which ψ_0 vanishes but which requires an even higher-order multinomial to characterize its chirality. Consider a 12-atom molecule, M_2 , obtained by taking the atoms as in the “twisted H” together with the eight atoms obtained by cyclic permutation, so that identical atoms are now at

$$M_2 = \{(a, b, c), (a, -b, -c), (-a, b, -c), (-a, -b, c), \\ (b, c, a), (-b, -c, a), (b, -c, -a), (-b, c, -a), \\ (c, a, b), (-c, a, -b), (-c, -a, b), (c, -a, -b)\}. \quad (14)$$

To show that ψ_0 vanishes for M_2 , it suffices to verify that $\rho_{2m} = 0$ for all m . (This result is most easily verified using the Cartesian representation for ρ_2^{ij} .) However, except for the special values of the parameters (i.e., $a = 0, b = 0, c = 0, |a| = |b|, |b| = |c|$, or $|c| = |a|$), this object is clearly still chiral since it is the union of three identical chiral objects. To describe its chirality the lowest-order pseudoscalar constructed from the moments ρ_{lm} is

$$\psi_1 = \sum_{\mu\nu} C(346; \mu\nu) \rho_{3\mu} \rho_{4\nu} \rho_{6,\mu+\nu}^*, \quad (15)$$

which we evaluate to be

$$\psi_1 = K_1 abc(a^2 - b^2)(b^2 - c^2)(c^2 - a^2) \\ \times (a^4 + b^4 + c^4 - 4a^2b^2 - 4b^2c^2 - 4c^2a^2), \quad (16)$$

where K_1 is a numerical constant. As was the case for ψ_0 , this chiral strength parameter vanishes when the “twisted H” is made to be achiral.

It is clear that we can construct an infinite sequence of chiral parameters from the ρ_{lm} that vanish for achiral objects. For example, when J, K , and L are all different integers whose sum is odd, each of the quantities

$$\psi_{JKL} = \sum_{mn} C(JKL; mn) \rho_{Jm} \rho_{Kn} \rho_{L,m+n}^* \quad (17)$$

is a chiral parameter, which is nonzero only for chiral molecules.

If we consider different tensors of a given rank, we can construct other sets of chiral parameters not encompassed by ψ_{JKL} . For example, if there are two distinct second-rank tensors γ_2^{ij} and τ_2^{ij} , then we can construct the chiral parameter

$$\psi_2 = \gamma_2^{il} \tau_2^{jm} \epsilon_{ijk} \rho_3^{klm} \propto \sum_{mn} C(223; mn) \gamma_{2m} \tau_{2n} \rho_{3,m+n}^*. \quad (18)$$

When $\gamma_2^{ij} = \tau_2^{ij}$, ψ_2 vanishes because ϵ_{ijk} is antisymmetric in all indices. The tensors γ_2^{ij} could, for example, be constructed from ρ_{2m} and $\tilde{\rho}_{2mN}$ for $N \neq l$. Alternatively, two different tensors could be constructed from the second-rank mass-moment tensor

$$\rho_2^{ij} = \sum_{\chi \in x} \left(r_\chi^i r_\chi^j - \frac{1}{3} r_\chi^2 \delta_{ij} \right). \quad (19)$$

To do this, we express ρ_2^{ij} in the basis of its orthonormal principal axes emblazoned on the molecule $\mathbf{e}_1, \mathbf{e}_2$, and \mathbf{e}_3 , where $\mathbf{e}_3 = \mathbf{e}_1 \times \mathbf{e}_2$ is associated with the largest-magnitude eigenvalue of ρ_2^{ij} . Then we decompose ρ_2^{ij} into its uniaxial (Q^{ij}) and biaxial (B^{ij}) components as

$$\rho_2^{ij} = SQ^{ij} + B(e_1^i e_1^j - e_2^i e_2^j) \equiv SQ^{ij} + B^{ij}, \quad (20)$$

where

$$S = \frac{3}{2} \sum_{\chi} \left[(\mathbf{r}_\chi \cdot \mathbf{e}_3)^2 - \frac{1}{3} r_\chi^2 \right], \quad (21a)$$

$$B = \frac{1}{2} \sum_{\chi} [(\mathbf{r}_\chi \cdot \mathbf{e}_1)^2 - (\mathbf{r}_\chi \cdot \mathbf{e}_2)^2], \quad (21b)$$

and

$$Q^{ij} = \left(e_3^i e_3^j - \frac{1}{3} \delta_{ij} \right). \quad (21c)$$

Note that B^{ij} , the biaxial part of ρ_2^{ij} , vanishes when the molecule is uniaxial. Setting $\gamma_2^{ij} = Q^{ij}$, $\tau_2^{ij} = B^{ij}$, and $\rho_3^{ijk} \equiv S^{ijk}$, we obtain

$$\psi_2 = Q^{il} B^{jm} \epsilon_{ijk} S^{klm} \quad (22)$$

as a chiral strength parameter, which plays a role in our calculation of the cholesteric pitch q_0 to be presented in Sec. IV. For the “twisted H” molecule, we have

$$\psi_2 = C_2 abc [|a^2 + c^2 - 2b^2| + a^2 - c^2] \quad \text{for } a^2 \leq b^2 \leq c^2, \quad (23)$$

where C_2 is a numerical constant. Expressions for ψ_2 in regimes other than $a^2 \leq b^2 \leq c^2$ can be obtained by suitably permuting variables. One may verify that when Eq. (23) is valid, ψ_2 vanishes when the molecule is achiral, i.e., when $a^2 = b^2 < c^2$ or $a^2 < b^2 = c^2$.

One can construct different second-rank tensors in other ways. For instance, in some phenomenological intermolecular potentials, the strength of the dispersion interaction between a pair of atoms is estimated to scale with the product of their atomic polarizabilities. In that case, a polarizability-weighted second-distance moment is generated by the multipole expansion of the intermolecular potential. In general, a tensor with any weighting that is distinct from the mass weighting can play the role of the additional second-rank tensor needed to characterize chirality. Such moments would have the form

$$\tilde{\rho}_{lm} = \sum_{\chi \in x} w_\chi Y_{lm}(\theta_\chi, \phi_\chi), \quad (24)$$

where w_χ is a weight factor, which can differ from the factor r_χ^l in Eq. (9). For a molecule with p atoms, we can obviously have up to p linearly independent second-rank tensors. As we mentioned, moments similar to these have been used in the study of optical properties of chiral systems by Osipov *et al.* (1995).

2. Ferroelectric liquid crystals

There are cases in which one may invoke the vector representation, even in liquid-crystalline systems. A par-

ticularly interesting case is that of ferroelectric liquid crystals (Meyer *et al.*, 1975). These phases are composed of mesogens that have an electric dipole moment. Recall that the smectic-*C* liquid-crystalline phase is a one-dimensional layered structure with layer normal \mathbf{N} . In each layer the nematic orientation \mathbf{n} is not parallel to \mathbf{N} . Thus one can construct the pseudovector $\mathbf{A} = (\mathbf{n} \cdot \mathbf{N})(\mathbf{n} \times \mathbf{N})$. It is clear that under parity \mathbf{A} does not change sign and that both the nematic ($\mathbf{n} \rightarrow -\mathbf{n}$) and layer normal ($\mathbf{N} \rightarrow -\mathbf{N}$) inversion symmetries are preserved. However, if the molecules are chiral, as we have seen, a nonvanishing pseudoscalar ψ may be constructed. In this case $\mathbf{P} = \psi \mathbf{A}$ is a true vector and can set an unambiguous alignment direction (perpendicular to \mathbf{n} and \mathbf{N}) for the molecular dipole moments.

In general, when electrostatic interactions are taken into account, both signs of charge are present and there is a nonzero dipole moment that no change of origin can eliminate. In this case, we can again construct two different second-rank tensors, τ_2^j and γ_2^j , and then

$$\psi_f = \sum_{mn} C(122; mn) \rho_{1m} \tau_{2n} \gamma_{2,m+n}^* \propto \rho_1^i \tau_2^{jk} \gamma_2^{lk} \epsilon_{ijl}, \quad (25)$$

is a pseudoscalar which includes the (dipole) charge moment ρ_{1m} ,

$$\rho_1^i = \sum_{\chi \in X} q_\chi r_\chi^i. \quad (26)$$

In fact one could construct a pseudoscalar from a vector triple product of three noncoplanar vectors obtained by introducing three different weight factors into the sum in Eq. (26).

III. "RUBBER GLOVE" MOLECULES

We have argued that a quantitative characterization of chirality does not rest on one parameter, but rather on an infinite hierarchy of chiral moments. However, one has a natural tendency to associate a specific handedness with a given chiral molecule. We shall show that even the "handedness" of a molecule depends on the chiral property under consideration. This is, in fact, familiar from circular dichroism measurements: the difference in attenuation of left versus right-circularly polarized light changes sign as a function of its wavelength. Thus the handedness of an object is really in the eye of the beholder.

To illustrate this idea, we consider a process in which a chiral molecule is continuously deformed into its enantiomer or mirror-image molecule. For the "twisted H" molecule, we could do this by continuously varying the parameter a until its final value becomes the negative of its initial value. Obviously, when a passes through zero the molecule is achiral and one might be tempted to say that the plane $a=0$ in parameter space separates regions of opposite handedness. However, as we shall show by example, it is possible to continuously deform a chiral molecule into its enantiomer without passing through an

TABLE I. Atoms and weightings W and W' for the chiral parameters ψ_0 and ψ'_0 of the "twisted H" molecule, M_1 .

Position (χ)	$W(\chi)$	$W'(\chi)$
(a, b, c)	1	$1 + \mu$
$(a, -b, -c)$	1	$1 + \mu$
$(-a, b, -c)$	1	$1 - \mu$
$(-a, -b, c)$	1	$1 - \mu$

achiral configuration. (Here "deformation" is used in its most general sense in which not only the coordinates, but also the mass and other properties of atoms are varied.) The existence of such a continuous deformation is incompatible with the existence of an intrinsic definition of right or left handedness. It is also clear that any single measure of chirality will pass through zero at some point in the process of deforming a molecule into its enantiomer. However, a molecule is achiral only if all of its chiral moments are zero; the vanishing of a single chiral moment alone does not make a molecule achiral. We shall illustrate explicitly that there exist paths of deformations between enantiomers along which there is no point where all chiral moments vanish. Nevertheless, along this path every chiral measure must and does vanish at some point. A molecule that can be deformed in this way is known as a topological rubber glove, in analogy with a real rubber glove—it can be inverted one finger at a time and thus always remains chiral (Walba *et al.*, 1995). In the context of our discussion we would interpret this by saying that the eye automatically measures many indices of chirality, and as each finger is inverted some indices may pass through zero to change sign until finally all indices have changed sign.

We can see this explicitly by keeping track of more than one chiral parameter as the "twisted H" is inverted continuously into its enantiomer. The two chiral parameters we shall monitor are ψ_0 and ψ'_0 . ψ_0 is defined in Eq. (10) and given explicitly in Eq. (13). ψ'_0 is also defined as in Eq. (10), except that now ρ_{lm} is replaced by $\rho_{lm}[W']$, where

$$\rho_{lm}[W] = \sum_{\chi \in X} W(\chi) |\mathbf{r}_\chi - \mathbf{r}^0[W]|^l Y_{lm}(\theta_\chi, \phi_\chi), \quad (27)$$

where $W(\chi)$ is a weighting function associated with the atom χ and $\mathbf{r}^0[W]$ is the W -weighted center of the molecule, chosen so that $\rho_{1m}[W]$ vanishes. Various weighting functions are shown in Table I. Until now we have considered molecules composed of identical atoms, i.e., $W(\chi) \equiv 1$. Of course, the molecule need not have identical atoms, and, therefore, not all properties of the atoms need be the same. For instance, if all the atoms are weighted equally, $\rho_{lm}[W]$ would correspond to a purely geometric moment. However, if we were to weight the atoms by their polarizabilities, then the moments would be different. We have defined ψ_0 to reflect geometric properties and ψ'_0 to reflect others. We could have instead introduced other weight functions that reflect the valence, electronegativities, etc., of the atoms. Since different properties are not perfectly correlated, they may require different weight functions. To construct the con-

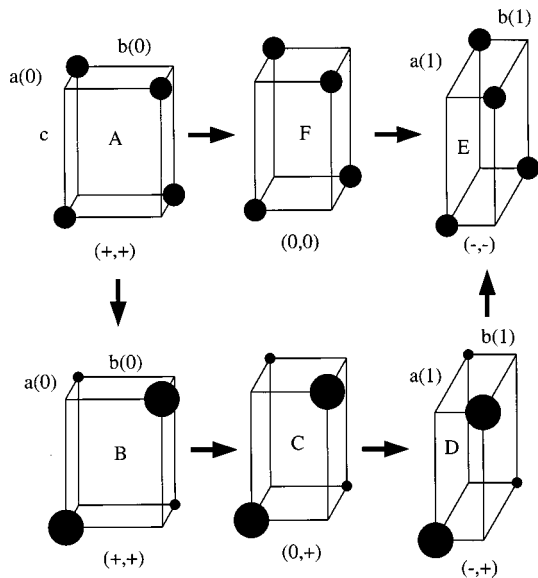

FIG. 6. Path I (AFE) and path II (ABCDE) between chiral enantiomers (mirror images) A and E for a molecule consisting of four atoms at the vertices of a twisted H for the parameters used in Fig. 7. Below each configuration we give (σ, σ') , where σ and σ' are, respectively, the signs or zero value of ψ_0 and ψ'_0 . In configurations C and F, $a=b$. Path AFE passes through the achiral configuration F. Path ABCDE passes through chiral configurations only. Configuration C would have a mirror plane (as does F) if the masses were all equal.

tinuous deformation between enantiomers, we only invoke “twisted H” molecules that have atoms with polarizabilities $1+\mu$ on sites 1 and 2 and $1-\mu$ on sites 3 and 4. The point here is that the molecule is chiral if either ψ_0 or ψ'_0 is nonzero.

In the calculation of ψ'_0 all displacements \mathbf{r}_χ are evaluated relative to the “center of polarizability” of the molecule, so that $\rho'_{1m}=0$ for all m . We find that

$$\psi'_0 = K_0(1-\mu^2)^2 abc(b^2-c^2) \times [(c^2-a^2)(a^2-b^2) - \frac{9}{7}\mu^2 a^4]. \quad (28)$$

When the molecule is tetrahedral ($a=b=c$), it is truly achiral if any two of its atoms are identical. Indeed in this case ψ_0 and ψ'_0 (as well as all other chiral parameters) vanish.

Let us now consider a process in which the molecule is distorted in the parameter space (a, b, μ) from the initial configuration A of Fig. 6 into its enantiomer, E, while remaining chiral along the entire path of deformation. Initially $\mu=0$ and $0 < a < b < c$.

Note that any pseudoscalar must change sign under reflection and therefore must pass through 0 somewhere along the path between enantiomers. We shall consider two paths between the molecule and its mirror image described in Fig. 6: the first will be a path AFE through an achiral point, the second a path ABCDE that goes only through chiral states, along which ψ_0 and ψ'_0 never simultaneously vanish. Our deformation will rearrange the molecule into its mirror image under the operation $(x, y, z) \rightarrow (y, x, z)$ which takes (a, b, c) into (b, a, c) . We may parametrize AFE by

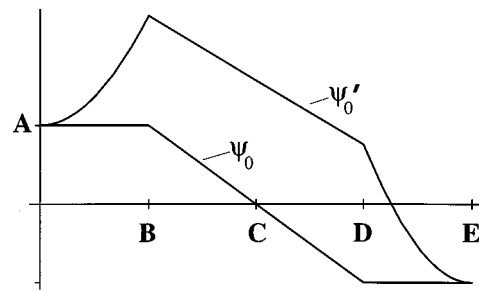

FIG. 7. Plot of the chiral measure ψ_0 and ψ'_0 along the path ABCDE. Note that both parameters pass through zero on this path, but they do not pass through zero at the same place. The parameters used to obtain this plot are $a(0)=0.99$, $b(0)=1.01$, $c=1.2$, and $\mu_0=0.15$.

$$a(t) = a(0) + [b(0) - a(0)]t, \quad (29a)$$

$$b(t) = b(0) + [a(0) - b(0)]t, \quad (29b)$$

$$\mu(t) = 0, \quad (29c)$$

where $t=0$ corresponds to the initial configuration A and $t=1$ to the enantiomer E. For concreteness, we have used the values $a(0)=0.99$, $b(0)=1.01$, and $c=1.2$. Note that $t=1/2$ corresponds to the point F, which is achiral, at which it is easy to see that $\psi_0 = \psi'_0 = 0$ since $a(1/2) = b(1/2)$ and $\mu=0$. To pass between enantiomers without passing through an achiral configuration we shall follow the path ABCDE along which the mass parameter μ does not remain fixed at zero. Note that this path avoids the line, $a=b$ and $\mu=0$, along which the molecule is achiral. Over the first section of the path, AB, we change the masses of the atoms by changing μ from its initial zero value to a suitable value μ ($\mu_0 = 0.15$). Over the second section, BCD, the mass parameter is held fixed, so that $\mu = \mu_0$, but a and b are varied as in Eqs. (29a),(29b), so at D $\mu = \mu_0$, $a(t_D) = b$, and $b(t_D) = a$. Finally along DE, $a(t)$ and $b(t)$ remain constant but μ is changed from μ_0 back to zero. For the parameter values we have chosen, ψ'_0 changes sign on this part of the path. Since configuration E is the mirror image of configuration A, the values of all chiral parameters, including ψ_0 and ψ'_0 have changed sign. But all states in the path of deformation are chiral and nowhere on this path do both ψ_0 and ψ'_0 simultaneously vanish. The chiral measures ψ_0 and ψ'_0 for the path ABCDE are plotted in Fig. 7.

We note that in a molecule with more than four atoms, our artificial deformation of the masses can be replaced by the additional degrees of freedom provided by the other atoms.

What shall we conclude from this example? Since we can continuously deform a molecule into its enantiomer via only chiral states, there is no general, unambiguous characterization of handedness.

IV. PREDICTION OF THE CHOLESTERIC PITCH

We now turn to the calculation of the cholesteric wave number q_0 in terms of the microscopic interactions be-

tween molecules. We shall argue that previous classical analyses of this problem have missed an essential feature of chiral interactions—the necessity of biaxial correlations between the molecules. Our result will involve the chiral parameter ψ_2 defined in Eq. (22). In accordance with experimental observations we shall assume that $q_0 a \ll 1$, where a is a typical intermolecular separation. This means that the cholesteric can be treated locally as a nematic even though it is twisting on longer length scales. Our aim, then, is to obtain a formula for q_0 in terms of correlation functions evaluated in the nematic limit, i.e., when all chiral interactions have been turned off. This type of result is particularly desirable for numerical simulations, since it only requires nematic correlation functions and hence simulations of the nematic state rather than the cholesteric state.

In this spirit we start by considering the long-wavelength properties of systems that are locally nematic with fluctuations described by the phenomenological Frank free energy (Frank, 1958), which depends on the director $\mathbf{n}(\mathbf{x})$. When surface terms are neglected, which only come into play when topological defects or internal surfaces are present (Kléman, 1983), the Frank free energy is

$$F = \frac{1}{2} \int d^3x \{ K_1 (\nabla \cdot \mathbf{n})^2 + K_2 (\mathbf{n} \cdot \nabla \times \mathbf{n})^2 + K_3 [\mathbf{n} \times (\nabla \times \mathbf{n})]^2 + 2h \mathbf{n} \cdot \nabla \times \mathbf{n} \}. \quad (30)$$

This effective free energy can describe most of the phenomena of nematic and cholesteric liquid crystals. The parameter h is the generalized thermodynamic force that determines the pitch. We shall refer to h as the torque field since it is proportional to the microscopic intermolecular torques as we shall show. To see how h determines the pitch, we consider a helical configuration of $\mathbf{n}(\mathbf{x})$ as in Eq. (1). Then, the twist

$$-\mathbf{n} \cdot \nabla \times \mathbf{n} = q \quad (31)$$

is spatially uniform, $\nabla \cdot \mathbf{n} = 0$, and $\mathbf{n} \times (\nabla \times \mathbf{n}) = 0$. The Frank free energy is

$$F = Y \left\{ \frac{1}{2} K_2 q^2 - h q \right\}, \quad (32)$$

where Y is the volume of the system. This energy is minimized when

$$q = q_0 = h/K_2. \quad (33)$$

Note that h is a pseudoscalar. Under spatial inversion, h and therefore also the “twist” change sign: $\mathbf{n} \cdot \nabla \times \mathbf{n} \rightarrow -\mathbf{n} \cdot \nabla \times \mathbf{n}$ since it is linear in spatial gradients. To obtain a nonzero value of h it is, therefore, necessary that the system not be invariant under spatial inversion. Furthermore, we see that to evaluate q_0 we need to calculate both h and K_2 .

The Frank elastic constants K_1 , K_2 , and K_3 can be estimated by dimensional analysis using only excluded volume (entropic) interactions by dividing an energy scale by a length scale. Taking the energy scale to be $k_B T \sim 4 \times 10^{-14}$ erg and the length scale to be a molecu-

lar size ~ 1 nm, we find that $K_i \sim 4 \times 10^{-7}$ dyne, or about 1μ dyne. This is approximately correct for typical liquid crystals that exist at room temperature. As we discussed in the Introduction, dimensional analysis does not predict q_0 correctly: q_0^{-1} is typically on the order of or larger than hundreds of nanometers and does not correspond to any natural length scale in the problem. The challenge, therefore, is to calculate h and to determine why its magnitude does not correspond to what dimensional analysis suggests.

A major objective is to establish an approach that in principle will provide a rigorous calculation of the cholesteric pitch (or equivalently of h) in the limit when the pitch is very long, i.e., when $q_0 a \rightarrow 0$. The starting point of any microscopic calculation of h must be the intermolecular potentials. Liquid-crystal mesogens are notoriously complex, containing hundreds to hundreds of thousands of individual atoms, and they have correspondingly complex interactions. A reasonable approach, and the one we pursue here, for constructing the desired potentials is to model each mesogen as a collection of connected spherically symmetric atoms that interact via pairwise central-force potentials with atoms on other mesogens. The interatomic potential consists of a long-range van der Waals part and a short-range repulsive part arising mostly from the Pauli exclusion principle. Fluid physics is dominated by the short-range repulsive part, and it is often useful to replace the full interatomic potential by a simple hard-core potential with no attractive part. An intermolecular potential constructed in this way includes steric interactions that force two chiral objects like screws or ridged “barber poles” (Fig. 5) to twist relative to each other when in contact.

There are contributions to the effective intermolecular potential that cannot be expressed as a superposition of interatomic central-force potentials. The simplest such contribution is a chiral dispersion potential—an anisotropic generalization of the van der Waals potential. Dispersion forces arise from the Coulomb potential between all pairs of electronic and nuclear charges and quantum fluctuations of the electronic states. The van der Waals potential is produced by the interaction of fluctuating electric dipoles on different atoms. If molecules are chiral, a fluctuating dipole on one molecule can interact with a fluctuating quadrupole on another to produce an effective chiral dispersion force (van der Meer *et al.*, 1976; Kats, 1978; Issaenko *et al.*, 1999). It is difficult at the moment to obtain first-principles estimates of the strength of chiral dispersion forces.

In what follows, we confine our attention to pairwise central-force interactions. Once the intermolecular potentials have been chosen, the next step is to devise a scheme to compute h . Since $q_0 a \ll 1$, one may assume that h is small and calculate all quantities to lowest order in h , or equivalently to lowest order in $q_0 a$. The cholesteric twist induces biaxial contributions to the nematic order parameter or order $(q_0 a)^2$ (Priest and Lubensky, 1974). Thus, to lowest order in $q_0 a$, biaxiality can be ignored, and the cholesteric can be treated as though it were locally uniaxial. Mean-field theory is a natural first

calculational approach to pursue (Schröder, 1979; Evans, 1992; Pelcovits, 1996; Ferrarini *et al.*, 1996). In the locally uniaxial limit appropriate to most cholesteric, mean-field theory will always predict $h=0$ (Salem *et al.*, 1987) when central-force potentials between atoms are assumed. This result is easy to understand: Mean-field calculations seek the best self-consistently determined distribution function for a single mesogen. In a uniaxial system, this distribution function will be uniaxial and produce only uniaxial average mass moments. Since there are no uniaxial structures that are chiral, any manifestation of chirality is washed out, there will be no potential favoring relative twist of neighboring molecules, and q_0 will be zero. Thus a more powerful approach than mean-field theory is needed to calculate q_0 in the majority of cholesterics that are nearly uniaxial. In the less common case that would arise when chirality is introduced in a biaxial nematic, the cholesteric is locally biaxial, and mean-field theory will produce a nonvanishing value of q_0 .

The failure of mean-field theory can be traced to its neglect of biaxial correlations between neighboring molecules. A first-principles theory developed by the authors (Harris *et al.*, 1997) provides a rigorous method, not limited to mean-field theory, for calculating h . Its principal result is that, under certain approximations, h is proportional to a measure ψ of molecular chirality times the spatial integral of a biaxial correlation function—a function that is strictly zero in mean-field theory. Thus h is small and deviates from expectations based on dimensional analysis both because ψ can be small and because biaxial correlations may be very short ranged. Here we outline some important features of this theory. It begins with a rigorous expression of h , which can be obtained from Eq. (32):

$$h = - \frac{1}{Y} \left. \frac{\partial F}{\partial q} \right|_{q=0}. \quad (34)$$

In the Appendix we show that within certain simplifying conditions this formulation leads to the result for the cholesteric wave vector,

$$q_0 = - \frac{1}{4K_2Y} \left\langle \sum_{BA} \mathbf{R}_\perp \cdot \boldsymbol{\tau}_{BA} \right\rangle, \quad (35)$$

where $\boldsymbol{\tau}_{BA}$ is the torque exerted on molecule B by molecule A :

$$\tau_{BA}^i = \sum_{\beta\alpha} \epsilon_{ijk} r_{B\beta}^j \partial_k V(\mathbf{R} + \mathbf{r}_{B\beta} - \mathbf{r}_{A\alpha}), \quad (36)$$

and $\langle \cdot \rangle$ denotes thermodynamic averaging. It is no surprise that the intermolecular torques are the origin of the cholesteric structure. Indeed, if we had considered two planes of molecules a distance L apart along an axis perpendicular to the nematic director, then the change in angle between them would be $\theta=qL$ and thus the expression for h in Eq. (34) would become

$$h = - \frac{L}{Y} \left. \frac{\partial F}{\partial \theta} \right|_{\theta=0}, \quad (37)$$

which is simply the torque per unit area. Moreover, Eq. (35) provides a rigorous small- q_0 expression for q_0 in a fully aligned nematic in terms of quantities to be evaluated in the nematic limit, i.e., when molecular chirality is turned off. It is interesting to observe that this result does not involve simply the torque $\boldsymbol{\tau}_A \equiv \sum_B \boldsymbol{\tau}_{BA}$ on molecule A . In the nematic phase the average torque on molecules in the interior of the sample is zero. Whether or not the nematic is locally unstable relative to states with nonzero q depends on the boundary conditions (Harris *et al.*, 1999). Accordingly, Eq. (35) involves what we call the “projected torque on molecule A ,” namely $\sum_B \mathbf{R}_\perp \cdot \boldsymbol{\tau}_{BA}$. Finally, the appearance of the antisymmetric tensor in Eq. (36) guarantees that q_0 is a pseudoscalar and hence must vanish for a system in which all molecules are achiral.

We now discuss some of the implications of the result in Eq. (35). For this purpose we consider a number of approximations that lead to a simple, yet nontrivial case. First, the molecules are assumed to have their long axes perfectly aligned along the director, i.e., their principal axes vectors \mathbf{e}_3 are parallel to \mathbf{n} . Although strictly speaking this limit is not realized in real systems, it does enable us to see some simple consequences of our formalism. Second, we neglect correlations between density fluctuations and orientational fluctuations. Finally, we invoke an expansion in powers of r/R . Elsewhere (Harris *et al.*, 1999) we give a less restrictive discussion. As our prior discussion indicates, we must be sure to take the uniaxial average of the molecular orientations. In doing so, we found (Harris *et al.*, 1997) that the first non-zero term upon averaging was fifth order in powers of r . The lowest order expression for q_0 depends on the nematic alignment tensor Q^{ij} , the biaxial tensor B^{ij} , and the third-rank tensor S^{ijk} introduced in Eq. (21). We found

$$q_0 = - \frac{\sum_{BA} \epsilon_{ijk} Q^{ip} \langle (B_B^{jl} S_A^{kpl} + B_A^{jl} S_B^{kpl}) K(\mathbf{R}) \rangle}{8K_2Y}, \quad (38)$$

where $K(\mathbf{R})$ is a sum of products of $|\mathbf{R}|$ and derivatives of the interaction potential $V(\mathbf{R})$.

The sum in Eq. (38) is averaged over molecular orientations and locations. The tensors B^{ij} and S^{ijk} depend on the orientation of the molecule. In fact, if the molecules spin independently about their long axes, this average of B_X^{ij} will vanish. Moreover, the components of S_X^{ijk} that contribute to Eq. (38), \bar{S}^{ijk} , can be expressed in terms of B_X^{ij} so that, for identical molecules, Eq. (38) becomes

$$q_0 = - \psi_2 \frac{\sum_{BA} \langle (B_B^{ij} B_A^{ij}) K(\mathbf{R}) \rangle}{8K_2Y \text{Tr}(B^2)}, \quad (39)$$

where $\psi_2 \equiv S^{klm} \epsilon_{ijk} Q^{il} B^{jm}$, as defined in Sec. II, is evaluated on a *single molecule*. Hence ψ_2 is a pseudoscalar parameter that is a measure of the chiral interaction between identical chiral molecules. It vanishes when the molecules are not chiral, and it provides a quantitative index of chirality as would be measured through the cholesteric pitch. We emphasize, however, that other microscopic measures of chirality will in gen-

eral involve other chiral parameters. Note that, since the biaxial correlations can be negative at the intermolecular separation, there is not even a correlation between the signs of ψ_2 and the cholesteric pitch.

The correlation function in Eq. (39) may be evaluated in the decoupling approximation where the molecular separation \mathbf{R} is uncorrelated with the biaxial orientation. In this case the biaxial correlation function is simply the average

$$\langle (B_B^{ij} B_A^{ij}) \rangle = \langle \cos[2(\phi_A - \phi_B)] \rangle, \quad (40)$$

where [see Fig. 1(c)] ϕ_A is the angle between the biaxial axis of molecule A and the x axis.

In the above calculation of q_0 , we assumed that all molecules in the cholesteric were chiral. In order for a chiral interaction producing relative twist between two molecules to exist, however, it is only necessary for one molecule to be chiral. The linearity of our expression for q_0 [Eq. (39)] in ψ_2 is a consequence of this fact. If both molecules had to be chiral, one might expect q_0 to be proportional to ψ_2^2 . This is impossible, of course, because a pseudoscalar (q_0) cannot be proportional to the square of a pseudoscalar (ψ_2). The expression for q_0 for a system composed of a mixture of chiral and achiral molecules is essentially the same as Eq. (39) except that A and B refer to different molecular species and ψ_2 is the chiral parameter of the chiral molecule. There are also chiral interactions between a chiral molecule and a strictly uniaxial molecule. These interactions lead to contributions to q_0 that depend on correlations between the chiral parameter of the chiral molecule and the biaxial anisotropy of the positional correlation of its uniaxial neighbor. Thus, when a nematic is doped with chiral molecules, a finite pitch must result, and we expect q_0 to be proportional to the dopant concentration when it is small.

V. DISCUSSION AND CONCLUSION

In this colloquium we considered ways of characterizing and quantifying molecular chirality and of calculating the pitch wave number q_0 , a macroscopic manifestation of chirality in cholesteric liquid crystals. We showed that there is not one, but an infinite number of chiral parameters that characterize a chiral object. Each chiral parameter is a pseudoscalar, whose construction, if it is obtained from mass or charge distributions, requires the contraction of at least three mass- or charge-moment tensors. Chiral parameters for a given object can have varying magnitudes and even different signs. It is possible to pass continuously from a chiral object to its mirror image without ever passing through a state in which the object is achiral. In this process, each chiral parameter passes through zero, but at no point do all parameters pass simultaneously through zero. We showed in Sec. IV that the macroscopic pitch depends on both molecular chiral parameters and on molecular orientational correlations. Since these correlations vary with temperature, pH , pressure, etc., it is possible to change the magnitude of the cholesteric pitch without

changing molecules. This mechanism may be the explanation for the phenomena of twist inversion (Stegemeyer *et al.*, 1989) in which the pitch changes continuously from right- to left-handed as a function of temperature. Moreover, orientational order (e.g., hexatic) can selectively enhance different intermolecular correlations and thus change the importance of different chiral parameters for determining the macroscopic cholesteric pitch.

Finally, we emphasize the usefulness of the formal development of Sec. IV. It represents an important advance in that, in the limit of long pitch, it gives an expression for the pitch in terms of quantities in the nematic system when chiral interactions have been turned off. Especially for simulations, this implies that it is not necessary to simulate a long-pitch system. Instead one can simulate a homogeneous nematic in order to get correlation functions of the type appearing in Eq. (33). Further analysis in this direction may be needed to actually implement this idea.

ACKNOWLEDGMENTS

It is a pleasure to acknowledge stimulating discussions with Joel Schnur and David Walba. A.B.H. was supported by NSF Grant No. DMR95-20175. R.D.K. was supported through NSF Grant No. DMR97-32963, the Research Corporation, and L. J. Bernstein. T.C.L. was supported by NSF Grant No. DMR97-30405.

APPENDIX: EXPRESSION FOR THE TORQUE FIELD

In this appendix we recast the expression for h in a simplifying limit, viz. when the molecules are perfectly aligned along the local nematic axis (but their biaxial axis is not fixed). We start from Eq. (34). As mentioned in the text, it is clear that h is zero if the system is achiral. Thus we are interested in the terms in the free energy that are linear in the chiral parameters, ψ_n . So we may write

$$h = -\frac{1}{Y} \sum_n \psi_n \left. \frac{\partial^2 F}{\partial q \partial \psi_n} \right|_{q=0, \psi_n=0}. \quad (A1)$$

Note that q enters the calculation in the following way. We consider a helical phase in which the director \mathbf{n} is given by Eq. (1). In the small- q limit, the atomic coordinates are displaced by an amount $\delta r_{A\alpha}^i$ from their reference positions in the nematic phase, where $\delta r_{A\alpha}^i = \epsilon^{ijk} \delta \omega_A^j r_{A\alpha}^k$, $\delta \omega_A^j = q e^j (\mathbf{e} \cdot \mathbf{R}_A)$ and where \mathbf{e} is an arbitrary unit vector perpendicular to \mathbf{n} . In this sense the total potential energy U has a q dependence, such that

$$\frac{\partial U}{\partial q} = \sum_{A\alpha i} \frac{\partial U}{\partial r_{A\alpha}^i} \frac{\partial r_{A\alpha}^i}{\partial q}. \quad (A2)$$

With this understanding, one evaluates Eq. (A1) as

$$h = -\frac{1}{Y} \sum_n \psi_n \left[\left\langle \frac{\partial^2 U}{\partial q \partial \psi_n} \right\rangle + \chi_n \right], \quad (A3)$$

where $\langle \cdot \rangle$ denotes a thermodynamic average in which the density matrix $\exp[-U/(k_B T)]$ is evaluated when all molecular chirality is turned off and

$$\chi_n = \frac{1}{k_B T} \left\langle \frac{\partial U}{\partial q} \frac{\partial U}{\partial \psi_n} \right\rangle. \quad (\text{A4})$$

Note the appearance in h of the terms in χ_n . As we show elsewhere (Harris *et al.*, 1999), these terms, which normally are not considered, are needed to obtain the expected result that h vanishes in the limit of an isotropic fluid (for which the nematic order parameter vanishes). However, in the limit of nearly complete nematic order (which we consider here), these terms in χ_n are negligible. Superficially it may appear that we have to isolate the dependence of U on the chiral parameters. However, since achiral components of U do not contribute to $\langle \partial U / \partial q \rangle$, this step is, in fact, not necessary, so that

$$h = - \frac{1}{Y} \left\langle \frac{\partial U}{\partial q} \right\rangle. \quad (\text{A5})$$

This equality is the basis of our calculation—it allows us to calculate $\partial F / \partial q$ *microscopically* in terms of molecular interactions. In particular, note that the result is expressed in terms of a correlation function to be evaluated in the nematic ($q=0$) limit (which we do implicitly in the following). It is important to note that in the more realistic limit when the orientations of the molecules fluctuate away from the local nematic direction, both terms in Eq. (A3) must be retained. Such a calculation has not yet been carried out.

Writing the potential energy as a sum of identical (for simplicity), pairwise central-force interactions $V(\mathbf{R})$ and using Eqs. (33), (A2), and (A5), we find

$$q_0 = - \frac{1}{2K_2 Y} \left\langle \sum_{BA\beta\alpha} \epsilon_{ijl} \partial_i V(\mathbf{R}_B + \mathbf{r}_{B\beta} - \mathbf{R}_A - \mathbf{r}_{A\alpha}) \times e_j \{ (\mathbf{e} \cdot \mathbf{R}_B) r_{B\beta}^k - (\mathbf{e} \cdot \mathbf{R}_A) r_{A\alpha}^k \} \right\rangle. \quad (\text{A6})$$

Because the system is uniaxial, we can average over all perpendicular directions \mathbf{e} , so that $e_i e_j \rightarrow \frac{1}{2}(\delta_{ij} - n_i n_j)$. In this case Eq. (A6) becomes

$$q_0 = - \frac{1}{4K_2 Y} \left\langle \sum_{BA\beta\alpha} \epsilon_{ijk} \partial_i V(\mathbf{R} + \mathbf{r}_{B\beta} - \mathbf{r}_{A\alpha}) \times [R_{\perp}^j r_{B\beta}^k + R_{\perp}^j (r_{B\beta}^k - r_{A\alpha}^k)] \right\rangle, \quad (\text{A7})$$

where \mathbf{R}_{\perp} is the projection of \mathbf{R} onto the plane perpendicular to \mathbf{n} and $\mathbf{R} \equiv \mathbf{R}_B - \mathbf{R}_A$. By translational invariance, the second of the two terms inside the square brackets of Eq. (A7) must vanish: for fixed molecule B , one can shift the origin of the coordinate system by a fixed vector $\mathbf{\Delta}$. This would make the second term depend on the choice of origin, which it cannot. Hence we find that

$$q_0 = - \frac{1}{4K_2 Y} \left\langle \sum_{BA} \mathbf{R}_{\perp} \cdot \boldsymbol{\tau}_{BA} \right\rangle, \quad (\text{A8})$$

where $\boldsymbol{\tau}_{BA}$ is the torque exerted on molecule B by molecule A :

$$\boldsymbol{\tau}_{BA}^i = \sum_{\beta\alpha} \epsilon_{ijk} r_{B\beta}^j \partial_k V(\mathbf{R} + \mathbf{r}_{B\beta} - \mathbf{r}_{A\alpha}). \quad (\text{A9})$$

GLOSSARY

For the nonspecialist, we include the following glossary of technical terms.

cholesteric: a material in the cholesteric (or twisted nematic) phase. The director in this phase has a helical structure (depicted in Fig. 3) obtained by twisting a nematic.

director: unit vector \mathbf{n} specifying the direction of average orientation of anisotropic molecules in a mesophase.

enantiomer: a molecule with a given chemical formula can exhibit many different geometrical structures called isomers. A chiral isomer is an enantiomer. A chiral isomer and its mirror image are an enantiomeric pair.

Frank free energy: energy [Eq. (30)] associated with long-wavelength distortions of the director in a nematic. It is proportional to the square of spatial derivatives of \mathbf{n} .

mesogen: a molecule that forms a mesophase.

mesophase: a phase with symmetry intermediate between that of the most disordered isotropic, spatially homogeneous fluid phase and those of the most ordered periodic crystal phases. All liquid-crystal phases except for those, such as the cholesteric blue phase, that have true three-dimensional periodic order are mesophases.

nematic: a liquid-crystalline material composed of anisotropic (rod or disk shaped) particles with long-range orientational but no long-range translational order. This term comes from the Greek word *νεμα* for thread. A nematic is often filled with defects that look like threads under cross polarizers.

nematogen: a molecule that forms a nematic phase.

smectic: from the Greek word *σμεγμα* for soap. A smectic phase is a “solid” in one dimension and a fluid in the other two directions. It consists of equally spaced parallel layers.

steric: arising from hard-core, excluded-volume interactions. This term comes from the Greek word *στερεος* for solid.

REFERENCES

- de Gennes, P.-G., and J. Prost, 1993, *The Physics of Liquid Crystals*, 2nd ed. (Oxford University Press, Oxford, New York).
- Evans, G. T., 1992, *Mol. Phys.* **77**, 969.
- Ferrarini, A., G. J. Moro, and P. L. Nordio, 1996a, *Mol. Phys.* **87**, 485.

- Ferrarini, A., G. J. Moro, and P. L. Nordio, 1996b, *Phys. Rev. E* **53**, 681.
- Fraden, S., 1995, in *Observation, Prediction, and Simulation of Phase Transitions in Complex Fluids*, edited by M. Baus, L. F. Rull, and J. P. Ryckaert (Kluwer, Dordrecht).
- Frank, F. C., 1958, *Discuss. Faraday Soc.* **25**, 19.
- Harris, A. B., R. D. Kamien, and T. C. Lubensky, 1997, *Phys. Rev. Lett.* **78**, 1476; 2867(E).
- Harris, A. B., R. D. Kamien, and T. C. Lubensky, 1999 (unpublished).
- Issaenko, S. A., A. B. Harris, and T. C. Lubensky, 1999, *Phys. Rev. E* **60**, 578.
- Kats, E. I., 1978, *Eksp. Teor. Fiz.* **74**, 2320 [*Sov. Phys. JETP* **47**, 1205 (1978)].
- Kléman, M., 1983, *Points, Lines, and Walls: in Liquid Crystals, Magnetic Systems, and Various Ordered Media* (Wiley, New York).
- Landau, L. D., and E. M. Lifshitz, 1977, *Quantum Mechanics*, 3rd ed. (Pergamon, Oxford).
- Meyer, R. B., L. Liebert, L. Strzelecki, and P. Keller, 1975, *J. Phys. (France) Lett.* **36**, L-69.
- McMurry, J., 1992, *Organic Chemistry* (Brooks/Cole, Pacific Grove, CA), p. 295.
- Osipov, M. A., B. T. Pickup, and D. A. Dunmur, 1995, *Mol. Phys.* **84**, 1193.
- Pasteur, L., 1848, *Ann. Chim. Phys.* **24**, 442.
- Pelcovits, R. A., 1996, *Liq. Cryst.* **21**, 361.
- Priest, R., and T. C. Lubensky, 1974, *Phys. Rev. A* **9**, 99.
- Reinitzer, F., 1888, *Monatsch. Chem.* **9**, 421.
- Salem, L., X. Chapuisat, G. Segal, P. Hiberty, C. Minot, C. Leforestier, and P. Sautet, 1987, *J. Am. Chem. Soc.* **109**, 2887.
- Schröder, H., 1979, *The Molecular Physics of Liquid Crystals*, edited by G. R. Luckhurst and G. W. Gray (Academic, New York), Chap. 5.
- Stegemeyer, H., K. Siemsmeyer, W. Sucrow, and L. Appel, 1989, *Z. Naturforsch., A: Phys. Sci.* **44**, 1227.
- Straley, J. P., 1976, *Phys. Rev. A* **14**, 1835.
- Stroobants, A., H. N. W. Lekkerkerker, and D. Frenkel, 1986, *Phys. Rev. Lett.* **57**, 1452.
- Thomson, W., 1904, *The Robert Boyle Lecture, Oxford University Junior Scientific Club, May 16, 1893*, reprinted in *Baltimore Lectures* (C. J. Clay & Sons, London).
- Van der Meer, B. W., G. Vertogen, A. J. Dekker, and J. G. J. Ypma, 1976, *J. Chem. Phys.* **65**, 3935, and references therein.
- Walba, D. M., T. C. Horman, R. M. Richards, and R. C. Haltiwanger, 1995, in *Knots and Applications*, edited by L. H. Kauffman (World Scientific, Singapore).