

# Single- and double-slit diffraction of neutrons

Anton Zeilinger

*Atominstytut der Österreichischen Universitäten, A-1020 Wien, Austria*

Roland Gähler

*Reaktorstation der Technischen Universität, D-8046 Garching, Federal Republic of Germany*

C. G. Shull

*Massachusetts Institute of Technology, Cambridge, Massachusetts 02139*

Wolfgang Treimer

*Hahn-Meitner-Institut für Kernforschung, D-1000 Berlin 39, Federal Republic of Germany*

Walter Mampe

*Institut Max von Laue-Paul Langevin, F-38042 Grenoble, France*

The authors report detailed experiments and comparison with first-principle theoretical calculation of the diffraction of cold neutrons ( $\lambda \approx 2$  nm) at single- and double-slit assemblies of dimensions in the 20–100  $\mu\text{m}$  range. Their experimental results show all predicted features of the diffraction patterns in great detail. Particularly, their double-slit diffraction experiment is its most precise realization hitherto for matter waves.

## CONTENTS

I. Introduction	1067
II. Experimental Setup and Procedure	1068
III. Numerical Calculations	1069
IV. Single-Slit Results	1070
V. Double-Slit Results	1072
Acknowledgments	1073
References	1073

## I. INTRODUCTION

Today, more than 60 years after the epochal proposal by Louis de Broglie of wave properties of matter, experimental evidence for these properties is convincing beyond doubt. Besides the classical experiments of the diffraction of electrons and neutrons at crystal lattices, numerous other diffraction experiments, including some with other elementary particles and even with atoms, have been performed. Particle diffraction has therefore evolved to one of the most powerful experimental tools for the exploration of the submicroscopic domain.

In view both of the immense importance of wave mechanics and of the considerable epistemological problems posed by the question of its proper interpretation (see, e.g., Feynman *et al.*, 1965), it is of fundamental importance and of considerable pedagogic significance to study experimentally the diffraction of particles at simple macroscopic objects whose properties can be established by independent observation. In that class of experiments, one can distinguish work that aims at demonstrating the existence of the expected diffraction pattern and its qualitatively relevant features from those experiments that aim at explicitly comparing observation with theory at a detailed quantitative level. Surprisingly, the number of

existing experiments belonging to the latter category is very small to date as opposed to the case of the diffraction of light at macroscopic objects where the agreement between theory and experiments has been established in great detail (see, e.g., Rinard, 1976, and references therein).

For electrons, experiments studying the diffraction at single-, double-, and multiple-slit assemblies have been reported by Möllenstedt and Jönsson (1959) and by Jönsson (1961, 1974). The diffraction patterns obtained in these electron experiments have been compared only in a semiquantitative way with theoretical prediction. This is caused partly by the use of the Fraunhofer limit in the theory and partly, we suggest, by the necessity of employing in the experiment electron microscopic enlargement of the diffraction patterns, which implies the problems associated with the imaging aberrations of electron optical systems. Consequently, Jönsson observed some differences between theory and experiment that he expects will be eliminated if a more sophisticated attempt were to be made at data evaluation. We also note that in these experiments only the positions of the diffraction maxima were compared with theory and not the details of the intensity distributions.

For neutrons, Shull (1969) has studied the diffraction of  $\lambda = 4.43$  Å neutrons at single slits of varying width. For the angular diffraction spreading of the central zero-order maximum, he found good agreement with theory. Kurz and Rauch (1969) and Graf, Rauch, and Stern (1979) reported the diffraction of cold neutrons at gratings. Again, they observed good agreement with theory on a semiquantitative level; some discrepancies observed in the details of the intensity distributions are, they

suspect, caused by imperfections of the diffraction gratings. The observation by Scheckenhofer and Steyerl (1977) of the diffraction of ultracold neutrons at reflection gratings did demonstrate general agreement with the theoretical prediction, but there the intensities were too low to permit a detailed quantitative comparison. Analogously, in the experiments on the Fresnel diffraction of cold neutrons at zone plates (Kearney, Klein, Opat, and Gähler, 1980; Klein, Kearney, Opat, and Gähler, 1981) and in the measurements of the intensity distributions emerging from a Fresnel biprism interferometer (Maier-Leibnitz and Springer, 1962) or from a Billet-type split-lens interferometer (Klein, Kearney, Opat, Cimmino, and Gähler, 1981), no detailed comparison of theory and experiment was performed.

It is the purpose of the present paper to report a series of experiments of the diffraction of cold neutrons at single- and double-slit assemblies measured with high statistical accuracy and a detailed first-principles comparison with theoretical prediction.

## II. EXPERIMENTAL SETUP AND PROCEDURE

The experiments were performed on the neutron optical bench initially used by Maier-Leibnitz and Springer (1962) for biprism interferometer studies. This optical bench has been set up at the very-cold-neutron beam *H18* of the high-flux reactor at the Institut Laue-Langevin in Grenoble for studies of the electric neutrality of the neutron (Gähler, Kalus, and Mampe, 1982; Baumann, Kalus, Gähler, Mampe, and Alefeld, 1988) and has been used for a variety of neutron optical experiments (Klein and Zeilinger, 1984) including the diffraction at a straight absorbing edge (Gähler, Klein, and Zeilinger, 1981).

Neutrons from the cold source of the high-flux reactor were guided by a bent neutron guide to a monochromator system that used the dispersive properties of prism refraction (Fig. 1). The slits  $S_1$  and  $S_2$  defined the neutron beam incident on the prism, and the much smaller optical bench entrance slit  $S_3$  selected the neutrons out of the

rainbow radiation field refracted by the prism. The width of the wavelength band used in the experiment was then a function of all three slits together while the angular width of the radiation was mainly a function of  $S_2$  and  $S_3$  alone. Slit  $S_3$  also defined through slit diffraction the width of the coherent wave front in the object plane, which was located after a flight path of 5 m. After another 5 m of flight path the scanning exit slit  $S_4$  measured the intensity distribution in the image plane. The neutrons were finally counted in a  $BF_3$  detector, which was heavily shielded against background radiation. The beam paths along the optical bench were evacuated in order to minimize absorption and scattering. All the critical components, i.e., the entrance slit  $S_3$ , the scanning slit  $S_4$ , and the diffracting object, were supported directly from the optical bench. This optical bench was a thermally isolated steel beam of 10.5 m length that had been annealed in order to relieve internal strains. The steel beam was hollow and had been filled with water to increase its thermal inertia and to minimize internal temperature gradients. It was found in our experiments that it was not necessary to provide active temperature stabilization.

The wavelength of the neutrons could be varied between about 15 and 30 Å by rotating the monochromating prism around its vertical axis and/or by repositioning the slit  $S_3$ . The width of the wavelength band was adjusted by changing the width of slit  $S_1$ , which was the entrance slit of the monochromator system, while the slit  $S_2$  was always kept at a constant width of 100 μm. In the experiments reported here both the width of the optical bench entrance slit  $S_3$  and the width of the scanning exit slit  $S_4$  were kept constant at 20 μm. The widths of the slits mentioned so far were established conservatively with an accuracy of at least ±5%. The neutron wavelength distribution was determined by measuring the flight time of a chopped neutron beam along the full length of the optical setup. These flight-time distributions showed a flat constant intensity with tapering edges amounting only to a small fraction of the flight-time pattern. The bandwidth was then established as the distance

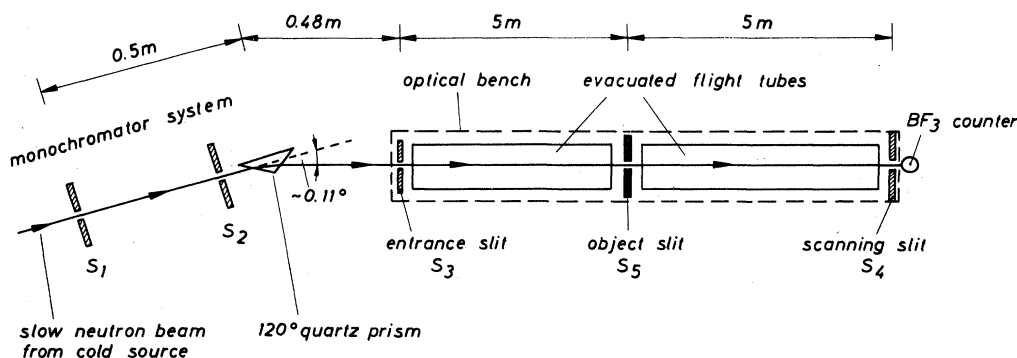

FIG. 1. Experimental setup (not to scale).

between the half-height points. The flight-time distributions were finally converted into wavelength distributions using the de Broglie relation in its standard nonrelativistic form.

In the experiments reported here, the diffracting object was another slit assembly (object slit  $S_5$ ) where specific care was exercised in order to adjust and align the slit edges precisely. All slit edges were made of a glass with high boron content ("Borosilikatglas" made by Vakuumschmelze Hanau, Federal Republic of Germany) to which 10%  $Gd_2O_3$  had been added in order to increase neutron absorption. The narrow 0.5-mm-wide flat faces along the beam had been polished by Zeiss, Federal Republic of Germany, with the parallelism of the edges better than  $1 \mu m$  over their overall height of 400 mm. For the slit that served as the diffracting object, only 60 mm of that full height were transmitted by neutrons during the actual experiments. The full height was used for adjusting the slits parallel to each other. A preliminary adjustment had been made using a theodolite, but the final adjustment was done with neutrons by covering different and varying parts of the slits used and by adjusting the vertical inclination of the slits until all diffraction patterns measured at different height combinations coincided. We estimate that the residual error in relative inclination of the various slits was less than  $1 \mu m$  over the height of the beam.

In order to avoid surface total reflection at the highly polished 0.5-mm-wide glass faces, the edges of the object slit were rotated away from the incident beam by an angle of about  $0.8^\circ$ . In principle, this may lead to an increase of the effective slit width by neutron penetration through the edges. We did estimate this effect in two different ways. First, it was found that a ray penetrating through the material at a distance of about  $0.3 \mu m$  away from the edge was already attenuated by a factor of more than  $1/e$ . Second, a ray  $0.1 \mu m$  from the edge would experience a phase shift of about  $2\pi$  relative to a ray through the slit opening, implying that neutrons passing through that edge would be refracted by angles of the order of  $10^{-2}$  rad and hence be deflected out of the diffraction pattern region measured.

The object slit width was also established in two different ways. On the one hand, the thickness of metal sheet spacers was measured, which had been used for defining the widths of the opening gap. On the other hand, the slit width was measured directly using a traveling microscope and illuminating the slit such that the slit edges and the slit opening were judged to be of about equal brightness.

The exit slit  $S_4$  was scanned over the diffraction pattern in a noncontinuous way, i.e., the slit was moved by a predetermined step width and then the neutrons were counted for a fixed time with the slit not moving. This scanning procedure was repeated a number of times and the finally obtained diffraction patterns displayed in this paper were then the sums of these individual scans with no further data adjustment.

### III. NUMERICAL CALCULATIONS

For comparison with theory, extensive numerical calculations were performed. Because of the vertical symmetry of the experiment we could restrict these calculations to two dimensions, i.e., neglect the vertical direction. The amplitude at a given point  $P$  in the observation plane due to a point source in the entrance slit  $S_3$  is then

$$u(P) \propto \int e^{ik(r+s)} dS_5, \quad (1)$$

where  $r$  is the length of a path from a source point to a point in the object slit located in the diffraction plane and  $s$  the length of a path from there to observation point  $P$ . The integration is done over the diffracting object slit  $S_5$ . Equation (1) is a coherent summing over the individual paths through the diffracting slit. Initially we consider the entrance slit  $S_3$  to be illuminated with a single plane wave, which implies a coherent sum over the individual source points in the entrance slit. Therefore the amplitude at the point of observation  $P$  (due to a single plane wave incident on  $S_3$ ) becomes

$$U(P) \propto \iint f(\delta\vartheta) e^{ik(r+s)} dS_3 dS_5, \quad (2)$$

with  $f(\delta\vartheta)$  describing the variation of the relative phase of the source points excited by the plane wave incident at angle  $\delta\vartheta$ .

The integration over the distribution  $w(\delta\vartheta)$  of the different incident directions present, i.e., over the angular divergence of the radiation, was then performed on the intensity level. This means that neutrons incident from different directions onto the entrance slit  $S_3$  were assumed to be incoherent with respect to each other. Likewise, the integration over the wavelength distribution  $w(\lambda)$  was also done incoherently. This assumption is justified because a static experiment can never reveal the wave-packet nature of the radiation studied (Klein, Opat, and Hamilton, 1983; Bernstein and Low, 1987). In a final integration step the finite width of the exit slit  $S_4$  had to be taken into account by summation over exit slit points. The final intensity therefore is

$$I \propto \iiint |U(P)|^2 w(\lambda) w(\delta\vartheta) d\lambda d(\delta\vartheta) dS_4. \quad (3)$$

In a series of preliminary calculations the number of integration points was determined as the minimum number necessary to achieve stable results better than experimental accuracy. It should also be mentioned that for optimum agreement with experiment it was found that it was better to assume in the calculations the exit slit to be just a few micrometers larger than its actual size. This is understood easily on the basis of some minute errors left in the alignment of the experimental setup and of small long-time drifts. Also, no method of measuring reliably the background intensity exists on the level of our experimental accuracy. Therefore we had to leave the background level as a free parameter. The background count rate thus obtained from the best fit of the experimental intensity distributions is of the order of 0.1

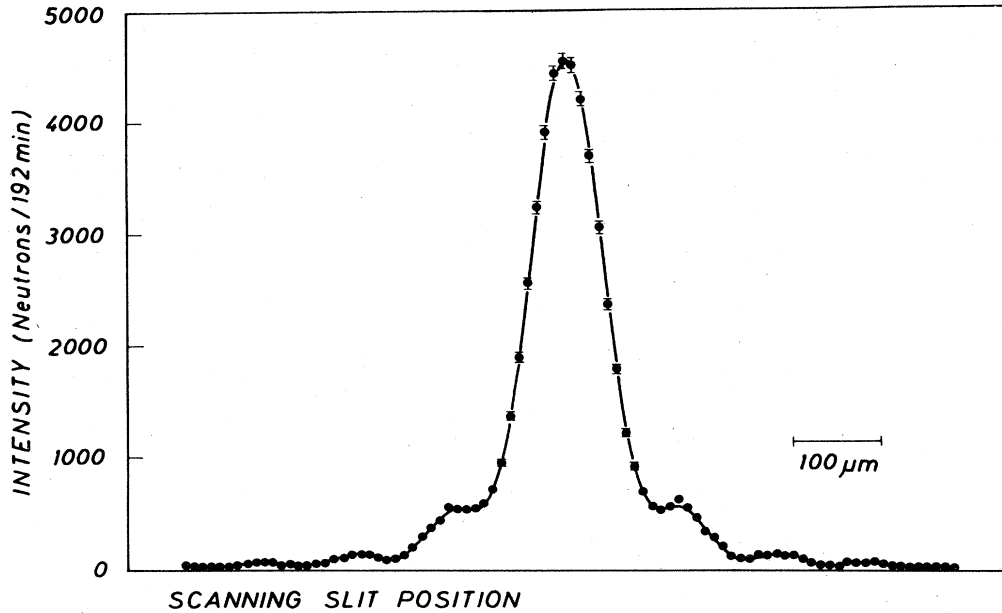

FIG. 2. Diffraction pattern of the wide single slit ( $90 \mu\text{m}$  nominal width). The solid curve is the theoretical calculation.

neutrons/min, which is of the expected order of magnitude.

#### IV. SINGLE-SLIT RESULTS

Experiments were performed mainly with a single slit of  $90 \mu\text{m}$  nominal width. The neutron wavelength was  $\lambda = 19.26 \pm 0.70 \pm 0.02 \text{ \AA}$  (mean wavelength, bandwidth, error) during these experiments. In each individual scan

the neutrons were counted for 500 sec at every position of the exit slit  $S_4$ ; 23 scans were performed altogether. This resulted in a total measuring time of 11 500 sec per point. Since 100 points were measured, the measuring time for the whole pattern was 320 h or about two weeks at the Institut Laue-Langevin high-flux reactor.

Figure 2 shows the diffraction pattern obtained together with the best theoretical fit. In order to stress the detailed agreement in the shape of the curve, Fig. 3 displays the same curve again, but enlarged tenfold. The agree-

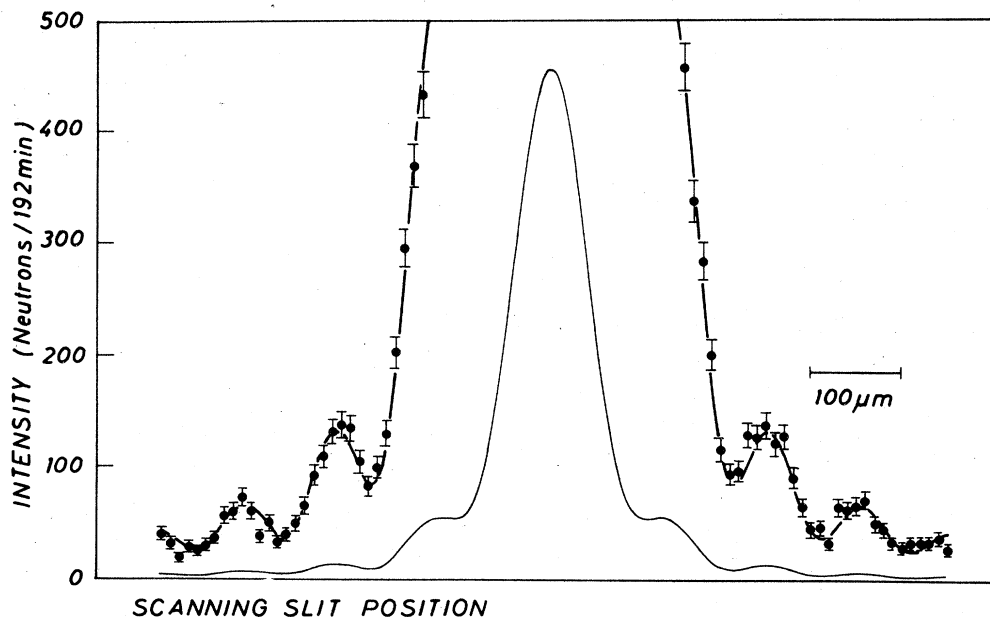

FIG. 3. Enlarged part of the nominal  $90\text{-}\mu\text{m}$  slit diffraction pattern. The solid curve is the theoretical calculation.

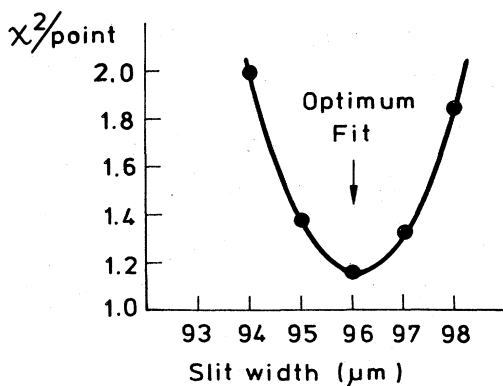

FIG. 4. Sensitivity of the  $\chi^2$  test to the slit width assumed in the theoretical calculation ( $90 \mu\text{m}$  nominal slit).

ment for the second-, third-, and even the fourth-order diffraction peak is excellent. We should stress again that the intensity of the fit was only adjusted through the total intensity of the pattern. Yet a distinct problem arises when one compares the slit width of  $96.07 \mu\text{m}$  used for calculating the optimum-fit theoretical curve with the independent measurements using an optical microscope ( $92.1 \pm 0.3 \mu\text{m}$ ) or determining the thickness of the metal spacers ( $91.5 \pm 0.4 \mu\text{m}$ ). The error of the independent slit measurements was found by comparing individual series, while the error of the theoretical fit may be estimated to be at most of the order of  $0.3 \mu\text{m}$ , being caused mainly by edge penetration.

The discrepancy mentioned above is significant from the statistical point of view, as Fig. 4 demonstrates. It was found during the numerical calculations that the

high sensitivity of  $\chi^2$  to the slit width was caused by the data in the higher-order maxima shown in Fig. 3. A fit of the central maximum alone is much less sensitive to the slit width. The discrepancy is certainly in need of an explanation. One possibility is hinted at by the fact that the optical microscope result of the slit measurement is very sensitive to the illumination condition chosen. For example, a microscope measurement with illumination of the slit assembly from the back and not also from the front gives a slit width in agreement with the neutron results. Yet we consider this optical measurement as not reliable, since there the slit appears as being bright on a dark background, which clearly leads to an overestimate of the slit width. Furthermore, we note, the width as established from the thickness of the spacers also disagrees with the neutron result but agrees with the microscope measurements. Therefore we have to admit that presently we do not have an explanation for the discrepancy found. Repetition of the experiment seems to be the only possible way to elucidate the effect.

No such discrepancy was found in another experiment with a slit of  $20 \mu\text{m}$  nominal width at the same wavelength. The independent measurement of the width of that slit did result in  $23.0 \mu\text{m}$ , while the optimum-fit parameter was  $22.7 \mu\text{m}$ , well within experimental accuracy (Fig. 5). The sensitivity of  $\chi^2$  to the slit width is much lower here because we had only the central peak available from the experiment. We also mention that during these experiments with the smaller slit the scanning exit slit  $S_4$  was widened to a width of  $60 \mu\text{m}$ . The measuring time per point was 300 sec for each individual scan, and 75 scans were performed. This resulted in a total measurement time of 22 500 sec per point, or 200 h for the whole pattern.

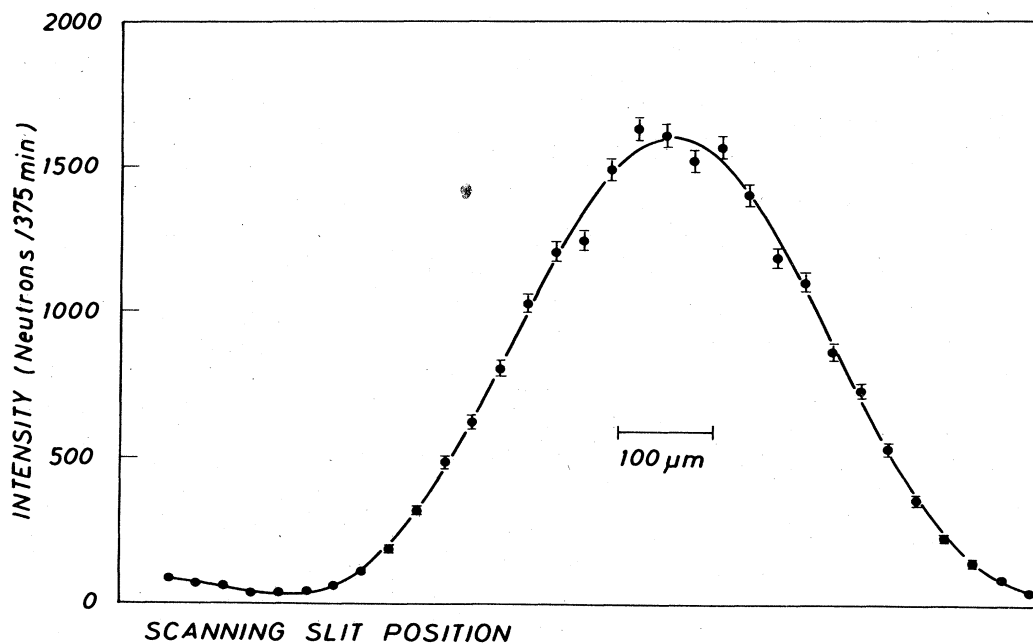

FIG. 5. Diffraction pattern of the  $23\text{-}\mu\text{m}$  single slit. The solid curve is the theoretical prediction.

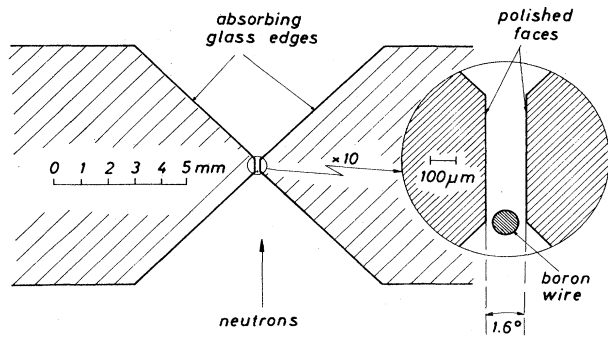

FIG. 6. Horizontal section through the double slit.

## V. DOUBLE-SLIT RESULTS

A double-slit assembly was obtained by mounting into the opening gap of a slit with a nominal width of  $150\ \mu\text{m}$  a highly absorbing boron wire (Fig. 6). In that experiment, because of time limitations imposed on us by the scheduling of the beam time, the neutron intensity had to be increased by admitting a broader wavelength band. The neutron wavelength was then  $\lambda = 18.45 \pm 1.40 \pm 0.02\ \text{\AA}$  (mean wavelength, bandwidth, error). Neutrons were counted for 500 sec per point again and 15 scans were performed, resulting in a total measuring time of 7500 sec per point, or about 210 h for the whole pattern.

The agreement with theory is excellent in this case

(Fig. 7). The result of the microscope measurement of the dimensions of the double-slit arrangement was  $21.9\text{--}104.1\text{--}22.5\ \mu\text{m}$  (left slit–boron wire–right slit), while the optimum fit resulted in  $21.5\text{--}104.1\text{--}22.3\ \mu\text{m}$ , which is in reasonable agreement with experimental accuracy. With regard to the error of the slit widths, we estimate here that neutrons penetrating through the boron wire along a chord  $0.2\ \mu\text{m}$  away from the surface are attenuated by more than a factor  $1/e$ . Moreover, such neutrons would be refracted far out of the diffraction pattern.

The double-slit experiment has often been called the most fundamental realization of a quantum phenomenon. For Feynman (Feynman, Leighton, and Sands, 1965), it “. . . has in it the heart of quantum mechanics. In reality, it contains the *only* mystery.” We believe that the experiment reported here is its most precise realization hitherto for matter waves. In view of the excellent agreement of our double-slit experiment with quantum-mechanical prediction, we suggest that any proposals for alternative theories should be checked in great detail against our experimental evidence.

*Note added in proof.* The experiment on the diffraction at a single slit of  $100\ \mu\text{m}$  nominal width was completely repeated recently (M. Gruber, R. Gähler, and A. Zeilinger, unpublished) with still higher statistical accuracy. In the new experiment, photons from a laser source were diffracted at the single slit under the same geometrical conditions as the neutrons. The discrepancy reported above between neutron and photon results was observed again and it had the same sign and magnitude.

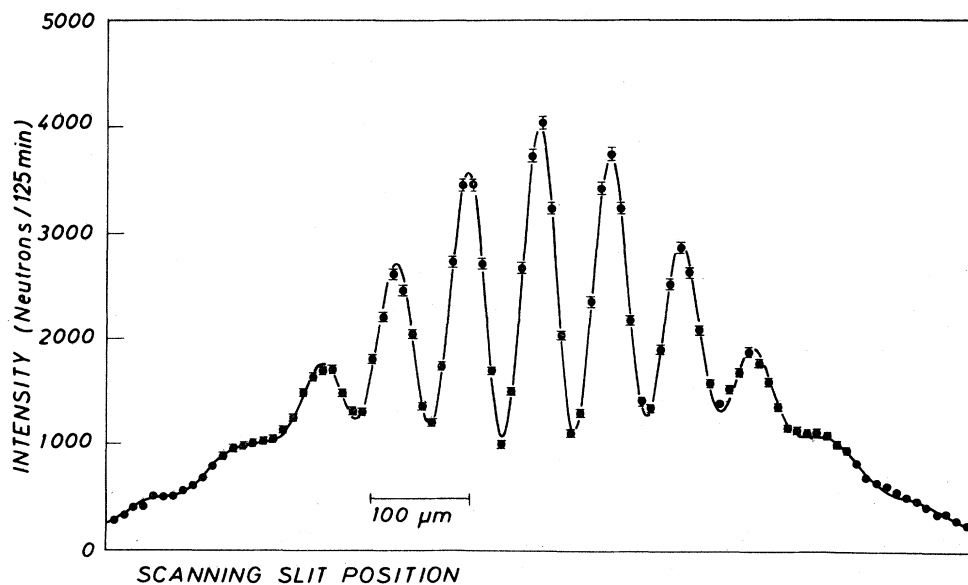

FIG. 7. Double-slit diffraction pattern. The solid curve represents the first-principles theoretical prediction. The slight asymmetry is explained by the known small inequality of the widths of the two slits.

## ACKNOWLEDGMENTS

We wish to thank the Institut Laue-Langevin for the possibility of performing these experiments there and Professor Kalus (Bayreuth) for generously lending us his optical bench assembly. This work was supported in part by the Austrian Fonds zur Förderung der wissenschaftlichen Forschung Projects Nos. S42-01 and P6635 and in part by the U.S. National Science Foundation under Grant No. DMR 87-13559.

## REFERENCES

- Baumann, J., J. Kalus, R. Gähler, W. Mampe, and B. Alefeld, 1988, *Physica B* **151**, 130.
- Bernstein, Herbert J., and Francis E. Low, 1987, *Phys. Rev. Lett.* **59**, 951.
- Feynman, R. P., R. B. Leighton, and M. Sands, 1965, *Quantum Mechanics, The Feynman Lectures on Physics, Vol. 3* (Addison-Wesley, Reading, Mass.).
- Gähler, R., J. Kalus, and W. Mampe, 1982, *Phys. Rev. D* **25**, 2887.
- Gähler, R., A. G. Klein, and A. Zeilinger, 1981, *Phys. Rev. A* **23**, 1611.
- Graf, A., H. Rauch, and T. Stern, 1979, *Atomkernenergie* **33**, 298.
- Jönsson, C., 1961, *Z. Phys.* **161**, 454.
- Jönsson, C., 1974, *Am. J. Phys.* **42**, 4.
- Kearney, P. D., A. G. Klein, G. I. Opat, and R. Gähler, 1980, *Nature (London)* **287**, 313.
- Klein, A. G., P. D. Kearney, G. I. Opat, A. Cimmino, and R. Gähler, 1981, *Phys. Rev. Lett.* **46**, 959.
- Klein, A. G., P. D. Kearney, G. I. Opat, and R. Gähler, 1981, *Phys. Lett. A* **83**, 71.
- Klein, A. G., G. I. Opat, and W. A. Hamilton, 1983, *Phys. Rev. Lett.* **50**, 563.
- Klein, A. G., and A. Zeilinger, 1984, *J. Phys. (Paris)* **43**, Colloque C3, 239.
- Kurz, H., and H. Rauch, 1969, *Z. Phys.* **220**, 419.
- Maier-Leibnitz, H., and T. Springer, 1962, *Z. Phys.* **167**, 386.
- Möllenstedt, G., and C. Jönsson, 1959, *Z. Phys.* **161**, 472.
- Rinard, Philip M., 1976, *Am. J. Phys.* **44**, 70.
- Scheckenhofer, K.-A., and A. Steyerl, 1977, *Phys. Rev. Lett.* **39**, 1310.
- Shull, C. G., 1969, *Phys. Rev.* **179**, 752.