

# Feynman and the visualization of space-time processes

Silvan S. Schweber

*Department of Physics, Brandeis University, Waltham, Massachusetts 02254*

The Shelter Island conference in 1947 was the stimulus for many of the important advances in quantum field theory following World War II. Schwinger, Feynman, Tomonaga, and Dyson were the principal contributors during the initial phase of these developments. This article attempts to reconstruct the genesis of Feynman's formulation of quantum electrodynamics, focusing principally on the period from 1947 to 1950.

## CONTENTS

I. Introduction	449
II. Background	451
A. Childhood	451
B. Undergraduate days: MIT	452
C. Graduate studies: Princeton	455
III. Ph.D. Dissertation	461
IV. Los Alamos and Going to Cornell	465
A. The war years	465
B. Coming to Cornell	467
C. Researches: 1946	468
V. The Genesis of the Theory	474
A. Shelter Island and its aftermath	474
B. Classical cutoffs	477
C. Elimination of radiation oscillators	479
D. Theory of positrons	485
E. Renormalization	489
VI. The Pocono Conference	491
VII. The Finishing Touches	495
A. Vacuum polarization	495
B. Evaluating integrals	498
C. The January 1949 APS meeting	499
D. Retrospective	501
VIII. Epilogue: Style and Visualization	504
Acknowledgments	505
References	505

## I. INTRODUCTION

During the first few days of June 1947, a conference on "The Foundations of Quantum Mechanics" was held at Ram's Head Inn on Shelter Island at the eastern tip of Long Island.<sup>1</sup> Six months after the conference, Darrow (1948), who had convened the conference, wrote D. MacInnes, who had been instrumental in organizing it,

I must quote [you]—the words of warm commendation used yesterday by I. I. Rabi anent your Shelter Island meeting—he said it has proved much more important than it seemed even at the time, and would be remembered as the 1911 Solvay Congress is remembered, for having been the starting-point of remarkable new developments . . . .

<sup>1</sup>For a history of the Shelter Island conference, see Schweber (1984,1985).

The meeting turned out to be one of the most seminal conferences to be held right after the end of World War II, a conference whose impact was indeed comparable to that of the Solvay Congress of 1911. Just as the Solvay Congress of 1911 set the stage for all the subsequent developments in quantum theory (de Broglie and Langevin, 1912; de Broglie, 1951), Shelter Island provided the initial stimulus for the post-World-War-II developments in quantum field theory: effective, relativistically invariant, computational methods; Feynman diagrams, renormalization theory.

The Shelter Island conference was the second of a series of small conferences that were held under the auspices of the National Academy of Sciences (NAS). Between 1946 and 1951, some eleven such conferences were organized—six on topics in physics. All eleven were highly successful and influential (Schweber, 1986). They were the result of a proposal by Duncan MacInnes of the Rockefeller Institute that the NAS sponsor a series of two- or three-day conferences, which were to have 25 or fewer persons in attendance and which would emphasize discussions rather than the presentation of papers. Only agendas were to be prepared, rather than any definite program, and a few appointed experts would lead the discussions, which were to take place without formality.

Three of the first four physics conferences—Shelter Island in 1947, Pocono in 1948, and Oldstone in 1949—dealt primarily with topics in theoretical physics<sup>2</sup> and were attended almost exclusively by theorists<sup>3</sup> (Fig. 1). At Shelter Island the results of experiments by Lamb and Retherford (1947) and by Nafe, Nelson, and Rabi (1947) on the fine and hyperfine structure of hydrogen were presented. These precision experiments, made possible by the wartime advances in microwave technology, indicated that deviations existed from the predictions of the Dirac equation for the spectrum of an electron in a Coulomb

<sup>2</sup>The fourth was a conference on *Low Temperature Physics* organized and convened by J. C. Slater and held at Shelter Island from 31 May through 2 June 1948.

<sup>3</sup>The caption to Fig. 1 lists those in attendance at the Shelter Island conference. The discussion leaders were Kramers, Oppenheimer, and Weisskopf.



FIG. 1. Participants at the Shelter Island conference (left to right): I. I. Rabi, L. Pauling, J. Van Vleck, W. E. Lamb, G. Breit, D. MacInnes, K. K. Darrow, G. E. Uhlenbeck, J. Schwinger, E. Teller, B. Rossi, A. Nordsieck, J. von Neumann, J. A. Wheeler, H. A. Bethe, R. Serber, R. E. Marshak, A. Pais, J. R. Oppenheimer, D. Bohm, R. P. Feynman, V. F. Weisskopf, H. Feshbach (not in the picture, H. A. Kramers). Courtesy of the Archives of the National Academy of Sciences.

field. By presenting reliable and precise values for these discrepancies, Lamb and Rabi posed a challenge to the theoretical community that could not be ignored. The result of the Lamb-Retherford experiment became one of the central and dominant concerns of the meeting.

At the conference Kramers, one of the discussion leaders, reviewed the difficulties that had been encountered in quantum electrodynamics since its inception in 1927, and focused principally on the divergences stemming from the (infinite) self-energy of a pointlike charged particle. He then outlined his own work (Kramers, 1938,1944) and that of his students, Serpe (1940) and Opechowski (1941), as a way out of the self-energy problem. He indicated how a theory could be formulated in which all structure effects had been eliminated and described "how an electron with *experimental mass* behaves in its interaction with the electromagnetic field" (Kramers, 1947). The elimination of structure effects corresponded to a mass renormalization, in which the self-

energy of a charged particle,  $\delta m$ , was combined with its (bare) mechanical mass  $m_{\text{mech}}$  and the sum identified with the observable experimental mass of the particle,  $m_{\text{expt}} = m_{\text{mech}} + \delta m$ . Kramers's suggestion—that observables be expressed in terms of the thus identified experimental mass of the electron—was the point of departure of Bethe's famous calculation of the Lamb shift (Bethe, 1947), which confirmed the feeling expressed at Shelter Island that the effect was a quantum-electrodynamical one.

The history of the Shelter Island, Pocono, and Oldstone conferences chronicles the development of quantum electrodynamics from 1947 to 1950 and tells the story of how Schwinger, Feynman, and Dyson worked out their respective contributions—work for which Schwinger and Feynman shared the Nobel prize with Tomonaga in 1965.

The initial accomplishment of Schwinger in the period 1947–1949 was the formulation of a somewhat unwieldy but coherent and systematic apparatus for doing

quantum-electrodynamic calculations, in which the ideas of mass and charge renormalization could readily be incorporated, and the demonstration that these methods could be successfully applied to problems that had experimental verification [e.g., the computation of the electron's anomalous magnetic moment, the Lamb shift, the radiative corrections to Coulomb scattering (Schwinger and Weisskopf, 1948; Schwinger, 1948a, 1948b, 1949a, 1949b)]. Feynman (1949b, 1949c) provided deep new insights by visualizing electromagnetic processes in a manner that translated these intuitive representations into simple, extremely efficient and effective calculational methods for computing observable quantities. For the first time one could conceive of doing higher-order calculations routinely. Dyson (1949a, 1949b) made a major contribution to the understanding of field theories with his examination and classification of the higher-order contributions, his analysis of the structure of quantum field theory to all orders of perturbation theory, and his formulation of the concept of renormalizability. Feynman diagrams, in addition to their intuitive appeal, can also be viewed as a representation of the logical content of field theories as stated in their perturbative expansions. It is this aspect of diagrammatics which enabled Dyson to obtain his insights into the structure of quantum field theory. He indicated how Feynman's visual insights could be translated into answers to the question whether charge and mass renormalization were sufficient to remove all the divergences in quantum electrodynamics to all orders of perturbation theory, and what renormalizability implied for other theories.

The present paper focuses on Feynman's contribution to these developments. It attempts to reconstruct the genesis of Feynman's formulation of quantum electrodynamics. It is organized as follows: After some background biographical material (Sec. II) it outlines Feynman's work for his Princeton dissertation (Sec. III). Section IV picks up Feynman's researches after the war. Section V details his activities from the Shelter Island conference to the Pocono conference. Section VI recounts his presentation at the Pocono conference. Section VII chronicles the final stages of the synthesis. A final section briefly addresses Feynman's style.

## II. BACKGROUND

*"He [Feynman] is a second Dirac, only this time human."*

E. P. Wigner<sup>4</sup>

<sup>4</sup>As quoted by J. R. Oppenheimer in a letter to R. Birge in 1943; in Smith and Weiner (1980), p. 269.

### A. Childhood

When I was a child I noticed that a ball in my express wagon would roll to the back when I started the wagon, and when I stopped suddenly it would roll forward. I asked my father why, and he answered as follows: "That, nobody knows! People call it inertia, and the general rule is that anything at rest tends to remain at rest, and a thing in motion tends to keep on moving in the same direction at the same speed. By the way, if you look closely you will see that when you start the wagon the ball doesn't really move backwards, but it just doesn't start up from rest as fast as does the wagon when you pull it, and it is the back of the wagon which moves toward the ball." (Feynman, 1954b).

Feynman has very vivid memories of his father. One of his earliest and most joyous recollections is that of his father taking him to the Museum of Natural History in Manhattan and telling him about glaciers: "I can hear his voice, [as he] explained to me about the ice moving and grinding . . ." (Feynman, 1966b). His father often played games with him and constantly challenged him by posing problems for him. Their interaction was primarily verbal, and solving problems by talking about them became a pattern with Feynman. In their discussions, his father stressed that facts *per se* were not important; what mattered was the process of finding things out. Skepticism, disrespect for authority were other traits that his father inculcated in him. But his father also got him the *Encyclopedia Britannica*, and the young Feynman avidly read through many of its entries. Feynman recalls with sadness his shock as a young teenager when he discovered that his father's answers to his mathematical and scientific questions were no longer adequate.

Feynman's father, Melville, immigrated to the United States from Russia as a boy of 5 and grew up in Patchogue, Long Island. Upon graduating from high school he enrolled in a homeopathic medical institute, but chose not to practice. Feynman's mother, Lucille Phillips, came from a well-to-do family and attended the Ethical Culture School in New York, but did not go to college thereafter. She was a bright and lively person, and she was responsible for the cheery atmosphere that permeated the Feynman household. She never worked for money, but devoted her time to a variety of charitable causes (J. Feynman, 1984). During Feynman's childhood, his father was involved in various business undertakings, but he was not very successful in any of them. Financial difficulties were responsible for the family's moving from Far Rockaway to Cedarhurst and back again to Far Rockaway. However, during the 1930s the financial situation gradually improved and the family became relatively well off (J. Feynman, 1985).

Richard Phillips Feynman was born on 11 May 1918. A younger brother, born when Feynman was 4 or 5, died shortly after birth. The other member of the family is a sister, Joan, some nine years younger than Richard. Feynman attended both junior and senior high school in Far Rockaway and was fortunate to have some very gift-

ed teachers in chemistry and mathematics (Feynman, Leighton, and Sands, 1964, Vol. II, p. 19-1). He recalls (Feynman, 1966b) the "real pleasure" of doing chemistry experiments after school while in junior high school. During this same period, a lecture on heavy water by Harold Urey made a deep impression on him. Feynman had read about Urey, and the lecture was "good and technical, and it was fun. And that was my first contact with a real scientist" (Feynman, 1966b). Commenting on the experiments in chemistry and electricity that he performed as a teenager in his laboratory at home, Feynman points out that he "never played chaotically with scientific things"; he realized even then the importance of doing "things" in a controlled fashion, carefully, and watching what happened (Feynman, 1966b).

Feynman's mathematical talents manifested themselves early. Many things seemed obvious to him. When he had learned the meaning of an exponent as a high school freshman, it was intuitively clear to him that the solution of  $2^x = 32$  was  $x = 5$ . As a sophomore, in 1933, he worked hard on the problem of the trisection of an angle with only compass and ruler and had fantasies about the acclaim he would receive upon solving the problem. During the same year, Feynman taught himself trigonometry, advanced algebra, infinite series, analytic geometry, and the differential and integral calculus. His progress is recorded in notebooks he kept at the time (Feynman, 1933-1934). What is noteworthy about their content is the thoroughness and the practical bent they display. Feynman was not content to master the formal, theoretical aspects of trigonometry: his notes contain a table of sines, cosines, and tangents from  $0^\circ$  to  $90^\circ$  in  $5^\circ$  steps that he computed himself by various ingenious schemes. Similarly his mastering of the calculus is recorded in a special notebook—a green "Scribble-in-Book" marked on the cover "The Calculus" and given the title "The Calculus for the Practical Man" on the first page (Feynman,

COMPLEX NUMBERS

Since any numbr, real, or pure or complex imaginary, is of the form  $a+bi$  and can shown on the graph adjoining.

On the figure:

$$\tan \theta = b/a$$

$$\text{nat}(b/a) = \theta$$

Letting  $OR = r$ :

$$\sin \theta = b/r$$

$$\cos \theta = a/r$$

$$a + bi = r(\cos \theta + i \sin \theta)$$

But: (see page 54 of M):  $e^{i\theta} = \cos \theta + i \sin \theta$

So:  $a + bi = r e^{i\theta}$  But:  $\theta = \text{nat}(b/a)$

Or:  $a + bi = r e^{i \text{nat}(b/a)}$

Now will this work for real numbers and in what way?

in this case  $b = 0$ ; therefore  $\text{nat} 0 = 0$  or  $\theta = 0$  or  $2\pi$  etc

$$a + 0i = r e^{i \cdot 0} = r e^{i \cdot 2\pi}$$

Since  $e^0 = 1$ ; and;  $e^{i 2\pi} = 1$  what is  $(r)$

$r = (a + 0i)^{1/2}$  from the diagram; rt. tri.  $OR$

So the complete answer is  $a + bi = (a + 0i)^{1/2} e^{i \text{nat}(b/a)}$

If  $(a + 0i)^{1/2} = m$ ; and  $\text{nat}(b/a) = n$  all numbers are of the form;  $m e^{in}$

Or in other words all numbers can be shown to be a certain constant times that remarkable numbr  $(e)$  to another constant times that other remarkable numbr  $i$ , power, which is truly a remarkable thing.

Thus what is  $i$  in this formula firstly  $a = 0$  and  $b = 1$

Or  $m = (a + 0i)^{1/2} = 1$

and  $n = \text{nat}(1/0) = \text{nat} \theta = \pi/2$  or  $3\pi/2$  or  $5\pi/2$  etc.

$$e^{i \pi/2} = i$$

FIG. 3. Feynman's notes on complex numbers using his typewriter symbols (Feynman, 1933-1934).

1933-1934)—which contains extensive tables of integrals that Feynman had worked out. Already he exhibited the need to recast what he had learned in his own language. Feynman's presentation of complex numbers, conic sections, and other topics of advanced algebra are contained in a carefully typed manuscript dated November 1933. Since his typewriter did not have keys for mathematical symbols such as plus, equal, multiplication, and integral signs, Feynman devised "typewriter symbols" for them (Fig. 2) enabling him to type out all his notes (Fig. 3). The manuscript also contains a lengthy table of integrals that he had compiled, for which he invented an elaborate notation.

**B. Undergraduate days: MIT**

Feynman entered MIT in the fall of 1935 a rather difficult, but ambitious, young man. He initially declared his major to be mathematics. During the fall semester of his freshman year he went to Philip Franklin, the head of the mathematics department, and asked him "What is the use of higher mathematics besides teaching more mathematics?" Franklin answered, "If you have to ask that, then you don't belong in mathematics." So he switched to "practical" engineering (Feynman, 1985a). But while he was still a freshman, helping two seniors who lived in his fraternity house with the problems in a graduate physics course they were taking from Slater convinced Feynman

TYPEWRITER SYMBOLS		
*	plus	Can't write the other
-	minus	" " " "
:	times	" " " "
/	divide by	" " " "
=	equals	" " " "
∫	integral	" " " "
∂	differencial	" " " "
∫ <sub>a</sub> <sup>b</sup>	definite integral	" " " "
π	pi # 3.1416	" " " "
∞	infinity	" " " "
x <sup>2</sup>	x square	" " " "
x	x	" " " "

EXAMPLE(SEE BELOW)

$$\int (x^2 + a^2)^{-1/2} dx = \frac{1}{2} \ln(x^2 + a^2) + \frac{1}{2} \log_e(x^2 + a^2)$$

FIG. 2. The typewriter symbols Feynman devised for his 1933 manuscript on complex numbers, analytic geometry, and the calculus (Feynman, 1933-1934).

that he wanted to major in physics. As a sophomore he enrolled in that same course—Physics 8.461: “Introduction to Theoretical Physics”—which that year was being taught by J. Stratton from the book of the same name by Slater and Frank (1933).

Feynman (1966b) remembers coming to Stratton's course in his ROTC uniform—“a dead giveaway” of his sophomore status—and filling out a pink registration card that was to be given to the instructor; seniors and graduate students had cards of different colors, green and brown, respectively. Although he was a little worried—he was only a sophomore after all—he was proud of being there and felt “pretty good,” since almost everyone else was filling out green and brown cards. The only other student in the class wearing an ROTC uniform and also filling out a pink card sat down next to him. His name was Theodore Welton. Welton and Feynman had met briefly the previous spring at the annual open house at the end of their freshman year.

Before coming to Stratton's first lecture, Welton had gone to the Physics Library and had gotten out Levi-Civita's *The Absolute Differential Calculus*, which he hoped would deepen his knowledge of differential geometry. His interest in that field had been kindled after reading Eddington's *The Mathematical Theory of Relativity* the previous year. When Feynman noticed the books Welton had, he announced “in a somewhat raucous Far Rockaway version of standard English” (Welton, 1983) that he had been trying to “get ahold” of Levi-Civita and could he see it when Welton was finished with it. Welton for his part observed that Feynman's stack of books contained the library's copy of *Vector and Tensor Analysis* by A. P. Wills, which explained why he had been unable to locate it. Since they were the only two sophomores in the class, it apparently occurred to them simul-

taneously “that cooperation in the struggle against a crew of aggressive-looking seniors and graduate students might be mutually beneficial” (Welton, 1983). From that moment a deep friendship developed between the two of them.

Stratton quickly recognized Feynman as a truly superior student. Because of the pressure of other duties, at times Stratton would skimp on preparation and come to an embarrassed halt during his lecture. With only a moment's hesitation he would then turn to Feynman and ask for his help. Whereupon, Feynman would walk somewhat diffidently to the blackboard and indicate how to proceed, “always correct[ly] and frequently ingeniously” (Welton, 1983).

Welton remembers an “amazing” quirk displayed by Feynman in Stratton's course: his “maddening refusal to concede that Lagrange might have something useful to say about physics. The rest of us were appropriately impressed with the compactness, elegance, and utility of Lagrange's formulation, but Dick stubbornly insisted that real physics lay in identifying all the forces and properly resolving them into components” (Welton, 1983). Nonetheless, Feynman would always obtain the correct equations of motion using his physical intuition and his previously gained insights. This insistence disclosed more than a quirk: it revealed Feynman's fierce independence and his need to do and understand things his own way.

During their first conversation, the afternoon of that memorable first class with Stratton, Feynman told Welton that he wanted to learn general relativity. Welton, “with proper superiority” announced that he already knew some general relativity and wanted to learn quantum mechanics. Whereupon Feynman suggested to Welton that he take a look at Dirac, the “good book on the subject” he had read. Welton, upon reading Dirac, rapid-

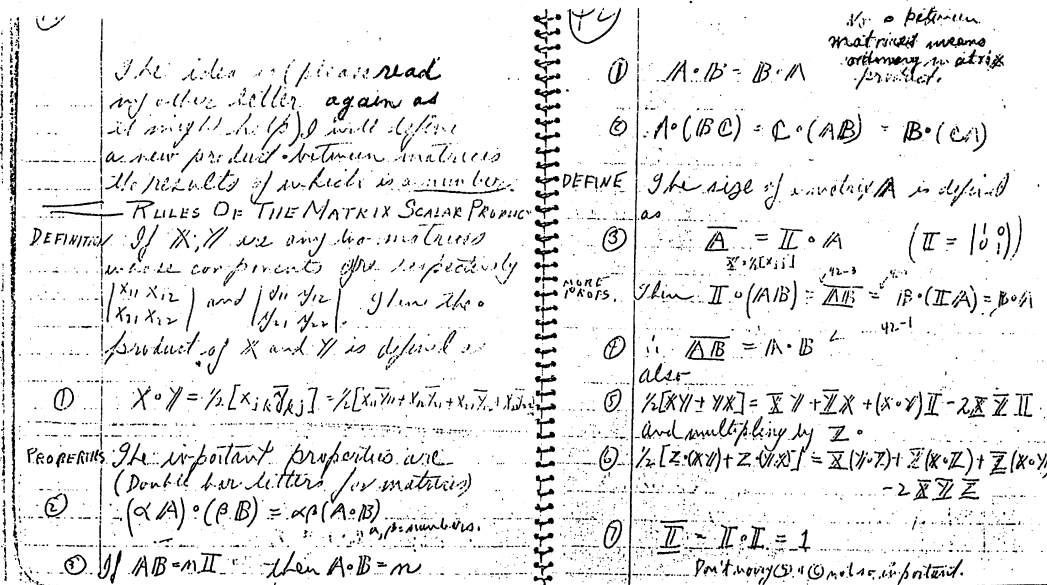

FIG. 4. A page from the notebook that Feynman and Welton exchanged during 1936–1937 when they were sophomores at MIT (Feynman and Welton, 1936–1937).

ly found himself over his head. Somehow they located a more appropriate text, Pauling and Wilson's *Introduction to Quantum Mechanics*, and together "wandered through much of quantum mechanics" during that fall semester (Welton, 1983).

During their sophomore year, while taking the courses they had enrolled in, Feynman and Welton taught themselves general relativity and together explored relativistic quantum mechanics, exchanging ideas, problems, and possible solutions in a notebook that went back and forth between them (Feynman and Welton, 1936–1937). They rediscovered the Klein-Gordon equation, and Feynman remembers very distinctly Welton's asking whether one could calculate the energy levels of a hydrogen atom with this equation to see whether it agreed with experiments (Feynman, 1966b). "Remember what I said about your equation having been tried and found wrong. I saw that in Dirac's book," Welton writes to Feynman in their notebook during the summer of 1936. "Why don't you apply your equation to a problem like the hydrogen atom, and see what results it gives?" (Feynman and Welton, 1936–1937). Feynman assesses the negative results they obtained as a "terrible" and very important lesson. He learned from it to rely neither on the beauty of an equation nor on its "marvelous formality": the test was "to bring it down against the real thing" (Feynman 1966b).

To get an indication of the caliber of these two eighteen-year-old sophomores, here is an excerpt from another of Welton's entries in the joint notebook during the summer of 1936:

Here's something. The problem of an electron in the gravitational field of a heavy particle. Of course the electron would contribute to the field, but I think that could be neglected. Take your equation ( $K=0$ ) and substitute for  $g^{\mu\nu}$  the values in the field of the particle

$$[g^{\mu\nu}P_\mu P_\nu + m^2 c^2]\psi = 0.$$

I wonder if the energy would be quantized? The more I think about the problem the more interesting it sounds. I am going to try it . . . .<sup>5</sup>

I'll let you know the result later. I'll probably get an equation that I can't solve anyway. That's the trouble with quantum mechanics. It's easy enough to set up

equations for various problems, but it takes a mind twice as good as the differential analyzer to solve them.

The entry concludes with Welton's comment

I can't arouse much interest any more in classical quantum mechanics (Schrödinger's equation, etc.). Relativistic wave mechanics is the only stuff (Feynman and Welton, 1936–1937).

The notebook also exhibits Feynman's mathematical virtuosity: normed matrix vector spaces are casually introduced, laborious tensor calculations are elegantly dispatched, and his affinity for useful notation repeatedly displayed (Fig. 4).

In 1937, the spring semester of "Introduction to Theoretical Physics," Physics 8.462, was taught by Philip Morse, who included in his course lectures on wave mechanics. Impressed by the problem sets Feynman and Welton were handing in and by the questions they were asking during and after the lectures, Morse invited Feynman, Welton, and a junior in the class, Al Glogston, to come to his office for one afternoon a week the next year to be properly exposed to quantum mechanics. They all accepted with alacrity.

During the fall semester of their junior year Feynman and Welton carefully studied Dirac's *Quantum Mechanics* with Morse. Clogston (1984) remembers "most vividly . . . the chastening encounter with Dick Feynman's quick mind" and how hard he had to work to keep up. After they had gone through Dirac, Morse informed Feynman and Welton that they were ready for a "little real research" and suggested some calculations of atomic properties, using a formulation of the variational method which he had just published (Morse and Vinti, 1933; Morse, Young, and Haurwitz, 1935; Slater, 1969). This they did, and in the process they learned a great deal about hydrogenic—Feynman called them "hygienic"—wave functions and became nimble-fingered experts on Marchant calculating machines—the "chug-chug-ding-chug-chug-ding . . ." hand-operated calculators of those prewar days (Welton, 1983).

In his senior year Feynman took a metallurgy course to

<sup>5</sup>Welton, on a previous page, had commented on "Feynman's equation"

$$[(P_\mu - K_\mu)g^{\mu\nu}(P_\nu - K_\nu) + m^2 c^2]\psi = 0, \quad K_\mu = \left[ \frac{e}{c} A_1, \frac{e}{c} A_2, \frac{e}{c} A_3, -e\varphi \right].$$

It is worth noting that Welton actually wrote down the Schwarzschild metric and indicated how he would do the calculation:

Let's see in a grav. field of a particle

$$ds^2 = \left(1 - \frac{2m}{r}\right) dr^2 + r^2(d\theta^2 + \sin^2\theta d\varphi^2) - \left(1 - \frac{2m}{r}\right) dt^2$$

I think that's right.

So,

$$\left[\left(1 - \frac{2m}{r}\right)P_r^2 + r^2P_\theta^2 + r^2\sin^2\theta P_\varphi^2 - \left(1 - \frac{2m}{r}\right)P_t^2 + m^2\right]\psi = 0, \quad c = \text{unity}$$

I'll work out the Christoffel symbol and find explicit expressions for  $P_r^2$ ,  $P_\theta^2$ ,  $P_\varphi^2$ , and  $P_t^2$ .

learn about the applications of physics and a laboratory course given by George Harrison. Welton recalls Harrison's lectures as "a pleasure to attend, with a wealth of ingenious applications of physical principles" (Welton, 1983).<sup>6</sup> The laboratory required a project, and Feynman there exhibited his great gadgeteering ingenuity in a mechanism to obtain the ratio of the speeds of two rotating shafts. Feynman and Welton in their last year at MIT also took a seminar given by Morse and Frank, in which they studied the review articles on nuclear physics that Bethe and Livingston (Bethe, 1937; Livingston and Bethe, 1937) had recently published.

By the time Feynman finished his undergraduate studies at MIT in 1939 he had mastered many of the fields of theoretical physics. In the tutorial Philip Morse had given him, he had learned quantum mechanics well enough to write a senior dissertation under Slater on "Forces and Molecules" (Feynman, 1939a), in which his impressive formal and calculational talents are manifest. This research was published in the *Physical Review* and contains a result now known as the Feynman-Hellman theorem (Feynman, 1939b). He worked with Vallarta (Vallarta and Feynman, 1939) on cosmic-ray problems and with Harrison and Herring on aspects of solid-state physics. He also had spent a great deal of time in the library reading a vast number of advanced texts: "I was very avid for reading and studying and learning" is the way Feynman (1966b) puts it.

At MIT, Feynman's outstanding abilities were clearly recognized. He had done so well in all his courses that the Department of Physics "had taken the unusual step of proposing that he be granted his bachelor's degree at the end of three years instead of four" (Morse, 1977, p. 126). While at MIT, Feynman changed from a somewhat shy, insecure, and timid teenager to a confident—indeed brash—young man. There he also shed his fear of women.

In his autobiography, Morse recalls Feynman's father coming to MIT from New York in the fall of 1938 and telling him, "My son Richard is finishing his schooling here next spring. Now he tells me he wants to go on to do more studying, to get still another degree. I guess I can

afford to pay his way for another three or four years. But what I want to know is, is it worth it for him? ... Is he good enough ...? Will it help him?" (Morse, 1977, pp. 125–126). Morse assured him that his son was the brightest undergraduate he had ever met and, yes, "he really needed the extra schooling to be able to enter his chosen profession" (Morse, 1977, p. 126). Feynman would have liked to stay on at MIT for his graduate studies, but Slater insisted that he go elsewhere. Although he had not applied to Harvard, Feynman was offered a scholarship to study there because he had won the national Putnam contest in mathematics.<sup>7</sup> But he declined the invitation as he had already agreed to go to Princeton University and had accepted the Physics Department's offer to let him be Wigner's research assistant.

### C. Graduate studies: Princeton

As it turned out he was assigned to be Wheeler's assistant—a propitious event in retrospect. John Archibald Wheeler, who had just come to Princeton as a twenty-six-year-old assistant professor in the fall of 1938, proved to be an ideal mentor for the young Feynman. Full of bold and original ideas, "a man who had the courage to look at any crazy problem, a fearless and intrepid explorer" (Wilson, 1979, p. 213), Wheeler gave Feynman viewpoints and insights into physics which would prove decisive later on. Feynman recalls that when they first met, Wheeler indicated to him that they would have a limited and fixed amount of time to discuss things during their scheduled meetings. When Feynman appeared at Wheeler's office for their first conference, Wheeler took out his pocket watch and put it on the table so that he could see how much time had elapsed and how much time was left. After this initial meeting Feynman bought himself a dollar pocket watch. At their next scheduled conference, when Wheeler put his watch down on the table Feynman took out *his* watch and put it down on the table. Wheeler thereupon burst out laughing and so did Feynman. They both laughed so hard that they could not stop and could not get to work for a while (Feynman, 1966b). This revealing incident marked the beginning of a lasting friendship and of a seminal association between two minds that complemented each other. Wheeler's brilliance, the wildness of his apparently impossible ideas fell on fertile ground.

The first problem Wheeler assigned Feynman was to explain the shape of the Compton line in the scattering of

<sup>6</sup>In a brief "Scientific Autobiography" appended to the articles on "Discovery of Positronium" in Maglich (1975), Martin Deutsch, who was an undergraduate at MIT at the same time as Feynman, remarks

It was Harrison's junior course in atomic physics that had the greatest influence on me [as an undergraduate at MIT]. The course was totally disorganized, and seemed to consist of a series of scientific anecdotes or vignettes. Somehow this style kindled my enthusiasm, and I still charge many of the insights into physics and the creative process which I acquired there to this influence.

Incidentally, Deutsch remembers Feynman as "standing out" among his fellow students.

<sup>7</sup>When the mathematics department at MIT had discovered that they did not have the four men needed to enter a team for the Putnam contest, they asked Feynman to join the competition. Looking at their records, they had found that Feynman had been in mathematics. Feynman (1985a) recalls "I was unsure, but they gave me old exams to practice on."

x rays by atoms, in order to learn what it revealed about the momentum distribution of the electrons in the atom. It was in this context that Feynman first learned of Wheeler's work on the scattering matrix (Wheeler, 1937). Wheeler gave him lectures on scattering theory and presented his view that all quantum-mechanical descriptions of physical phenomena could be construed as scattering processes. In particular, he indicated to him how one could interpret the Schrödinger equation as describing a succession of scattering events.

While working on these problems, Feynman continued to spend time on an idea he had fallen "deeply in love with" (Feynman, 1966b) as an undergraduate at MIT, an idea on how to solve the difficulties plaguing quantum electrodynamics (QED). While at MIT Feynman had become acquainted with the leading problems in quantum electrodynamics by reading the books by Dirac (1935) and Heitler (1936). He knew that in classical theory the self-energy of a point charge was infinite, and he had studied various schemes that had been put forward to solve or bypass this difficulty. In his Nobel Prize lecture, he recalls that his understanding of the problem in the quantum theory was much hazier. It seems he believed that there the divergence arose from the fact that one was dealing with a *field* system with an infinite number of degrees of freedom, each degree having a finite zero-point energy (Feynman, 1966a, p. 700).

To overcome both these difficulties he put forth the following "quite evident" suggestions: First, that a charged particle does not act on itself, it acts only on other charged particles. Second, he postulated that there was no electromagnetic field, in order to eliminate the infinite number of degrees of freedom associated with the electromagnetic field. Since the field was completely determined by the motion of the charged particles, it could be expressed in terms of the particle variables. The field therefore did not have any independent degrees of freedom and the infinities he had associated with them could then be removed. "The general plan was first to solve the classical problems . . . and to hope that . . . [in] a quantum theory . . . everything would just be fine . . ." (Feynman, 1966a, p. 700).

By the time he came to Princeton, Feynman had noted "a glaringly obvious fault" with his theory (Feynman 1966a, p. 700). Self-interaction was necessary to account for the radiation resistance. He had learned that Lorentz had used the action of a charged particle on itself to explain the force of radiation resistance. More work is required to accelerate a charged particle than a neutral one because an accelerated charge radiates. A charged particle did seem to act on itself; and moreover this force was necessary to preserve the conservation of energy.

Feynman hoped that, nonetheless, he would be able to patch up his theory by considering the reaction back on the radiating particle from the induced motion of the other charges affected by the radiation. He presented his ideas to Wheeler, who immediately pointed out its flaws: "The answer you get for the problem with . . . two charges . . . unfortunately will depend upon the charge

and the mass of the second charge and will vary inversely as the square of the distance,  $R$ , between the charges, while the force of radiation resistance depends on none of these things. . . . Finally when you accelerate the first charge, the second acts later, and then the reaction back here at the source would still be later . . . the action occurs at the wrong time" (Feynman, 1966a, p. 700).

Wheeler went on to give a lecture on possible modifications of Feynman's approach. Suppose, Wheeler suggested, "that the return action by the charges in the absorber reaches the source by advanced waves as well as by the ordinary retarded waves of reflected light, so that the law of interaction acts backward in time, as well as forward in time . . ." (Feynman, 1966a, p. 700). Wheeler used advanced waves to get the reaction back at the right time and then noted that, if the advanced waves came back from the absorber phase shifted (but, by assumption, unchanged in wavelength), then by a suitable adjustment of the index of refraction of the absorber, the action at the source of these advanced waves was completely independent of the properties of the charges of the absorber and was, moreover, of the right character to represent radiation reaction. Wheeler asked Feynman to calculate how much advanced and how much retarded waves would be needed to get the reaction effects numerically right, and to "figure out what happens to the advanced effects that you would expect if you put a test charge . . . close to the source . . . [i.e.] why would that test charge not be affected by the advanced waves from the source?" (Feynman, 1966a, p. 701).

At the time Feynman attributed Wheeler's insights to his natural brilliance. He was not aware that since coming to Princeton Wheeler had been studying the action-at-a-distance formulations of electromagnetic theory of Schwarzschild (1903), Tetrode (1922), Frenkel (1925), and Fokker (1929, 1932a, 1932b). While working with Breit in 1933, Wheeler (1967) became convinced

that the great white hope of theoretical physics was the electron-positron theory and that people had been too early and too glib and too facile in ruling out the idea of the electron in the nucleus; that pair theory offers mechanisms for binding electrons in very small regions of space that never got a thorough discussion in these off-hand comments of why there couldn't be electrons in the nucleus . . . . I didn't leave the idea that electrons were the basic building materials until 1947. And the fanaticism with which I pursued that view is shown I guess not least by the fact that I felt that if electrons were the building blocks of atomic nuclei, the forces that were involved would not be the static electric forces but the radiation components of the forces. Therefore, it was of great importance to understand the influences set up by a rapidly accelerated electron.

The interactions of highly accelerated relativistic electrons was thus a subject of great interest to Wheeler, and he had discussed these matters with Léon Rosenfeld during the latter's visit to Princeton in the spring of 1939. Wheeler had tried to meet Rosenfeld's objections "that electromagnetic radiation seemed to have no place in this picture" (Wheeler, 1979, p. 258), and he recalls that



"Sometime later, reflecting quietly at home one Sunday afternoon on the back of an envelope, I suddenly recognized that if there were enough absorber particles around to absorb completely the radiation from an accelerated source, it would make no difference how numerous were these particles, nor what their properties. However, I failed by a factor of 2 to get the right result for the familiar force of radiative reaction. The next day I told Richard Feynman, then a graduate student, about my line of thought and about my results. Thanks to our usual lively discussion the factor two was cleared up along with many other ramifications" (Wheeler, 1979, p. 258).

Feynman indeed discovered that one could account for radiation resistance if one assumed all actions are via half advanced and half retarded solutions of Maxwell's equation and that all sources are surrounded by material absorbing all the light emitted. Radiation resistance could then be explained as "a direct action of the charges of the absorber acting back by advanced waves on the source" (Feynman, 1966a, p. 701).

Feynman remarks that when Wheeler first suggested using advanced waves so that the law of interaction also acts forward in time—a concept at first sight at variance with elementary notions of causality—he was enough of a physicist not to say "No, how could that be?" Rather he felt that this was like theorizing in the old days with Bohr. He had learned from the history of physics, in particular from Einstein's and Bohr's work, that "an idea which looks completely paradoxical at first, if analyzed to completion in all its details and in experimental situations, may in fact not be paradoxical" (Feynman, 1966a, p. 700).

Wheeler and Feynman worked out the details of their action-at-a-distance theory in the fall of 1940 (Wheeler and Feynman, 1945). Feynman gave a colloquium on their work that was attended by Einstein, Pauli,<sup>8</sup> Von Neumann, Wigner, and Henri Norris Russell, among others. Feynman recalls Wigner's trying to reassure him before the lecture and to convince him not to worry. "If Professor Russell falls asleep during your lecture," Wigner told him, "it does not mean it's no good, it's just

because Professor Russell always falls asleep; but he is listening. And if Professor Pauli is nodding 'yes' during the entire lecture don't be too impressed, because . . . [he] has palsy and nods 'yes' all the time" (Feynman, 1966b). Before his lecture, Feynman had filled all the blackboards in the room with equations. He remembers getting up to give the lecture and opening the envelope that contained his notes with a shaking hand:

I can see the shaking hand. Because it was quite a thing. And I started to talk about the subject. And then a thing happened that has happened ever since, and is just great: as soon as my mind got on the physics and trying to explain it, and organize the ideas, how to present it, there was no more worrying about the audience as personalities! It was all in terms of physics. I was calm, everything was good, I developed the ideas, I explained everything to the best of my abilities.

Immediately after Feynman had finished, Pauli got up and criticized the theory. Neither Feynman nor Wheeler (1981) nor Wigner (1981) remembers Pauli's objections to the theory, but Feynman does remember Einstein's comments. Einstein cautioned that, although the idea of action at a distance involved in the Wheeler-Feynman theory was not consistent with the field views expressed by general relativity, general relativity was not as well established as electrodynamics. He, Einstein, would therefore not use that argument against the theory, because one could perhaps also develop a different way of doing gravitational interactions (Feynman, 1966b).

Wheeler had been scheduled to give a lecture on how to quantize their action-at-a-distance theory at the next meeting of the colloquium. After Feynman's lecture, while walking back from Fine Hall to Palmer Labs with Feynman, Pauli asked him what Wheeler was going to say. Feynman replied that he did not know. "Oh" said Pauli, "the professor doesn't tell his assistant how he has it worked out? Maybe the professor hasn't got it worked out!" As it turned out, Wheeler had in fact overestimated his results, and he canceled the lecture. Feynman was impressed by Pauli's astuteness (Feynman, 1966b).

In the spring of 1941 Feynman (1941) wrote up a 21-page draft of a paper entitled "The Interaction Theory of Radiation," which concisely summarized what had been worked out. The assumptions of the theory were clearly spelled out:

## II. PRINCIPLES OF THE INTERACTION THEORY

We make the following assumptions:

- (1) The acceleration of a point charge is due only to the sum of its interactions with other charged particles (and to "mechanical forces"\*) . A charge does not act on itself.
- (2) The force of interaction which one charge exerts on a second is calculated by means of the Lorentz force formula,\*\* in which the fields are the fields generated by the first charge according to Maxwell's equations.

<sup>8</sup>Pauli had come to the United States in 1940 because he had feared that Switzerland might be overrun by Germany. In any case, he was vulnerable because his parents had been Jewish, and he still carried an Austrian passport and was considered a German citizen after the Anschluss in 1938. When approached about working on the atomic bomb, he indicated that he was uncertain whether he should go into research directly connected with the war. From Los Alamos, Oppenheimer (1943) convinced him that it would be "a waste and an error" for him to do that, he being "just about the only physicist in the country who can help to keep those principles of science alive which do not seem immediately relevant to the war, and that is eminently worth doing" (Oppenheimer, 1943; see Smith and Weiner, 1980, pp. 257–259).

(3) The fundamental (microscopic) phenomena in nature are symmetrical with respect to interchange of past and future.<sup>9</sup>

(4) The limit of the velocity of each charge for increasingly remote (past or future) times is less than the velocity of light.

According to the second assumption alone, the force exerted by one charge on a second might be obtained from the field derived from the retarded potentials of Lienard and Wiechert. Thus, the second charge would be affected by an amount determined by the *previous* motion of the first charge. This is not the only possibility, however; one could, for example, use the advanced potentials. In this case the second charge would be affected by an amount depending on the *later* motion of the first charge. The requirement that the effects be unchanged if one interchanges past and future removes the ambiguity and demands that one utilize one-half the retarded plus one-half the advanced potentials to calculate the force on the second point charge due to the first. This is exactly the law of interaction that one derives from the principle of least action of Fokker, and that principle may well have formed the starting point of this theory.

We shall now discuss the application of this law to some simple idealized situations in order to get an idea of its physical meaning.

In the first place, we notice that a single accelerating charge in otherwise charge-free space will radiate no energy. There can be no radiative damping, since there are no electrodynamic fields acting on the charge, no other charges being present to generate such fields.

\*The present theory is one to describe those phenomena which are usually considered to be due to electromagnetic effects. Forces on charged particles such as nuclear forces on protons, or "quantum forces" on electrons, will be classified as "mechanical" forces and will not be discussed further in this paper.

$$**\text{Force} = e \left[ \mathbf{E} + \frac{\mathbf{v}}{c} \times \mathbf{H} \right]$$

Next, Feynman presented the explanation he and Wheeler had given for the mechanism of radiation damping in their absorber model, and then addressed the problem of runaway solutions that Dirac had encountered.

Feynman gave his manuscript to Wheeler, who reworked it and expanded it. Wheeler (Wheeler and Feynman, 1942) returned a new, unfinished manuscript to Feynman in the spring of 1942. By then, Wheeler was deeply involved in war work at the Metallurgical Laboratory at the University of Chicago and could no longer de-

vote any time to this project. The title of the new manuscript was "Action at a Distance in Classical Theory: Reaction of the Absorber as the Mechanism of Radiation Damping." Most of it is to be found in the paper Wheeler and Feynman submitted to the Festschrift celebrating Niels Bohr's 60th birthday (Wheeler and Feynman, 1945).<sup>10</sup>

In this newer version, they gave an elegant explanation of how radiation damping occurred.

When there are  $n$  particles interacting, the field acting on particle 1 is

$$F_{\mu\nu} = \sum_{n \neq 1} F_{\mu\nu}^{(n)}, \quad (2.1)$$

where

$$F_{\mu\nu}^{(n)} = \frac{F_{\mu\nu}^{(n) \text{ ret}} + F_{\mu\nu}^{(n) \text{ adv}}}{2} \quad (2.2)$$

and  $F_{\mu\nu}^{(n) \text{ ret}}$  and  $F_{\mu\nu}^{(n) \text{ adv}}$  are the retarded and advanced solutions of Maxwell's equations generated by particle  $n$ .

The field on particle 1 can also be rewritten as

$$\begin{aligned} F &= \sum_{n \neq 1} F_{\text{ret}}^{(n)} + \frac{1}{2} \sum_{n \neq 1} (F_{\text{adv}}^{(n)} - F_{\text{ret}}^{(n)}) \\ &= \sum_{n \neq 1} F_{\text{ret}}^{(n)} + \frac{1}{2} \sum_{\text{all } n} (F_{\text{adv}}^{(n)} - F_{\text{ret}}^{(n)}) - \frac{1}{2} (F_{\text{adv}}^{(1)} - F_{\text{ret}}^{(1)}). \end{aligned} \quad (2.3)$$

The term  $\frac{1}{2} (F_{\mu\nu}^{(1) \text{ adv}} - F_{\mu\nu}^{(1) \text{ ret}})$  had been shown by Dirac (1938) to give a force on particle (1) equal to

$$\frac{2}{3} e_{(1)} \left[ \frac{d^2}{ds^2} v_{(1)}^\mu \right] + \left[ \frac{dv_{(1)}}{ds} \right]^2 v_{(1)}^\mu, \quad (2.4)$$

which is just the Lorentz damping term.

The term

$$\frac{1}{2} \sum_n (F_{\text{adv}}^{(n)} - F_{\text{ret}}^{(n)})$$

vanishes if one has absorbing walls:

If a source radiates for a time, at a very long time afterwards the total retarded field vanishes, for all the light is absorbed. But also the total advanced field vanishes at this time (for charges are no longer accelerating and the advanced field exists only at times previous to their motion). Hence the difference vanishes everywhere at this time and, since it is a solution of Maxwell's homogeneous equations, at all times (Feynman, 1948a, p. 941, footnote 6).

A particle thus effectively interacts only with the retarded

<sup>9</sup>The original typewritten statement read:

(3) The fundamental equations are to be invariant with respect to interchange of the sign of the time in them (symmetrical with respect to interchange of past and future). and was changed by Feynman to the form indicated in the text.

<sup>10</sup>One of the subjects not dealt with by Feynman and Wheeler was the description of blackbody radiation within their absorber theory and more particularly how the Planck distribution gets established. This problem was addressed and solved by G. N. Plass (1946), in a Ph.D. dissertation with Wheeler.

fields of the other charged particles and experiences a Lorentz damping force due to its own acceleration. Although Wheeler and Feynman had started with a formulation symmetric with respect to past and future, they ended up with a solution that stressed the retarded character of the interaction—and that was the same as the one obtained by Dirac in 1938 using only retarded solutions of Maxwell's equation. Wheeler and Feynman attributed this to an asymmetry in the initial conditions with respect to time. The particles that constituted the absorber were assumed to be in random motion (or at rest), so that the sum of their retarded potentials had no effect on the acceleration of the source. The prevalence of retarded over advanced potentials was attributed to statistical considerations: the particles in the absorber tended to go from ordered to disordered states of higher entropy rather than vice versa. If the direction of time were reversed one could inquire as to the initial conditions necessary in order for advanced potentials to play the dominant role that retarded potentials play in the usual picture. For this to be the case it would appear as if the chaotic motion of the absorber became ordered, so that all the absorber particles were able to radiate in phase at precisely the right moment for the radiation to converge on the particle when it was accelerated. This latter set of initial conditions is much less probable than the first.<sup>11</sup>

The following statement of their views was given in Feynman's twenty-one page synopsis of their work:

It might be worthwhile to make a few remarks at this point about the irreversibility of radiative phenomena. We must distinguish between two types of irreversibility. A sequence of natural phenomena will be said to be microscopically irreversible if the sequence of phenomena reversed in temporal order in every detail could not possibly occur in nature. If the original sequence and the reversed in time one have a vastly different order of probability of occurrence in the macroscopic sense, the phenomena are said to be macroscopically irreversible.

The Lorentz theory predicts the existence of microscopically irreversible phenomena in systems which are not closed (for example, energy is always *lost* by the system to empty space as radiation). In our theory phenomena are microscopically reversible in any system. It seems at first sight, paradoxical that the two theories can ever lead to the same results, as they do in closed systems. The reason is that the phenomena predicted for closed systems are actually reversible even within the framework of the Lorentz theory which uses only retarded waves.<sup>(1)</sup> The apparent irreversibility in a closed system, then, either from our point of view or the point of view of Lorentz is a purely macroscopic irreversibility. The present authors believe that all physical phenomena are microscopically reversible, and that, therefore, all apparently irreversible phenomena are solely macroscopically irreversible.

<sup>11</sup>For an extended discussion of those matters see Gold and Schumacher (1967). Mr. X in that volume is R. P. Feynman. See Gold (1965).

<sup>(1)</sup>That this and the following statement are true in the Lorentz theory was emphasized by Einstein in a discussion with Ritz. (Einstein and Ritz, *Phys. Z.* 10, p. 323 (1909).) Our viewpoint on the matter discussed is essentially that of Einstein. (We should like to thank Prof. W. Pauli for calling our attention to this discussion.)

Feynman appended a handwritten note to the bottom of the page, which pointed to the last paragraph and which stated

Prof [*sic*; Feynman's erasure] Wheeler  
This is a rather sweeping  
statement. Perhaps you  
don't agree with it.  
RPF.

During the fall and winter of 1940 the theory had been formulated in many different versions. Its most elegant presentation was based on the observation that the equation of motion for the charged particles,

$$m^{(i)} \frac{dv_{\mu}^{(i)}}{d^{(i)}} = m^{(i)} v_{\mu}^{(i)} = e^{(i)} v_{\nu}^{(i)} \sum_{j \neq i} \frac{1}{2} (F_{\mu}^{(j)\nu} + F_{\mu}^{(j)\nu}) , \quad (2.5)$$

could be derived from Fokker's variational principle:  $\delta I = 0$ , with

$$I = \sum_i \int m^{(i)} ds^{(i)} + \sum_{i \neq j} \int \int e^{(i)} e^{(j)} \delta(R_{ij}^2) dz_{\mu}^{(i)} dz^{(j)\mu} , \quad (2.6)$$

where

$$R_{ij}^2 = (z_{\mu}^{(i)} - z_{\mu}^{(j)}) (z^{(i)\mu} - z^{(j)\mu}) .$$

$ds^{(i)} = (dz_{\mu}^{(i)} dz^{(i)\mu})^{1/2}$  is the proper time along the path of particle  $i$ , and  $m^{(i)}$  and  $e^{(i)}$  are the mass and charge of particle  $i$ .<sup>12</sup> The action  $I$  is a function of the coordinates  $z_{\mu}^{(i)}$  of the possible world lines of the particles. The actual world lines that the particles follow are distinguished from all possible world lines by the condition that the action function  $I$  be stationary,  $\delta I = 0$ , on the actual world lines with respect to small displacements from these lines. Because of the presence of the delta function, the particles interact only when they are on each other's light cones. Feynman later stated:

We have in [Fokker's action principle] a thing that describes the character of the path throughout all of space and time. The behavior of nature is determined by saying her whole space-time path has a certain character. For an action like [Fokker's] the equations obtained by variation [of  $z_{\mu}^{(j)}(s_j)$ ] are no longer at all easy to get back into Hamiltonian form. If you wish to use as variables

<sup>12</sup>The notation is that of Wheeler and Feynman (1945). It is explained in greater detail in Sec. V.B.

only the coordinates of particles, then you can talk about the property of the paths—but the path of one particle at a given time is affected by the path of another at a different time. If you try to describe, therefore, things differentially, telling what the present conditions of the particles are, and how these present conditions will affect the future—you see it is impossible with particles alone, because something the particles did in the past is going to affect the future (Feynman, 1966a, p. 702).

It was during this same period, the fall of 1940, while working out the space-time picture of action at a distance, that Wheeler called Feynman up one Saturday evening and told him

“Feynman, I know why all different electrons have the same charge and the same mass.”

“Why?” asked Feynman.

“Because they are all the same electron.”

And Wheeler explained over the phone:

“Suppose that the world lines which we were ordinarily considering before in time and space, instead of only going up in time, were a tremendous knot (Fig. 5) and then when we cut through all the knot, by the plane corresponding to a fixed time, we would see many, many world lines and that would represent many electrons—except for one thing. If in one section this is an ordinary electron world line in the section in which it reversed itself and is coming back from the future we have the wrong sign to the proper time—to the proper four velocity—and that's equivalent to changing the sign of the charge, and therefore that part of the path would act like a positron.”

“But,” said Feynman immediately, “there aren't as many positrons as electrons. Where are all the positrons?”

“Well,” answered Wheeler, “maybe they are hidden in the protons or something” (Feynman, 1966a, p. 702).

Feynman did not “take the idea that all the electrons were the same one . . . as seriously as the observation that positrons could simply be represented as electrons going from the future to the past in a back section of their world lines” (Feynman, 1966a, p. 702). The fact that Wheeler had a theory that could represent both electrons and positrons in classical physics in a very simple way “by letting the world lines go backwards and forwards in time” (Feynman, 1966a, p. 702) made an indelible impression on Feynman.

It should be remarked that the zigzag world line description of pair annihilation, unbeknownst to Wheeler, had also been put forward by Stückelberg (1941a, 1941b) at this same time.

An indication of some of Feynman's other interests and activities while at Princeton can be gleaned from a letter Wheeler wrote Feynman in 1949. At the time Wheeler was working with John Toll, then a graduate student, on the general relation between dispersion and absorption in quantum-electrodynamic processes. In the letter Wheeler (1949) requested the title and author of an article Feynman had reported on in 1941:

I'm writing you now because you gave a report at Journal Club one Monday evening in 1941 on the relation

between phase change and amplitude gain for a linear amplifier. The little black box had two input leads and two output leads. The magician was able to deduce all he needed from the requirement that energy shouldn't come out of the box on the right-hand side before it had been put in on the left. You were reporting on a paper about which I remember neither the author nor the title nor the journal . . .

I am having an interesting time trying to develop the theory of world lines, about which we once talked a little; a description of nature which makes no use of the concepts of space and time. But that is something else!

Soon thereafter, Feynman (1949e) answered Wheeler's query:

The article which I reported at the Journal Club in Princeton in 1941 was “Relations Between Attenuation and Phase in Feed-Back Amplifier Design” by A. W. Bode in the Bell System Technical Journal, Vol. 19, page 421, 1940. Unfortunately this paper gives only the relations between attenuation and phase and does not describe how they may be obtained. It was my guess at the time I described the paper that they were simply a consequence of the assumption that signals could not come out of the amplifier before they were put in. In mathematical laws this corresponds to the assumption that all singularities in the impedance relationship must occur for frequencies with positive imaginary parts. The rest I had hoped would result from some maneuvering Cauchy's theorem . . .<sup>13</sup>

The theory of world lines which we once spoke about has been subjected to investigation by somebody. I remember reading a long mathematical article on the subject in what I think was an English journal but I cannot remember the author's name nor the journal unfortunately [A. G. Walker, Proc. R. Soc. Edinburgh 67, 319 (1949)]. He seems to have gone somewhat further than I remember that we did but along almost exactly the same lines. He did not go far enough, however, to have something definite and interesting come of it. What do you think the quantum-mechanical analogue of that picture is?

<sup>13</sup>Feynman (1985a) relates that “in high school, I had a very able friend, Herbert Harris, who, when we graduated, went to Rensselaer Polytech to become an electrical engineer, while I went to MIT. One summer [probably at the end of their freshman year], he returned to Far Rockaway, we friends took a walk, and he told me about the then new feedback amplifiers. He tried to design them in different ways avoiding oscillations and said he was convinced that there was some law of nature that made it impossible to make the impedance fall off too fast without inducing a large phase shift. I proposed it might be a reflection into the frequency response domain of the fact that signals cannot come out before they come in. But neither of us was, apparently, sophisticated enough to work this out mathematically.” This is the reason why, four years later at Princeton, Feynman had found Bode's paper “so interesting.”

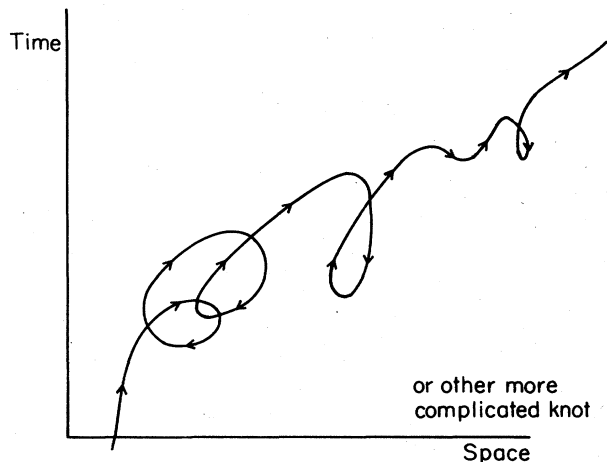

FIG. 5. Feynman's (1985a) representation of the "tremendous knot."

Feynman (1985b) has recounted some of his experiences as a graduate student in his autobiographical fragments "Surely, You're Joking Mr. Feynman!" *Adventures of a Curious Character*. Those who remember him from then corroborate his recollections but add another dimension to the picture he painted. Leonard Eisenbud, who was finishing his graduate studies in 1939 when Feynman came to Princeton, remembers sitting next to him in S. Bochner's lectures on complex variables: "It wasn't easy to be a classmate of his. He was so much brighter than anyone else." What impressed Eisenbud was not only Feynman's quickness and brightness but also "his risible quality. Under the laughter there was a brashness, but never to attack. He was very likable" (Eisenbud, 1984). Conyers Herring, who was a postdoctoral fellow at Princeton at that time, recalls that

His spontaneity and exuberance matched his remarkable scientific talents. I remember once being invited to his quarters to meet his fiancée, Arline Greenbaum, who had come down to New York for a visit. At that time she seemed to be in perfect health, and there was much hilarity. I remember acting out the part as he mimicked a sideshow barker, saying "He walks, he talks, he crawls on his belly like a reptile!" (Herring, 1984).

### III. Ph.D. DISSERTATION

Having solved the problem of expressing classical electrodynamics in a way that dispensed with the electromagnetic field, Feynman addressed the next step, which was to formulate its quantum theory. The classical theory when formulated in terms of Fokker's action principle involved two different times, which in turn meant that there was no Hamiltonian for the system. Thus the problem to be addressed was how to formulate the quantum theory of a system describable by an action principle of the form

$$S = \int L dt, \tag{3.1}$$

where  $L$  is the Lagrangian of the system, but which did not admit of a Hamiltonian. Feynman's doctoral dissertation, "The Principle of Least Action in Quantum Mechanics," which he presented to the Department of Physics in May 1942, shortly after joining the Manhattan project, solved the problem of "finding a quantum description applicable to [nonrelativistic] systems which in their classical analogues are expressible by a principle of least action, and not necessarily by Hamiltonian equations of motion" (Feynman, 1942, p. 6).

Wheeler, who also had been trying to quantize their absorber theory, at one stage told Feynman not to bother working on the quantization since he had already solved it. But since Wheeler had not shown Feynman his results, Feynman "still had to find out" (Feynman, 1966b).<sup>14</sup> Feynman first considered simple models, such as a harmonic oscillator interacting with another harmonic oscillator with a time delay ["Put the essential in, but keep everything else simple" (Feynman, 1966b)], and worked out the quantum-mechanical description of these toy models. But the results obtained from the analysis of such systems of interacting harmonic oscillators did not give "much of a clue as to how to generalize [them] . . . to other systems" (Feynman, 1966a, p. 703).

Then in the spring of 1941 the essential clue in arriving at a general solution was provided by Herbert Jehle, who was then visiting Princeton. At a Nassau Tavern beer party, Jehle, in answer to Feynman's query whether he knew of a way to go from a classical action to quantum mechanics without invoking a Hamiltonian, indicated that Dirac in 1932 had written a paper on how to go directly from a Lagrangian to the quantum theory (Dirac, 1932). In that discussion with Feynman, Jehle (1980) also made the point

that the Lagrangian formulation permits a more simple, straightforward relativistically covariant approach than the Hamiltonian method.

The next day they studied together Dirac's paper, which pointed out that the transformation matrix<sup>15</sup>

<sup>14</sup>After Feynman had developed the alternate formulation of quantum mechanics that he had obtained for his thesis, Wheeler again tried to quantize the Wheeler-Feynman theory. His approach consisted in linearizing the Fokker action using Dirac's trick of replacing  $(-da_\mu da^\mu)^{1/2}$  by  $\Gamma_\mu da^\mu$ . He sent his notes—consisting of some thirteen pages, dated November 1941—to Feynman at Los Alamos in 1945. They are among the Feynman papers at the CIT Archives (RPF, CIT, 3.1.0.).

<sup>15</sup>Since,  $L(t)$  is a time-dependent operator [which does not commute with  $L(t')$  for  $t \neq t'$ ], the expression

$$\exp \left[ \frac{i}{\hbar} \int_T^t L dt \right]$$

must be defined. The calculus of ordered operators that Feynman invented in 1947 gives explicit meaning to such expressions.

$$(q_t | q_T) \text{ "corresponds to" } \exp \left[ i \int_T^t L dt / \hbar \right]. \quad (3.2)$$

In the infinitesimal case this becomes

$(q'_{t+\epsilon} | q_t)$  corresponds to

$$\exp \left[ \frac{i}{\hbar} \epsilon L \left[ \frac{q' - q}{\epsilon}, q \right] \right] = \exp \left[ \frac{i}{\hbar} S(q'_{t+\epsilon}, q_t) \right], \quad (3.3)$$

i.e.,  $e^{(i/\hbar)S}$  is "analogous" to the quantity which in quantum mechanics carries the wave function of a particle—classically described by the Lagrangian  $L(q', q)$ —from time  $t$  to  $t + \epsilon$ . To understand what Dirac had meant by "analogous" Feynman (1966b) derived the Schrödinger equation for a particle whose Lagrangian was

$$L = \frac{1}{2} m v^2 - V(x) \quad (3.4)$$

and concluded that by "analogous" Dirac had meant "proportional," i.e., equal except for a proportionality constant. Feynman recalls that at the Princeton bicentennial celebration in the fall of 1946 he asked Dirac what he had meant by "analogous." "Did you know that they were proportional?" asked Feynman. "Are they?" Dirac inquired. "Yes," said Feynman. "Oh, that's interesting," was Dirac's final comment (Feynman, 1966b).

Feynman assumed that by virtue of Eq. (3.3) the wave function at time  $t + \epsilon$  of a particle described by the (inelastic) Lagrangian (3.4) is related to the wave function at time  $t$  by

$$\psi(q', t + \epsilon) = \int \frac{1}{A} \exp \left[ \frac{i\epsilon}{\hbar} L \left[ \frac{q' - q}{\epsilon}, q \right] \right] \psi(q, t) dq, \quad (3.5)$$

where  $A$  is a proportionality constant. In Jehle's presence he proved that Eq. (3.5) yields Schrödinger's equation

$$\left[ -\frac{\hbar^2}{2m} \frac{\partial^2}{\partial q^2} + V(q) \right] \psi(q, t) = i\hbar \frac{\partial}{\partial t} \psi(q, t), \quad (3.6)$$

provided

$$A = \left[ \frac{2\pi\hbar i t}{m} \right]^{1/2}. \quad (3.7)$$

In his paper Dirac had shown that  $(q_t | q_T)$  could be written as

$$(q_t | q_T) = \int \cdots \times \int (q_t | q_n) dq_n \cdots dq_m (q_m | q_{m-1}) dq_{m-1} \times \cdots (q_2 | q_1) dq_1 (q_1 | q_T), \quad (3.8)$$

where  $q_m$  refers to the intermediate time  $t_m$ . From Eq. (3.8) one infers that

$(q_t | q_T)$  corresponds to

$$\int \exp \left[ \frac{i}{\hbar} \int_T^t L dt \right] dq_N \cdots dq_1. \quad (3.9)$$

The finite-time transformation matrix could thus be written as

$$(q_t | q_T) = \lim_{\substack{N \rightarrow \infty \\ Nt = t - T}} \int \cdots \int \exp \left[ \frac{i}{\hbar} \int_T^t L dt \right] \frac{dq_1}{A} \frac{dq_2}{A} \times \frac{dq_3}{A} \cdots \frac{dq_N}{A}, \quad (3.10)$$

a result Feynman obtained by dividing the time interval  $T \rightarrow t$  into a large number of small intervals of duration  $\epsilon$ ,  $T \rightarrow t_1, t_1 \rightarrow t_2 \cdots t_N \rightarrow t$ ,  $N\epsilon = t - T$ , by introducing a sequence of intermediate times  $t_m = T + m\epsilon$ .

Dirac (1932) had also indicated how in the limit as  $\hbar \rightarrow 0$  the only important contribution in the domain of integration of the  $q_k$  came from those  $q_k$ 's for which a comparatively large variation produced only a very small variation in  $\int L dt$ —which corresponds to the set of points  $q_1 \cdots q_N$  for which  $\int L dt$  is stationary with respect to small variations in  $q_k$ , i.e., the classical path. Equation (3.8) was, however, not interpreted by Dirac as an integral over paths: that interpretation is implicit in Feynman's thesis and became explicit when Feynman wrote up his formulation of quantum mechanics for the *Reviews of Modern Physics* in 1947.

Although no diagrams appear in that paper (Feynman, 1948c), the quantum-mechanical amplitude  $(q't' | qt)$  is conceived of as receiving a contribution from each allowed path  $\Gamma$  that connects  $qt$  to  $q't'$  (Fig. 6).

Each path  $\Gamma$  contributes a phase  $e^{(i/\hbar)S(\Gamma)}$  to the total amplitude, where  $S(\Gamma)$  is the action computed for the path  $\Gamma$ ,

$$S(\Gamma) = \int_{\Gamma}^t L(q, \dot{q}, t) dq. \quad (3.11)$$

The total amplitude is given by

$$(q't' | qt) = \frac{1}{A'} \sum_{\substack{\text{over all paths } \Gamma \\ \text{from } qt \text{ to } q't'}} e^{(i/\hbar)S(\Gamma)}, \quad (3.12)$$

where  $A'$  is a normalization constant.

These visual aspects of the integral-over-paths approach to quantum mechanics were not stressed in Feynman's thesis, although it is clear that the conceptual-

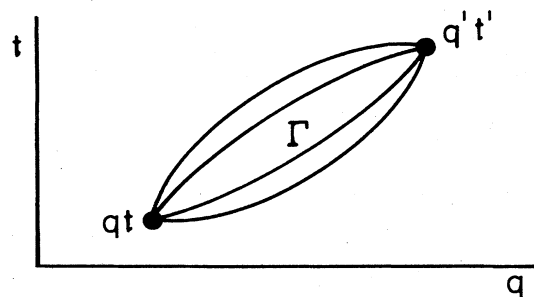

FIG. 6. Paths that join the space-time points  $qt$  and  $q't'$ .

ization of the transformation function ( $q't' | qt$ ) in terms of space-time trajectories is central to the enterprise. In later years Feynman would stress the equivalence of his approach to those of Heisenberg, Dirac, and Schrödinger and would suggest that this multiplicity of possible descriptions of quantum phenomenon attests to our having captured key elements in our description of atomic phenomena—this multiplicity being an expression and “representation of the simplicity of nature” (Feynman, 1966a, p. 702). In 1941, however, Feynman conceived of his formulation as a generalization of the quantum mechanics of Dirac, Heisenberg, and Schrödinger, valid in circumstances when the usual approach presented insurmountable obstacles or proved intractable or impotent. In point of fact, Feynman's formulation could handle situations where the ordinary concept of a wave function was inadequate. Thus for a system of particles that interact with a time delay, the concept of a wave function is not a convenient way of expressing information about the system. Feynman formulated this theory in terms of transition amplitudes (to go from one condition to another), clearly influenced by the *S*-matrix viewpoint Wheeler had expounded to him.

The conclusion of his thesis summarized both the accomplishments and the difficulties of the formalism:

## 12. Conclusion

We have presented, in the foregoing pages, a generalization of quantum mechanics applicable to a system whose classical analogue is described by a principle of least action. It is important to emphasize, however, some of the difficulties and limitations of the descriptions presented here.

One of the most important limitations has already been discussed. The interpretation of the formulas from the physical point of view is rather unsatisfactory. The interpretation in terms of the concept of transition probability requires our altering the mechanical system, and our speaking of states of the system at times very far from the present. The interpretation in terms of expectations, which avoids this difficulty, is incomplete, since the criterion that a functional represent a real physical observable is lacking. It is possible that an analysis of the theory of measurements is required here. A concept such as the “reduction of the wave packet” is not directly applicable, for in the mathematics we must describe the system for all times, and if a measurement is going to be made in the interval of interest, this fact must be put somehow into the equations from the start. Summarizing: a physical interpretation should be sought which does not refer to the behavior of the system at times very far distant from a present time of interest.

A point of vagueness is the normalization factor, *A*. No rule has been given to determine it for a given action expression. This question is related to the difficult mathematical question as to the conditions under which the limiting process of subdividing the time scale, required by equations such as (45.1), actually converges.

The problem of the form that relativistic quantum mechanics, and the Dirac equation, take from this point

of view remains unsolved. Attempts to substitute, for the action, the classical relativistic form (integral of proper time) have met with difficulties associated with the fact that the square root involved becomes imaginary for certain values of the coordinates over which the action is integrated.

The final test of any physical theory lies, of course, in experiment. No comparison to experiment has been made in the paper. The author hopes to apply these methods to quantum electrodynamics. It is only out of some such direct application that an experimental comparison can be made.

The author would like to express his gratitude to Professor John A. Wheeler for his continued advice and encouragement (Feynman, 1942, pp. 73–74).

In order to confront the meaning of measurements in his more general version of quantum mechanics, in those cases when the concept of a wave function was inapplicable, Feynman had to understand fully the more conventional approaches of the quantum theory of measurement, and in particular Von Neumann's formulation of the measurement problem (Von Neumann, 1932). He was dissatisfied with Von Neumann's solution “that it does not make any difference where you made the cut, but you had to make some cut” because it left the possibility that there was a “vital force” (Feynman, 1980b). It seemed to him quite possible that there was no “vital force,” and he did not want to decide that ahead of time from the principles of quantum mechanics. Moreover he felt that it was unsatisfactory to have part of the world not described by quantum mechanics. While still a graduate student, he discussed these problems with Von Neumann at the Institute for Advanced Study. As Feynman (1980b) recalls,

It didn't seem possible, really honestly to have decided that there must be a part that wasn't involved, just because I never really believed that philosophical things like that were really sound and even though you might want to use that to make an easy explanation, it was incomplete.

So he tried to find a way to give an objective definition of a measurement and arrived at the following statement: If you could correlate the position of a piece of the world with other pieces, then if the other pieces (or their action or energy or something) would go to infinity and the correlation approached a finite value, that thing is measurable. In 1946, as he was preparing his article, he wrote himself a little note on the subject:

When you start out to measure the property of one (or more) atom, say, you get, for example, a spot on a photographic plate which you then interpret. But such a spot is really only more atoms & so in looking at the spot you are again measuring the properties of atoms, only now it is more atoms. What can we expect to end with if we say we can't see many things about one atom precisely, what in fact can we see? Proposal,

Only those properties of a single atom can be measured which can be correlated (with finite probability) (by various experimental arrangements) with an unlimited no. of atoms.

(I.e., the photographic spot is “real” because it can be enlarged & projected on screens, or affect large vats of

chemicals, or big brains, etc., etc.—it can be made to affect ever increasing sizes of things—it can determine whether a train goes from N.Y. to Chic.—or an atom bomb explodes—etc.) (Feynman, 1946b).

More recently, Feynman (1980b) expressed these views in more vivid language:

In other words, you tell me how much matter you want to get screwed up by correlating with something: you measure an electron, you turn a light green or red; not good enough for you to turn red or green, then you let the light turn an atomic bomb off or on . . . . You give me any value no matter how large but not infinite, then I can define what it means to measure. So instead of putting the thing into the mind, or psychology, I put it into a number (I tried to take the idea of a mathematical limit in which the order of limits is reversed). There is no absolute definition of measurement, but you tell me how accurate you want to be and I can show you that this thing would be measurable, and in practice the accuracy is fantastic for a small amount of excess matter getting screwed; once you get past a light bulb the rest of the correlations converge rapidly.

While working on his thesis Feynman also realized that the answers to problems in statistical mechanics could be formulated in terms of the same kind of path integrals except that the exponents were real. He derived that result from the differential equation for the density operator  $\rho = e^{-\beta H}$ ,

$$-\frac{\partial \rho}{\partial \beta} = H\rho, \quad (3.13)$$

but it seemed to him that there must be another way “that was very beautiful, if only [he] could find it, by which one writes quantum mechanics directly in terms of path integrals without going to the Schrödinger equation and then one goes directly across to statistical mechanics” (Feynman, 1980b).

As Feynman (1980b) recounts,

There I studied the question what do you mean by equilibrium. What do I have to do to a physical system to get it to equilibrium? So I would put the effective perturbations and couplings on my path integral as a dynamic object, and ask how does it transform into the correct answer for statistical results, hoping to do that in a fundamental way without ever descending, if I might put it that way, to the Schrödinger equation. The reason in my philosophy not to descend to the Schrödinger equation and to do as much of the physics as I could without doing that, is that I really believed at that time, in 1941–42, that this back action, this Wheeler-Feynman thing, was really a forward step. That's why I was doing everything. That's why I found everything. I wanted to get the quantum mechanics of that, and that was in the form of a path integral; it had no Hamiltonian. So the general subject was how can we describe all quantum mechanics, all of physics indeed, when there is a principle of least action but not a Hamiltonian. How does one get statistical mechanics if there is an action, but no Hamiltonian . . . .

It should, however, be stressed that Feynman was not trying to unify all of physics. Feynman conceived of physics even then as many closely interrelated pieces: there were problems all about. The only things that he really “knew” were the algorithms to compute “something” and “that's what physics knowledge really is” (Feynman, 1980b). For Feynman the complete accurate statement of an algorithm is the theory. Paths integrals represented a powerful algorithm for doing quantum mechanics, statistical mechanics, and questions in the theory of measurements. The power—and great value—of the method lay in the fact that it allowed one to separate the system into pieces and “integrate out parts of it,” something that was impossible to do with ordinary quantum mechanics stated in its differential form.

Already in his thesis Feynman had posed the following question: Consider the interaction of a harmonic oscillator of mass  $m$ , frequency  $\omega$ , coupled to two systems,  $A$  and  $B$ , described by Lagrangians  $L_y$  and  $L_z$ , so that the total system is described by an action

$$S = \int dt \left[ L_y + L_z + \left( \frac{m\dot{x}^2}{2} - \frac{m\omega^2 x^2}{2} \right) + (I_y + I_z)x \right]. \quad (3.14)$$

Is it possible to find an action  $\mathcal{A}$ , a functional of  $y(t)$  and  $z(t)$  only, such that, as far as the motions of the systems  $A$  and  $B$  are concerned [i.e., for variations of  $y(t)$  and  $z(t)$ ], the action  $\mathcal{A}$  is a minimum? The answer is yes, but with a specific proviso.

On the assumption that  $I_y = I_y(y(t), t)$  and similarly  $I_z = I_z(z(t), t)$ , the equation of motion for  $x(t)$ ,

$$\ddot{x}(t) + m\omega^2 x(t) = [I_y(t) + I_z(t)] = \gamma(t), \quad (3.15)$$

can be integrated. Feynman (1942) obtained the result that only if the specifications of  $x(t)$  are in terms of  $x(0)$  and  $x(T)$ , i.e., in terms of initial and final positions (rather than initial position and velocity), does an  $\mathcal{A}$  exist, e.g.,

$$\begin{aligned} \mathcal{A} = & \int_{-\infty}^{+\infty} dt (L_y + L_z) \\ & + \frac{1}{2m\omega} \int_{-\infty}^{\infty} \int_{-\infty}^t \sin\omega(t-s)\gamma(t)\gamma(s) ds dt. \end{aligned} \quad (3.16)$$

This is where matters stood in the spring of 1942 when Feynman wrote up his thesis at the strong urging of Wheeler. Wheeler had written to Feynman from Chicago (where he was working with Fermi and Wigner on the first atomic pile) that he felt he “had done more than enough for a thesis” and urged him “very strongly to write up what you have in the remaining few weeks before you get into the situation in which I now find myself”



(Wheeler, 1942). The completion of the dissertation terminated Feynman's discipleship with Wheeler. Wheeler had deeply influenced Feynman. They had discussed "many, many" physics problems together (Feynman, 1980b). Wheeler had helped develop Feynman's "geometrical" way of thinking. When Wheeler explains things, he always makes use of pictures and diagrams. Wheeler says of himself: "I think geometrically rather than in words. I think in term of pictures" (Wheeler, 1981). From Wheeler Feynman also learned to think in an abstract way. As Feynman puts it, "His grandiose views were useful. Everything could be done this way. Everything could be looked at that way. I learned physics could be looked at from many different ways; each one makes an axiom system and they are all different. They start from the other guy's theorem as the axiom for the other. Wheeler was important" (Feynman, 1980b).

#### IV. LOS ALAMOS AND GOING TO CORNELL

##### A. The war years

Early in 1942 Feynman became a member of the group working with Robert Wilson on the electromagnetic separation of  $^{235}\text{U}$  and  $^{238}\text{U}$  using the "isotron," a device that accelerated beams of ionized uranium and tried to separate the isotopes by bunching them, by the application of a high-frequency voltage to a set of grids part-way down the linear tube (Hewlett and Anderson, 1962, p. 59). Feynman had joined Wilson's group before he had completed his dissertation. He thereafter stopped working on it. After a time he asked for some weeks off to write up his ideas so that he would not forget them. While doing that he saw "a way to solve a problem that was holding [him] up, and Wheeler (1942) [then] suggested [he] quickly write it all up and finish getting his degree" (Feynman, 1985a). He then became absorbed in the problems of making an atomic bomb. He was well prepared for the task. He had taken Wheeler's course on nuclear physics and had edited a lucid, detailed set of notes based on that course (Wheeler, 1940). He had learned a great deal about the properties of materials from Wigner's "very good course" (Feynman, 1980b) on solid-state physics. And to prepare himself for the general examinations for the Ph.D. in the spring of 1940, he had reviewed all of physics and had written a notebook entitled "Things I don't know" (Feynman, 1940).

Early in 1943 Feynman left for Albuquerque; he was one of the first people to arrive at Los Alamos. He had been invited by Oppenheimer, who personally arranged for the transfer of Feynman's wife, who was ill with lymphatic tuberculosis, from a hospital near Princeton to one in Albuquerque (Feynman, 1976, p. 13).

Feynman has written about his experiences at Los Alamos (Feynman, 1976, 1980a, 1985b). From both his ac-

count and those of others, it is clear that he was one of the most versatile, imaginative, ingenious, and energetic members of that community of outstanding scientists.<sup>16</sup> Feynman came to Los Alamos as a regular staff member and was quickly recognized by Bethe and Oppenheimer as one of the most valuable individuals of the theoretical division.

##### Bethe recalls that Feynman

... was very lively from the beginning, ... I realized very quickly that he was something phenomenal. The first thing he did since we had to integrate differential equations, and at that time only had hand computers, was to find an efficient method of integrating third-order differential equations numerically. It was very, very impressive. Then, within a month, we cooked up a formula for calculating the efficiency of a nuclear weapon. It is named the Bethe-Feynman formula, and it is still used. I thought Feynman perhaps the most ingenious man in the whole division, so we worked a great deal together [Bethe in Bernstein (1979), p. 61].

As early as November 1943, Oppenheimer wrote R. Birge, the chairman of the Department of Physics at Berkeley:

As you know, we have quite a number of physicists here, and I have run into a few who are young and whose qualities I had not known before. Of these there is one who is in every way so outstanding and so clearly recognized as such, that I think it appropriate to call his name to your attention, with the urgent request that you consider him for a position in the department at the earliest time that is possible. You may remember the name because he once applied for a fellowship in Berkeley: it is Richard Feynman. He is by all odds the most brilliant young physicist here, and everyone knows this. He is a man of thoroughly engaging character and personality, extremely clear, extremely normal in all respects, and an excellent teacher with a warm feeling for physics in all its aspects. He has the best possible relations both with the theoretical people, of whom he is one, and with the experimental people, with whom he works in very close harmony.

The reason for telling you about him now is that his excellence is so well known, both at Princeton where he worked before he came here, and to a not inconsiderable number of "big shots" on this project, that he has already been offered a position for the post war period, and will most certainly be offered others. I feel that he would be a great strength for our department, tending to tie together its teaching, its research and its experimental and theoretical aspects. I may give you two quotations from men with whom he has worked. Bethe has said that he would rather lose any two other men than Feynman from his present job, and Wigner said, "He is a second Dirac, only this time human" (Smith and Weiner, 1980, pp. 268-269).

Feynman became a group leader in the Theoretical

<sup>16</sup>See, for example, Groueff (1967), Hawkins (1983).

Division under Bethe and worked on most aspects of the design and properties of the bombs.<sup>17</sup> He was sent to Oak Ridge to help ensure the safety of the isotope separation plants there,<sup>18</sup> and during the final phase of the bomb project at Los Alamos he was put in charge of computing, one of the most critical sections of the entire enterprise. Because he always explained to the members of his group the problems they were working on, even at the risk of violating security regulations—his deep respect for human rationality—he obtained from them in return a dedication that resulted in remarkable productivity (Welton, 1983). His versatility is legendary. His genius at lock-picking, repairing Marchant and Monroe calculators, assembling IBM machines, solving intricate puzzles<sup>19</sup> and difficult physics problems, suggesting novel calculational approaches, explaining theory to experimenters and experiments to theoreticians earned him the admiration of everyone with whom he came in contact.

Feynman's love for solving problems—his father's nurturing brought to full bloom—is quintessentially Feynman: part of it is a passionate need to “undo” what is “secret,”<sup>20</sup> to demystify, part of it is a need to constantly prove to *himself* that he is as good as anyone else, part

of it is a fiercely competitive nature which converts challenges into creative opportunities.

It was at Los Alamos that Feynman first met Hans Bethe. Bethe's unerring physical intuition, his awesome analytical powers, his sagacity, stamina, and erudition, his unaffected, straightforward demeanor, his “unflappability,” his forthright collegiality, and above all his integrity impressed Feynman deeply. Bethe's personality and his sense of humor were such that Feynman got along exceedingly well with him. He came “to love this man” (Feynman, 1980b).

Stephane Groueff, in his book on the Manhattan Project, has vividly described Feynman and Bethe's interactions at Los Alamos:

Richard Feynman's voice could be heard from the far end of the corridor: “No, no, you're crazy!” His colleagues in the Los Alamos Theoretical Division looked up from their computers and exchanged knowing smiles. “There they go again!” one said. “The Battleship and the Mosquito Boat!”

The “Battleship” was the division leader, Hans Bethe, a tall, heavy-set German who was recognized as a sort of genius in theoretical physics. At the moment he was having one his frequent discussions with Dick Feynman, the “Mosquito Boat,” who, from the moment he started talking physics, became completely oblivious of where he was and to whom he was talking. The imperturbable and meticulous Bethe solved problems by facing them squarely, analyzing them quietly, and then plowing straight through them. He pushed obstacles aside like a battleship moving through the water.

Feynman, on the other hand, would interrupt impatiently at nearly every sentence, either to shout his admiration or to express disagreements by irreverent remarks like “No, you're crazy!” or “That's nuts!” At each interruption Bethe would stop, then quietly and patiently explain why he was right. Feynman would calm down for a few minutes, only to jump up wildly again with “That's impossible, you're mad” and again Bethe could calmly prove it was not so (Groueff, 1967, p. 202).

“Bethe had a characteristic which I learned,” Feynman recalls, “which is to calculate numbers. If you have a problem, the real test of everything—you can't leave [it] alone—you've got to get the numbers out; if you don't get down to earth with it, it really isn't much. So his perpetual attitude [is] to use the theory—to see how it really works is to really use it” (Feynman, 1980b).

Feynman wistfully adds: “What I wasn't able to learn is his personality. He is able to write page after page, quietly. Everything he presents is organized.” Moreover, “he [Bethe] doesn't say something wrong and then get it right,” which is how Feynman sees himself working. And to prove his point Feynman quotes the Los Alamos aphorism “If Feynman says it three times it is right” (Feynman, 1980b). The fact of the matter is, however, that on almost any subject Feynman does get it right and usually the first time around.

Feynman's characteristic forthrightness was already in evidence then. His own description of his first encounters with Niels Bohr is revealing (Feynman, 1980a, pp.

<sup>17</sup>The group was known as T4. Its original members were Julius Ashkin, Frederick Reines, and Dick Ehrlich. Theodore Welton joined it in the early spring of 1944. For some of the problems the group worked on, see Welton (1983), Groueff (1967), p. 212, and Hawkins (1983).

<sup>18</sup>The question arose whether the gas diffusion plant for separating nuclear isotopes could lead to an accumulation of <sup>235</sup>U and cause a nuclear explosion. Compare Feynman's (1980) account and the one given by Teller in Blumberg and Owens (1976), p. 457.

<sup>19</sup>Feynman's passion for solving puzzles merits comment. Welton (1983) observes

Once presented with a clearly formulated physical paradox, mathematical results, card trick, or whatever, [Feynman] would not sleep until he had the solution. Shortly after I had arrived [at Los Alamos] I presented Dick with a problem (later immortalized in the *Feynman Lectures*, Vol. II, section 17.4). I had gotten it from a friend at NRL and had immediately solved it. I stated the problem and Dick asked if I had solved it. I said yes, but (truthfully and a bit strangely) the answer had slipped away. He promptly set to work on it, with me steadily demolishing his attempted solutions but still not remembering my own solution. We parted to get some sleep (I thought), but the next morning Dick showed up at the office a bit the worse for wear but triumphant. This sort of thing happened over and over again with important matters rather than trivia.

One facet of Welton's story should be noted: After Welton had told Feynman that he had solved the puzzle (even though he had forgotten the answer), Feynman never doubted it—he trusted his friend.

<sup>20</sup>“Now, one of my diseases, one of my things in life, is that anything that is secret I try to undo.” Feynman (1976), p. 19.

129–130). Bohr had escaped from Denmark to Sweden in September 1943. After a brief stay in London he received a Rockefeller Foundation grant for a presumed stay at the Institute for Advanced Study, but with his son Aage, he went to Los Alamos to work on the bomb.

Nicholas Baker's arrival at Los Alamos created quite a stir because "Even to the big shots, Bohr was a great God" (Feynman, 1980a, p. 129). Nicholas Baker was the name Bohr had assumed for security reasons, and he was affectionately known as Uncle Nick. Bohr had not been satisfied with his first conference with members of the theoretical division, at which the problems of the bomb were discussed. Before the second conference Bohr asked to see Feynman. When they met Bohr indicated that his son, Aage, and he had been thinking of ways of making the bomb more efficient. He outlined his idea. After listening to him, Feynman immediately told Bohr why it would not work. Bohr then suggested a different approach, which Feynman once again found impractical. Feynman comments,

I was always *dumb* about one thing. I never knew who I was talking to. I was always worried about the physics. If the idea looked lousy, I said it looked lousy. If it looked good, I said it looked good . . . I have always lived that way (Feynman, 1976, p. 28).

Feynman's discussion with Bohr went on for quite a while and when it was finished Bohr said "I guess we can call in the big shots now." At that point Bohr assembled the leading members of the theoretical division and had a discussion with them. Aage Bohr later explained to Feynman what had transpired. After his first conference, his father had told him that Feynman had been the only person at the meeting who was not afraid of him and who had been willing to say that an idea of his was "crazy." "So," said Bohr, "next time when we want to discuss ideas, we are not going to do it with these [big shots] . . . who say everything is yes, yes Dr. Bohr. Get [Feynman] and we'll talk with him first." (Feynman, 1976, p. 29).

In his reminiscences of Los Alamos Feynman also tells of the influence of Von Neumann on him.

Then there was Von Neumann, the great mathematician. We used to go for walks on Sunday. We'd walk in the canyons, and we'd often walk with Bethe, and Von Neumann, and Baker. It was a great pleasure. And Von Neumann gave me an interesting idea; that you don't have to be responsible for the world that you're in. So I have developed a very powerful sense of social irresponsibility as a result of Von Neumann's advice. It's made me a very happy man ever since. But it was Von Neumann who put the seed in that grew into my active irresponsibility<sup>21</sup> (Feynman, 1976, p. 28).

Welton has adumbrated Feynman's interactions with his peers at Los Alamos:

We all saw him diplomatically, forcefully, usually with humor (gentle or not, as needed) dissuade a respected colleague from some unwise course. We all saw him forcefully rebuke a colleague less favored by his respect, frequently with definitely ungentle humor. Only a fool would have subjected himself twice to such an experience (Welton, 1983).

The community's recognition of Feynman's talents can be gauged by the offers he received while at Los Alamos. As indicated by the previously quoted letter of Oppenheimer to Birge recommending an appointment for Feynman at Berkeley, Feynman had already received an offer for "a position for the post war period" at Cornell in November 1943. Birge, the very formal and very conservative chairman of the Physics Department at Berkeley, was unwilling to make a commitment that far in advance. Oppenheimer expressed his disappointment to Birge in May of 1944 and in his letter gave the following assessment:

As for Feynman himself, I perhaps presumed too much on the excellence of his reputation among those to whom he is known. I know that Brode, McMillan, and Alvarez are all enthusiastic about him, and it is small wonder. He is not only an extremely brilliant theorist, but a man of the greatest robustness, responsibility, and warmth, a brilliant and a lucid teacher, and an untiring worker. He would come to the teaching of physics with both a rare talent and a rare enthusiasm. We have entrusted him here with the giving of a course for the staff of our laboratory. He is one of the most responsible men I have ever met. He does not regard himself as a privileged artist but as one of a group of hard working men for whom the development of physical science is an obligation, and the exposition both an obligation and a pleasure. He spends much of his time in the laboratories and is always closely associated with the experimental phases of the work. He was associated with Robert Wilson in the Princeton project, and Wilson attributes a great part of the success of that project to his help. We regard him as invaluable here; he has been given a responsibility and his work carries a weight far beyond his years. In fact he is just such a man as we have long needed in Berkeley to contribute to the unity of the department and to give it technical strength where it has been lacking in the past (Smith and Weiner, 1980, pp. 276–277).

## B. Coming to Cornell

Feynman had accepted Bethe's offer of a three-year appointment as an assistant professor at Cornell. This

<sup>21</sup>The development was gradual. After he came to Cornell in the fall of 1945, Feynman was a member of the Association of Scientists of Cornell University, Rockefeller Hall, and gave public lectures on various aspects of the problems of atomic power and atomic weapons. In April 1946, he gave the first radio talk on these issues in a series called "The Scientists Speak" (Feynman, 1946c). His "social irresponsibility" is also highly selective. I was struck, while studying his correspondence in the CIT Archives, by the fact that often Feynman answers letter and inquiries to him very briefly. The one consistent exception is the letters he writes to students asking him for advice, information, or suggestions. These are lengthy, thoughtful, and helpful.

meant that he was formally on leave from Cornell University, with Los Alamos paying  $\frac{11}{9}$  of his annual salary of \$3000, as set by his Cornell contract. In July of 1945, at Oppenheimer's insistence, Feynman was finally offered an assistant professorship at Berkeley at the then considerable salary of \$3900 per year (M.E. Deutsch, 1945). Birge wrote him that "During the period that the department was being built up by the addition of men like Lawrence, Brode, Oppenheimer, Jenkins, and White, and more recently by MacMillan and Alvarez, no one to whom we made an offer ever refused it. If you come to Berkeley, I am certain you will never regret the decision" (Birge, 1945). But Feynman did refuse (Feynman, 1945a, 1945b). His affection, respect, and esteem for Bethe were the decisive factors. At Bethe's insistence, Cornell had immediately countered Berkeley's offer and set his "potential" salary at \$4000 per annum (Gibbs, 1945a, 1945b). In recommending this increase of salary Bethe indicated that his already high opinion of Feynman had further increased over the course of the year. "[Feynman] has been absolutely invaluable to this project. You can ask him to do anything at all from the most complicated theoretical calculations to the organization of a group of men to do machine computations. Everybody goes to him to have things explained, and I think he is one of the best teachers our department ever had" (Bethe, 1945).

In the fall of 1945, Feynman went to Cornell eager to assume his new professorial duties. He was one of the first persons to leave Los Alamos. The war's end in August 1945 had put great pressure on universities to accommodate the vast numbers of students who were expected to start or resume their studies. A year later, in the fall of 1946, H. D. Smyth, the chairman of the Physics Department at Princeton, wrote Feynman that the University and the Institute for Advanced Study would like to make him an offer "of a permanent position at a substantial salary" (Smyth, 1946), whereby he would spend half of every academic year in the Department of Physics at the University and the other half as a member of the Institute, free of any teaching duty. Again Feynman decided to stay at Cornell. The Princeton offer resulted in his being promoted to an associate professor. An offer of an associate professorship at UCLA was also declined. He did consider very seriously invitations to visit Berkeley—one for the academic year 1947–1948 and one for the following year—but Oppenheimer's acceptance of the directorship of the Institute for Advanced Study in the Spring of 1947 convinced him to stay at Cornell.

At the time Feynman did not think that he merited these offers. Although he was giving interesting and stimulating graduate courses—in mathematical physics and in electricity and magnetism—he felt that his research was not going anywhere. He was depressed by the deaths of his wife and of his father and began to think that he was "burned out" (Feynman, 1966b), that this was the end, and that he would not accomplish anything. When he received the offer from Princeton, his reaction was that "they were absolutely crazy" (Feynman, 1966b).

It was during this period that Feynman accepted Wigner's invitation to comment on the paper Dirac was presenting to the "Nuclear Physics" session of the Princeton Bicentennial conference on 24 September 1946 (Wigner, 1946, 1947; Osgood, 1951). Dirac had given Feynman a handwritten copy of his paper and he had studied it (Dirac, 1946). In his comments Feynman was rather critical of Dirac's work, believing him to be going "on the wrong track" by working more and more with Hamiltonians and not coming to the central problems that quantum electrodynamics was facing. Since Feynman did not feel very confident, he made many more than his normal quota of jokes during his comments and Weisskopf criticized him afterwards for what he considered a poor presentation. Bohr, however, came to Feynman's defense and agreed with him "that we have some important problems here to discuss" (Feynman, 1966b).

It should be pointed out that his close associates at the time—Philip Morrison, with whom he shared an office, and Hans Bethe, with whom he had frequent discussions—were unaware of his depression. Bethe explains "Feynman depressed is just a little more cheerful than any other person when he is exuberant" (Bethe, 1980; Morrison, 1984). On the other hand, to Welton, who "was entranced as always by the flow of ideas" when he met Feynman during that time at Physical Society meetings, "it was clear that his mind was not really where it properly belonged" (Welton, 1983). In the spring of 1947 Feynman revealed to Bob Wilson, who had just come to Cornell as the director of the newly founded Newman Laboratory for Nuclear Studies, his concerns that Cornell had made a "bad bet" with him. Wilson chided Feynman: "when we hire someone we take a risk and it is *our* risk." Feynman asserts that talking to Wilson "turned him around" (Feynman, 1966b).

### C. Researches: 1946

When Feynman came to Cornell, he resumed the investigations that the war had interrupted.

Although at Los Alamos he had worked intermittently on the problems of QED and statistical mechanics, primarily on the bus ride to and from Albuquerque to visit his wife, he did not discuss these problems with his colleagues.<sup>22</sup> Moreover, less and less time was spent on these

<sup>22</sup>Feynman's wife was ill with tuberculosis and was hospitalized in Albuquerque. On weekends Feynman would visit her. Nonclassified work was the only thing he could do on the bus rides to and from the hospital. She died just before Trinity. Welton (1983) recalls that when he arrived at Los Alamos in 1944, Feynman met him at the train station.

After giving me a thorough briefing on the work of the project and of his group [T4], the talk degenerated to a description of our interest in nonmilitary physics . . . He showed me how . . . his later-to-be-famous formulation in terms of a summation over all space-time trajectories of the system . . . worked by a simple illustration.

matters as the pace at Los Alamos intensified in late 1944 and 1945. The initial phase of his researches at Cornell was devoted to reconstructing and reevaluating the work he had carried out during the last stages of his dissertation and while at Los Alamos. One of the problems addressed was to understand the approach to thermodynamic equilibrium of a system whose charged constituents interact via delayed interactions, or via half advanced plus half retarded electromagnetic interactions. Among Feynman's papers at the CIT archives are extensive notes of his calculations to prove the adiabatic theorem to various orders in perturbation theory (Feynman, 1946b). These notes are interesting because in them Feynman resorts to diagrammatic mnemonics to keep track of the terms he encounters (Fig. 7). However, the results were ambiguous, and Feynman was not satisfied with them. The research was motivated by the belief that a system interacting via delayed interactions would reach equilibrium at some temperature; and Feynman sought a specification for the probability of a given motion of the system at a fi-

nite temperature directly in terms of the action that described the dynamics of the system.

Another problem Feynman (1946d) worked on was how to describe in his integral-over-paths formulation of quantum mechanics—his "track theory"—a spin- $\frac{1}{2}$  particle, and more particularly a relativistic spin- $\frac{1}{2}$  particle, i.e., a Dirac particle. Since the concept of the spin of a point-like particle is lacking in classical theory and does not enter in the classical action, it is not immediately obvious what kinds of paths should be contemplated and *a fortiori* the amplitudes that should be assigned to them so as to give rise to the Dirac equation. Feynman's research activities at the beginning of 1947 are described in a letter he wrote to Welton: "I am engaged now in a general program of study—I want to understand (not just in a mathematical way) the ideas of all branches to theor[etical] physics. As you know I am now struggling with the Dirac Equ." (Feynman, 1947a).

Feynman was able to give a "derivation" of the Dirac equation for a particle of mass  $m$  in a world consisting of

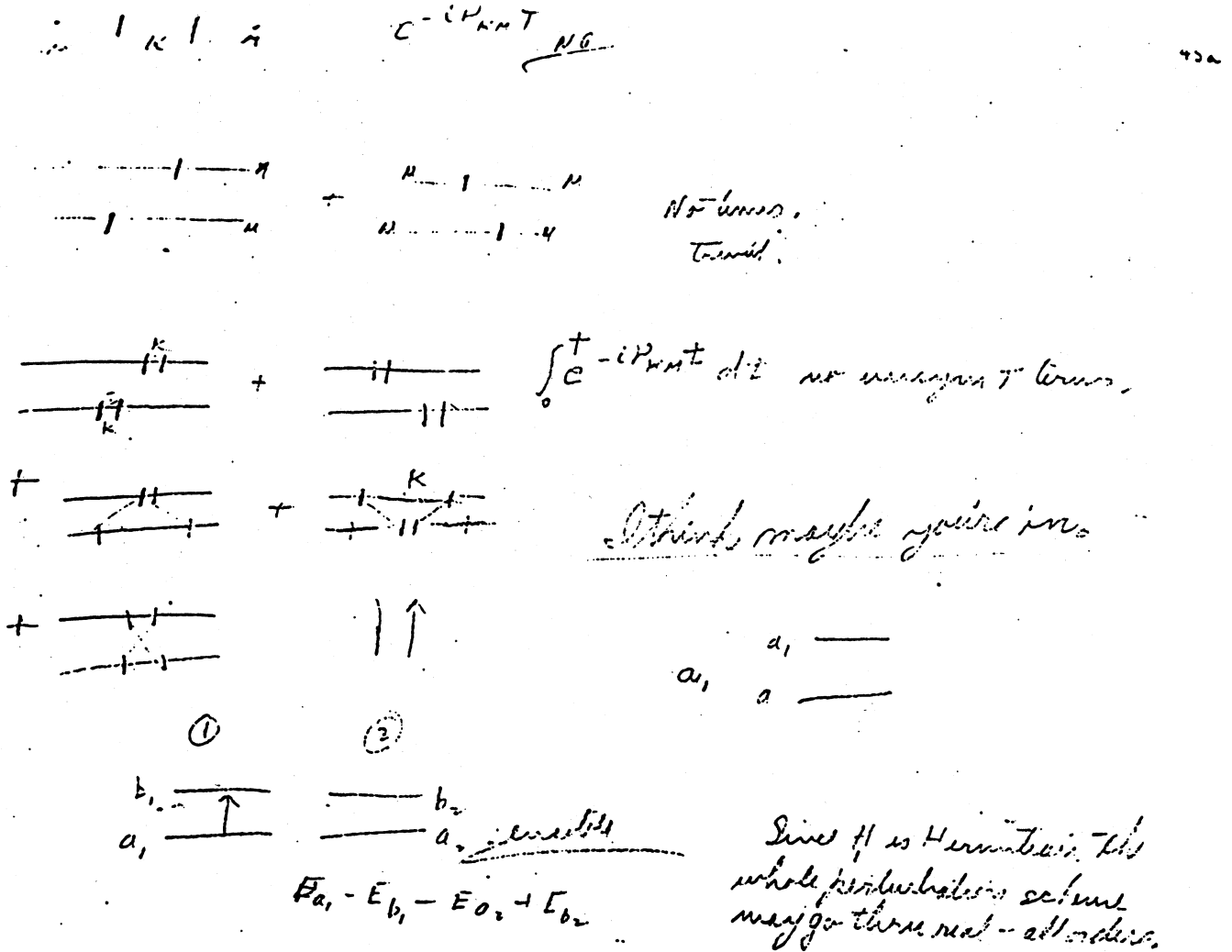

FIG. 7. Some of the diagrams in Feynman's 1946 notes on the adiabatic theorem (Feynman, 1946b).

New Variables

$$u = t + x \quad t = \frac{1}{2}(u + v)$$

$$v = t - x \quad x = \frac{1}{2}(u - v)$$

$$\frac{\partial}{\partial t} = \frac{\partial}{\partial u} + \frac{\partial}{\partial v} \quad \frac{\partial}{\partial x} = \frac{\partial}{\partial u} - \frac{\partial}{\partial v}$$

$$\psi_3 + \psi_1 = \psi_R \quad \psi_3 - \psi_1 = \psi_L$$

$$-\frac{\hbar}{i} \frac{\partial}{\partial u} \psi_R = \mathcal{E} \psi_R - \mu \psi_L$$

$$2M = \mathcal{E} - A$$

$$-\frac{\hbar}{i} \frac{\partial}{\partial v} \psi_L = 2N \psi_R - \mu \psi_L$$

$$2N = \mathcal{E} + A$$

$$\mathcal{E} = 2\left(\frac{\partial N}{\partial u} - \frac{\partial M}{\partial v}\right)$$

$$i\left(\frac{\partial}{\partial u} + M\right) \psi_R = -\frac{\mu}{2} \psi_L$$

$$i\left(\frac{\partial}{\partial v} - N\right) \psi_L = -\frac{\mu}{2} \psi_R$$

Free particles: let  $\frac{\partial u}{\partial x} = a$ ,  $\frac{\partial v}{\partial x} = b$ ,  $\frac{\partial \psi_R}{\partial a} = i \psi_L$ ,  $\frac{\partial \psi_L}{\partial b} = i \psi_R$

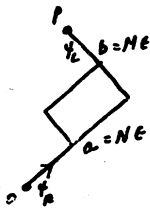

Solve by path counting, starting right from 0, how many get L at P?

$$\psi_L(P) = i\mathcal{E} + (i\mathcal{E})^3 \cdot MN + (i\mathcal{E})^5 \cdot \frac{M^2 N^2}{2! 2!} \dots$$

$$= i\mathcal{E} \left(1 - ab + \frac{a^2 b^2}{2! 2!} - \dots\right) = i\mathcal{E} J_0(2\sqrt{ab}) = i\mathcal{E} J_0(\sqrt{v^2 - x^2})$$

$$\psi_R(P) = (i\mathcal{E})^2 N + (i\mathcal{E})^4 \frac{M^2}{2!} + (i\mathcal{E})^6 \frac{N^3}{3!} \frac{M^2}{2!} + \dots$$

$$= \mathcal{E} - \mathcal{E} \left(a - \frac{a^2}{2!} b + \frac{a^3}{3!} \frac{b^2}{2!} - \dots\right) = -\mathcal{E} \frac{\partial}{\partial b} \left(ab - \frac{a^2 b^2}{2!} + \frac{a^3 b^3}{3!} - \dots\right)$$

$$= +\mathcal{E} \frac{\partial}{\partial b} J_0(2\sqrt{ab})$$

formally comes from derivative of  $J_0$  at  $b=0$  physically from no turn path!

$$= -\mathcal{E} \sqrt{\frac{a}{b}} J_1(2\sqrt{ab}) + \mathcal{E} \delta(b)$$

To check:  $\frac{\partial \psi_L}{\partial b} = i \psi_R$  is automatic.  $\frac{\partial \psi_R}{\partial a} = -\mathcal{E} \frac{\partial}{\partial a} \left[\sqrt{\frac{a}{b}} J_1(2\sqrt{ab})\right] = -\frac{\mathcal{E}}{2b} \frac{\partial}{\partial a} [2\sqrt{ab} J_1(2\sqrt{ab})]$

The factor  $\mathcal{E}$  just becomes  $\frac{dx}{2}$  on integrating green's function.  $= -\frac{\mathcal{E}}{2b} \frac{\partial}{\partial a} \left[\frac{b}{a} \cdot 2\sqrt{ab} J_1(2\sqrt{ab})\right] = -\mathcal{E} J_0(2\sqrt{ab}) = i \psi_L$  at region.

Hence if  $\psi$  at  $t = t_1, x = x_1$ ,  $\psi$  is  $\psi_R(x_1, t_1)$  and  $\psi_L$  is zero, then at  $t_2, x_2$

get  $(x=1)$   $\psi_L(x_2, t_2) = i \int_{\text{inside light cone}} J_0(\sqrt{(t_2-t_1)^2 - (x_2-x_1)^2}) \psi_R(x_1, t_1) \frac{dx_1}{2}$



$$\psi_R(x_2, t_2) = - \int \frac{(t_2 - t_1 + x_2 - x_1)}{\sqrt{\dots}} J_1(\sqrt{\dots}) \psi_R(x_1, t_1) \frac{dx_1}{2} + \int \dots \psi_R(x_1, t_1) dx_1$$

or in case both  $\psi_L$  and  $\psi_R$  are not zero initially obtain the complete green's formula:  $(0 \leq v \leq \hbar)$ .

FIG. 8. (a) Diagrams from Feynman's notes on his path integral derivation of the Dirac equation in one dimension (Feynman, 1946d). (b) From Feynman's notes on the "Geometry of Dirac's Equation in 1 Dimension" (Feynman, 1946d).

(a)

$$\psi_L(x_2, t_2) = \int \psi_L(x_1, t_1) dx_1 \left[ \delta(t_2 - t_1 + x_2 - x_1) - \frac{t_2 - t_1 - x_2 + x_1}{2\sqrt{1-v^2}} J_1(\sqrt{1-v^2}) \right]$$

$$+ i \int \psi_R(x_1, t_1) dx_1 J_0(\sqrt{1-v^2})$$

$$\psi_R(x_2, t_2) = \int \psi_R(x_1, t_1) dx_1 \left[ \delta(t_2 - t_1 - x_2 + x_1) - \frac{t_2 - t_1 + x_2 - x_1}{2\sqrt{1-v^2}} J_1(\sqrt{1-v^2}) \right]$$

$$+ i \int \psi_L(x_1, t_1) dx_1 J_0(\sqrt{1-v^2})$$

$v=1$

$$\sqrt{1-v^2} = \sqrt{(t_2 - t_1)^2 - (x_2 - x_1)^2}$$

Integrals only over region in which  $\sqrt{1-v^2}$  is real.  $\Rightarrow t_2 > t_1$

Geometry of Dirac Eq. 1 dimension

(b)

Prob = Sgu. of Sum of contrib each path  
 Paths zig zag at light velocity.  
 Contributs  $i\epsilon$  factor for each reversal  
 and factor  $e^{\frac{i}{\hbar} \int A dx + \phi dt}$  if fields are present.



$v = x/t$	cont. Paths	$i\epsilon$	Relative 1
$u = x-t$	.. 3	$(i\epsilon)^2 NM$	- ab
	5	$(i\epsilon)^5 \frac{M(N-1)}{2} \frac{M(N-1)}{2}$	$+ \frac{a^2 b^2}{2!^2}$
		...	$- \frac{a^2 b^3}{3!^2} \dots$

$$\therefore J_0(\sqrt{ab}) = J_0(\sqrt{v^2 t^2 - x^2}) + \delta(x^2 - x_0^2) + \delta(t+x)$$

D'Alembert Solution of  $\frac{\partial^2 \phi}{\partial t^2} - \frac{\partial^2 \phi}{\partial x^2} = \rho$

( $ab = m^2$  for many terms)

Interpretation

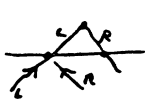

$$\psi_L(x, t) = \psi_L(x-\epsilon, t-\epsilon) + \psi_R(x-\epsilon, t-\epsilon) \cdot i\epsilon$$

$$\psi_R(x, t) = \psi_R(x+\epsilon, t-\epsilon) + \psi_L(x+\epsilon, t-\epsilon) \cdot i\epsilon$$

Most important paths have lots of left turns & right turns.  
 or turns occur about every unit (compton mass length) length  
 $\therefore$  oscillations at frequency about unit  
 $\therefore e^{i\epsilon}$   $\approx \frac{mc \text{ proper}}{\hbar} \text{ time}$

FIG. 8. (Continued).

one space and one time (Feynman, 1966a, p. 704). The particle is assumed to be able to travel in both the plus- and minus- $x$  direction, and to move with the speed of light. It starts at  $x=0$  at  $t=0$ , and ends at  $x$  at time  $t$  where  $|x| \leq t$ . The interval  $[0,t]$  is divided into a large number of  $n$  of small intervals of duration  $\epsilon$  so that

$$t = n\epsilon. \quad (4.1)$$

If one supposes that in the entire interval  $[0,t]$  the particle travels in the plus- $x$  direction  $n_1$  times, and in the minus- $x$  direction  $n_2$  times, then

$$n\epsilon = (n_1 + n_2)\epsilon = t, \quad (4.2a)$$

$$(n_1 - n_2)\epsilon = x \quad (4.2b)$$

(the speed of light has been taken for convenience to be  $c=1$ ). A typical path will consist of null segments (since it travels with velocity  $c$ ) meeting in sharp corners. The propagator to go from  $(0,0)$  to  $(t,x)$  is obtained by summing over all paths the expression  $\sum_R A(\Gamma, R)$ , where  $A(\Gamma, R)$  is the amplitude for the path  $\Gamma$ , with  $R$  corners. Feynman showed that one could derive the Dirac equation in one-space—one-time dimension if the amplitude for a path with  $R$  corners is taken to be  $(i m \epsilon)^R$ . (See Fig. 8.) Stated differently, each time the electron reverses spatial direction, it acquires a phase factor  $e^{i\pi/2}$ .

Feynman encountered difficulties in extending the idea "of loading each turn thru  $\theta$  by  $e^{i\theta/2}$ " (Feynman, 1947a), which worked in one space dimension to higher dimensions because in those situations the angles  $\theta$  are in different planes. He tried to use quaternions and "octonions" (quarternions representing Euclidean four-dimensional rotations) to represent wave functions, but he was not able to obtain a "natural" representation of the Dirac equation as an integral over paths.

Although these researches had given him many insights into the Dirac equation in 1, 2, 3, and 4 spatial dimensions, Feynman's paper on the "Space-Time Approach to Non-Relativistic Quantum Mechanics"—which he submitted in the summer of 1947 to the *Reviews of Modern Physics*—only dealt with spin "in a formal way." Feynman characterized his incorporation of spin and relativity into the formalism as "adding nothing to the understanding of these [Dirac and Klein-Gordon] equations," and he added the statement

There are other ways of obtaining the Dirac equation which offer some promise of giving a clearer physical interpretation to that important and beautiful equation" (Feynman, 1948c, p. 387).

The "other ways" to which Feynman was alluding were the ones he had outlined in his letter to Welton. He concluded that letter with some interesting philosophical remarks:

Now I would like to add a little hooley. The reason I am so slow is not that I do not know what the correct equations, in integral or differential forms, are (Dirac tells me), but rather that I would like to *understand* these equations from as many points of view as possible. So I do it in 1, 2, 3, & 4 dimensions with different assumptions etc. . . .

I find physics is a wonderful subject. We know so very much and then subsume it into so very few equations that we can say we know very little (except these equations—Eg., Dirac, Maxwell, Schrod.). Then we think we have *the* physical picture with which to interpret the equations. But there are so very few equations that I have found that many physical pictures can give the same equations. So I am spending my time in study—in seeing how many new viewpoints I can take of what is known.

Of course, the hope is that a slight modification of one of the pictures will straighten out some of the present troubles.

I dislike all this talk of others [of there] not being a picture possible, but we only need know how to go about calculating any phenomenon. True we only *need* calculate. But a picture is certainly a *convenience* & one is not doing anything wrong in making one up. It may prove to be entirely haywire while the equations are nearly right—yet for a while it helps. The power of mathematics is terrifying—and too many physicists finding they have correct equations without understanding them have been so terrified they give up trying to understand them. I want to go back & try to understand them. What do I mean by understanding? Nothing deep or accurate—just to be able to see some of the qualitative consequences of the equations by some method other than solving them in detail.

For example, I'm beginning to get a mild "understanding" of the place of Dirac's  $\alpha$  matrices, which were invented by him "to produce an equation of first order in the differential coefficient in the time," but by me in order "to keep track of the result of a succession of changes of coordinate system . . ."

Why should the fundamental laws of Nature be so that one cannot explain them to a high-school student—but only to a quite advanced graduate student in physics? And we claim they are simple! In what sense are they simple? Because we can write them in one line. But it takes 8 years of college education to understand the symbols. Is there any simple *ideas* in the laws? (Feynman, 1947a).

During the spring of 1947 Feynman started writing up the results of his dissertation for the article "Space-Time Approach to Non-Relativistic Quantum Mechanics," which he submitted to the *Reviews of Modern Physics* early in the fall of that year. The writing did not go well. Corben, with whom he spent part of the summer in Pittsburgh, recalls that

[Feynman] was articulate (as always) but had difficulty at first in putting his ideas down on paper. Along with Alfred Schild, who lived in the same house, we practically locked Dick in a room and told him to start writing. The first draft was poor, but after three weeks the . . . publication emerged (Corben, 1984).

In a letter to a graduate student who was trying to obtain a copy of his Ph.D. thesis Feynman (1949d) pointed out the main differences between the thesis and the RMP article:

In the thesis I was trying to generalize the idea [of using integral over paths as a quantization procedure] to apply to any action function at all—not just the integral of a



function of values [*sic*, should read velocities] and positions (see Section 12). All the ideas which appear in the Review article were written in such a form that if any generalization is possible, they can be readily translated (in particular the important equation 45). The thesis contains a somewhat more detailed analysis of the general relation of the invariance properties of the actional [action] functional and constants of the motion. Also the problems of elimination of intermediate harmonic oscillators is done more completely than is done in Section 13. The reason I did not publish everything in the thesis is this. I met with a difficulty. An arbitrary action functional  $S$  produces results which do not conserve probability; for example, the energy values come out complex.<sup>23</sup> I do not know what this means nor was I able to find that class of actional functionals which would be guaranteed to give real eigenvalues for the energies (Feynman, 1949d).

Important conceptual advances had also been made since 1942. There was now an unmistakable visual aspect to the formalism. Although no pictures appear in the paper, the text explicitly enjoins the reader to conceive of the amplitude  $(q_2 t_2 | q_1 t_1)$  for a particle to go from  $x_1$  at time  $t_1$  to  $x_2$  at  $t_2$  as receiving contributions from all the trajectories that can be drawn between  $x_1 t_1$  and  $x_2 t_2$  along which time increases monotonically. This amplitude  $(q_2 t_2 | q_1 t_1)$  is what Feynman will later call the propagator  $K(2,1)$ ; it is the total amplitude for the arrival of the particle at  $q_2$  at  $t_2$  if it was at  $q_1$  at  $t_1$  [see Eq. (3.12)]. In Feynman's notation the space-time point  $(q_2, t_2)$  is denoted by 2. Feynman himself believes "clarity came from writing up the RMP article." Although he had amplitudes before, the "pictures" only came at this stage. When doing path integrals he now visualized paths: "I could see the paths ... each path got an amplitude" (Feynman, 1980b).

Similarly, although propagators for finite time intervals are not explicitly introduced, it is clear that Feynman is conceiving problems in terms of their use. Thus in Section 8 of that article perturbation theory is presented in a fashion that makes evident that the higher-order terms

are most simply expressed in terms of finite time propagators. Implicit in the RMP article is a perturbation theory for the propagator

$$K(2,1) = \int \cdots \int \mathcal{D}(\text{path}) \exp \left[ \frac{i}{\hbar} \int L dt \right] \quad (4.3)$$

when the action is of the form

$$S = S_0 - \int_{t_0}^t U[x(t)] dt, \quad (4.4)$$

with  $U$  a perturbation, and  $S_0$  defining the "unperturbed" propagator

$$K_0(2,1) = \int \cdots \int \mathcal{D}(\text{path}) \exp \left[ \frac{i}{\hbar} S_0 \right]. \quad (4.5)$$

Expanding the exponential yields the familiar result

$$K(2,1) = K_0(2,1) - \frac{i}{\hbar} \int d\tau_3 K_0(2,3) U(3) K_0(3,1) + \cdots \quad (4.6)$$

[which is the equation following Eq. (44) in Feynman (1948c) stated in a different notation]. The steps by which the right-hand side of Eq. (4.6) are obtained were of great importance for the subsequent developments. The expansion of

$$\exp \left[ - \frac{i}{\hbar} \int_{t_0}^{t_2} U[x(t)] dt \right]$$

yields the following first-order term:

$$- \frac{i}{\hbar} \int \cdots \int \mathcal{D}(\text{path}) e^{(i/\hbar)S_0} \int_{t_1}^{t_2} U[x(t)] dt, \quad (4.7)$$

which is given meaning by the Feynman specification of a path  $x(t)$  by the value of  $x(t)$  at  $t_1, t_1 + \epsilon, t_1 + 2\epsilon, \dots, t_2$  and

$$\mathcal{D}(\text{path}) \rightarrow \frac{dx_1}{A} \cdots \frac{dx_N}{A}. \quad (4.8)$$

Thus Eq. (4.7) is to be understood as

$$- \frac{i}{\hbar} \int \cdots \int \frac{dx_1}{A} \cdots \frac{dx_l}{A} \frac{dx_{l+1}}{A} \cdots \frac{dx_N}{A} \exp \left[ \frac{i}{\hbar} \sum_{l+1}^N L(x_j, x_{j+1}) \epsilon \right] \epsilon \sum_l U(x_l) \exp \left[ \frac{i}{\hbar} \sum_1^l L(x_j, x_{j+1}) \epsilon \right]. \quad (4.9)$$

Fix  $x_l$ : Then the integrations over  $x_1$  to  $x_l$  can be performed, yielding  $K_0(l,1)$ . Similarly the integrations from  $l+1$  to  $N$  can be performed, and one is left with

$$- \frac{i}{\hbar} \int dx_l \sum_l \epsilon K_0(2,l) U(l) K_0(l,1),$$

<sup>23</sup>For example, the quantization procedure applied to the action

$$S = \int x(t)x(t+a) dt,$$

for which there is no canonical momentum nor a Hamiltonian, gives rise to negative probabilities and imaginary energies.

the first-order term in the right-hand side of Eq. (4.6). Attached to (4.6) is a visual picture, which represents the integral as obtaining contributions from all paths connecting first the space-time point 1 to  $l$  at  $l\epsilon$ , and then the paths connecting  $l$  to 2 (Fig. 9). The kernel  $K(2,1)$  solves the problem

$$\psi(2) = \int K(2,1) \psi(1) d^3(1). \quad (4.10)$$

In fact, the equivalence of the integral-over-path method to the standard version of quantum mechanics was demonstrated by showing that Eq. (4.10), with  $K$  defined

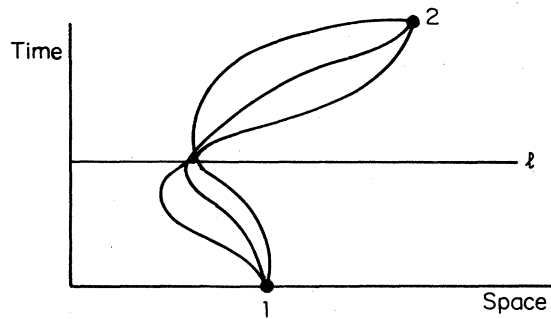

FIG. 9. The space-time representation of Eq. (4.7).

as an integral over paths, yielded the Schrödinger equation when 2 was infinitesimally close to 1. Thus the integral-over-path representation of Eq. (4.10) could also be looked upon as giving meaning to the expression

$$|\psi(t_2)\rangle = \exp \left[ \frac{i}{\hbar} \int_{t_1}^{t_2} H(t') dt' \right] |\psi(t_1)\rangle, \quad (4.11)$$

which is a *formal* solution of  $H|\psi\rangle = i\hbar\partial_t|\psi\rangle$  when the

exponential factor is properly interpreted. Feynman's calculus of ordered operators—which is closely linked to the meaning given to expressions like (4.11) by their integral-over-path formulation—was developed during the summer and fall of 1947 as a natural outgrowth of generalizing the results he obtained for nonrelativistic particles to the case when the particles are described by the Dirac equation.

## V. THE GENESIS OF THE THEORY

### A. Shelter Island and its aftermath

Feynman was one of the “young men” invited to the Shelter Island conference (Figs. 10 and 11). It was his first “pure” physics conference with “big men” (Feynman, 1966b). Some twenty years later he commented “There have been many conferences in the world since, but I've never felt any to be as important as this” (Feynman, 1966b). Shelter Island was indeed the stimulus that made him address once more the problems of quantum electrodynamics. But more precisely, it was Bethe who



FIG. 10. W. Lamb, A. Pais, R. Feynman, H. Feshbach, and J. Schwinger conferring during the Shelter Island conference. J. A. Wheeler is standing against the wall. Courtesy of AIP Niels Bohr Library.

got Feynman started working on these problems again. After Bethe had completed his famous train-ride calculation of the level shift, he called Feynman "excitedly" from Schenectady to tell him that he understood the Lamb shift (Feynman, 1966a, p. 705). When Bethe returned to Cornell in early July, he gave a lecture explaining his nonrelativistic calculation. He indicated that he had encountered a logarithmic divergence for the Lamb shift—because in this nonrelativistic theory the electron self-energy is linearly divergent—but he argued that in a relativistic calculation the Lamb shift would be finite, because the self-energy of an electron in hole theory is only logarithmically divergent.<sup>24</sup> In concluding his lecture, Bethe stressed that if there were a way of making electrodynamics finite with a relativistic cutoff procedure, it would then be much simpler to carry out a relativistic quantum field-theoretic calculation of the Lamb shift.

After Bethe's lecture, Feynman went up to him and told him, "I can do that for you. I'll bring it in for you tomorrow" (Feynman, 1966a, p. 705). How to introduce a relativistic invariant cutoff into the *Lagrangian* of classical electrodynamics was something Feynman knew how to do. Using his integral-over-path method, he could then quantize the theory (in terms of this altered but still invariant Lagrangian) without invoking either a Hamiltonian or equal time commutation rules that destroyed the manifest invariance. However, he did not know how to compute a self-energy, since in Wheeler-Feynman theory charged particles do not interact with themselves. In fact, the elimination of self-interactions had been the initial motivation for his approach.

When they met the next day, Bethe showed Feynman how the expression for the self-energy is derived, and Feynman tried to apply his cutoff method to it. But for some reason, working together at the blackboard, they found that Feynman's cutoff method did not yield a finite answer for the self-energy. (Incidentally, neither Feynman nor Bethe were ever able to discover where they had gone wrong.) However, Feynman never doubted that it would. And thus he got started on his epic researches.

Feynman (1966a, p. 705) has described the sequel to that encounter:

So, I went back to my room and worried about this thing and went around in circles trying to figure out what was wrong because I was sure physically everything had to come out finite. I couldn't understand how it came out infinite. I became more and more interested and finally realized I had to learn how to make a calculation. So, ultimately, I taught myself how to calculate the self-energy of an electron, working my patient way through the terrible confusion of those days of negative-energy states and holes and longitudinal contribution and so on . . . .

In retrospect, it was a good thing that, working with Bethe, the initial attempt at rendering the self-energy finite failed. It forced Feynman to learn the "practical" aspects of quantum electrodynamics and convinced him that the cutoff method he had proposed, "if carried out without making a mistake," was "all right;" it gave a finite answer for the self-energy and "nothing went wrong 706).

Feynman has outlined the genesis of his approach in

<sup>24</sup>Oppenheimer (1930) and Waller (1930) were the first to calculate the self-energy of a Dirac electron in the "one-particle" version of the theory in which all the negative-energy states are assumed empty. They found a linear divergence. [For a historical survey of the divergences in quantum field theory see Weinberg (1977).] In the spring of 1933, Bohr visited Berkeley and suggested to Carlson and Furry that the electron's self-energy be recomputed in hole theory, in which all the negative-energy states were assumed to be filled (Dirac, 1930). Carlson and Furry did this, but only computed the magnetic self-energy (coming from the  $\mathbf{j} \cdot \mathbf{A}$  term) and found a logarithmic divergence. Early in 1934, Pauli made the same suggestion to Weisskopf, who likewise carried out a calculation of the self-energy of the electron in hole theory and published his results (Weisskopf, 1934a). However, Weisskopf made an error in the calculation of the magnetic self-energy term, and had obtained a linearly divergent contribution for this term.

When Furry examined the paper and discovered Weisskopf's mistake, he went to Oppenheimer and asked him what to do. Oppenheimer told him "You can either publish or do the noble thing" (Furry, 1979). Furry did the noble thing and wrote Weisskopf. In his letter Furry (1934) related to Weisskopf

that the result of the electrostatic proper energy was new to us, as for some reason we had not previously realized the need of recalculating it. We are thoroughly convinced that your result is right, and think that it is of order  $\int dk/k$ . Furry then pointed out to Weisskopf that he had made a mistake in his calculation of the magnetic proper energy and informed him of his and Carlson's result for it,

$$E^D = \frac{mc}{(m^2c^2 + \mathbf{p}^2)^{1/2}} \left[ 1 - \frac{4}{3} \frac{\mathbf{p}^2}{m^2c^2} \right] \frac{e^2}{\hbar c} \int \frac{dk}{k} + \text{finite terms},$$

which he noted was "of the same order as your result for the electrostatic proper energy." Upon receiving Furry's letter, Weisskopf proceeded to publish an erratum to his previous paper in which he acknowledged Furry's contribution (Weisskopf, 1934b). He also wrote Furry to thank him (Weisskopf, 1934c).

The reduction in hole theory of the electron self-energy to a logarithmic divergence occurs because the presence of the electron in question perturbs the vacuum energy through the Pauli exclusion principle. Vacuum fluctuations having intermediate states identical to that of the original electron are excluded by the Pauli exclusion principle, and hence their energy must be subtracted from that of the unperturbed vacuum. This subtraction removes the most severe divergences associated with the one-electron theory, leaving a logarithmic divergence in the second-order self-energy calculation (Weisskopf, 1939).



FIG. 11. From left to right: standing—W. Lamb, K. K. Darrow, V. Weisskopf, G. E. Uhlenbeck, R. E. Marshak, J. Schwinger, and D. Bohm. Seated—J. R. Oppenheimer, A. Pais, R. P. Feynman, and H. Feshbach. Courtesy of Archives of the National Academy of Sciences.

his article “Space-Time Approach in Quantum Electrodynamics,” which he submitted to the *Physical Review* at the beginning of May of 1949:

The conventional electrodynamics was expressed in the Lagrangian form of quantum mechanics described in the *Reviews of Modern Physics* [Feynman, 1948c]. The motion of the field oscillators could be integrated out (as described in Section 13 of that paper), the result being an expression of the delayed interaction of the particles. Next the modification of the delta-function interaction could be made directly from the analogy to the classical case [Feynman, 1948a,b]. This was still not complete because the Lagrangian method had been worked out in detail only for particles obeying the non-relativistic Schrödinger equation. It was then modified in accordance with the requirements of the Dirac equation and the phenomenon of pair creation. This was made easier by the reinterpretation of the theory of holes [Feynman, 1949b]. Finally for practical calculations the expressions were developed in a power series in  $e^2/\hbar c$ . It was apparent that each term in the series had a simple physical interpretation (Feynman, 1949c, p. 770).

Feynman's outline, though accurate and corroborated by his notes and letters, does not convey the “trial-and-error” aspect of the synthesis, nor does it indicate how the diagrammatic component evolved. Moreover, Feynman's “Relativistic Cut-Off for Quantum Electrodynamics,” a paper submitted to the *Physical Review* on July 12, 1948 and published in the November 15, 1948 issue, gives a misleading impression of what he had accomplished up to that time. That article, which presented *some* of his results on the radiative corrections to the properties of an electron in an external electromagnetic field, was written using old-fashioned computational methods, in part to make it comprehensible to the theoretical physics community. In fact, by the Pocono conference of April 1948 Feynman had obtained most of the results that were to be published much later: his version of positron theory; his operator calculus; closed expressions for the transition amplitudes; rules for calculating the contributions to the transition amplitudes to each order of perturbation theory, contributions that could be represented succinctly by diagrams—the famous Feynman dia-

grams; as well as invariant cutoff methods for dealing with the divergences arising from photon exchanges.

What remained to be clarified after Pocono were the problems associated with vacuum polarization and, more generally, the divergences connected with closed loops. After Pocono, Feynman spent a great deal of time and energy developing ever more effective ways of computing more and more complicated diagrams; a synopsis of these methods is to be found in the appendixes of his "Space-Time Approach Quantum Electrodynamics" (Feynman, 1949c).

The clarity and simplicity of the presentation in Feynman's two classic papers, "The Theory of Positrons" (Feynman, 1949b) and "Space-Time Approach to Quantum Electrodynamics" (Feynman, 1949c), belie the magnitude of the task that had been involved in their preparation.<sup>25</sup> Like Schwinger, Feynman had reworked all of quantum electrodynamics and had obtained a formulation that allowed one to bypass the divergence difficulties by using renormalization procedures, and to obtain answers to problems that could not be addressed previously. But as importantly, the relativistically invariant computational techniques he had developed were so effective that in a few hours he could do calculations that would take (or had taken) months, and in some cases years, using conventional techniques. Moreover, these techniques could easily be generalized to apply to meson-theoretic problems.

**B. Classical cutoffs**

Feynman's notes and letters from the summer and fall of 1947 allow us to reconstruct the genesis of his version of quantum electrodynamics. His starting point was the Wheeler-Feynman statement of classical electrodynamics (Wheeler and Feynman, 1945). Feynman adopted the formulation that Wheeler had given in his expanded version of Feynman's 1941 manuscript on the subject. The following exposition is taken from notes written by Feynman during the summer of 1947 entitled "Brief Description of Wheeler-Feynman Electrodynamics" (Feynman, 1947b). These notes later formed the basis for his article "A Relativistic Cut-Off for Classical Electrodynamics" (Feynman, 1948a). The action was taken to be

$$S = \sum_a m_a \int (da_\mu da^\mu)^{1/2} + \sum_{\substack{a,b \\ a \neq b}} e_a e_b \int \dots \int (s_{ab}^2) da_\mu db^\mu. \tag{5.1}$$

<sup>25</sup>In a letter to Cecile Morette in 1950, Feynman indicated that "in general I am very careless in my lectures, so I would appreciate it if they weren't quoted in detail and specific points argued. On the other hand, the papers that I write each take me about a year to get everything straightened out. So I give you full permission to quote from a published paper and argue with the equations" (Feynman, 1950b).

The notation is as follows: particles  $a, b, \dots$  have mass  $m_a$ , charge  $e_a$ , and coordinates  $a_\mu, b_\mu$  ( $\mu=1,2,3,4$ ), which may be considered as functions of parameters  $\alpha, \beta, \dots$  on their paths:

$$\dot{a}_\mu \equiv da_\mu/d\alpha, \quad \dot{b}_\mu \equiv db_\mu/d\beta, \quad \text{etc.} \tag{5.2}$$

The proper time of particle  $a$  is defined by  $d\tau_a = (da_\mu da^\mu)^{1/2}$ ;

$$x_\mu y^\mu = x_4 y_4 - x_1 y_1 - x_2 y_2 - x_3 y_3, \tag{5.3a}$$

$$s_{xy}^2 = (x - y)_\mu (x - y)^\mu, \tag{5.3b}$$

$$\square_x^2 = \frac{\partial}{\partial x^\mu} \frac{\partial}{\partial x_\mu} = \frac{\partial^2}{\partial x_4^2} - \frac{\partial^2}{\partial x_1^2} - \frac{\partial^2}{\partial x_2^2} - \frac{\partial^2}{\partial x_3^2}. \tag{5.3c}$$

Note that

$$\square_x^2 \delta(s_{xy}^2) = 4\pi \delta(x_4 - y_4) \delta(x_1 - y_1) \delta(x_2 - y_2) \times \delta(x_3 - y_3). \tag{5.4}$$

The equations of motion follow from the requirement that the action

$$S = \sum_a m_a \int (\dot{a}_\mu \dot{a}^\mu)^{1/2} d\alpha + \sum_{a,b} e_a e_b \int \delta(s_{ab}^2) \dot{a}^\mu(\alpha) \dot{b}_\mu(\beta) d\alpha d\beta \tag{5.5}$$

be a minimum for all variations of all paths  $a^\mu(\alpha)$  of all particles, i.e., varying  $a^\mu(\alpha)$  to  $a^\mu(\alpha) + \delta a^\mu(\alpha)$ . The following equations result:

$$m_a \frac{d}{d\alpha} \frac{da_\nu}{d\tau_a} = e_a \dot{a}_\mu \sum_{b \neq a} e_b \int \delta'(s_{ab}^2) [2(a_\nu - b_\nu) \dot{b}^\mu - 2(a_\mu - b_\mu) \dot{b}^\nu] d\beta = e_a \dot{a}^\mu \sum_{b \neq a} F_{\mu\nu}^{(b)}(a) \tag{5.6a}$$

or equivalently

$$m_a \frac{d}{d\tau_a} \left[ \frac{da_\nu}{d\tau_a} \right] = e_a \frac{da^\mu}{d\tau_a} \sum_{b \neq a} F_{\mu\nu}^{(b)}(a), \tag{5.6b}$$

where  $F_{\mu\nu}^{(b)}(x)$  is the field at  $x_\mu$  due to particle  $b$ , and is given by

$$F_{\mu\nu}^{(b)}(x) = \frac{\partial A_\mu^{(b)}(x)}{\partial x^\nu} - \frac{\partial A_\nu^{(b)}(x)}{\partial x^\mu}, \tag{5.7a}$$

with

$$A_\mu^{(b)}(x) = e_b \int \dot{b}_\mu \delta(s_{xb}^2) d\beta. \tag{5.7b}$$

By virtue of Eq. (5.4)

$$\square_x^2 A_\mu^{(b)}(x) = 4\pi e_b \int \dot{b}_\mu \delta(x_4 - b_4) \delta(x_3 - b_3) \times \delta(x_2 - b_2) \delta(x_1 - b_1) d\beta = j_\mu^{(b)}(x), \tag{5.8}$$

where the right-hand side of Eq. (5.8) is the 4-current vector of a point charge  $e_b$ . Since

$$\delta(t^2 - r^2) = \frac{1}{2|r|} [\delta(t-r) + \delta(t+r)], \quad (5.9)$$

the  $F_{\mu\nu}$  defined by Eq. (5.7) satisfy Maxwell's equations, but the potentials defined by (5.7b) are half the retarded plus half the advanced solutions of Lienard and Wiechert. The relation of this formulation to the usual theory, which uses only retarded effects, had been expounded at great length in Wheeler and Feynman (1945).

If self-interactions are allowed, then the terms with  $a = b$  are not excluded in Eq. (5.5) for the action. These terms give rise to an infinite contribution, but allow the action to be written in the form

$$S = \sum_a m_a \int d\tau_a + \frac{1}{(4\pi)^2} \int d^4x \int d^4y j^\mu(x) \delta(s_{xy}^2) j_\mu(y). \quad (5.10)$$

Feynman then inquired what happens if one assumes that the action (5.1) is of the form

$$S = \sum_a m_a \int d\tau_a + \frac{1}{2} \sum_{a,b} e_a e_b \iint f(s_{ab}^2) da^\mu db_\mu, \quad (5.11)$$

where  $f$  is an invariant function of  $s_{ab}^2$  that behaves like  $\delta(s_{ab}^2)$  for large distances. Feynman assumed that  $f(s^2)$  is such that interactions exist for  $s$  time-like and less than some small length  $a$  of the order of the classical electron radius  $r_0 = e^2/mc^2$ , i.e., for  $s^2 \leq a^2, a^2 > 0$ . For example,

$$f(s) = \begin{cases} \frac{1}{2a^2} e^{-|s|/a} & \text{for } s^2 > 0, \\ 0 & \text{for } s^2 < 0. \end{cases} \quad (5.12)$$

Note that as long as  $f$  is a function of the interval  $s_{12}$  only, the covariance of the theory is maintained. The form

$$f(s^2) = \int d^4k e^{-ik \cdot (x-y)} \tilde{f}(k^2), \quad (5.13)$$

with  $\tilde{f}$  a function of  $k_\mu k^\mu$  only, is the most general one that will make  $f$  a function of  $s^2$  only;  $\tilde{f}(k_\mu k^\mu) = \delta(k^2)$  yields the original theory with interactions along the light cone only. For calculational purposes Feynman found it

$$e_a \frac{da^\mu}{d\tau} F_{\mu\nu}^{(a)}(a) = 2e_a^2 \int \dot{a}^\mu(\alpha) \dot{a}_\nu(\alpha') [a_\nu(\alpha) - \alpha_\nu(\alpha')] f'(s_{a_\alpha a_\alpha'}^2) d\alpha' - 2e_a^2 \int \dot{a}^\mu(\alpha) \dot{a}_\nu(\alpha') [a_\mu(\alpha) - a_\mu(\alpha')] f'(s_{a_\alpha a_\alpha'}^2) d\alpha'. \quad (5.15)$$

Feynman showed that when the acceleration of the particle is small the right-hand side of Eq. (5.15) reduces to the form  $M d^2 a^\mu / d\tau^2$  with

$$M = e^2 \int_{-\infty}^{+\infty} \epsilon^2 f'(\epsilon^2) d\epsilon + e^2 \int_{-\infty}^{+\infty} f(\epsilon^2) d\epsilon = \frac{1}{2} e^2 \int_{-\infty}^{+\infty} f(\epsilon^2) d\epsilon. \quad (5.16)$$

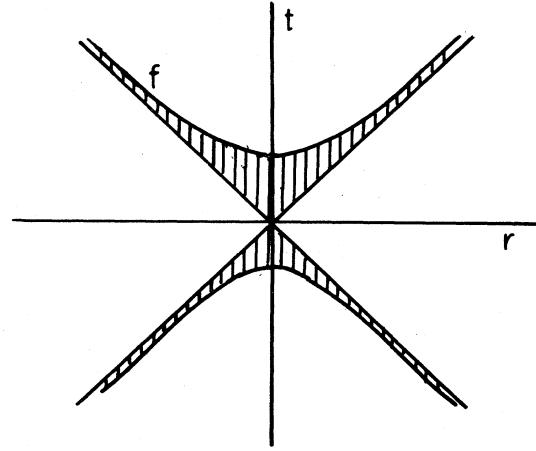

FIG. 12. The cutoff function  $f(s^2)$ .

convenient to consider an  $\tilde{f}$  of the form

$$\tilde{f} = \int_0^\infty [\delta(k^2) - \delta(k^2 - \lambda^2)] G(\lambda) d\lambda \quad (5.14a)$$

with

$$\int_0^\infty G(\lambda) d\lambda = 1. \quad (5.14b)$$

The action (5.1) with the  $\delta(s_{xy}^2)$  function implied that interaction occurred between events  $x$  and  $y$  whose four-dimensional interval vanishes, i.e., between those points  $y$  that lie on the past and future light cone of  $x$ . The consequences of an  $f$  that is different from 0 in the shaded region of Fig. 12, for which  $s^2 = t^2 - r^2 \leq a^2$ , can be inferred as follows:  $(t-r)(t+r) \leq a^2$  implies that when  $r \gg a$ ,  $t-r \approx a^2/2r$ . Hence the velocity of propagation at large distances approaches closer and closer to the velocity of light  $c$ . Similarly, when  $t$  is large, since  $\Delta s^2 = 2t\Delta t$ , there is a spread in the time of arrival of an electromagnetic signal of the order of  $a^2/2t$ . Thus the interaction between charges separated by a large distance remains essentially unchanged; there is a slight alteration of the interactions when particles are close to one another (i.e., when  $r_{ij} \sim a$ ). There is, however, considerable modification of the action of a charged particle on itself: the infinite self-energy is reduced to a finite value. When the terms  $a = b$  are included in the action the self-force is of the form

The mass is positive and, if desired, all the mass of the particle could be considered as electromagnetic in origin.

Feynman obtained another important result. He realized that the action (5.11) allowed the possibility of describing pair production in an external field in this classical theory by considering positrons as electrons running backwards in time, the idea previously suggested to him

by Wheeler (see Feynman, 1948a, pp. 943–944).

The purpose of Feynman's investigation of classical electrodynamics with a cutoff was to formulate a finite and consistent theory that included self-interactions and that could be quantized using his integral-over-path formulation of quantum mechanics. The replacement of the  $\delta$  function by a smooth function  $f(s_{xy}^2)$  in the interaction term of the Fokker action, i.e., in the term

$$\int \int d^4x d^4y j_\mu(x) \delta(s_{xy}^2) j^\mu(y),$$

indeed yielded a finite theory. Furthermore, it was possible to establish the equivalence of this  $\frac{1}{2}$  (advanced + retarded) formulation of classical electrodynamics to the usual retarded formulation in a universe where all radiation is absorbed at infinity (Feynman, 1948a, Appendix).

A quantum-theoretic proof of the equivalence was more ambiguous. In any case the immediate problem that Bethe had posed was to indicate how one introduces a cutoff in the quantized version of the usual *retarded* electrodynamics. Feynman knew from the researches that he had carried out for his thesis that the elimination of the transverse oscillators in the retarded formulation of quantum electrodynamics yielded, for the interaction action that entered into the transition amplitude, an expression very similar to Eq. (5.10), the difference being that the  $\delta$  function was replaced by another singular function, the function Feynman later called the  $\delta_+(s^2)$  function.

### C. Elimination of radiation oscillators

In a set of notes written during the summer of 1947, Feynman (1947c) once again carried out the calculation of the elimination of the transverse oscillators in the expression for the transition amplitude for a theory of nonrela-

tivistic particles interacting with the quantized electromagnetic field. Feynman had performed an essentially identical calculation for his dissertation (Feynman, 1942) and for Section 13 of his "Space-Time Approach to Non-Relativistic Quantum Mechanics" (Feynman, 1948c). In each case the point of departure was Fermi's formulation of quantum electrodynamics as presented in his famous 1932 *Reviews of Modern Physics* article. It was from this exposition (Fermi, 1932) that Feynman had learned QED when writing his thesis, and "almost [his] entire knowledge of QED came from this simple paper by Fermi" (Feynman, 1985a). The results obtained are those set forth in the first four sections of the article "Mathematical Formulation of the Quantum Theory of Electromagnetic Interaction" (Feynman, 1950a, pp. 441–445). The Lagrangian was taken to be

$$L = L_p + L_{tr} + L_I + L_c, \tag{5.17}$$

where

$$L_p = \frac{1}{2} \sum_n m_n \dot{\mathbf{x}}_n^2 \tag{5.18a}$$

is the Lagrangian of the particles,

$$L_{tr} = \frac{1}{2} \sum_{\mathbf{k}} \sum_{r=1}^4 [(\dot{\mathbf{q}}_{\mathbf{k}}^{(r)})^2 - k^2 (q_{\mathbf{k}}^{(r)})^2] \tag{5.18b}$$

is the Lagrangian of the transverse electromagnetic field,

$$L_c = -\frac{1}{2} \sum_n \sum_m e_n e_m / r_{mn} \tag{5.18c}$$

is the Coulomb interaction term, and

$$L_I = \sum_n e_n \dot{\mathbf{x}}_n \cdot \mathbf{A}^{tr}(\mathbf{x}_n) \tag{5.18d}$$

is the interaction Lagrangian, with

$$\mathbf{A}^{tr}(\mathbf{x}) = (8\pi)^{1/2} \sum_{\mathbf{k}} [\mathbf{e}_{2\mathbf{k}}(q_{\mathbf{k}}^{(1)} \cos \mathbf{k} \cdot \mathbf{x} + q_{\mathbf{k}}^{(3)} \sin \mathbf{k} \cdot \mathbf{x}) + \mathbf{e}_{2\mathbf{k}}(q_{\mathbf{k}}^{(2)} \cos \mathbf{k} \cdot \mathbf{x} + q_{\mathbf{k}}^{(4)} \sin \mathbf{k} \cdot \mathbf{x})], \tag{5.19}$$

where  $\mathbf{e}_{1\mathbf{k}}$  and  $\mathbf{e}_{2\mathbf{k}}$  are two orthogonal unit polarization vectors perpendicular to the direction of propagation  $\mathbf{k}$ . The sum over  $\mathbf{k}$  means, for unit volume,  $\int d^3k / (2\pi)^3$ , and each  $q_{\mathbf{k}}^{(r)}$  can be considered as the coordinate of a harmonic oscillator, since the transverse part has a Lagrangian given by Eq. (5.18b). The elimination of the transverse oscillators can be done one at a time.

In the transition amplitude for the matter system to go from a state  $\chi_{i'}$  at  $t'$  to the state  $\chi_{i''}$  at  $t''$  and the radiation field remaining in its vacuum state  $\phi_0$  (i.e., with no photon emission, none being present initially), the result of this elimination is the following expression:

$$\langle \chi_{i''} \phi_{0t''} | \chi_{i'} \phi_{0t'} \rangle = \int \int d(\text{particle variables}) \bar{\chi}_{i''} \exp \left\{ \frac{i}{\hbar} (S_p + S_{int}) \right\} \chi_{i'} \mathcal{D}(\text{path particle variables}), \tag{5.20}$$

with  $S_{int}$  given by

$$S_{int} = \frac{i}{2} \sum_n \sum_m e_n e_m \int_{t'}^{t''} \int_{t'}^{t''} [1 - \dot{\mathbf{x}}_n(t) \cdot \dot{\mathbf{x}}_m(s)] \delta_+ \{ (t-s)^2 - [\mathbf{x}_n(t) - \mathbf{x}_m(s)]^2 \} dt ds, \tag{5.21}$$

where the  $\delta_+$  function is defined by

$$\delta_+(x) = \frac{1}{\pi} \int_0^\infty e^{-ikx} dk = \lim_{\epsilon \rightarrow 0} \frac{-i}{\pi(x - i\epsilon)} \tag{5.22a}$$

$$= \delta(x) - \frac{i}{\pi x}. \tag{5.22b}$$

Feynman's (1947c) notes contain extensive discussions of the transient terms [that have been omitted in Eq. (5.20)] that occur because the amplitude is being evaluated from a (sharp) time  $t'$  to the (sharp) time  $t''$ . The interaction term is invariant. The invariance is made explicit by noting that

$$1 - \dot{\mathbf{x}}_n(s) \cdot \dot{\mathbf{x}}_m(t) = \dot{\mathbf{x}}_{n\mu}(s) \dot{\mathbf{x}}_{m\mu}(t).$$

For the case of a single charged particle, the amplitude for remaining in the initial state  $\psi_0$  (the state at  $t'=0$ ) after a long time  $t''=T$  is given by

$$\langle \psi_{0T} | \psi_{00} \rangle = \int_0^T \int_0^T \mathcal{D}(\text{path}) dx_T dx_0 \psi_0^*(x_T) \times \exp \left[ \frac{i}{\hbar} \left[ S_p[x(t)] + \frac{ie^2}{\hbar c} \int \int [1 - \dot{\mathbf{x}}(t) \cdot \dot{\mathbf{x}}(s)] \delta_+((t-s)^2 - [\mathbf{x}(t) - \mathbf{x}(s)]^2) \right] ds dt \psi_0(x_0) \right]. \tag{5.23}$$

If the particle did not interact with the radiation field (and hence would not interact with itself), the time dependence of  $\langle \psi_{0T} | \psi_{00} \rangle$  would be  $\exp(-iE_0T)$ , with  $E_0$  the energy of the unperturbed state  $\psi_0$ . In the presence of self-interaction,

$$\langle \psi_{0T} | \psi_{00} \rangle = e^{-iR_0T - iE_0T}, \tag{5.24}$$

where  $R_0$ —the effect of interaction—is assumed to be small so that it can be expanded in powers of  $e^2/\hbar c$ . Writing  $e^{-iRT} \approx 1 - iRT$ , and expanding in powers of  $e^2/\hbar c$ , Feynman obtained the following expression for  $R_0$ :

$$R_0 = \lim_{T \rightarrow \infty} \frac{e^{iE_0T}}{T} \frac{e^2}{\hbar c} \int \int dx_0 dx_T \mathcal{D}(\text{paths}) \psi_0^*(x_T) e^{iS_p} \int_0^T \int_0^T \dot{\mathbf{x}}_\mu(t) \dot{\mathbf{x}}_\mu(s) \delta_+ \{ (t-s)^2 - [\mathbf{x}(t) - \mathbf{x}(s)]^2 \} ds dt \psi_0(x_0). \tag{5.25}$$

This expression is symmetric in  $s$  and  $t$ . Assuming that  $s$  is later than  $t$  (and therefore multiplying the result by 2), and holding fixed the space-time points  $x_t, t$  and  $x_s, s$ , the integration over paths can be performed and yields the result

$$R_0 = \frac{2ie^2}{\hbar c} \lim_{T \rightarrow \infty} \frac{e^{iE_0T}}{T} \int dx_t \int dx_s \int_0^T dt \int_0^T ds \psi_0^*(x_s, T-s) \dot{\mathbf{x}}_\mu(s) K_0(x_s, s; x_t, t) \dot{\mathbf{x}}_\mu(t) \delta_+ [(t-s)^2 - (\mathbf{x}_t - \mathbf{x}_s)^2] \psi_0(x_t, t). \tag{5.26}$$

Inserting into this expression the representations for  $\delta_+$  and  $K_0$ ,

$$\delta_+(x_\mu^2) = -\frac{i}{2\pi} \int \frac{d^3k}{k} e^{ik \cdot x} e^{-ikt} \tag{5.27}$$

and

$$K_0(2, 1) = \sum_n \psi_n(\mathbf{x}_2) \psi_n^*(\mathbf{x}_1) e^{-iE_n(t_2-t_1)}, \tag{5.28}$$

Feynman deduced that

$$R_0 = \frac{2e^2}{\hbar c} \sum_n \int \frac{d^3k}{2\pi k} \frac{(0 | e^{ik \cdot x} \dot{\mathbf{x}}_\mu | n)(n | e^{-ik \cdot x} \dot{\mathbf{x}}_\mu | 0)}{E_0 - E_n - \hbar ck}. \tag{5.29}$$

The real part of  $R_0$  gives rise to the infinite shift in energy levels; the imaginary part—which gives rise to a time dependence of the form  $e^{+R_{im}T}$  in the transition amplitude—is the reciprocal lifetime of the state. The real part—upon neglecting the retardation factors  $e^{ik \cdot x}$ —is identical to Bethe's expression for the level shift. After mass renormalization Feynman showed it to correspond to Bethe's formula for the Lamb shift.

Equation (5.29) applies also to a Dirac particle, except in that case the velocity operators  $\dot{\mathbf{x}}(t)$  must be replaced by the Dirac  $\alpha$  matrices, the "velocity" operator for a

Dirac particle, or equivalently  $\dot{\mathbf{x}}_\mu$  by  $\gamma_\mu$  with the understanding that  $\psi^*$  goes over the adjoint spinor. This correspondence was shown to be correct by noting that Eq. (5.29) then yielded the expression for the second-order self-energy for a Dirac particle. Although the perturbation-theoretic formula Feynman obtained by the replacement  $\dot{\mathbf{x}}_\mu \rightarrow \gamma_\mu$  was anticipated, the precise structure depended on what was assumed for  $K$  in this situation. Stated differently, in the sum over intermediate states, different choices for  $K$  resulted in either the hole-theoretic result (all the negative-energy states filled) or the result stemming from a one-particle theory.

With the hole-theoretical specification of the intermediate states, Eq. (5.29) generalized to Dirac particles yielded the expression for the self-energy that Weisskopf (1939) had derived. In that expression the integral  $d^3k/k$  over  $\mathbf{k}$  space could be replaced by its equivalent form,

$$2 \int d\omega d^3k \delta(\omega^2 - \mathbf{k}^2),$$

the integral being over all positive  $\omega$  and all wave numbers  $\mathbf{k}$ . This step allowed Feynman to introduce his cut-off by replacing  $\delta(\omega^2 - \mathbf{k}^2)$  by  $g(\omega^2 - \mathbf{k}^2)$ , with

$$g(\omega^2 - \mathbf{k}^2) = \int_0^\infty [\delta(\omega^2 - \mathbf{k}^2) - \delta(\omega^2 - \mathbf{k}^2 - \lambda^2)] G(\lambda) d\lambda, \tag{5.30a}$$



$$\int_0^\infty G(\lambda)d\lambda=1. \quad (5.30b)$$

The self-energy evaluated with  $g(\omega^2-\mathbf{k}^2)=\delta(\omega^2-\mathbf{k}^2)-\delta(\omega^2-\mathbf{k}^2-\lambda^2)$  (and with the intermediate states specified by hole theory) yielded a convergent result, but a result that depended logarithmically on the cutoff  $\lambda$  (Feynman, 1948b).

These results were first obtained in a somewhat more haphazard fashion. However, one of the things that had been clear to Feynman—and this since the time of his thesis—was that one need not treat the contributions of the longitudinal and transverse photons separately. In his Nobel Prize speech, Feynman noted

I was very surprised to discover that it was not known at that time that every one of the formulas that had been worked out so patiently by separating longitudinal and transverse waves could be obtained from the formula for the transverse waves alone, if instead of summing over only the two perpendicular polarization directions you would sum over all four possible directions of polarization. It was so obvious from the action [ $\int j_\mu(x)\delta_+(x-y)^2j_\mu(y)d^4xd^4y$ ] that I thought it was general knowledge and would do it all the time. I would get into arguments with people, because I didn't realize they didn't know that (Feynman, 1966a, p. 706).

Where matters stood at the end of the fall of 1947 can be gauged from a letter Feynman wrote to Bert and Mulaika Corben, with whom he had spent part of the summer in Pittsburgh.<sup>26</sup>

I have been working very hard recently so there has been no letter. But interesting things are piling up, so I thought I had better write some of them to you.

I sent my paper to the *Physical Review* and have not heard, as yet, about it but I have continued working with electro-dynamics in the range of quantum mechanics which is described in the paper. You may remember I was able to eliminate explicit reference to the field oscillation in the equations of quantum mechanics. While I was working on this, there was so much talk around here about self-energy, that I thought it would be the easiest thing to calculate directly in my form. The result is exactly the same as one gets for ordinary perturbation theory (except for some nice simplification waves [*sic*; ways]). It therefore also gives infinity. I then altered the delta function in the interaction to be a somewhat less sharp function. This corresponds to a kind of finite elec-

tron. Then the self-energy of a non-relativistic particle is finite. Actually it comes out complex, the imaginary part represents the rate of radiation to the negative-energy states. If I cause the negative energy states to be full, then the formation is no longer relativistically invariant and gives a finite self-energy to an electron, in fact all mass can be represented as electro-magnetic.

It therefore seems that I have guessed right, that the difficulties of electro-dynamics and the difficulties of the hole theory of Dirac are independent and one can be solved before the other. I am now working on the hole theory, in particular, I now understand the Klein paradox, so that it is no longer a paradox and can tell you what an atom with a nuclear charge more than 137 would behave like, but I still haven't solved the whole problem. The main reason I am writing to you, is to tell you about this result which I feel is of very great significance.

It is very easy to see that the self-energy of two electrons is not the same as the self-energy of each one separately. That is because among the intermediate states which one needs in computing the self-energy of particle number 1, say, the state of particle 2 can no longer appear in the sum because a transition of 1 into the state of 2 is excluded by the Pauli exclusion principle. The amount by which the self-energy of two particles differs from the self-energy of each one separately is actually the energy of their electrical attraction.<sup>27</sup> Therefore, the electro magnetic interaction between two particles can be looked upon as a correction to the self-energy produced by the exclusion principle. Thus Eddington is right in that it is a consequence of the exclusion principle.<sup>28</sup>

Finally, I have learned that the classical theory with a finite electron which is deduced from a principle of least action, can show the phenomenon of pair production. The action is made a minimum sometimes by a pair which reverses itself in time, in the way we have discussed often when I was there (Feynman, 1947e).

On 12 November 1947, Feynman gave a seminar at the Institute for Advanced Study on "Dirac's Electron from Several Points of Views." He had stopped in Princeton on his way to attend the Tenth Washington Conference in Theoretical Physics, which took place from Thursday to Saturday 13, 14, and 15 November 1947. Arthur Wightman attended Feynman's lecture. His notes indicate that Feynman briefly presented the content of his RMP article and proceeded to derive Eqs. (5.20) and (5.21) for the transition amplitude. An explicit formula was given for the  $S_{\text{int}}$  for the case of two interacting particles:

<sup>26</sup>Feynman had met Bert Corben at Princeton in 1941 when Corben was studying with Pauli at the Institute for Advanced Study. Corben had returned to the United States from Australia in July 1946 to accept a position at the Carnegie Institute of Technology in Pittsburgh. The Corbens had met Feynman at the New York meeting of the APS in January of 1947 and had invited him to Pittsburgh for part of the summer (Corben, 1984).

<sup>27</sup>A set of notes labeled "Self-interactions of 2 particles," that Feynman wrote during the summer of 1947, gives the mathematical details (Feynman, 1947d).

<sup>28</sup>Feynman had read Eddington's *Fundamental Theory* with Welton in 1937 (Welton, 1983).

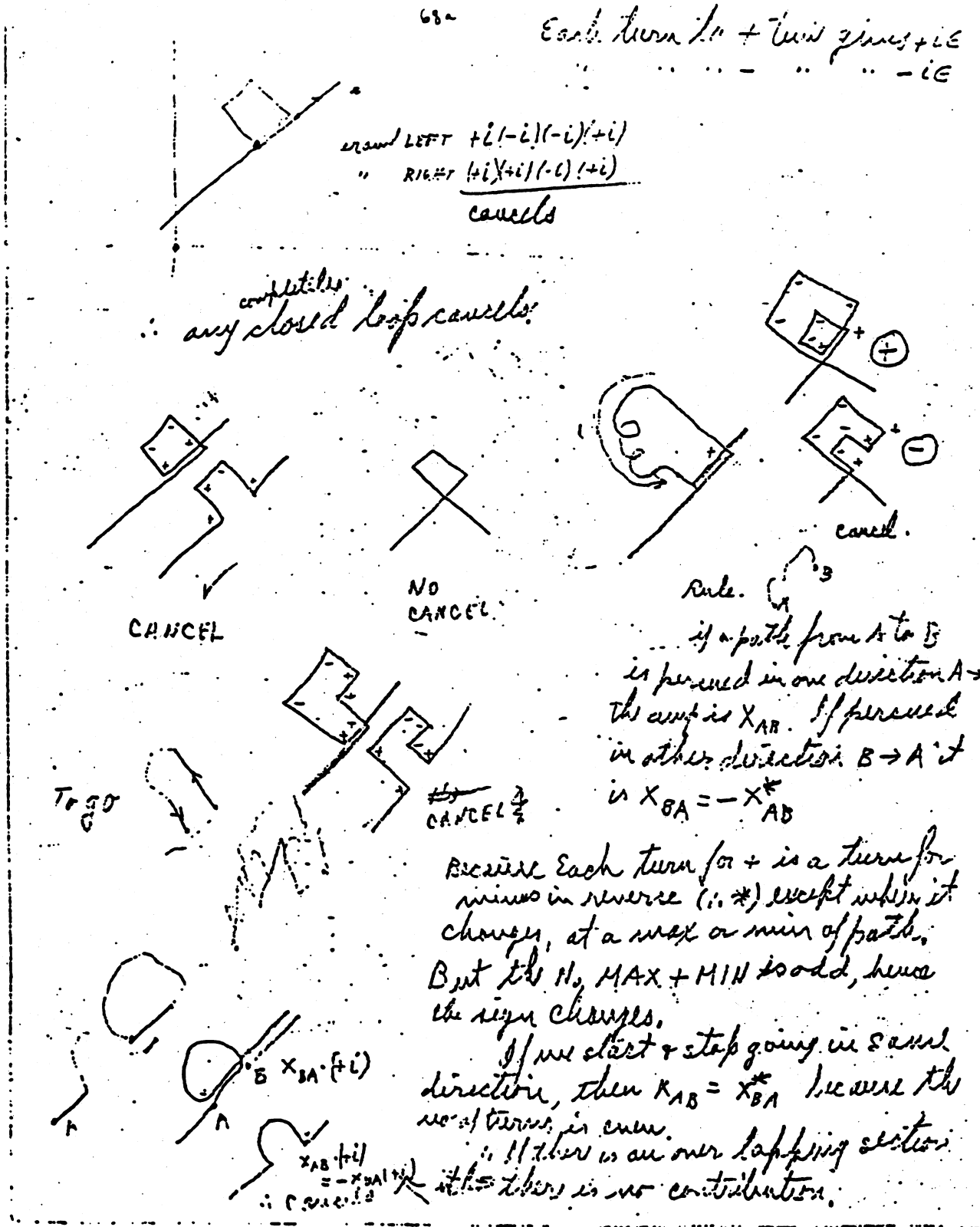

FIG. 13. Space-time paths for one-dimensional Dirac particle, fall 1947 (Feynman, 1947h).

$$S_{\text{int}}(x,y) = \frac{e_x e_y}{4\pi} \int_0^T \int_0^t (1 - \dot{\mathbf{x}}(t) \cdot \dot{\mathbf{y}}(s)) \left[ \delta(t-s)^2 - [\mathbf{x}(s) - \mathbf{y}(t)]^2 + \frac{i/\pi}{(t-s)^2 - (\mathbf{x}_t - \mathbf{x}_s)^2} \right] ds dt$$

and Eq. (5.25) was written down "for the contribution to the energy shift" (Wightman, 1947). During the rest of his lecture Feynman reviewed his various attempts to give an integral-over-path formulation for the Dirac electron. It is of interest to note that Feynman's original attempts to "derive" the Dirac equation involved space-time trajectories which had the property that the time parameter only increased along the paths. In his lecture at Princeton, the paths could now go backwards in time (see Figs. 13 and 14).

Dirac, who was visiting the Institute during that academic year, attended Feynman's seminar. Harish-Chandra, who at the time was a student of Dirac's, reported to Mrs. Corben that "Dirac is very impressed by Feynman and thinks he does some interesting things..." (M. Corben, 1947).

From Princeton Feynman went to Washington to at-

tend the Washington Theoretical Physics Conference, whose subject was "Gravitation and Electromagnetism." At the meeting Schwinger briefly lectured on the results he had obtained since the Shelter Island conference. Schwinger's comments were the only worthwhile report to the conference as far as Feynman was concerned. Writing to the Corbens on 19 November, Feynman (1947f) described it to them:

The meeting in Washington was very poor, don't quote me. The only interesting thing was something that Schwinger said at the end of the meeting. It was interesting because it got Oppy so excited but I did not have time to understand exactly what Schwinger had done. It has to do with the electro-magnetic self-energy problems. *One thing he did point out that was very interesting though, was that the discrepancy in the hyperfine structure of the hydrogen noted by Rabi, can be ex-*

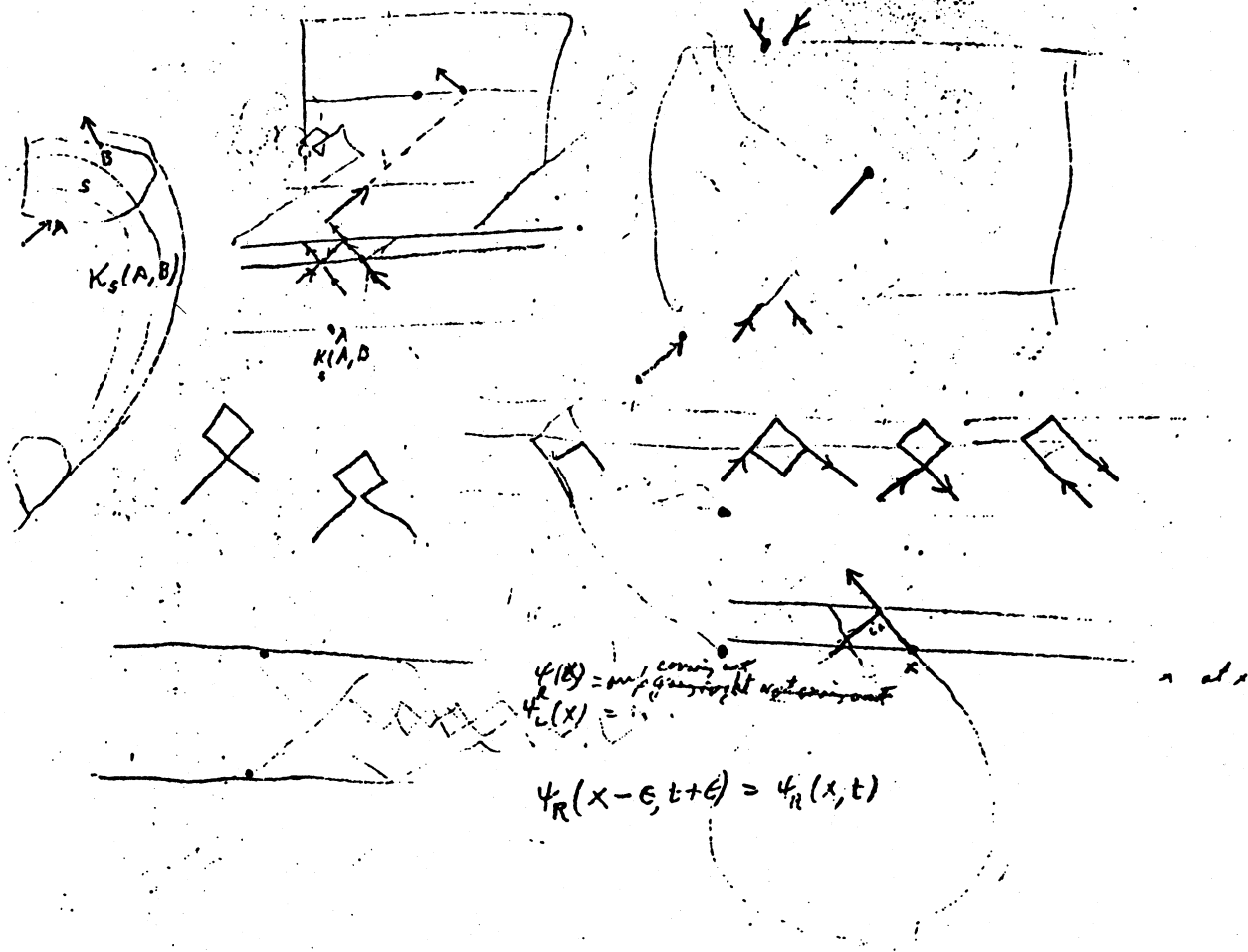

FIG. 14. Space-time paths for Dirac particle in one dimension, fall 1947 (Feynman, 1947h).

plained on the same basis as that of electro-magnetic self-energy, as can the line shift of Lamb. (Italics mine.) The rest of the meeting was concerned with gravitation and the curvature of the universe and other problems for which there are very powerful mathematical equations—lots of speculation but very little evidence.

I met Mrs. Schwinger and had hoped to come back to Princeton from Washington with them on the train. I was going to find out from Julie [*sic*; Julian] then, what he was trying to explain at the meeting. Unfortunately they did me dirt and did not come to Princeton. I stopped off at Princeton on my way back to Ithaca to talk to Pias [*sic*, Pais] and Bohm and used up all my time with Pias—unfortunately, because I also wanted very much to talk to Bohm (Feynman, 1947f).

Schwinger's observation could readily be incorporated into Feynman's approach by considering  $S_p$  in Eq. (5.25) to be the action for a charged particle in an external electromagnetic field. The transition matrix for radiationless scattering by the external field could then be calculated to first order in the external field and to order  $e^2/\hbar c$  in the radiative corrections. This problem had just been reexamined by Lewis (1948). Lewis had redone Dancoff's calculation (Dancoff, 1939) and had discovered that Dancoff had made an error. (Dancoff had omitted certain matrix elements.) Lewis found that after mass renormalization the amplitude for radiationless scattering—although infrared divergent<sup>29</sup>—did not contain any ultraviolet divergences. Feynman calculated the amplitude for radiationless scattering using his photon cutoff and obtained the results to be found in his paper "Relativistic Cut-Off for Quantum Electrodynamics" (Feynman, 1948b).

By the middle of January 1948, just prior to the New York meeting of The American Physical Society, Feynman (1948d) could report to the Corbens:

In the last letter I wrote you, I made a mistake.<sup>30</sup> As you know, I have been working with a theory of electricity in which the delta function interaction is replaced by a less sharp function. Then (in quantum mechanics) the self-energy of an electron including the Dirac hole theory comes out finite. The mistake in the last letter was to say that it is finite and not relativistically invariant. Ac-

tually, the self-energy comes out finite and invariant and is therefore representable as a pure mass. The magnitude of the mass change is a fraction of the order of  $1/137$  times the logarithm of the Compton wavelength over the cutoff width of the delta function. Thus, all mass cannot be represented as electrodynamic unless the cutoff is ridiculously short. The experimental mass is of course the sum of inertia and this electromagnetic correction.

I then turned to the problem of radiationless scattering which has always given such trouble in electrodynamics. I get the result that the cross section for scattering of a particle going past a nucleus without emitting a quantum is finite. If the cutoff is made to go to zero, the answer comes out infinite. If, however, the cross section is first expressed in terms of the experimental mass and then the cutoff is made to go to zero keeping the experimental mass as a constant, when the limit is taken, the result is finite. This therefore agrees with the result of Lewis and Oppenheimer. I believe it also confirms the idea of Schwinger because I think that the terms which diverge logarithmically as the cutoff goes to zero are just the terms that Schwinger said one should subtract in a consistent electrodynamics.

I have not computed the self-energy to second order,<sup>31</sup> I only hope it is also finite. If so, I think all the problems of electrodynamics can be unambiguously solved by this process: First compute the answer which is finite (but contains the cutoff logarithm). Then express the result in terms of the experimental mass. The answer still contains the cutoff but this time not logarithmically. Take the limit which now exists, as the cutoff goes to infinity.

I have not mentioned polarization of the vacuum for as yet I do not completely understand the problems in which it appears. However, a calculation of the phenomenon also gives a [in]finite answer for the polarizing of the vacuum. This can be removed by a renormalization of the electric charge. However, unfortunately for reasonable cutoff, the polarizability is very large as far as I can see, so that things do not look as nice as they do for self-energy.

I am very excited by all this of course, because I think that the problem is at least solved either by my way or Schwinger's. I hope to prove the equivalent or at least to compare the two ideas shortly (Feynman, 1948d).

At the New York meeting of The American Physical Society at the end of January 1948, Schwinger gave an invited lecture on "Recent Developments in Quantum Electrodynamics." This lecture had to be repeated a second time because of the vast number of people unable to hear him the first time. In his address, Schwinger reported on his calculation of the anomalous magnetic moment of a free electron and his initial results for the Lamb shift. He also indicated that he had encountered some difficulties: the calculated value of the anomalous magnetic moment of an electron in a Coulomb field did not agree with the value  $\alpha/2\pi$  he had calculated for a quasifree electron.

<sup>29</sup>Bloch and Nordsieck (1937) had shown the origin and solution of that particular difficulty. It arises from the fact that it is impossible to scatter an electron without the emission of some (very soft) photons.

<sup>30</sup>Feynman (1985a) indicates that the story of his mistake is interesting. "As near as I can remember it, I first got a relativistic result (we were only working to order  $v^2/c^2$ ). A student found an error in an early line and concluded it would not be invariant—when I wrote the first letter. But later on, several pages later, he found another error where I cancelled two equal complicated terms that I should have added. The original answer I had gotten was right—it was relativistic. This miracle of two cancelling errors was probably the result of a mixture of having a strong feeling for what the answer must be and algebraic carelessness."

<sup>31</sup>By second order Feynman meant to order  $(e^2/\hbar c)^2$ .

The reason for the discrepancy was that Schwinger's calculational methods were not relativistically invariant (Schwinger, 1983, pp. 335–336).

After Schwinger's talk Feynman got up and reported that he had computed all the things Schwinger had and that he agreed with Schwinger's result, except that he had found the magnetic moment of an electron in an atom also to be  $(1 + \alpha/2\pi)e\hbar/2mc$ . If the calculations maintained proper covariance there were really no difficulties. Feynman (1966b) claims he "wasn't trying to show off"; he was trying to tell Schwinger that "he had caught up."<sup>32</sup> On 20 March Feynman (1948e) wrote the Corbens

I have been working on my little theory of electrodynamics in which the interaction is not exact on a delta function because there was some confusion in the Schwinger-Weisskopf-Bethe Camp as to what the correct answer was for the line shift. I worked that out in detail, my way. I find a shift in the magnetic moment of an electron equal to  $e^2/2\pi\hbar c$ . The line shift in hydrogen has two terms, one a logarithmic one proportional to the expected form of  $\nabla^2 V$  and the other is a correction to the spin orbit interaction. This correction is exactly the same as the amount that you would calculate from the change in the magnetic moment that is, everything is nicely relativistically invariant. The calculation took me four days and can be put neatly on four pages of paper. Now that I understand it, it is really a very simple problem. What I did, was to compute the change in the Dirac Hamiltonian due to the fact that an electron can emit and absorb virtual quanta when it is in a slowly varying external potential. If  $\phi$  and  $A$  are the scalar and vector potential in a problem, the correction to the Hamiltonian is

[no formula was inserted in the carbon copy of the letter] the answer diverges for very low energy quanta, so I have expressed it in terms of  $k_{\min}$  which are the slowest momentum quanta which have been included. This avoids the infrared catastrophe and the low energy non-relativistic end can be worked out in a straightforward way, such as has already been done by Bethe. The actual shift comes out around 1040 megacycles, I think.

My theory of representing positrons as electrons going backward, is working very well but nobody believes me because I haven't got everything complete yet. I can only deal with pair production and annihilations in a complete fashion. Polarization of the vacuum still remains somewhat of a puzzle; it has not been included in the above formula for  $\Delta H$ .

Feynman's letter indicates that by the spring of 1948 he had fully incorporated "Wheeler's old idea about electrons going backward in time being positrons" into his formulation of quantum electrodynamics.

#### D. Theory of positrons

There exists a set of notes with the title "Theory of Positrons," probably written in late 1947, which outlines

<sup>32</sup>To some people close to Feynman at the time it did seem that Schwinger was "at least his personal competitor" (Eyges, 1984).

Feynman's formulation of the theory as of that time (Feynman, 1947g). The notes begin with the statement

We shall consider that when an electron travels along as proper time increases so does true time. For a positron proper time increases as true time decreases. This is classically. Quantum mechanically the situation is that the wave function has a phase (in  $e^{-i\phi}$  define  $\phi$  as phase) which increases as you move in positive true time for an electron, and increases in negative true time for a positron (Feynman, 1947g).

Denote by  $\psi(x)$  the amplitude for an electron to arrive at  $x$ ;  $\psi(x)$  contains only the positive energy components. "If a positron were to arrive at  $x$ , it would come from a wave from the future of  $x$  & would give a  $\psi(x)$  with only negative-energy components."

Feynman then considers the action of a potential at  $\boxtimes$  and notes that

Whereas Dirac says  $\boxtimes$  sends an electron initially at  $A$  into states of positive and negative energy . . . both of which spread upward in time. We [Feynman] say instead that  $\boxtimes$  scatters a wave  $B$  toward future representing scattered electron, and a wave  $C$  toward past representing . . . a positron with which the electron may have annihilated by action of potential at  $\boxtimes$ . . . (Fig. 15).

The amplitude (scattered) arriving at (2) electron is (to first order in  $A$ )

$$\int \mathcal{S}(2,x) \frac{i}{\hbar} A(x) \psi(x) d^4x ,$$

$$A = \gamma_\mu A_\mu .$$

The amplitude for the positron arriving at 3 is

$$\int \mathcal{S}(3,x) \frac{i}{\hbar} A(x) \psi(x) d^4x ,$$

where

$$\mathcal{S}(A,B) = (i\nabla + \mu)I(A,B), \quad \nabla = \gamma_\mu \frac{\partial}{\partial x_\mu}$$

with  $I(A,B)$  a complex time-symmetrical solution of  $(\square^2 - \mu^2)I(A,B) = 0$  having the property that it only has positive-frequency components for  $t_A - t_B > 0$  and negative-frequency components where  $t_A - t_B < 0$ . Feynman then obtains the explicit representation for  $I$ ,

$$I(1,2) = \int d^4p e^{-ip \cdot x} \frac{1}{p_\mu p_\mu - \mu^2} , \tag{5.31}$$

"where  $\mu^2$  is considered to have an infinitesimal negative imaginary part . . ." Thus the Fourier transform of the  $\mathcal{S}$  operator is  $(\gamma_\nu p_\nu + \mu)/(p_\mu^2 - \mu^2 + i\delta)$ . It is clear that the approach is based upon the perturbative expansion

$$\mathcal{S}A(x,y) = \mathcal{S}(x,y) + \int \mathcal{S}(x,x') \frac{i}{\hbar} A(x') \mathcal{S}(x',y) d^4x' + \dots \tag{5.32}$$

for what will be called the propagator. Analyzing the second-order contribution, Feynman noted that the term  $\mathcal{S}\mathcal{S}A\mathcal{S}$  includes the contribution from *both* of the diagrams indicated in the upper left-hand corner of Fig. 16.

Theory of Positrons

①

We shall consider that when an electron travels along as proper time increases so does true time. For a positron proper time increases as true time decreases. This is classically. Quantum mechanically the situation is that the wave function has a phase (in  $e^{-i\phi}$  defn of phase) which increases as you move in positive true time for an electron and increases in negative true time for a positron. Further

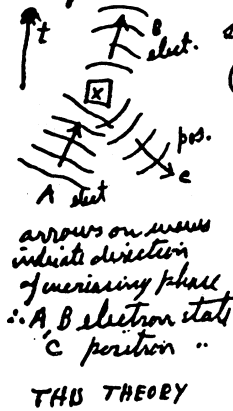

suppose a potential at  $x$  <sup>at a small element of  $V(x)$</sup>  or space time. An electron (at A) splits and is present as time goes on, the phase increasing as indicated by the arrows. Now Dirac says  $x$  sends  $A$  into states of positive and negative energy both of which spread upward in time. ( $\pm$  phase change with  $t$ ). We say instead that  $x$  scatters a wave B toward future ~~plus~~ representing scattered electron, and a wave C toward past representing (in quantitative case made more clear later) a positron with which the electron may have annihilated by action of the potential at  $x$ .

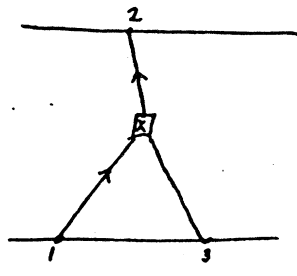
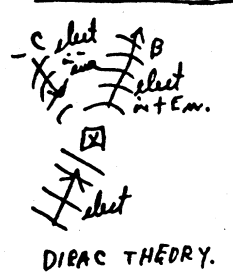

Now suppose the electron wave function arriving at  $x$  by  $\psi(x)$ . (Thus  $\psi(x)$  contains only plus energy components) If a positron were to arrive at  $x$ , it would come from a wave from the future of  $x$  & would give  $\psi(x)$  with only  $-$  energy components - This general case considered later. The source of the scattered

wave is then  $\int A_n(x) \psi(x)$  or as we will write  $\hat{A}(x) \psi(x)$  (the  $\hat{}$  meaning an operator).  
 The amplitude (scattered) arriving at  $z$  (electron) is say  $\int \hat{S}(z, x) \hat{A}(x) \psi(x) dV_x$  (1st order in  $A$ )  
 ... .. 3 (positron) ...  $\int \hat{S}(z, x) \hat{A}(x) \psi(x) dV_x$  (...)  
 Here  $\hat{S}(A, B)$  is a function (operator) of  $A, B$  which we have therefore defined <sup>later</sup> when  $t_A > t_B$  and  $t_A < t_B$ . ~~It~~ It is a function only of  $R_{AB}$  and  $t_{AB}$ . ~~say say~~  $\hat{S}(R_{AB}, t_{AB})$   
 We show later it is complex, and ~~is~~ time symmetrical  $\hat{S}(R_{AB}, t_{AB}) = \hat{S}(R_{AB}, -t_{AB})$ .  
 (It is  $\hat{S}(R_{AB}, t_{AB}) = (\int \frac{\partial}{\partial x_A} + \mu) I(R_{AB}, t_{AB})$  where  $I$  is a number (no operator) time symmetrical outgoing wave solution of  $(\nabla^2 - \mu^2) I = 0$  except at  $B$  where there is unit source  $\delta(R - R_B) \delta(t - t_B)$ . and therefore involves direct & retarded functions of  $R_{AB} - t_{AB}$ ).

FIG. 15. From Feynman's notes, "Theory of Positrons," fall 1947 (Feynman, 1947g).

with two potential points.

Let us discuss amplitudes transition to go from electron at S to find electron at T. It is  $\psi(x,s)$ . We figure the term of order  $A(x)A(y)$ : It is  $\int \psi(T,Y) A(Y) \psi(Y,X) A(X) \psi(X,S) + \psi(T,X) A(X) \psi(X,Y) A(Y) \psi(Y,S)$

The first represents scattering at x followed by that at y. The second represents a pair created at x, the positron of which annihil. s electron at y, and the electron of which is found at T.

To verify these interpretations we can calculate the quantities in 3-momentum space + time, and initial of 3-coord. space + time. Momenta of fields at times  $t_x, t_y$  are  $K_x, K_y$ . Momentum of elect at S =  $P_s$  at T is  $P_T$  times  $t_s, t_T$ .

Call  $P_f = P_s + K_x$ .  $P_g = K_x - P_T$ .  $E_f = \sqrt{\mu^2 + P_f^2}$ .  
 $= P_T - K_y$   $= -K_y - P_s$   $E_g = \sqrt{\mu^2 + P_g^2}$

We get for the first term  $(T|A_y) (+|A_x|S) e^{-iE_f(t_T-t_x)} e^{-iE_g(t_T-t_y)} e^{-iE_s(t_x-t_s)}$   
 $\pm$  matrix element for + energy state.

second term  $-(T|A_x) (-|A_y|S) e^{-iE_f(t_T-t_x)} e^{-iE_g(t_T-t_y)} e^{-iE_s(t_y-t_s)}$   
 $\pm$  matrix element for - energy state.

The minus sign on the last term arises as a result of the properties of  $\psi(y,x)$ . In ordinary theory it is interpreted that at x a pair is created, a hole is made in sea, electron going to T, while hole is filled by electron S. This represents an exchange (relative to the first process where same electron S gets to T) of electron S & sea electron so by exclusion principle gets with neg. amplitude.

according to present theory state T and S might be the same in  $t_x$  term.  $\psi$  and theory says no. because then at times between  $t_y, t_x$  can't have same electrons in same state. We say it is same electron so Pauli exclusion doesn't operate. Old theory has such a term anyway, for it contemplates pairs created by x annihilated by Y (use. polarization type), one of which is excluded if electron is in state S - namely the pair created at x (& destroyed at Y) whose electron is in S. So term is subtracted relative to (infinite) vacuum of electron is at S. This is same term as we have so both theories give same result here.

FIG. 16. From Feynman's (1947g) notes on the "Theory of Positrons."

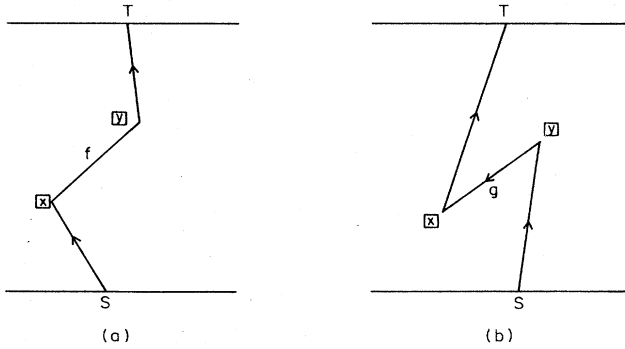

FIG. 17. Two diagrams from Feynman's notes on the theory of positrons. "The first represents scattering at  $x$ , followed by that at  $y$ . The second represents a pair created at  $x$ , the positron of which annihilates electron at  $y$ , and the electron of which is found at  $T$ " (Feynman, 1947g).

Upon comparing the contribution of these two terms with those obtained from hole-theoretic perturbation theory, Feynman found that the contribution from diagram (b) of Fig. 17 correctly incorporated a minus sign which in hole theory was accounted for by the contribution of the diagram indicated in Fig. 18.

Feynman (1947g) explained the result as follows:

The minus sign on the last term arises as a result of the properties of  $\mathcal{S}(y,x)$ . In ordinary theory it is interpreted that at  $x$  a hole is made in sea, electron going to  $T$ , while hole is filled by electron  $S$ . This represents an exchange (relative to the first process where same electron  $S$  gets to  $T$ ) of electron  $S$  and sea electron so by exclusion principle feeds with neg. amplitude.

According to the present theory state  $T$  and  $S$  might be the same in 2nd term. Usual theory says no because then at time between  $t_y$ ,  $t_x$  can't have 2 electrons in same state. We say it is the same electron so Pauli principle doesn't operate. Old theory has such a term anyway for it contemplates pair created by  $x$  annihilated by  $y$  (vac. polarization type) one of which is excluded if electron is in state  $S$ —namely the pair created at  $x$  (& destroyed at  $y$ ) whose electron is in  $S$ . So term is subtracted relative to (infinite) vacuum if electron is at  $S$ . This is same term as we have so both theories give same result here (Feynman, 1947g).

Feynman convinced himself of the validity of his for-

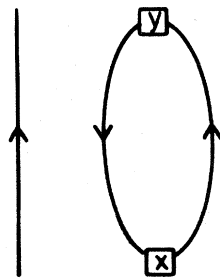

FIG. 18. The vacuum diagram that must be included in hole theory.

mulation by comparing its results with those obtained from hole-theoretic perturbation theory. There was no justification given—in late 1947—why "bubble diagrams" need not be considered. The fact that the "correct" expressions for the scattering amplitudes were obtained with the exclusion of "closed loops" reinforced Feynman's predilection that "closed loops" might not have to be considered.

In January of 1949, Feynman presented a paper at the New York meeting of The American Physical Society (Feynman, 1949a) entitled "The Theory of Positrons." His paper was the fifth one given at Session T of the meeting. Feynman had carefully prepared his talk, and a manuscript entitled "T5. Theory of Positrons" is to be found among his papers at the Millikan Library Archives (Feynman, 1948k). Although the paper was delivered in January 1949, its content reflects Feynman's thinking of one year earlier. The manuscript is of interest because it contains, besides the famous "bombardier" metaphor of his "Theory of Positrons" paper (Feynman, 1949b), other metaphors (including the one about the letter  $N$ ) to illustrate his notion of positrons as electrons moving backward in time.<sup>33</sup> It also gives us a glimpse of Feynman in a more philosophical vein.

After a brief historical sketch of Dirac's hole theory, Feynman elaborated:

One of the disadvantages of this [hole] theory is that even the simplest processes become quite complicated in its analysis. One must take into account besides the limited number of real particles, the infinite number of electrons in the sea. The present work results from a reinterpretation of the Dirac equation so that this complexity is not required.

It results from a different mode of representation of the phenomena of pair production. We can discuss it by a simple model. Suppose a black thread be immersed in a cube of collodion, which is then hardened. Imagine the thread, although not necessarily quite straight, runs from top to bottom. The cube is now sliced horizontally into thin square layers, which are put together to form successive frames of a motion picture. In each frame will

<sup>33</sup>The simile of "the space-time trajectory being like the letter  $N$ " is used in the introduction of "Theory of Positrons" (Feynman, 1949b). In that paper, the bombardier metaphor was stated as follows:

Following the charge rather than the particles corresponds to considering this continuous world line as a whole rather than breaking it up into pieces. It is as though a bombardier flying low over a road suddenly sees three roads and it is only when two of them come together and disappear again that he realizes that he has simply passed over a long switchback in a single road (Feynman, 1949b).

Feynman (1984a) recalls: "The 'bombardier metaphor' was suggested to me by some student at Cornell (who had actually been a bombardier during the war) when I was writing up my paper and was asking for opinions of how to explain it and only had poor or awkward metaphors."



appear a black dot, the cross section of the thread, which will move about in the movie depending on the waverings of the thread. The moving dot can be likened to a moving electron. How can pair production be visualized?

Suppose the thread did not go directly top to bottom but doubled back for a way (somewhat like the letter *N* with the straight parts extended to top and bottom). Then in successive frames first there would be just one dot but suddenly two new ones would appear when the frames come from layers cutting the thread through the reversed section. They would all three move about for a while when two would come together and annihilate, leaving only a single dot in the final frames. In this way new phenomena of pair creation and annihilation can be represented. They are similar to the simple motion of an electron (and are thus governed by the same equations), but correspond to a more tortuous path in space and time than one is used to considering.

In common experience the future appears to us to develop out of conditions of the present (and past). The laws of physics have usually been expressed in this form. (Technically, in the form of differential equations, or "Hamiltonian Form.") The formulae tell what is to be expected to happen if given conditions prevail at a certain time. The author has found that the relations are often very much more simply analyzed if the entire time history be considered as one pattern: The entire phenomena is considered as all laid out in the four dimensions of time and space, and that we come upon the successive events. This is applied to simplify the description of the phenomena of pair production in the present paper. A bombardier watching a single road through the bomb-sight of a low flying plane suddenly sees three roads, the confusion only resolving itself when two of them move together and disappear and he realizes he has only passed over a long reverse switchback of a single road. The reversed section represents the positron in analogy, which is first created along with an electron and then moves about and annihilates another electron.

The relation of time in physics to that of gross experience has suffered many changes in the history of physics. The obvious difference of past and future does not appear in physical time for microscopic events (the connection of the laws of Newton and of statistical mechanics). Einstein discovered that the present is not the same for all people. (For those in motion it corresponds to cutting the same collidion cube at slight angle from the horizontal.) It may prove useful in physics to consider events in all of time at once and to imagine that we at each instant are only aware of those that lie behind us.

The complete relation of this concept of physical time to the time of experience and causality is a physical problem which has not been worked out in detail. It may be that more problems and difficulties are produced than are solved by such a point of view. In the application to the description of positrons it should be emphasized that there still appear to be difficult unsolved problems and that the proposed viewpoint may eventually not prove to result in as much simplification as it appears to do at first sight (Feynman, 1948k).

The propagator  $\mathcal{S}$  was first introduced in the calculation of the self-energy. Feynman noted that the propagator defined as a sum over positive-energy states,

$$\mathcal{S}(2,1) = \sum_{\text{pos } E_n} \varphi_n(2)\bar{\varphi}_n(1)\exp[-iE_n(t_2-t_1)] \quad (5.33a)$$

for  $t_2 > t_1$ , and the negative sum over negative-energy states

$$- \sum_{\text{neg } E_n} \varphi_n(2)\bar{\varphi}_n(1)\exp[-iE_n(t_2-t_1)] \quad (5.33b)$$

for  $t_2 < t_1$ , yielded the correct hole-theoretic expression for the self-energy. Feynman recognized that the use of  $\mathcal{S}$  in place of the nonrelativistic propagator  $K_0$  and the replacement of  $\dot{x}_\mu$  by  $\gamma_\mu$  yielded the correct hole-theoretic results in perturbation theory. The "Theory of Positrons" notes of 1947 represent a formalization of these previously obtained results applied to the case of charged spin- $\frac{1}{2}$  particles in an external field.

Feynman confirms this. He recalls that the negative-energy states had always given him "trouble." He made a project imagining what would happen if an electron's space-time trajectory were like the letter *N* in time: "they would back up for a while and then go forward again . . ." and found that he obtained the right formulas for the "positron end of the cases" (Feynman, 1966b). He proceeded to make empirical rules about what sign should be given to particular terms, by doing more and more complicated problems and comparing the results with those of standard perturbation theory. He thus developed empirical rules for "computing every thing."

Diagrams evolved as a shorthand to help Feynman translate his integral-over-path perturbative expansions into the expressions for transition matrix elements being calculated.

In his interview with Charles Weiner, Feynman (1966b) remembered that

[It was when] I was working on the self-energy of the electron, and I was making a lot of these pictures to visualize the various terms and thinking about the various terms, that a moment occurred—I remember distinctly—when I looked at these, and they looked very funny to me. They were funny-looking pictures. And I did think consciously: Wouldn't it be funny if this turns out to be useful, and the *Physical Review* would be all full of these funny-looking pictures? It would be very amusing.

Feynman repeated these remarks in 1980. He then recalled while drawing diagrams "fantasizing," and saying to himself, "Wouldn't it be funny if these diagrams were to become really useful" (Feynman, 1980b).

## E. Renormalization

The quantum electrodynamics of Dirac (1927) and Heisenberg and Pauli (1929,1930) had been very successful in describing experimental phenomena to lowest order in  $e^2/\hbar c$ . Higher-order corrections, however, gave rise to infinite divergent integrals (Weinberg, 1977). For example, the attempt to calculate the shift in the energy of an electron in a Coulomb field due to the reaction on the electron of the electromagnetic field led to an infinite

answer (Oppenheimer, 1930). Even a free electron received an infinite correction,  $\delta m$ , to its rest energy, so that it would appear to have an infinite electromagnetic mass. In a consistent, finite theory the experimentally observed mass  $m_{\text{expt}}$  should be equal to the "mechanical" mass  $m_{\text{mech}}$ , the mass that is put into the equation of motion of the electron, plus the correction  $\delta m$ ,  $m_{\text{expt}} = m_{\text{mech}} + \delta m$ . (There is of course no experimental way to determine how much  $m_{\text{expt}}$  is  $m_{\text{mech}}$ .)

It is clear that if the electron has an infinite correction to the mass, other difficulties arise. For example, the energy of the ground state of hydrogen becomes  $\frac{1}{2}(m_{\text{mech}} + \delta m)e^4/\hbar^2 + \dots$ . Similarly one would expect that the corrections to Rutherford scattering would result in a cross section that vanishes, since no deflection is expected by an electron of infinite inertia.

It was Kramers's insight to note that if the single difficulty of the infinite self-energy of a free electron could be surmounted, all the other problems of the quantum electrodynamics of nonrelativistic charged particles would be solved at the same time. When Bethe (1947) calculated the Lamb shift, he assumed that it was due to the reaction of the electron to its own electromagnetic field. By comparing the divergent integrals he had calculated for an electron in a Coulomb field with those obtained in calculating the self-energy of a free electron, he was able to identify the divergent terms that were giving rise to the simple effect  $m_{\text{expt}} = m_{\text{mech}} + \delta m$ . These he discarded, because they had already been included when using  $m_{\text{expt}}$  instead of  $m_{\text{mech}}$  in calculating the Rydberg. Bethe argued that the remaining terms would be finite in a relativistic theory and obtained a value of about 1000 megacycles for the shift (after introducing appropriate cutoffs). Bethe's calculation suggested that Kramers's method might be general: all such divergences would be removed by renormalizing the mass.

The difficult problem of determining in an unambiguous manner which terms represented this mass effect in a fully relativistic treatment of quantum electrodynamics was first solved by Schwinger (1948b). He cast quantum field theories into a form in which the relativistic invariance of the terms was transparent. This reformulation had previously been independently invented by Tomonaga (1943,1946). From the clues suggested by the invariance properties of various terms, Schwinger was able to argue the elimination of certain divergent integrals in quantum-electrodynamic calculations because they represented *unobservable* mass and charge renormalizations (Schwinger, 1948b,1949a,1949b).

Feynman tried to solve these problems in a different way. He assumed that the laws of electrodynamics were altered at very short distances (or more precisely, at short proper times). The result of this modification is to produce a finite, relativistically invariant answer to all problems in quantum electrodynamics, including the rest mass of an electron. The value of the mass correction  $\delta m$  depends on the type of alteration that is made [i.e., on the form of the function  $f$  in Eq. (5.11)]. It depends logarithmically on the short distance  $a$  at which the effect of the

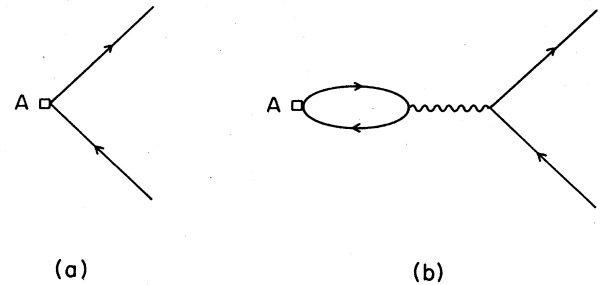

FIG. 19. (a) Contribution to lowest order to the scattering by the external potential. (b) Vacuum polarization effects to order  $e^2/\hbar c$  arising from diagram (b).

modification becomes appreciable. All other processes also depend in this way on  $a$  if expressed in terms of the mechanical mass  $m_{\text{mech}}$ . However, when expressed in terms of the experimental mass  $m_{\text{expt}}$ , they are very insensitive to the exact value of  $a$ , if  $a$  is much less than the electron Compton wavelength. In fact, there is a definite limit for all observable processes as the cutoff length goes to zero. It was in this manner that Feynman computed the Lamb shift and the other results described in his letters to the Corbens (Feynman, 1948d,1948e) and in his article "Relativistic Cut-Off for Quantum Electrodynamics" (Feynman, 1948b). Vacuum polarization processes, however, could not be made finite by altering photon propagators. Vacuum polarization effects (to order  $e^2/\hbar c$ ) arise because the potential, instead of scattering a charged particle directly [Fig. 19(a)], can do so by first creating a pair which subsequently annihilates, creating a photon that does the scattering [Fig. 19(b)]. The contribution from Fig. 19(b) is divergent. How to cut off (and therefore circumvent) this divergence in a *gauge-invariant* fashion gave Feynman a great deal of difficulty until the beginning of 1949. (His views regarding vacuum polarization will be presented in Sec. VII.) What he knew in early 1948 (Feynman, 1948b,1948f) was that the divergent part of the correction from Fig. 19(b) had the same structure as the contribution from Fig. 19(a) and that their sum could be interpreted as though the potential were of another strength. Equivalently, if one thinks of the potential as being created by a charge, one can introduce a bare charge  $e_{\text{bare}}$ , which appears in the equation of motion, and define  $\Delta e$  as the correction from Fig. 19(b). The "experimental" charge  $e_{\text{expt}} = e_{\text{bare}} + \Delta e$  defines a charge "renormalization"<sup>34</sup> in a manner analogous to mass renormalization. All observable quantities are finite when expressed in terms of  $e_{\text{expt}}$ .

Where matters stood in the spring of 1948 can be inferred from Feynman's lecture at the Pocono conference, which took place from 30 March to 1 April 1948. It is to this presentation that we now turn.

<sup>34</sup>Such a charge renormalization was already carried out by Dirac (1933) in the first paper dealing with the phenomenon.

VI. THE POCONO CONFERENCE

Feynman's (1948f) presentation of his "Alternative Formulation of Quantum Electrodynamics" at the Pocono conference<sup>35</sup> followed Schwinger's extended exposition of his version of QED, which had lasted well into the afternoon. In after-dinner remarks, on the occasion of Schwinger's 60th birthday, Feynman recalled the meeting:

Each of us [Schwinger and I] had worked out quantum electrodynamics and we were going to describe it to the tigers. He described his in the morning, first, and then he gave one of these lectures which are intimidating. They are so perfect that you don't want to ask any questions because it might interrupt the train. But the people in the audience like Bohr, and Dirac, Teller, and so forth, were not to be intimidated, so after a bit there were some questions. A slight disorganization, a mumbling, confusion. It was difficult. We didn't understand everything, you know. But after a while he got a good thing. He would say, "perhaps it will become clearer if I proceed," so he continued . . . (Feynman, 1978).

While Schwinger was lecturing, Bethe had noted that no one in the audience was giving him any difficulty as long as his presentation was formal and mathematical. However, as soon as he lapsed into a physical argument, he would be interrupted and heated discussions would ensue. Bethe therefore advised Feynman to present his formalism "mathematically" rather than "physically" (Feynman, 1966b). This Feynman proceeded to do with dismal consequences.

Feynman was prepared to present "this whole thing backward . . . not formally . . . with all physical ideas starting from path integrals" (Feynman, 1980b). Instead he gave a presentation that emphasized the mathematical aspects based on a formalism that was totally unfamiliar to his audience. "I had too much stuff," Feynman points out. "My machines came from too far away." And so he felt that his lecture was a complete failure, "a hopeless presentation" (Feynman, 1980b).

Feynman began his exposition of his formulation of quantum electrodynamics with an outline of his calculus of ordered operators:

A formal solution of the time-dependent Schrödinger equation may be written

$$\psi(x, t) = e^{-\frac{i}{\hbar} H t} \psi(x, 0), \tag{6.1}$$

when the operator  $H$  does not depend explicitly on time, or as

$$\psi(x, t) = e^{-\frac{i}{\hbar} \int_0^t H(t') dt'} \psi(x, 0) \tag{6.1'}$$

where the Hamiltonian  $H$  may depend on time.

If there be a perturbing potential  $V(t)$ ; i.e., the new Hamiltonian is  $H + V(t)$ , we have

$$\psi(x, t) = e^{\frac{i}{\hbar} \left[ \int_0^t H(t') dt' + \int_0^t V(t') dt' \right]} \psi(x, 0), \tag{6.2}$$

and this leads to the usual quantum-mechanical perturbation theory.

Feynman had devised a calculus to handle situations in which the order of the operators is of importance, and was thus able to give meaning to formal solutions such as the right-hand side of Eq. (6.1') and (6.2). The calculus was based on a simple notational device whereby the operators are given labels that indicate the order in which they are to be applied. Thus  $A_2 B_1 \psi$  means  $B$  acts first on  $\psi$ , then  $A$ , that is  $A_2 B_1 \psi = AB$  since the labels keep track of the order. Similarly  $B_2 A_1 \psi = BA \psi$ .

To determine the solution  $\psi(t)$  at  $t = T$  of  $i\hbar \partial_t \psi(t) = H(t) \psi(t)$  given  $\psi(0)$  at  $t = 0$ , break up the interval from 0 to  $T$  into  $n$  steps of length  $\Delta t$  over each of which  $H(t)$  is nearly constant. Then clearly

$$\begin{aligned} \psi(T) &= e^{-iH(t_n)\Delta t} e^{-iH(t_{n-1})\Delta t} \dots e^{-iH(t_1)\Delta t} \psi(0) \\ &= \prod_{i=1}^n e^{-iH(t_i)\Delta t} \psi(0). \end{aligned} \tag{6.3}$$

The order in which the various  $H(t_i)$  are to operate is specified by the value  $t_i$ , so that those with smaller  $t_i$  act on  $\psi$  before those with large  $t_i$ : the  $H(t_i)$  are ordered operationally as they are ordered temporally. Hence in the limit as  $\Delta t \rightarrow 0$ , the solution can be written in the form

$$\psi(T) = \exp \left[ -i \sum_{i=1}^n H(t_i) \Delta t_i \right] \psi(0) \tag{6.4}$$

$$= \exp \left[ -i \int_0^T H(t) dt \right] \psi(0), \tag{6.5}$$

where this last expression is to be interpreted in terms of the operational symbolism.

Applying this formalism to the Dirac equation in an external field  $A_\nu(x)$ ,

$$\gamma_\nu \left[ i\hbar \partial_\nu - \frac{e}{c} A_\nu \right] \psi = m \psi, \tag{6.6}$$

Feynman defined

$$\psi(x, w) = \exp \left[ + \frac{i}{\hbar} \int_0^w \left[ i\hbar \not{\partial}_{w'} - \frac{e}{c} A_{w'} \right] dw' \right] \psi(x, 0), \tag{6.7}$$

where  $x$  stands for the coordinates  $xyzt$  of the particle and  $w$  is a parameter. The right-hand side of Eq. (6.7) is understood in the notation of the ordered calculus, i.e., the  $\gamma$ 's, the  $\partial/\partial x_\nu$ , and the  $A_\nu(x(w))$  have a label attached to them which orders sequentially their operation on  $\psi(x, 0)$ . The so defined  $\psi(x, w)$  satisfies the equation

<sup>35</sup>J. A. Wheeler took notes at the Pocono conference, which he then prepared "informally and unofficially" and which were issued on 2 April as "Conference on Physics. Pocono Manor, Pennsylvania 30 March-1 April 1948. Sponsored by the National Academy of Science." Feynman reported on the conference in the June 1948 issue of *Physics Today*.

$$-i\hbar \frac{\partial \psi(x,w)}{\partial w} = \left[ i\hbar \not{\nabla} - \frac{e}{c} \mathbf{A} \right] \psi(x,w). \tag{6.8}$$

Since the Dirac equation for a particle with a well-defined mass is given by Eq. (6.6), one must demand that

$$-i\hbar \frac{d\psi}{dw} = m\psi, \tag{6.9}$$

that is, that  $\psi$  be periodic in  $w$ :

$$\int_0^\infty e^{-imw} \psi(x,w) dw = \int_0^\infty dw e^{-imw} \exp \left[ + \frac{i}{\hbar} \int_0^w \left[ \frac{\hbar}{i} \not{\nabla}_{w'} - \frac{e}{c} \mathbf{A}_{w'} \right] dw' \right] \psi(x). \tag{6.11}$$

The right-hand side of Eq. (6.11) will then be a solution of the Dirac equation (6.6) for a particle with mass  $m$ . The integral in the right-hand side of (6.11)

$$\int_0^\infty dw \exp \left[ + \frac{i}{\hbar} \int_0^w \left[ i\hbar \not{\nabla}(w') - \frac{e}{c} \mathbf{A}(w') - m \right] dw' \right]$$

is the ordered operator representation of the Feynman propagator for a Dirac particle

$$\frac{1}{i \left[ i\hbar \not{\nabla} - \frac{e}{c} \mathbf{A} - m \right]} = \int_0^\infty \exp \left[ i \left[ i\hbar \not{\nabla}(w) - \frac{e}{c} \mathbf{A}(w) - m \right] \right] dw, \tag{6.12}$$

where the mass  $m$  is assumed to have a small negative imaginary part.<sup>36</sup> For a system of  $n$  Dirac particles, the ordered operator

$$\begin{aligned} \psi(x_1, \dots, x_n, w_1, w_2, \dots, w_n) = & \exp \left\{ + \frac{i}{\hbar} \sum_n \left[ - \int_0^{w_n} \left[ \frac{\hbar}{i} \not{\nabla}(w'_n) dw'_n - \int_0^{w_n} \frac{e}{c} \mathbf{A}(x(w'_n)) dw'_n \right] \right] \right. \\ & \left. - \frac{1}{2} \frac{i}{\hbar} \sum \frac{e_n e_m}{c} \int_0^{w_n} \int_0^{w_m} \gamma_\mu^{(n)}(w'_n) \gamma_\mu^{(m)}(w'_m) \delta_+ \{ [x_\mu^{(m)}(w'_m) - x_\mu^{(n)}(w'_n)]^2 \} dw'_m dw'_n \right\} \\ & \times \psi(w_1, x_2, \dots, x_n, 0, \dots, 0). \end{aligned} \tag{6.13}$$

The right-hand side of Eq. (6.13) is the generalization to the case of Dirac particles of Feynman's result for the elimination of the transverse photons in the expression for the transition amplitude. The first two terms in the exponential are the propagators for the particles in an exter-

$$\psi(x,w) = e^{+(i/\hbar)mw} \chi(x). \tag{6.10}$$

In other words, if Eq. (6.8) is taken as a new relativistic equation for a spin- $\frac{1}{2}$  particle, the physical solutions are those which are periodic in  $w$  and will then correspond to a particle with mass  $m$ . Hence if  $\psi(x,w)$  is any special solution of Eq. (6.8), a solution of (6.9) is obtained by finding

$$\exp \left[ - \frac{i}{\hbar} \int_0^t H(t') dt' \right]$$

in Eq. (6.3) thus corresponds to

$$\int_0^\infty dw_1 \cdots \int_0^\infty dw_n \exp \left[ \frac{i}{\hbar} \sum_n \int_0^{w_n} \left[ i\hbar \not{\nabla}(w'_n) - \frac{e}{c} \mathbf{A}(w'_n) - m \right] dw'_n \right].$$

Feynman then wrote down the analog of Eq. (5.20) for a system of charged Dirac particles interacting via the quantized electromagnetic field when no real photons are present, initially or finally. It is a formula for the wave function (considered as a function of the variables  $w_1, w_2, \dots, w_n$ ) at "time"  $w_1, \dots, w_n$  in terms of the wave function at "time"  $w_1, \dots, w_n = 0$ :

<sup>36</sup>Since

$$\frac{1}{x} = \lim_{\epsilon \rightarrow 0} \frac{i}{x + i\epsilon} = \int_0^\infty \exp[iw(x + i\epsilon)] dw.$$

nal field  $A$ , and the third term is the interaction action obtained from Eq. (5.21) when the velocity for the  $n$ th particle,  $\dot{x}_\mu^{(n)}$ , is replaced by the corresponding  $\gamma_\mu^{(n)}$  matrix. Equation (6.13) was essentially the *first* formula Feynman wrote down at Pocono. This same equation (6.13), integrated on both sides with

$$\int_0^\infty dw_1 e^{(-i/\hbar)mw_1} \cdots \int_0^\infty dw_n e^{(-i/\hbar)mw_n}$$

so as to yield wave functions for Dirac particles of mass  $m$ , is the *last* formula in Feynman's *concluding* paper on quantum electrodynamics [Eq. (75) in Feynman (1951a);

see also footnote 19 of that paper]. It is derived there starting from the conventional formulation of quantum electrodynamics and can be considered the culmination and encapsulation of his formalism.

At Pocono, however, Feynman did not have a "complete formal derivation" for Eq. (6.13).

Feynman recalls Dirac's interrupting him and asking him "Is it unitary?" as he was explaining "how [he] was going to work out positrons and so on" (Feynman, 1978). Feynman remembered Schwinger's trick and said "Perhaps it will become clear as we proceed." "But Dirac was not put off, and like the Raven kept saying, 'Is it unitary?'" (Feynman, 1978). Not being quite sure what

Dirac meant, Feynman asked him is what unitary? To which Dirac answered "Is the matrix that carries you from the past to the future unitary?" Feynman was not clear what Dirac meant by "the matrix," nor what Dirac understood by unitary in connection with Eq. (6.13). "Since I have tracks going backwards and forwards in time I don't know whether it is unitary," was Feynman's reply. He muses that his answer was not quite satisfactory.

Feynman then considered the case of a free electron ( $A=0$ ) with "the goal . . . to find what is the permanent effect of the interaction" (Feynman, 1948f, pp. 48 and 49). To lowest order in  $e^2/\hbar c$

$$\psi(x,w) = \exp \left[ \frac{-i}{\hbar} \int_0^w \frac{\hbar}{i} \mathcal{V}(w) dw \right] \psi(x,0) + \exp \left[ -\frac{i}{\hbar} \int_0^w \frac{\hbar}{i} \mathcal{V}(w') dw' \right] \left[ \frac{e^2}{i\hbar c} \int_0^w dw' \int_0^{w'} dw'' \gamma_\mu(w') \gamma_\mu(w'') \delta_+(s_{w',w''}^2) \right] \psi(x,0). \tag{6.14}$$

The effect of the second term is proportional to the elapsed time. If it corresponds to a change in mass from  $m$  to  $m + \delta m$  it will be proportional to

$$+ i w e^{(i/\hbar) w m} \delta m \psi(w,0)$$

and hence

$$e^{(i/\hbar) w m} \delta m = \frac{i\hbar}{w} \left[ \exp \left[ -\frac{i}{\hbar} \int_0^w \mathcal{V}(w') dw' \right] \right] \frac{e^2}{i\hbar c} \int_0^w \int_0^{w'} dw' dw'' \gamma_\mu(w') \gamma_\mu(w'') \delta_+(s_{w',w''}^2). \tag{6.15}$$

Upon writing

$$\int_0^w = \int_0^{w'} + \int_{w'}^{w''} + \int_{w''}^w, \tag{6.16}$$

ordering the terms according to their chronological parameter, and carrying out the integrations, Feynman obtained the result

$$\delta m = \int \frac{\gamma_\mu(\not{p} + \not{k} + m) \gamma_\mu}{p^2 + k^2 - (m - i\epsilon_1)^2} \frac{d\omega_k}{k^2 - i\epsilon_2}, \tag{6.17}$$

$$d\omega_k = \frac{dk_4 dk_3 dk_2 dk_1}{2\pi^2 i}$$

which "is the standard formula for the self-energy" (Feynman, 1948f, p. 50). It diverges logarithmically. Upon introducing his cutoff, i.e., replacing the  $\delta_+$  function by

$$f_+(s^2) = \int e^{-ik_\mu x_\mu} \frac{d\omega_k}{k^2 - i\epsilon} \times \int_0^\infty \frac{-\lambda^2}{k^2 - \lambda^2} G(\lambda) d\lambda, \tag{6.18}$$

where  $\int_0^\infty G(\lambda) d\lambda = 1$ , Feynman concluded that  $\delta m$  is finite but depends logarithmically on the cutoff,

$$\delta m = m \left[ \frac{3}{2} \ln(\lambda/m) - \frac{1}{2} \right]. \tag{6.19}$$

Feynman also indicated the equivalence of his approach

to the conventional one. He derived the usual expression for the self-energy from Eq. (6.17) by integrating over  $k_4$ , the location of the poles being stipulated by the  $i\epsilon$  factors.

Next Feynman pointed out that the term which arises in the discussion of the self-energy,

$$\int \gamma_\mu \frac{\not{p} + \not{k} + m}{(p^2 + k^2) - (m - i\epsilon)^2} \gamma_\mu \frac{d\omega_k}{k^2},$$

is the Fourier transform of

$$\bar{\psi}(2) \gamma_\mu f_+(2,1) S_+(2,1) \psi(1),$$

in which  $S_+(2,1)$  is the amplitude for arrival at 2 of an electron given out at 1,  $f_+(2,1)$  is the electromagnetic disturbance at 2 due to charge at 1 and that this term could be represented diagrammatically as indicated in Fig. 20. Feynman then gave an exposition of his theory of positrons, as outlined in the notes previously referred to in Sec. V.D. The diagrams to be found in these notes were used to illustrate the difference between Feynman's and Dirac's hole theory. Feynman stressed that his formalism was rooted in an approach that computed transition amplitudes where the data is specified at time 0 and time  $T$ :

We cannot find the amplitude for a negaton to be at  $x$  merely by knowing the amplitude for the negaton to be

at a previous time; we have also to know the amplitude for a positron to be at a later time.<sup>37</sup>

Feynman went on to explain how in his formalism one could disregard the Pauli exclusion principle in intermediate states. At this point Teller interrupted him and inquired: "You mean that helium can have three electrons in the *S* state for a little while?" To which Feynman replied: Yes. "That was chaos," Feynman (1978) recalls. The notetaker recorded "The Exclusion Principle Comes Out Automatically" and also noted that

Bohr Has Raised The Question As To Whether This Point Of View Has Not The Same Physical Content as The Theory Of Dirac, But Differs In A Manner Of Speaking Of Things which Are Not Well-Defined Physically (Wheeler, 1948, p. 52).

Feynman then asserted that the effect of an external electromagnetic field could be included by taking the propagator in the transition amplitude to be

$$\exp \left[ \frac{i}{\hbar} \left( -\frac{\hbar}{i} \int \mathcal{V}_w dw - \frac{e}{c} \int \mathcal{A}(w) dw + \frac{e^2}{c} \int \int \gamma_\mu(w') \gamma_\mu(w'') f_+(s_{w'w''}^2) dw' dw'' \right) \right]. \quad (6.20)$$

To lowest order in the external field, and to order  $e^2/\hbar c$  three terms contribute. The "straddle or central term" for the transition between states  $\psi_2$  and  $\psi_1$  was shown by Feynman to be given by

$$\int \gamma_\mu \frac{1}{\not{p}_2 + \not{k} - m} \gamma_\nu \frac{1}{\not{p}_1 + \not{k} - m} \gamma_\mu \frac{d\omega_k}{k^2}.$$

Transformed to coordinate space it corresponded to

$$\bar{\psi}(2) \gamma_\mu S_+(3,2) \mathcal{A}(2) S_+(2,1) \gamma_\nu \psi(1) f_+(3,1)$$

and could be represented by the diagram in Fig. 21(a). This term diverges without the cutoff (i.e., with  $\delta_+$  instead of  $f_+$ ). Upon the inclusion of two self-energy terms [Figs. 21(b) and 21(c)], the three terms combine to give a finite answer. "No convergence factor is needed" (Feynman, 1948f, p. 55). The notes give an expression for the vertex function. They also report the results of Feynman's computation for the contributions to the Lamb shift of this radiative correction: 1000 Mc (as compared to 1050 Mc for Schwinger).

Feynman's calculation did not include closed loops—"paths which give rise to infinite polarizability of vacuum." The notes report that "Feynman Believes It Possible To Get A Consistent Theory Without Using Loops" (Feynman, 1948f, p. 55). The report on Feynman's lec-

<sup>37</sup>Pocono conference notes, p. 53. Wheeler, who was the note taker, was trying to conform to the recommendation of the International Union of Physics by calling electrons the generic name of particles with the mass of an electron and charge  $\pm e$ , and giving the name negaton to a negatively charged electron and positon to the positively charged antiparticle.

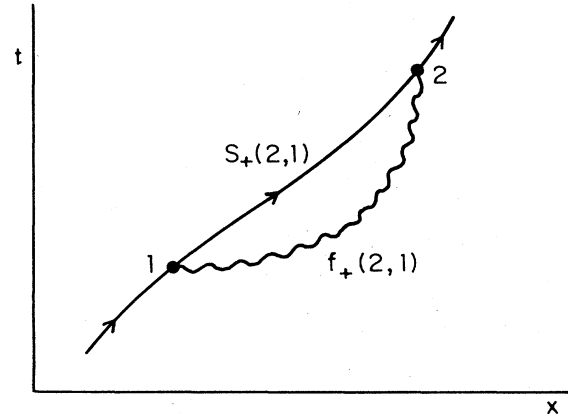

FIG. 20. Self-energy diagram as drawn in Wheeler's Pocono notes.

ture closes with the remark "Still To Be Investigated in This New Feynman Theory Is the Scattering of Light by Light."

Feynman deemed his lecture at the Pocono conference a failure. On the day he received the announcement that he had received the Nobel Prize, Feynman gave an inter-

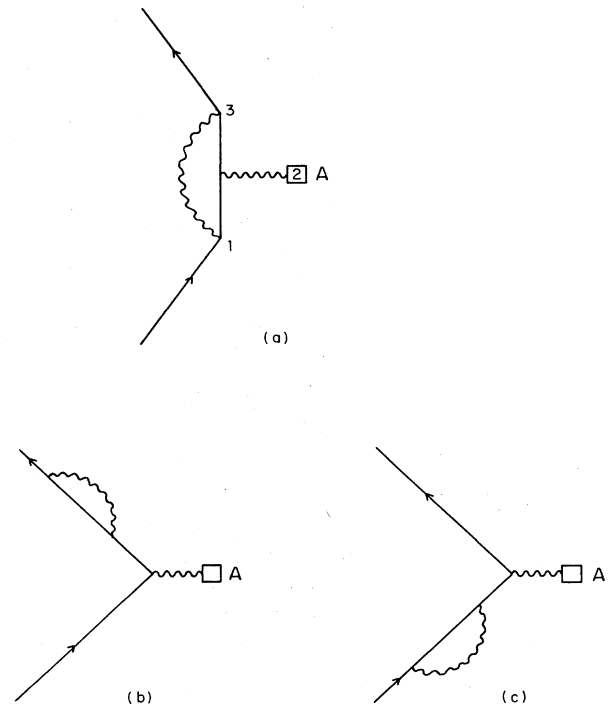

FIG. 21. (a) The vertex diagram to order  $e^2/\hbar c$  and lowest order in the external field. (b),(c) The self-energy terms to order  $e^2/\hbar c$ .

view to the *California Tech*, the student newspaper at Caltech. That article gave the following account of the Pocono conference:

Schwinger went first, giving a very mathematical presentation of his methods; whenever he tried to give a physical example, the audience threw so many questions at him that he postponed the example and went back to the math. Then Feynman came to bat. His [Feynman's] ideas were greeted with even less enthusiasm [than Schwinger's], largely because field theory was then in vogue and his theory relied upon particle analysis. He found it very difficult to explain his formulations because they relied heavily upon physical arguments and intuition.

At each step he was asked to justify his procedure; instead he offered to work out a physical example to demonstrate the correct results it produced. But the audience objected to the time this would require and the hair involved, even though these had been drastically reduced by his methods. The culmination of his audience's feeling that Feynman was running amok without being rigorous came when Niels Bohr stood up, objected to Feynman's use of trajectories for small particles, and started reminding him about Heisenberg's uncertainty principle. Here Feynman gave up in despair, realizing that he couldn't communicate the fact that his analysis was justified by its correct results.

Feynman then decided to publish what he had so far, without waiting to remove completely the divergence difficulties, as he had originally planned. It turned out to be a good idea, because the difficulties have yet to be removed, even after 17 years (Feynman, 1965).

Feynman (1966b) also talked about the reception of his lecture at Pocono in his interview with Charles Weiner. He there recounted that Bohr's objection was that his use of trajectories was not "a legitimate idea in quantum mechanics." Bohr reminded him that it was realized "already in the early days of quantum mechanics" that the uncertainty principle rendered the "classical idea of a trajectory" invalid. Feynman also recalled that later Bohr had come up to him and apologized. His son, Aage, had told him that he had misunderstood what Feynman was saying and that in fact Feynman's viewpoint "was consonant with the principles of quantum mechanics" (Feynman, 1966b). To Charles Weiner Feynman (1966b) gave the impression that although he was somewhat discouraged by the criticisms that had been expressed during his talk—*re* unitarity, the Pauli principle in intermediate states, the use of space-time trajectories—he was not "unhappy from that"; he was merely resigned and felt that he had to publish. His interview with the *California Tech* probably gave a more accurate picture. He did give up in "despair." Bethe also remembers that "Feynman was quite despondent" and that he had lots of talks with him after Pocono to reassure him "that he [Bethe] believed him to be right" (Bethe, 1980).

There is one further aspect of the Pocono conference that Feynman has stressed (Feynman, 1966b, 1978, 1980b, 1985b). Feynman recounts that after he had finished his talk

[Schwinger and I] got together in the hallway and although we'd come from the ends of the earth with different ideas, we had climbed the same mountain from different sides and we could check each other's equations.

I must explain [that] our methods [Schwinger's and mine] were entirely different. I didn't understand about those creation and annihilation operators. I didn't know how these operators that he was using worked, and I had some magic from his point of view.

We compared our results because we worked out problems and we looked at the answers and kind of half described how the terms came. He would say, well I got a creation and then an annihilation of the same photon and then the potential goes . . . . Oh, I think that might be that, [and] I'd draw a picture. He didn't understand my pictures and I didn't understand his operators, but the terms corresponded and by looking at the equations we could tell, and so I knew, in spite of being refused admission by the rest, by conversations with Schwinger, that we both had come to the same mountain and that it was a real thing and everything was all right (Feynman, 1978).

Feynman also indicates that

We discussed matters at Pocono and later also over the telephone and compared results. We did not understand each other's method but trusted each other to be making sense—even when others still didn't trust us. We could compare final quantities and vaguely see in our own way where the other fellow's terms or error came from. We helped each other in several ways. For example, he showed me a trick for integrals that led to my parameter trick, and I suggested to him that only one complex propagator function ever appeared rather than his two separate real functions. Many people joked we were competitors—but I don't remember feeling that way (Feynman, 1985b).

## VII. THE FINISHING TOUCHES

### A. Vacuum polarization

Aage Bohr, who attended the Pocono conference, recalls that

Feynman (who after Schwinger's lengthy review was left with rather little time to present his results) put a question mark on the need to include the vacuum polarization term, which appeared as a separate effect. This gave rise to criticism from many sides, and I think my father [Niels Bohr] also raised objections to this view. The way the meeting developed, therefore, had the unfortunate effect of leaving some of the audience with the impression that Feynman's approach was less complete than Schwinger's (A. Bohr, 1980).

The problem of vacuum polarization always played a special role in Feynman's approach. Closed loops, which were responsible for the vacuum polarization phenomena (Fig. 19), represented special paths—"unnatural" ones—in his integral-over-paths formalism:

From one point of view we are considering all routes by which a given electron can get from one region of space-time to another, i.e., from the source of electrons to the apparatus which measures them. From this point of view the closed-loop path leading to . . . [vacuum polarization] is unnatural. It might be assumed that the only paths of meaning are those which start from the source and work their way in a continuous path (possibly containing many reversals) to the detector. Closed loops would be excluded (Feynman, 1949c, p. 246).

Moreover, his successful reformulation of classical electrodynamics which excluded self-interactions had made a deep impression on him. Wheeler and Feynman's mechanism for radiation resistance—as stemming from the advanced interactions of the absorber particles with the charge emitting the radiation—had given him “a greater appreciation for the possibilities” (Feynman, 1980b): He was not convinced that the explanation given by conventional QED of vacuum polarization, the scattering of light by a potential or the scattering of light by light, was unique and the only way to describe these phenomena.

When Bethe's explanation of the Lamb shift convinced him that self-interactions must be allowed—at least in conventional QED—Feynman proceeded to derive a closed expression for the transition amplitude from which he could compute the radiative corrections to scattering by an external field. It was not immediately obvious from this expression where the processes that are mediated through closed loops in conventional QED came from. The reason for this was that he had generalized a nonrelativistic theory (in which the number of charged particles is conserved and no pair production occurs) to one where particles could be created by virtue of his positron-theory propagators. Moreover, in Feynman's (initial) formulation of his positron theory, disconnected diagrams did not occur. The Feynman propagator for a Dirac particle in an external field was given in a perturbative expansion as

$$S_{A+} = S_+ - \frac{i}{\hbar} S_+ A S_+ + \left[ -\frac{i}{\hbar} \right]^2 S_+ A S_+ A S_+ + \dots, \tag{7.1}$$

and no diagrams such as those indicated in Figs. 22(a) and 22(b) appeared. That reformulation of positron theory strengthened his skepticism about closed-loop effects. His theory of positrons—using his  $S_+$  propagator—automatically gave the correct perturbation-theory result



FIG. 22. (a) Bubble diagram to order  $(A)^2$ . (b) Bubble diagram to order  $(A)^4$ .

for the self-energy of an electron to order  $e^2/\hbar c$  by calculating the contribution of diagram (a) of Fig. 23 without having to invoke diagram (b), which had to be taken into account in a hole-theory calculation so that the correct contribution was obtained. In Feynman's original conception the vacuum was a simple structure.

Feynman of course knew the phenomena closed loops gave rise to in conventional QED: the Uehling effect, the scattering of light by light, etc. His letter to the Corbens in January of 1948 (Feynman, 1948d) indicated that, although he did not completely understand the problems connected with the polarization of the vacuum, he could compute finite but non-gauge-invariant answers. No progress was made over the next few months because, in March of 1948, he reiterated to the Corbens that “Polarization of the vacuum still remains somewhat of a puzzle” (Feynman, 1948e).

Already in his “Theory of Positrons” notes Feynman (1947k) had outlined how to calculate the polarization of the vacuum using his propagators. Feynman there wrote

Vac. Polariz  $t_{\nu\mu} = \text{Spur}(\mathcal{S}(2,1)\gamma_\nu \mathcal{S}(1,2)\gamma_\mu)$   
 assume each  $\mathcal{S}$  has different mass. Let us take  $q_\mu$   
 component of Fourier transform:

$$t_{\nu\mu} = \int \frac{\text{Spur}[\gamma_\sigma(p_\sigma + q_\sigma + m)\gamma_\nu[\gamma_\tau p_\tau + m]\gamma_\mu]}{[(p_\mu + q_\mu)^2 - m^2][p_\mu^2 - m_0^2]} dp \tag{7.2}$$

Numerator equals  $p_\nu(p_\mu + q_\mu) + p_\mu(p_\nu + q_\nu) - g_{\nu\mu}[p_\sigma(p_\sigma + q_\sigma) - m^2]$ .

The purpose of giving each propagator a different mass was to apply his cutoff method, or as Pauli was later to

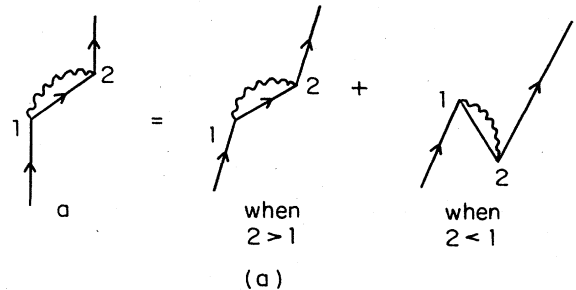

FIG. 23. (a) The self-energy diagram to order  $e^2/\hbar c$ . (b) The “vacuum” contribution.



call it, to "regularize" each  $\mathcal{S}$  separately. Although the method yielded a convergent answer, the result was not gauge invariant (Feynman, 1949c, p. 246 and footnote 20). Alternative ways to obtain gauge-invariant results were sought. In December 1949, writing to Wheeler, who had just informed him of his dispersion-theoretic approach to calculating the scattering of light by light (from the cross section for pair production in two-photon collisions), Feynman noted

I am very interested in the proposals that you have made with regard to the relation between absorption and dispersion, or in other words between real and virtual processes . . . . Professor Bethe suggested to me a couple years ago that all these problems of vacuum polarization, etc. could be studied by studying the real processes such as pair production to which they are related as absorption is to dispersion. The real processes represent the residues at the poles of some complex function. The virtual processes give the remainder of the description of the function, which should however be determined by the character of its poles. But neither of us has done anything in this direction and I would be very anxious to hear more details about your results (Feynman, 1949e).

At issue was not only techniques for calculating vacuum polarization effects gauge-invariantly, but the very reality of these effects. In his paper "Relativistic Cut-Off for Quantum Electrodynamics," submitted to the *Physical Review* on 12 July 1948 Feynman (1948b) asserted that "the real existence of such polarization corrections is, in the author's view, uncertain."

Freeman Dyson, who had gone to the Institute for Advanced Study after a year's residence at Cornell, visited Feynman in late October of 1948. Dyson had just finished writing his paper on "The Radiation Theories of Tomonaga, Schwinger, and Feynman," proving the equivalence of Feynman's approach to that of Schwinger (Dyson, 1949a). On this trip to Cornell, he was accompanied by Cecile Morette. Dyson's account of his journey is related in a letter to his parents written shortly thereafter:

Feynman himself came to meet us at the station, after our 10-hour train journey, and was in tremendous form, bubbling over with ideas and stories and entertaining us with performances on Indian drums from New Mexico until 1 a.m.

The next day, Saturday, we spent in conclave discussing physics. Feynman gave a masterly account of his theory, which kept Cecile in fits of laughter and made my talk at Princeton a pale shadow by comparison. He said he had given a copy of my paper to a graduate student to read, then asked the student if he himself ought to read it. The student said "No" and Feynman accordingly wasted no time on it and continued chasing his own ideas. Feynman and I really understand each other; I know that he is the one person in the world who has nothing to learn from what I have written; and he doesn't mind telling me so. That afternoon, Feynman produced more brilliant ideas per square minute than I have ever seen anywhere before . . . .

In the evening I mentioned that there were just two problems for which the finiteness of the theory remained

to be established; both problems are well-known and feared by physicists, since many long and difficult papers running to 50 pages and more have been written about them, trying unsuccessfully to make the older theories give sensible answers to them. Amongst others, Kemmer and the great Heisenberg had been baffled by these problems.

When I mentioned this fact, Feynman said "We'll see about this," and proceeded to sit down and in two hours, before our eyes, obtain finite and sensible answers to both problems. It was the most amazing piece of lightning calculation I have ever witnessed, and the results prove, apart from some unforeseen complication, the consistency of the whole theory.

The two problems were, the scattering of light by an electric field, and the scattering of light by light.

After supper Feynman was working until 3 a.m. He has had a complete summer of vacation, and has returned with unbelievable stores of suppressed energy.

On Sunday Feynman was up at his usual hour (9 a.m.) and we went down to the Physics building, where he gave me another 2-hour lecture on miscellaneous discoveries of his . . . (Dyson, 1948).

However, a week later Feynman was to write Dyson

I hope you did not go bragging about how fast I could compute the scattering of light by a potential because on looking over the calculations last night I discovered the entire effect is zero. I am sure some smart fellow like Oppenheimer would have known such a thing right off.

Any loop with an odd number of quanta in it is zero. This is because among the various possibilities which must be summed there is one corresponding to the electron going around one way and another with the electron progressing around the loop in the opposite direction. The latter is the same as the former with reversal of the sign of the charge, thus all quanta and potential interactions change sign, so if there is an odd number of them the total result is zero (Feynman, 1948g).

Feynman summarized the situation in the late fall of 1948 in a letter to his friend Ted Welton:

In regard to "Q.E.D." as you put it, I don't have the cold dope. I can calculate anything, and everything is finite, but the polarization of the vacuum is not gauge-invariant when calculated. This is because my prescription for making the polarization integrals convergent is not gauge-invariant. If I threw away the obvious large gauge dependent term (a procedure which I can not justify legally, but which is practically un-ambiguous) the result is a charge re-normalization plus the usual Uhling term. The amount of charge renormalization depends logarithmically on the cutoff. The Uhling terms are practically independent of the cutoff and give the usual  $-1/5$  in the Lamb shift.

These terms come from closed loops (in my way of talking, which I think you understand), in which two quanta are involved. Loops with a higher number of quanta always converge and in fact give definite answers practically independent of the cut-off, so that they could be computed by conventional Q.E.D. Incidentally, it is easy to show that all loops with an odd number of quanta of field interactions give zero. You know about these things. It is widely known that scattering of light by a potential only occurs with completed second order in the

potential, i.e., probably fourth order in the potential. I think you told me it was so some time ago.

To me it has become clear that all the problems of Q.E.D. appear to be involved in the simplest problems, (self-energy and vacuum polarization) the more complicated ones always converge (Feynman, 1948j).

The last point was of course the thrust of Dyson's paper, and presumably had been expounded to Feynman by him on his visit.

Thus by the end of 1948, Feynman had the following results regarding closed loops: the divergent lowest-order bubble diagrams—the ones that occurred in the self-energy of the photon and the Uehling effect, Figs. 24(a) and 24(b)—could not be cutoff in a gauge-invariant way. All higher-order closed-loop effects—such as the one giving rise to the scattering of light by light—(Fig. 25) were finite.

At the end of January 1949, Bethe received a communication from Pauli (1949b) with an important enclosure: a lengthy letter (“which became more similar to a smaller paper than to an ordinary letter”) which Pauli had written to Schwinger (Pauli, 1949a). In this “small paper” Pauli outlined his method of regulators, by which he gave “definitional meaning” to the singular integrals encountered in Schwinger's approach.<sup>38</sup> In particular, he indicated that the vacuum polarization divergence could be given a gauge-invariant regularization by calculating

$$t_{\mu\nu}^P = \int_0^\infty [t_{\mu\nu}(m^2) - t_{\mu\nu}(m^2 + \lambda^2)] G(\lambda) d\lambda, \quad (7.3)$$

where  $t_{\mu\nu}(m^2)$  is Eq. (7.2) with  $m_f^2 = m_0^2 = m^2$  and imposing on  $G(\lambda)$  the conditions satisfying  $\int_0^\infty G(\lambda) d\lambda = 1$  and  $\int_0^\infty G(\lambda) \lambda^2 d\lambda = 0$ .

Bethe reported this regularization method to Feynman, who adopted it. In Feynman's “Space-Time Approach to Quantum Electrodynamics” the self-energy of the photon and the divergent contribution to polarization of the vacuum are invariantly cut off using Pauli's regulator method. Feynman now knew how to circumvent the vacuum polarization difficulties, but his skepticism about the reality of closed-loop effects was not totally dispelled. In his “Space-Time Approach to Quantum Electrodynamics” he comments,

The closed loops are a consequence of the usual hole theory in electrodynamics. Among other things, they are required to keep probability conserved. The probability that no pair is produced by a potential is not unity and its deviation from unity arises from the imaginary part of  $J_{\mu\nu}$  [what was called  $t_{\mu\nu}$  above in Eq. (7.2)]. Again, with closed loops excluded, a pair of electrons once created cannot annihilate one another again, the scattering of light by light would be zero, etc. Although, we are not experimentally sure of these phenomena, this does seem to indicate that the closed loops are necessary (Feynman, 1949c, p. 779).

<sup>38</sup>The method is known as the Pauli-Villars method and is described in Pauli and Villars (1949).

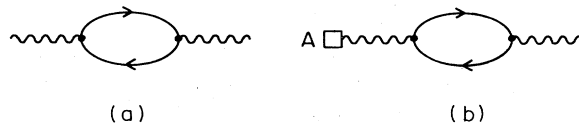

FIG. 24. (a) The photon self-energy diagram. (b) Vacuum polarization diagram.

And in a footnote Feynman added,

It would be very interesting to calculate the Lamb shift accurately enough to be sure that the 20-megacycles expected from vacuum polarization are actually present (Feynman, 1949c, footnote 18).

Settling this issue was of great interest and importance to Feynman, and he actively participated in the relativistic calculation of the Lamb shift (Baranger, Bethe, and Feynman, 1953). This was “getting the numbers out” and thereby checking the theory. Developing better calculational tools “to get the numbers out” was something Feynman could not leave alone: A good deal of the second half of 1948 was devoted to this enterprise. The Feynman rules were also extended to apply to spin-0 and spin-1 particles, and during the spring of 1949 the rules for the various meson theories were obtained. The appendixes of his “Space-Time Approach to Quantum Electrodynamics” attest to the success of those efforts.

## B. Evaluating integrals

Feynman spent part of the summer of 1948 in Albuquerque and Santa Fe. Dyson has told the story of the trip out west in *Disturbing the Universe* (Dyson, 1979, Chap. 6). In New Mexico, “where love had drawn” him, Feynman found “on arrival love dispersed” (Feynman, 1948g), so he returned to work on improving the efficiency of his computational methods. Using “ever newer & more powerful methods” he checked again the radiationless scattering, and found agreement with his previous results. In a letter to Bethe he indicated

I am the possessor of a swanky new scheme to do each problem in terms of one with one less energy denominator. It is based on the great identity

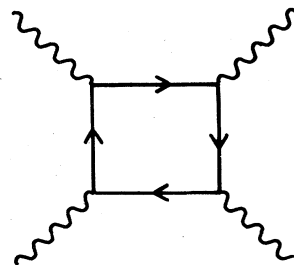

FIG. 25. Lowest-order diagram for the scattering of light by light.

$$\frac{1}{a \cdot b} = \int_0^1 dx \frac{1}{[ax + b(1-x)]^2}$$

so 2 energy denominators may be combined to one—reserving the parametric  $x$  integration to the indefinite future (there's the rub, of course) (Feynman, 1948g).

Feynman's cutoff replaced the photon propagator  $1/k^2$  by a new propagation kernel given by  $1/k^2 - 1/(k^2 - L)^2$ , which he now conveniently represented as an integral

$$\frac{1}{k^2} - \frac{1}{k^2 - \lambda^2} = - \int_0^{\lambda^2} \frac{dL}{(k^2 - L)^2} \quad (7.4)$$

Using his "swanky" integral representation for  $1/ab$  Feynman could then reduce all the integrations encountered in evaluating Feynman diagrams thus far to the following:

$$\int_{-\infty}^{+\infty} \frac{(1; k_\sigma) d^4k}{(2\pi)^4 (k^2 + i\epsilon - L)^3} = \frac{1}{32\pi^2 iL} (1; 0) \quad (7.5)$$

In Eq. (7.5) the notation  $(1; k_\sigma)$  means that either 1 or  $k_\sigma$  appears in the numerator, in which case on the right-hand side the  $(1; 0)$  is 1 or 0, respectively. The power of his new techniques were such that he believed he would be able to send Bethe the radiative corrections to the Klein-Nishina formula "in a few days." Also if Bethe "were vitally interested in corrections to Møller" Feynman thought he could deliver these "in short order (less than week?)."

Two weeks later, Feynman wrote Bethe from Santa Fe:

I have been working on the Compton effect & the few days I promised the answer in turned into weeks. There are lots of integrals & terms to be added all together etc. & I kept looking for a new & easy way because it was so complicated. But I think it is like calculating  $\pi$  to 107 decimal places—there is no short cut but to carry out the digits. So here I am beginning to believe that the answer is not much less simple than the steps leading to it—so I finally buckled down & did it . . .

I have set up & indicated how every integral can be reduced to transcendental integrals in one variable, exactly. But I haven't done all the work of putting all the pieces all together & writing down the answers. I have, however, worked out a special limiting case in detail . . . (Feynman, 1948h).

The rest of the year was spent working hard preparing materials for his two papers, "Theory of Positrons" and "Space-Time Approach to Quantum Electrodynamics." In late fall 1948 he informed Ted Welton, "I am very busy these days writing all my stuff on my paper . . . I am working like a demon" (Feynman, 1948j).

### C. The January 1949 APS meeting

The January 1949 meeting of The American Physical Society in New York proved to be another important landmark in Feynman's formulation of QED. As a result of a controversy between Slotnick and Case that Feynman got drawn into, he finally had to learn the formalism of second quantization. This proved to be of great value in writing up his "Theory of Positrons" and his subsequent papers (Feynman, 1950a, 1951a).

At the APS session dealing with nuclear scattering and neutron velocity spectrometer measurements, Rainwater, Rabi, and Havens reported on their recent measurements of the neutron-electron interaction as determined by the scattering of slow neutrons in lead and bismuth (Rainwater *et al.*, 1949). These experiments essentially measured the neutron's electric form factor (for zero momentum transfer), a quantity of considerable theoretical interest. Several calculations of the neutron form factor had been performed in the past using various meson theories with various couplings, but the results were always plagued by the canonical divergence difficulties.<sup>39</sup> More recently, Murray Slotnick (Slotnick and Heitler, 1949), in an impressive dissertation under Heitler and Bethe, had computed the interaction between a neutron and the electrostatic field of an electron in pseudoscalar meson theory. Although he had used old-fashioned computational methods, he had made use of renormalization techniques and had obtained expressions for the "equivalent interaction potential"<sup>40</sup> in pure charged and in symmetrical pseudoscalar meson theory for both pseudoscalar coupling and pseudovector coupling. The result for pseudoscalar coupling was finite—"7 keV for pure charged and -15 keV for the Symmetrical theory" (Slotnick 1949)—whereas for pseudovector coupling he had obtained a logarithmically divergent result.

Slotnick had submitted an abstract of his work for the APS meeting (Slotnick, 1949), and his presentation was scheduled to follow the paper of Rainwater, Rabi, and Havens.

Oppenheimer was in the audience, and after Slotnick's talk he commented that Slotnick's results must be wrong since they contradicted "Case's theorem." Oppenheimer pointed out that Case—who was a postdoctoral fellow at the Institute for Advanced Study—had just proved a theorem which stated that (to a certain approximation) pseudoscalar meson theories with pseudoscalar coupling were equivalent to ones with pseudovector coupling even in the presence of an external electromagnetic field. Since Slotnick's calculations violated "Case's theorem" they were in error. Case was due to give a paper the next day (Case, 1949a). Since Slotnick did not know of Case's work—no paper or preprint had yet appeared—he was at a loss to reply to Oppenheimer's pointed criticism.

When Feynman arrived in New York that evening he was told what had happened at the session. He received a report on the calculations of Slotnick, the "numbers" which he had obtained after long and laborious computations, and Oppenheimer's slashing criticism. He was then asked to comment on the validity of Slotnick's results in the light of "Case's theorem." Feynman had likewise not heard of Case's theorem. In fact, up to that point he had not interested himself in meson-theoretic calculations.

<sup>39</sup>See the references given in Slotnick and Heitler (1949).

<sup>40</sup>The value of  $\int V(x) d^3x$ , where  $V$  is the neutron-electron potential.

However, between the results of a person who had calculated "numbers" and those of a formalist the choice was clear. To corroborate his hunch that Slotnick was right, he got someone to explain to him what was meant by pure charged and symmetric meson theory, by pseudoscalar and pseudovector coupling, and readily translated this information into the rules to compute the relevant matrix elements using his methods. He spent a few hours that evening calculating the difference between the proton and neutron electric form factor in various meson theories with both pseudoscalar and pseudovector couplings. The next morning he got hold of Slotnick in order to compare his results with those that Slotnick had obtained, "because he wasn't quite sure that he had transcribed properly the usual formulation of meson theories into his rules" (Feynman, 1980b). When they compared their calculations Slotnick asked him what was the meaning of the  $q^2$  in Feynman's formulas. Feynman answered that it was the momentum transferred by the electron in the scattering. Feynman had calculated the full vertex function for arbitrary momentum transfer. "Oh," said Slotnick, "my results are only for  $q^2=0$ ." "That's OK," Feynman indicated. "I can readily take the  $q^2=0$  limit" (Feynman, 1966a, p. 706), which he proceeded to do and then compared his answer with Slotnick's. They agreed. Slotnick was flabbergasted. He had spent close to two years on the problem and over six months on a calculation that took Feynman one evening. Even though Feynman had only calculated the difference between the neutron and the proton form factor, while Slotnick had obtained the separate form factors, it was clear that with another few hours' work Feynman could easily get the separate pieces.

Feynman (1980b) excitedly asserts,

This is when I really knew I had something. I didn't really know that I had something so wonderful as when this happened . . . . That was the moment that I really knew that I had to publish—that I had gotten ahead of the world . . . . That was the fire.

That was the moment when I got my Nobel Prize, when Slotnick told me that he had been working two years. When I got the real prize it was really nothing, because I already knew I was a success. That was an exciting moment<sup>41</sup> (Feynman, 1980b).

<sup>41</sup>Feynman (1985b) points out that what he meant by "That was the moment I got my Nobel Prize" was not that was when he knew that he would win a Nobel Prize, ". . . which never entered my head. What I mean was that was the moment I got a "prize" of thrill and delight in discovery. I had something wonderful and useful." In his Nobel acceptance speech, Feynman put it thus:

That was a thrilling moment for me, like receiving the Nobel Prize, because it convinced me, at last, I did have some kind of method and technique and understood how to do something that other people did not know how to do. That was my moment of triumph in which I realized I really had succeeded in working out something worthwhile" (Feynman, 1966a, p. 707).

After Case gave his paper, Feynman got up and commented, "But what about Slotnick's calculation? Your theorem must be wrong because a simple calculation shows that it's correct. I checked Slotnick's calculation and I agree with it"<sup>42</sup> (Feynman, 1980b).

He was of course turning the tables on Oppenheimer for his arrogant dismissal of Slotnick's calculations.

"I had fun with that," Feynman admits (Feynman, 1980b).

Case sent him a preprint of his paper, and Feynman felt obliged to find out "what is the matter with the damned thing" (Feynman, 1980b). Since it was written in the usual field-theoretic language using second-quantized field operators, Feynman had difficulty reading it. Up to that time he had not studied second quantization. Feynman (1966a), remembers that on a previous occasion

when someone had started to teach me about creation and annihilation operators, that this operator creates an electron, I said "how do you create an electron? It disagrees with the conservation of charge," and in this way I blocked my mind from learning a very practical scheme of calculation (Feynman, 1966a, p. 706).

But this time he got Scalletar, then a graduate student at Cornell, to explain to him this formalism and proceeded to find the mistake that Case had made.<sup>43</sup>

Learning to express hole theory in the second-quantized formalism turned out to be useful. It allowed Feynman to deal with vacuum processes in a way that had not been possible before. The appendixes in Feynman's "The Theory of Positrons" (Feynman, 1949b), in which the equivalence of his approach with the second-quantized version of positron theory is demonstrated (Appendix A) and the rules for handling vacuum processes are justified (Appendix B), are some of the fruits of this labor.

The other dividend from the Slotnick episode was that Feynman learned the different kinds of meson theories and formulated the rules for calculating with them. In less than two months, during the spring of 1949, he recalculated to order  $g^2$  all the meson-theoretic calculations that had ever been performed up to that time—and many more. These efforts were summarized in the concluding

<sup>42</sup>F. Low (private communication) points out that it is interesting that Feynman got the same answer as Slotnick, since a controversy arose over the calculation of the electron-neutron interaction. There were two calculations using standard perturbation theory, one by Slotnick and Heitler (1949) and the other by Dancoff and Drell (1949), which agreed with one another. There were two others using the Schwinger formalism, one by Case (1949a) and the other by Borowitz and Kohn (1949), which agreed with each other but not with the calculations of Slotnick and Drell. The situation was resolved by Foldy (1952), who found Slotnick and Drell to be right.

<sup>43</sup>The paper that Case submitted to the *Physical Review* contains an acknowledgment stating "Thanks are due to Dr. R. P. Feynman for pointing out an error in the original manuscript" (Case, 1949b).

paragraph of his "Space-Time Approach to Quantum Electrodynamics:"

Calculations are very easily carried out in this way to lowest order in  $g^2$  for the various theories for nucleon interaction, scattering of mesons by nucleons, meson production by nuclear collisions and by gamma rays, nuclear magnetic moments, neutron-electron scatterings, etc. However, no good agreement with experiment[all] results, when these are available, is obtained. Probably all of the formulations are incorrect. An uncertainty arises since the calculations are only to first order in  $g^2$ , and are not valid if  $g^2/\hbar c$  is large (Feynman, 1949c, p. 784).

By the spring of 1949 everything was in place. Simple rules for obtaining the contributions from the various orders of perturbation theory could be stated in terms of their associated Feynman diagrams, efficient calculational methods had been developed, gauge-invariant cutoff methods were available for rendering finite the vacuum polarization, self-energy, and vacuum diagrams. Feynman could have proceeded by first publishing the equivalence of his approach with conventional quantum field theory. But Rabi at the Pocono conference had urged him to publish his rules and computational methods as soon as possible. Feynman followed Rabi's advice. Also, Feynman's proof of the equivalence was predicated on his operator calculus, which would have given his presentation a mathematical and formal aspect he wanted to eschew. Finally the order of appearance of the various papers—first the simple rules and efficient calculational methods, then the formal aspects—also reflected a latent hope, that he might yet be able to make quantum electrodynamics finite.

#### D. Retrospective

Commenting on what he had accomplished in the period from 1947 to the writing of his two classic papers in 1949, Feynman (1980b) expresses some disappointment. He had come to quantum electrodynamics "from the desire to fix this problem," but he "didn't fix it." He had invented a more efficient way of calculating, but it was not "fixing it."

I invented a better way to figure, but I hadn't fixed what I had wanted to fix . . . . I had kept the relativistic invariance under control and everything was nice . . . , but I hadn't fixed anything . . . . The problem was still how to make the theory finite . . . . I wasn't satisfied at all (Feynman, 1980b).

Feynman (1965) expressed these same feelings to the student newspaper that interviewed him on the day of the announcement that he had received the Nobel Prize:

It was for the purpose of making these simplified methods of calculating more available that I published

my paper in 1949, for I still didn't think I had solved any real problems, except to make more efficient calculations. But it turns out that if the efficiency is increased enough, it itself is practically a discovery. It was a lot faster way of doing the old thing (Feynman, 1965).

Feynman has the distinct recollection that he felt then that he was doing something "sort of temporarily" while exploring the consequences of a patched-up retarded formulation of quantum electrodynamics, and that his real love lay in the  $\frac{1}{2}$  (advanced and retarded) formulation—

I was still expecting that I would some day come through the other end of my original idea . . . and get finite answers, get that self-radiation out and the vacuum circles and that stuff straightened out . . . which I never did (Feynman, 1980b).

There is in fact a paragraph in his "Space-Time Approach to Quantum Electrodynamics" in which Feynman apologizes for publishing his theory prematurely because he could not make it finite:

One can say . . . that this attempt to find a consistent modification of quantum electrodynamics is incomplete . . . . The desire to make the methods of simplifying the calculation of quantum electrodynamics processes more widely available has prompted this publication before an analysis of the correct form for  $f_+$  is complete. One might try to take the position that, since the . . . discrepancies discussed vanish on the limit [that the cutoff]  $\lambda \rightarrow \infty$ , the correct physics might be considered to be that obtained by letting  $\lambda \rightarrow \infty$  after mass renormalization. I have no proof of the mathematical consistency of this procedure but the presumption is very strong that it is satisfactory" (Feynman, 1949c, p. 778).

Feynman added the further statement that the presumption that a satisfactory form for  $f_+$  could be found "is [also] very strong."

In retrospect, Feynman (1980b) considers this paragraph "the one big mistake in the paper."

Feynman's hopes of being able to find a finite, consistent formulation of QED polarized his view of renormalization theory. He believes that he understood renormalizing "crudely":

All I knew was that I had done a few problems, that I had noticed the obvious. As soon as the diagrams get more complicated the number of denominators increases and everything is OK . . . . That the only things that gave you trouble were these things [the self-energy diagrams], I knew that. I knew that idea that was suggested by Weisskopf and Bethe, to me by Bethe, that [if] you correct the mass everything would be all right, that [if] you correct the charge everything will be all right . . . that it was right, because these two diagrams are the only ones that make any difference. But I never proved it. If Dyson were to have come to me and told me that there is some difficulty with bubble diagrams or something, I would have been a little nervous because maybe there is some trouble with bubble diagrams.

In my world of physics, things were known better or worse, more sure or less sure. I knew a lot more than I

could prove . . . as being extremely likely.<sup>44</sup> So I would look at something like this [renormalization] and I considered I knew everything was all right. I didn't know it in the sense that I could prove it to anybody fully, carefully; but I knew . . . because I had done enough things that everything was OK. But if he Dyson would have come along with a diagram I didn't do, and discovered that there was something wrong there, I would say that there was a certain probability that he was right. He didn't actually! That's the kind of way I knew it. The odds were on it, the odds were for it. I realized how it worked and how it probably worked but I didn't really check it out (Feynman, 1980b).

Feynman's views on renormalization were stated publicly in an invited paper he delivered in June of 1949 at the

<sup>44</sup>Among Feynman's papers is an undated two-page manuscript on Fermat's theorem (that  $x^n + y^n = z^n$  is impossible for positive integer values of  $x, y, z, n$  if  $n > 2$ ), which illustrates the meaning of "more sure, less sure" in Feynman's world. He first asks, "What is the prob[ability]  $N$  is a perfect  $n$ th power?" To answer the question he observes that the spacing between  $N^{1/n}$  and  $(N+1)^{1/n}$  is  $(1/n)N^{1/n-1}$  (for large  $N$ ). Therefore "Probability that  $N$  is perfect  $n$ th power is  $(N^{1/n})/nN$  [and] therefore probability that  $x^n + y^n$  is perfect  $n$ th power is  $(x^n + y^n)^{1/n}/n(x^n + y^n)$ . Therefore total probability any  $x^n + y^n$  is perfect  $n$ th power for  $x > x_0$  and  $y > y_0$  is equal to

$$\int_{x_0}^{\infty} \int_{y_0}^{\infty} \frac{1}{n} (x^n + y^n)^{-1+1/n} dx dy = \frac{2}{nx_0^{n-3}} c_n$$

where

$$c_n = \frac{1}{2} \int_0^{\infty} \int_0^{\infty} (u^n + v^n)^{-1+1/n} du dv .$$

Feynman notes if  $n=2$  the integral diverges badly—"i.e., [we] expect infinite no. of coincidences." For  $n=3$  the result is independent of  $x_0$ , but  $c_3$  diverges logarithmically "so we cannot tell about  $n=3$  by chance. Must do theorem analytically.  $\therefore$  Restrict  $n \geq 4$ ." For large  $n$ ,  $c_n$  is roughly  $\approx 1/2n$ , therefore

$$\text{"probability success for } n, x_0 = \frac{1}{n^2 [x_0(n)]^{n-3}}$$

[and] probability success any

$$n > n_0 = \int_{n_0}^{\infty} \frac{d\mu}{\mu^2 [x_0(\mu)]^{\mu-3}} = \pi_{n_0}$$

Feynman then asks what is the smallest  $x_0$  for which theorem "has any chance at all." From the knowledge that the theorem is true for  $n \leq 100$ , and an estimate for  $\pi_{n_0}$  for  $n_0 > 100$ , he deduces that "probability (success) is certainly less than  $10^{-200}$ ," and so concludes

"For my money Fermat's theorem is true."

It would of course be very satisfying to have an elegant proof of the theorem, but as far as he is concerned he "knows" it is right even though he cannot prove it rigorously. The power of the method was, however, found to be limited. Professor Morgan Ward indicated to him "that the same argument would show that an equation like  $x^7 + y^{13} = z^{11}$  (powers prime to each other) would be unlikely to have integer solutions—but that they do, an infinite number of them!" (Feynman, 1985b).

APS meeting at the University of Washington in Seattle:

The philosophy behind these ideas [renormalization] might be something like this:

A future electrodynamics may show that at very high energy our theory is wrong. In fact we might expect it to be wrong because undoubtedly high-energy gamma rays may be able to produce mesons in pairs, etc., phenomena with which we do not deal in the present formulation of the electron-positron electrodynamics. If the electrodynamics is altered at very short distances then the problem is how accurately can we compute things at relatively long distances. The result would seem to be this: the only thing which might depend sensitively on the modification at short distances is the mass and the charge. But . . . all observable processes will be relatively insensitive and we are now in a position to be able to compute these real processes fairly accurately without worrying about the modifications at high frequencies. Of course it is an experimental problem yet to determine to what extent the calculations we are now able to make are in agreement with experience.

In other words, it seems as though with these methods of mass and charge renormalization we have a consistent and definite electrodynamics for the calculation of all possible processes involving photons, electrons, and positrons.

I do not expect that this electrodynamics is correct at all energies, but in some sense it is modified at high energies. Of course, I do not expect that the particular modification I have chosen is correct. (It is, furthermore, completely unsatisfactory, being at variance with energy conservation.)

The statement that electrodynamics is now definite, consistent, and free of divergences is my opinion. Although various partial proofs or convincing arguments may be and have been brought to bear on the subject, the actual situation is very poor from the point of view of mathematical rigor. I shall try to describe the situation in its most favorable light although my personal opinion is that in electrodynamics of electrons everything is all right (Feynman, 1949g).

Feynman did not study Dyson's two papers on renormalization (Dyson, 1949a, 1949b). He accepted Dyson's statement that he knew what was in them. In any case, Feynman never felt order-by-order was anything but an approximation to the "thing" and the "thing" was the path integral. He "could write the expression which is supposed to be correct to arbitrary coupling and the expansion was only a demonstration of a practical calculation" (Feynman, 1980b).

However,

the rules I made [for the diagrams] were simpler than the way I got them. These rules were in fact equivalent to the field theory. A way of saying what quantum electrodynamics was, was to say what the rule was for the arbitrary diagram—although I really thought behind it was my action form (Feynman, 1980b).

Incidentally, these rules reflected an amalgamation of what Wheeler and Bethe had taught Feynman. The Feynman rules followed the plan Wheeler had given for carrying out calculations using the solutions of the  $\frac{1}{2}$  (ad-

vanced + retarded) formulation of classical electrodynamics in their absorber theory (Wheeler and Feynman, 1945; Galison, 1982). But the calculations in that case were aimed at checking the theory's consistency and comparing its results with the conventional formulation using retarded potentials. The influence of Bethe is apparent in that the Feynman rules were designed to calculate observable phenomena and to "get numbers out" as efficiently as possible.

The 1949 papers contained the rules for the diagrams. The justification (and validity) of the rules appeared in two papers Feynman published in 1950 and 1951. These papers contain much of what Feynman had done in 1947 and 1948—for example, the derivation of the action when both the longitudinal and the transverse radiation oscillators were integrated out—but now the results were *derived* in a rigorous fashion. Whereas previously, to handle Dirac particles, Feynman would replace the velocity  $v$  by  $\alpha$  in the action, he could now justify these steps by using his calculus of ordered operators: "I knew the facts all the time, but I didn't know how I knew it" (Feynman, 1980b). Now he proved all the rules that had seemed intuitively right or had been established by trial and error and checked with answers obtained by the more conventional approaches. The appendixes to these papers contain a wealth of deep insights. Feynman characterizes them as "all my equipment being distributed—all the things I discovered on the way" (Feynman, 1980b).

The central result of Feynman's 1950 paper is a functional differential equation for the transition amplitude for a system of charges, each carrying the same charge  $e$ , and each interacting with the quantized electromagnetic field. In addition, each charge is assumed subject to an external (classically prescribed) electromagnetic field generated by a 4-vector potential  $B_\mu$ , a function of space and time. Feynman made the assumption that the charge  $e$  and the potentials  $B_\mu$  could be independently varied. If  $T = T_{e^2}[B]$  is the probability amplitude for finding the system in a given final state at time  $t''$ , given the initial state of some earlier  $t'$ , then Feynman showed that  $T$  satisfies the functional differential equation

$$\frac{dT_{e^2}[B]}{de^2} = \frac{1}{2}i \int_{t'}^{t''} \int_{t'}^{t''} \frac{\delta^2 T_{e^2}[B]}{\delta B_\mu(1)\delta B_\mu(2)} \times \delta_+(s_{12}^2) d\tau_1 d\tau_2, \quad (7.6)$$

where the integration is over the two space-time points  $x_1, x_2$  and  $s_{12}^2 = (x_1 - x_2)_\mu (x_1 - x_2)_\mu$ . The amplitude  $T_0[B]$  describes the behavior of noninteracting particles in the external field  $B_\mu$ , and can be computed exactly (in principle) in all cases of interest. The differential equation (7.6) determines  $T_{e^2}[B]$  uniquely, given the boundary value at  $e^2 = 0$ . Feynman then verified that when the equation is solved by a series expansion, the result is the calculational rules given in "Space-Time Approach to Quantum Electrodynamics" (Feynman, 1949c). In the final section of the paper, Feynman deduced additional

rules that extended the results to processes in which real photons are present in the initial and final states.

In Appendix A of the paper, Feynman gave a formally covariant treatment of particles satisfying the Klein-Gordon equation, making use of proper time as an independent variable. In Appendix B he discussed, in a general way, relations between real and virtual processes involving photons. In Appendix C he derived a wave equation for  $\Phi_{e^2}[B, x]$ , the probability amplitude for finding at  $x_\mu$  a Dirac electron interacting with the quantized electromagnetic field and with an external field  $B_\mu$ ,

$$(i\nabla - m)\Phi_{e^2}[B, x] = B(x)\Phi_{e^2}[B, x] + ie^2 \int \delta_+(s_{x1}^2) \frac{\delta \Phi_{e^2}[B, x]}{\delta B_\mu(1)} d\tau_1. \quad (7.7)$$

This "equation contains in compact form the modification introduced into the Dirac theory of the electron by the interaction of the electron with its own field" (Dyson, 1951). It also encapsulates the advances made in the twenty-year period from the time Dirac advanced his equation for a spin- $\frac{1}{2}$  particle to the post-World-War-II developments in QED. Feynman's final paper in the series, "An operator calculus having applications to quantum electrodynamics" (Feynman, 1951a), was the capstone of what he had accomplished in the period 1947–1949.

A letter Feynman wrote to Wheeler in the spring of 1951 conveys the feeling that a chapter in Feynman's intellectual life had been closed with the writing of these papers:

I wanted to know what your opinion was about our old theory of action at a distance. It was based on two assumptions:

- (1) Electrons act only on other electrons
- (2) They do so with the mean of retarded and advanced potentials

The second proposition may be correct but I wish to deny the correctness of the first. The evidence is twofold. First there is the Lamb shift in hydrogen which is supposedly due to the self-action of the electron. It is true that we do not have a complete quantum theory of proposition one, so that we cannot be certain that the Lamb shift would not come from the net action on the hydrogen atom of the atoms in the surrounding walls. That is why I am asking for your opinion. Do you believe that this reaction part of the energy could really be accounted for in this way?

The second argument involves the idea that positrons are electrons going backwards in time. If this were the case, an electron and positron which were destined to annihilate one another would not interact according to proposition one, since they are actually the same charge. Thus, positronium could not be formed and subsequently decay, for if it were to decay it would mean that the electron and positron were the same particle and therefore should not have been exerting a force on one another. But they were exerting a Coulomb interaction in order to form the bound positronium state . . . .

Finally Deutsch has . . . experimental evidence that positronium is formed in a stable state and subsequently decays.

So I think we guessed wrong in 1941. Do you agree? (Feynman, 1951b).

Feynman himself states "QED was over when I did the papers" (Feynman, 1980b). These papers, on the space-time approach to nonrelativistic quantum mechanics (Feynman, 1948a, 1948b, 1948c), on quantum electrodynamics (1949b, 1949c, 1950a), and on his operator calculus (Feynman, 1951a), must surely be placed near the top of any list of the most seminal and influential papers in theoretical physics during the twentieth century.

### VIII. EPILOGUE: STYLE AND VISUALIZATION

In a talk he gave to the Caltech YMCA on "The Relation of Science and Religion," Feynman (1956) characterized science as follows:

. . . science can be defined as a method for, and a body of information obtained by, trying to answer only questions which can be put into the form: If I do this, what will happen? The technique, fundamentally, is: Try it and see. Then you put together a large amount of information from such experiences. All scientists will agree that a question—any question, philosophical or other—which cannot be put into the form that can be tested by experiment (or, in simple terms, that cannot be put into the form: If I do this, what will happen?) is not a scientific question; it is outside the realm of science.

Feynman went on and stressed that

. . . it is imperative in science to doubt; it is absolutely necessary, for progress in science, to have uncertainty as a fundamental part of your inner nature. To make progress in understanding we must remain modest and allow that we do not know. Nothing is certain or proved beyond all doubt. You investigate for curiosity, because it is *unknown*, not because you know the answer. And as you develop more information in the sciences, it is not that you are finding out the truth, but that you are finding out that this or that is more or less likely.

That is, if we investigate further, we find that the statements of science are not of what is true and what is not true, but statements of what is known to different degrees of certainty . . . . Every one of the concepts of science is on a scale graduated somewhere between, but at neither end of, absolute falsity or absolute truth (Feynman, 1956, p. 21).

Moreover, Feynman indicated that it was necessary to accept this idea of uncertainty "not only for science, but also for other things." This notion of the uncertainty of our knowledge is central to Feynman's approach in his attempts to understand the physical world. Recall his statement "In my world of physics, things [are] known better or worse, more sure or less sure."

The maxim "the main job of theoretical physics is to prove yourself wrong as soon as possible" characterizes

the way Feynman works. He attributes the saying to "his friend Welton" (Feynman, 1947e, 1954a). Very early on Feynman searched for ways to implement this strategy. In a letter to his friend H. C. Corben written in the fall of 1947, Feynman elaborated on this approach to theoretical physics. Corben had asked him to comment on some work he had done on a relativistic theory of classical spinning particles and Feynman (1947e) replied

. . . I think the quickest way to find out whether there is anything really in your stuff would be this: Take some specific problem or problems, e.g., a single particle in an external field, if that means anything—or two interacting particles. Try to work the thing, if necessary, in one dimension (I mean four: space, time, momentum, and energy). I have always found that it is when I try to do simple problems, that I find the main problems. This way you will find out just what the quantities mean or can mean.

Feynman's genius combines great analytic skills, keen powers of visualization, impressive physical intuition, with almost unbounded physical energy and the ability to concentrate intensely on the demands of any task. He has a deep need to understand things his own way and to work out problems his own way. This passion, combined with his immense powers, makes it easier for him to derive the results of a paper on his own than to read it:

I have a lot of trouble reading papers. I have a lot of trouble understanding them. I don't have trouble working them out for myself . . . . It is easier working it out for myself than reading it; except a new idea somebody will *tell* me and I'll go home with the clever idea . . . and work out what he is trying to tell, and understand what he is trying to tell me; but if he writes the paper I have trouble understanding . . . (Feynman, 1980b).

In a revealing account of how his mind works Feynman stated:

I cannot explain what goes on in my mind clearly because I am actively confusing it and I cannot introspect and know what's happening. But visualization in some form or other is a vital part of my thinking and it isn't necessary I make a diagram like that. The diagram is really, in a certain sense, the picture that comes from trying to clarify visualization, which is a half-assed kind of vague, mixed with symbols. It is very difficult to explain, because it is not clear. My atom, for example, when I think of an electron spin in an atom, I see an atom and I see a vector and a  $\psi$  written somewhere, sort of, or mixed with it somehow, and an amplitude all mixed up with  $x$ s. It is impossible to differentiate the symbols from the thing; but it is very visual. It is hard to believe it, but I see these things not as mathematical expressions but a mixture of a mathematical expression wrapped into and around, in a vague way, around the object. So I see all the time visual things associated with what I am trying to do.

It was always with visualization. There was a lot of visualization and a lot of analysis. Analysis is much more powerful when you can do it, especially when you



want to publish something or explain something; or when you want to be sure that what you have thought is clear and correct. Then the analysis, the mathematics is wonderful. That's why it looks like, when I write it, trying to do mathematics.

What I really am trying to do is to bring birth and clarity, which is really a half-assedly thought out pictorial semi-vision thing. OK?

I would see this jiggle-jiggle-jiggle, or the wiggle of the path or the influence of the other thing. Even when I talk now about the influence functional: I see the coupling and I try, I take this turn—like as if there is a big bag of stuff and try to collect it away and to push it. It's all visual . . .

I see the character of the answer before me—that's what the picturing is.

Ordinarily I try to get the pictures clearer, but in the end, the mathematics can take over and can be more efficient in communicating the idea than the picture (Feynman, 1980b).

When one listens to Feynman explain anything, it becomes evident that not only the "visual" but also the "acoustical" plays an important role in "giving birth and clarity." The sounds—the jiggle-jiggle-jiggle, the swishing or fading sounds denoting exponential growth or decay—the modulation of his voice, the rapidity of his speech—the "verbal" trying to keep pace with the "mental"—all make clear that oral communication is more than translating the "visual" into sound. Verbal interaction—to explain, to clarify, to obtain information or criticism—is for Feynman the most efficient way to communicate.

What is immediately clear in any form of communication with him is that one is in contact with a remarkable human being.

#### ACKNOWLEDGMENTS

I would like to thank R. P. Feynman for permission to study the papers that he has deposited in the Archives of the Millikan Library, California Institute of Technology, and for commenting on the manuscript of the present paper. I am also indebted to him and C. Weiner for making available the transcript of their remarkable interview (Feynman, 1966b). I have received valuable suggestions, insights, recollections, and manuscript materials from H. A. Bethe, F. J. Dyson, R. P. Feynman, P. Morrison, J. Schwinger, V. Weisskopf, T. A. Welton, J. A. Wheeler, A. S. Wightman, and E. P. Wigner. I am grateful to them. L. Abbott, J. Feynman, R. Jost, E. Keller, M. Krieger, F. Low, and H. Pendleton made helpful comments on a draft of the present paper. I thank them. I would also like to acknowledge the help received from J. Goodstein, the archivist at Caltech, and from the archivists at the libraries of the American Institute of Physics, Cornell University, and Massachusetts Institute of Technology. My research was supported in part by a grant from the National Science Foundation during 1980–1981.

#### REFERENCES

- Badash, L., J. O. Hirschfelder, and H. P. Broida, Eds., 1980, *Reminiscences of Los Alamos, 1943–1945* (Reidel, Dordrecht).
- Baranger, M., H. A. Bethe, and R. P. Feynman, 1953, *Phys. Rev.* **92**, 482.
- Bernstein, J., 1979, *New Yorker*, October, 47 and November, 47.
- Bethe, H. A., 1937, *Rev. Mod. Phys.* **9**, 69.
- Bethe, H. A., 1945, letter to R. C. Gibbs, 25 July. RPF, CIT 1.33.\*
- Bethe, H. A., 1947, *Phys. Rev.* **72**, 339. Reprinted in Schwinger (1958).
- Birge, R. T., 1945, letter to R. P. Feynman, 5 July. RPF, CIT 1.9.\*
- Bloch, F., and A. Nordsieck, 1937, *Phys. Rev.* **52**, 54.
- Blumberg, S. A., and G. Owens, 1976, *The Life and Times of Edward Teller* (Putnam's, New York).
- Bohr, A., 1980, letter to S. S. Schweber, 18 August.
- Borowitz, S., and W. Kohn, 1949, *Phys. Rev.* **76**, 818.
- Case, K. M., 1949a, *Phys. Rev.* **75**, 1306.
- Case, K. M., 1949b, *Phys. Rev.* **76**, 1.
- Case, K. M., 1949c, *Phys. Rev.* **76**, 14.
- Clogston, A. M., 1984, letter to S. S. Schweber, 3 October.
- Corben, B., 1984, letter to S. S. Schweber, 11 September.
- Corben, M., 1947, letter to R. P. Feynman, 24 November. RPF, CIT 1.23.\*
- Dancoff, S., 1939, *Phys. Rev.* **55**, 959.
- Dancoff, S., and S. Drell, 1949, *Phys. Rev.* **76**, 205.
- Darrow, K. K., 1948, postcard to D. MacInnes, 16 January, MacInnes Papers, Rockefeller University Archives.
- de Broglie, M., 1951, *Les Premiers Congrès de Physique Solvay et l'Orientation de la Physique depuis 1911* (Editions Albin Michel, Paris).
- de Broglie, M., and P. Langevin, 1912, *La Théorie du Rayonnement et les Quanta, Rapports et Discussions de la Réunion venue à Bruxelles du 30 Octobre au 3 Novembre 1911. Sous les auspices de M. E. Solvay* (Gauthier-Villars, Paris).
- Deutsch, M. E., 1945, letter to R. P. Feynman 3 July. RPF, CIT 1.33.\*
- Deutsch, M., 1951, *Phys. Rev.* **82**, 455(L).
- Deutsch, M., and M. Dulit, 1951, *Phys. Rev.* **84**, 601(L).
- Dirac, P. A. M., 1927, *Proc. R. Soc. London Ser. A* **114**, 243. Reprinted in Schwinger (1958).
- Dirac, P. A. M., 1930, *Proc. R. Soc. London Ser. A* **126**, 260.
- Dirac, P. A. M., 1932, *Phys. Z. Sowjetunion* **3**, 64. Reprinted in Schwinger (1958).
- Dirac, P. A. M., 1933, in *Septième Conseil de Physique Solvay* (Gauthier-Villars, Paris). Reprinted in Schwinger (1958).
- Dirac, P. A. M., 1935, *The Principles of Quantum Mechanics*, 2nd ed. (Clarendon, Oxford).
- Dirac, P. A. M., 1938, *Proc. R. Soc. London Ser. A* **167**, 148.
- Dirac, P. A. M., 1946, letter to R. P. Feynman, 23 July, Mudd Archives, Princeton University Bicentennial Papers.
- Dyson, F. J., 1948, letter to his parents, 1 November. The letter is in F. J. Dyson's possession.

\*All materials referred to as RPF, CIT are located among the papers that R. P. Feynman has deposited in the Archives of the Millikan Library, California Institute of Technology. 2.5 means box 2, folder 5.

- Dyson, F. J., 1949a, Phys. Rev. 75, 486. Reprinted in Schwinger (1958).
- Dyson, F. J., 1949b, Phys. Rev. 75, 1736. Reprinted in Schwinger (1958).
- Dyson, F. J., 1951, Math. Rev. 12, 889.
- Dyson, F. J., 1979, *Disturbing the Universe* (Harper and Row, New York).
- Eisenbud, L., 1984, telephone interview with S. S. Schweber, December 8.
- Eyges, L., 1984, letter to S. S. Schweber, 14 September.
- Fermi, E., 1932, Rev. Mod. Phys. 4, 87. Reprinted in Schwinger (1958).
- Feynman, J., 1984, interview with S. S. Schweber, 18 December.
- Feynman, J., 1985, written communication to S. S. Schweber, January.
- Feynman, R. P., 1933–1934, notebooks. Richard Feynman Papers, Niels Bohr Library, AIP, N.Y.
- Feynman, R. P., 1939a, "Forces and Molecules," senior thesis (Massachusetts Institute of Technology), Archives, MIT.
- Feynman, R. P., 1939b, Phys. Rev. 56, 340.
- Feynman, R. P., 1940, "Things I don't know," notebook. RPF, CIT 15.1.\*
- Feynman, R. P., 1941, "The Interaction Theory of Radiation." RPF, CIT 6.1.\*
- Feynman, R. P., 1942, "The Principle of Least Action in Quantum Mechanics," Ph.D. thesis (Princeton University).
- Feynman, R. P., 1945a, letter to M. E. Deutsch, 27 July. RPF, CIT 1.33.\*
- Feynman, R. P., 1945b, letter to M. E. Deutsch, 8 August. RPF, CIT 1.33.\*
- Feynman, R. P., 1946a, note to himself. RPF, CIT 13.3.\*
- Feynman, R. P., 1946b, notes labeled "Assay," 25 February. RPF, CIT 13.3.\*
- Feynman, R. P., 1946c, radio talk, "The Scientists Speak," 17 April, Bethe Papers, Cornell University Archives.
- Feynman, R. P., 1946d, "Notes on Dirac Equation." RPF, CIT 13.3.\*
- Feynman, R. P., 1947a, letter to T. A. Welton, 10 February. RPF, CIT 3.9.
- Feynman, R. P., 1947b, notes entitled "Brief description of Wheeler-Feynman Electrodynamics," summer, 1947. RPF, CIT 12.9.\*
- Feynman, R. P., 1947c, notes entitled "Elimination of field oscillators," summer, 1947. RPF, CIT 12.9.\*
- Feynman, R. P., 1947d, notes entitled "Self-interactions of 2 particles," summer, 1947. RPF, CIT 12.9.\*
- Feynman, R. P., 1947e, letter to Bert and Mulaika Corbin [sic; Corben], 6 November. RPF, CIT 1.23.\*
- Feynman, R. P., 1947f, letter to Mr. and Mrs. Corbin [sic; Corben], 19 November. RPF, CIT 1.23.\*
- Feynman, R. P., 1947g, handwritten notes entitled "Theory of Positrons," fall, 1947. RPF, CIT 13.1.\*
- Feynman, R. P., 1947h, "Notes on Dirac Equation," RPF, CIT 13.3.\*
- Feynman, R. P., 1948a, Phys. Rev. 74, 939.
- Feynman, R. P., 1948b, Phys. Rev. 74, 1430.
- Feynman, R. P., 1948c, Rev. Mod. Phys. 20, 367. Reprinted in Schwinger (1958).
- Feynman, R. P., 1948d, letter to Prof. and Mrs. H. M. Corben, 15 January. RPF, CIT 1.23.\*
- Feynman, R. P., 1948e, letter to Prof. and Mrs. H. M. Corben, 20 March. RPF, CIT 1.23.\*
- Feynman, R. P., 1948f, "Alternative for Formulation of Quantum Electrodynamics," in Wheeler (1948).
- Feynman, R. P., 1948g, letter to H. A. Bethe, 7 July, Bethe Papers, Cornell University Archives.
- Feynman, R. P., 1948h, letter to H. A. Bethe, 22 July, Bethe Papers, Cornell University Archives.
- Feynman, R. P., 1948i, letter to F. J. Dyson, 29 October. RPF, CIT 1.30.\*
- Feynman, R. P., 1948j, letter to T. Welton, 30 October. RPF, CIT 3.9.\*
- Feynman, R. P., 1948k, "T5. Theory of Positrons," unpublished manuscript, December, 1948(?). RPF, CIT 6.13.\*
- Feynman, R. P., 1949a, Phys. Rev. 75, 1321.
- Feynman, R. P., 1949b, Phys. Rev. 76, 749. Reprinted in Schwinger (1958).
- Feynman, R. P., 1949c, Phys. Rev. 76, 769. Reprinted in Schwinger (1958).
- Feynman, R. P., 1949d, letter to C. Kelber, 21 February. RPF, CIT 2.12.\*
- Feynman, R. P., 1949e, letter to J. A. Wheeler, 10 November. RPF, CIT 3.10.\*
- Feynman, R. P., 1949f, letter to J. A. Wheeler, 8 December. RPF, CIT 3.10.\*
- Feynman, R. P., 1949g, Phys. Rev. 76, 584. Manuscript is in RPF, CIT 13.1.\*
- Feynman, R. P., 1950a, Phys. Rev. 80, 440.
- Feynman, R. P., 1950b, letter to C. Morette, 5 June. RPF, CIT 2.26.\*
- Feynman, R. P., 1951a, Phys. Rev. 81, 108.
- Feynman, R. P., 1951b, letter to J. A. Wheeler, May 4. RPF, CIT 3.10.\*
- Feynman, R. P., 1954a, Ann. Acad. Bras. Cienc. 26, 51.
- Feynman, R. P., 1954b, lecture entitled "Inertia." RPF, CIT 2.5.\*
- Feynman, R. P., 1956, Eng. Sci., June, 20.
- Feynman, R. P., 1965, in *California Tech* (Caltech newspaper) LXVII, No. 5 1/2, 22 October.
- Feynman, R. P., 1966a, Science 153, 699.
- Feynman, R. P., 1966b, interview with C. Weiner, March, Center for History and Philosophy of Physics, AIP, N.Y.
- Feynman, R. P., 1976, Eng. Sci. 39, 11.
- Feynman, R. P., 1978, remarks at banquet honoring J. Schwinger on the occasion of his 60th birthday, February, Center for History and Philosophy of Physics, AIP, N.Y.
- Feynman, R. P., 1980a, in *Reminiscences of Los Alamos, 1943–1945*, edited by L. Badash, J. O. Hirschfelder, and H. P. Broida (Reidel, Dordrecht), p. 105.
- Feynman, R. P., 1980b, taped interview with S. S. Schweber, Nov. 13.
- Feynman, R. P., 1985a, letter to S. S. Schweber, 28 January.
- Feynman, R. P., 1985b, "Surely You're Joking Mr. Feynman!" *Adventures of a Curious Character* (Norton, New York).
- Feynman, R. P., R. B. Leighton, and M. Sands, 1964, *The Feynman Lectures on Physics* (Addison-Wesley, Reading, Mass.), Vol. II.
- Feynman, R. P., and T. A. Welton, 1936–1937, notebook. Richard Feynman Papers, Niels Bohr Library, AIP, N.Y.
- Fokker, A. D., 1929, Z. Phys. 58, 386.
- Fokker, A. D., 1932a, Physica 9, 33.
- Fokker, A. D., 1932b, Physica 9, 145.
- Foldy, L. L., 1952, Phys. Rev. 87, 693.
- Frenkel, J., 1925, Z. Phys. 32, 518.
- Furry, W. H., 1934, letter to V. F. Weisskopf, 21 June, Weisskopf papers, The Archives, MIT library.
- Furry, W. H., 1979, interview with J. Ovggaard and S. S. Schweber, 17 June.

- Galison, P., 1982, Comments on a paper by S. S. Schweber for the Boston Colloquium for the History and Philosophy of Science.
- Gibbs, R. C. 1945a, letter to C. de Kiewiet, 31 July. RPF, CIT 1.33.\*
- Gibbs, R. C., 1945b, letter to R. P. Feynman, 3 August. RPF, CIT 1.33.\*
- Gold, T., 1965, letter to R. P. Feynman, October. RPF, CIT 5.8.\*
- Gold, T., and D. L. Schumacher, 1967, Eds., *The Nature of Time* (Cornell University, Ithaca).
- Groueff, S., 1967, *Manhattan Project: The Untold Story of the Making of the Atomic Bomb* (Little, Brown, Boston).
- Hawkins, D., 1983, *Manhattan District history, Project Y: The Los Alamos Story Part I. Toward Trinity* (Tomash, Los Angeles).
- Heisenberg, W., and W. Pauli, 1929, Phys. 56, 1.
- Heisenberg, W., and W. Pauli, 1930, Phys. 59, 168.
- Heitler, W., 1936, *The Quantum Theory of Radiation* (Clarendon, Oxford).
- Herring, C., 1984, letter to S. S. Schweber, 18 December.
- Hewlett, R. G., and O. E. Anderson, 1962, *The New World, 1939/1946. A History of the United States Atomic Energy Commission* (Pennsylvania State University, State Park, PA), Vol. I.
- Jehle, H., 1980, letter to S. S. Schweber, 10 September.
- Kramers, H. A., 1938, *Nuovo Cimento* 15, 108. Reprinted in Kramers (1956).
- Kramers, H. A., 1944, *Ned. Tijdschr. Natuurk.* 11, 134. Reprinted in Kramers (1956).
- Kramers, H. A., 1947, quoted in Schweber (1985), p. 339.
- Kramers, H. A., 1956, *Collected Scientific Papers* North-Holland, Amsterdam).
- Lamb, W. E., and R. C. Retherford, 1947, Phys. Rev. 72, 241.
- Lewis, H., 1948, Phys. Rev. 73, 173.
- Livingston, M. S., and H. A. Bethe, 1937, *Rev. Mod. Phys.* 9, 245.
- Maglich, B., 1975, *Adventures in Experimental Physics* (World Science Education, Princeton, N.J.), Vol. 4.
- Morrison, P., 1984, interview with S. S. Schweber, 9 August.
- Morse, P. M., 1977, *In at the Beginnings: A Physicist's Life* (MIT Cambridge, Mass.).
- Morse, P. M., and J. P. Vinti, 1933, Phys. Rev. 43, 337.
- Morse, P. M., L. A. Young, and E. S. Haurwitz, 1935, Phys. Rev. 48, 948.
- Nafe, J. E., E. B. Nelson, and I. I. Rabi, 1947, Phys. Rev. 71, 914.
- Opechowski, W., 1941, *Physica* 8, 161.
- Oppenheimer, J. R., 1930, Phys. Rev. 35, 461.
- Oppenheimer, J. R., 1943, letter to W. Pauli, 20 May in Smith, A. K. and C. Weiner, 1980, Eds., *Robert Oppenheimer, Letters and Recollections* (Harvard University, Cambridge, Mass.).
- Osgood, C. S., 1951, *Lights in Nassau Hall* (Princeton University, Princeton, N.J.).
- Pauli, W., 1949a, letter to J. Schwinger, 24 January, Oppenheimer Papers, Pauli Correspondence, The National Archives of the Library of Congress.
- Pauli, W., 1949b, letter to H. A. Bethe, 25 January, Bethe Papers, The Archives, Cornell University Library.
- Pauli, W., and F. Villars, 1949, *Rev. Mod. Phys.* 21, 434. Reprinted in Schwinger (1958).
- Plass, G. N., 1946, "Black Body Radiation in the Theory of Action at a Distance," Ph.D. thesis (Princeton University).
- Rainwater, W. J., I. I. Rabi, and W. W. Havens, Jr., 1949, Phys. Rev. 75, 1295(A).
- Schwarzschild, K., 1903, *Göttinger Nachr.* 128, 132.
- Schweber, S. S., 1984, in *Relativity, Groups and Topology II*, Les Houches Session XL, edited by B. S. DeWitt and R. Stora (North-Holland, Amsterdam).
- Schweber, S. S., 1985, in *Shelter Island II*, edited by R. Jackiw, N. N. Khuri, S. Weinberg, and E. Witten (MIT, Cambridge, Mass.).
- Schweber, S. S., 1986, *Osiris*, in press.
- Schwinger, J., 1948a, Phys. Rev. 73, 416. Reprinted in Schwinger (1958).
- Schwinger, J., 1948b, Phys. Rev. 74, 1439.
- Schwinger, J., 1949a, Phys. Rev. 75, 651.
- Schwinger, J., 1949b, Phys. Rev. 76, 790. Reprinted in Schwinger (1958).
- Schwinger, J., 1958, Ed., *Selected Papers on Quantum Electrodynamics* (Dover, New York).
- Schwinger, J., 1983, in *The Birth of Particle Physics*, edited by L. M. Brown and L. Hoddeson (Cambridge University, Cambridge, England).
- Schwinger, J., and V. F. Weisskopf, 1948, Phys. Rev. 73, 1271.
- Serpe, J., 1940, *Physica* 7, 133.
- Slater, J. C., 1969, in *In Honor of Philip M. Morse*, edited by H. Feshbach and K. V. Ingard (MIT, Cambridge, Mass.).
- Slater, J. C., and N. H. Frank, 1933, *Introduction to Theoretical Physics* (McGraw-Hill, New York).
- Slotnick, M., 1949, Phys. Rev. 75, 1295.
- Slotnick, M., and W. Heitler, 1949, Phys. Rev. 75, 1645.
- Smith, A. K., and C. Weiner, 1980, Eds., *Robert Oppenheimer. Letters and Recollections* (Harvard University, Cambridge, Mass.).
- Smyth, H. D., 1946, letter to R. P. Feynman, 23 October, RPF, CIT 2.48.\*
- Stückelberg, E. C. G., 1941a, "La Signification du Temps Propre en Mécanique Ondulatoire," *Helv. Phys. Acta* 14, 321.
- Stückelberg, E. C. G., 1941b, "Remarque à propos de la création de paire de particules en théorie de relativité," *Helv. Phys. Acta* 14, 588.
- Tetrode, H., 1922, *Z. Phys.* 10, 317.
- Tomonaga, S., 1943, *Bull. Inst. Phys. Chem. Res.* 22, 545.
- Tomonaga, S., 1946, *Prog. Theor. Phys.* 1, No. 2, 1. Reprinted in Schwinger (1958).
- Vallarta, M. S., and R. P. Feynman, 1939, Phys. Rev. 55, 506(L).
- Von Neumann, J., 1932, *Mathematische Grundlagen der Quantenmechanik* (Springer, Berlin).
- Waller, I., 1930, *Z. Phys.* 62, 673.
- Weinberg, S., 1977, *Dedalus*, fall 1977, 17; *Proc. Am. Acad. Arts Sci.* 106, No. 4, 17.
- Weisskopf, V. F. 1934a, *Z. Phys.* 89, 27.
- Weisskopf, V. F., 1934b, *Z. Phys.* 90, 817.
- Weisskopf, V. F., 1934c, letter to W. Furry, 20 August, Furry Papers, Archives, Pusey Library, Harvard University.
- Weisskopf, V. F., 1939, Phys. Rev. 56, 72. Reprinted in Schwinger (1958).
- Welton, T. A., 1983, "Memories of R. P. Feynman," 19 p. manuscript to S. S. Schweber, 3 November.
- Wheeler, J. A., 1937, Phys. Rev. 52, 1107.
- Wheeler, J. A., 1940, *Nuclear Physics*, notes by R. P. Feynman (Princeton University, Princeton, N.J.).
- Wheeler, J. A., 1941, letter to R. P. Feynman, November. RPF, CIT 3.10.\*
- Wheeler, J. A., 1942, letter to R. P. Feynman, 26 March. RPF,

## CIT 3.10.\*

- Wheeler, J. A., 1948, Ed., "Conference on Physics, Pocono Manor, Pennsylvania March 30—April 1, 1948. Sponsored by the National Academy of Science." Notes prepared and distributed "informally and unofficially."
- Wheeler, J. A., 1949, letter to R. P. Feynman, 10 November. RPF, CIT 3.10.\*
- Wheeler, J. A., 1967, interview with C. Weiner and G. Lubkin, 5 April, Niels Bohr Library, AIP, N.Y.
- Wheeler, J. A., 1979, in *Nuclear Physics in Retrospect, Proceedings of a Symposium on the 1930s*, edited by R. H. Stuewer (University of Minnesota, Minneapolis), p. 217.
- Wheeler, J. A., 1981, interview with S. S. Schweber, 15 August.
- Wheeler, J. A., and R. P. Feynman, 1942, "Action at a Distance in Classical Theory." Richard Feynman papers, Niels Bohr Library, AIP, N.Y.
- Wheeler, J. A., and R. P. Feynman, 1945, *Rev. Mod. Phys.* **17**, 157.
- Wightman, A. S., 1947, notes "Quantum Field Theory 1947." In the possession of A. S. Wightman.
- Wigner, E., P., 1946, letter to R. P. Feynman, 26 February. RPF, CIT 3.11.\*
- Wigner, E. P., 1947, *Physical Science and Human Values* (Princeton University, Princeton, N.J.).
- Wigner, E. P., 1981, interview with S. S. Schweber, 15 August.
- Wilson, R. R., 1979, in *Nuclear Physics in Retrospect: Proceedings of a Symposium on the 1930s*, edited by R. H. Stuewer (University of Minnesota, Minneapolis), p. 214.



FIG. 1. Participants at the Shelter Island conference (left to right): I. I. Rabi, L. Pauling, J. Van Vleck, W. E. Lamb, G. Breit, D. MacInnes, K. K. Darrow, G. E. Uhlenbeck, J. Schwinger, E. Teller, B. Rossi, A. Nordsieck, J. von Neumann, J. A. Wheeler, H. A. Bethe, R. Serber, R. E. Marshak, A. Pais, J. R. Oppenheimer, D. Bohm, R. P. Feynman, V. F. Weisskopf, H. Feshbach (not in the picture, H. A. Kramers). Courtesy of the Archives of the National Academy of Sciences.



FIG. 10. W. Lamb, A. Pais, R. Feynman, H. Feshbach, and J. Schwinger conferring during the Shelter Island conference. J. A. Wheeler is standing against the wall. Courtesy of AIP Niels Bohr Library.



FIG. 11. From left to right: standing—W. Lamb, K. K. Darrow, V. Weisskopf, G. E. Uhlenbeck, R. E. Marshak, J. Schwinger, and D. Bohm. Seated—J. R. Oppenheimer, A. Pais, R. P. Feynman, and H. Feshbach. Courtesy of Archives of the National Academy of Sciences.