

Electron tunneling and superconductivity*

Ivar Giaever

General Electric Research and Development Center, Schenectady, New York

In my laboratory notebook dated May 2, 1960 is the entry: "Friday, April 22, I performed the following experiment aimed at measuring the forbidden gap in a superconductor." This was obviously an extraordinary event not only because I rarely write in my notebook, but because the success of that experiment is the reason I have the great honor and pleasure of addressing you today. I shall try in this lecture, as best I can, to recollect some of the events and thoughts that led to this notebook entry, though it is difficult to describe what now appears to me as fortuitous. I hope that this personal and subjective recollection will be more interesting to you than a strictly technical lecture, particularly since there are now so many good review articles dealing with superconductive tunneling.¹

A recent headline in an Oslo paper read approximately as follows: "Master in billiards and bridge, almost flunked physics—gets Nobel Prize. The paper refers to my student days in Trondheim. I have to admit that the reporting is reasonably accurate. Therefore I shall not attempt a "cover up," but confess that I almost flunked in mathematics as well. In those days I was not very interested in mechanical engineering and school in general, but I did manage to graduate with an average degree in 1952. Mainly because of the housing shortage which existed in Norway, my wife and I finally decided to emigrate to Canada where I soon found employment with Canadian General Electric. A three year Company course in engineering and applied mathematics known as "the A, B and C course" was offered to me. I realized this time that school was for real, and since it probably would be my last chance, I really studied hard for a few years.

When I was 28 years old I found myself in Schenectady, New York, where I discovered that it was possible for some people to make a good living as physicists. I had worked on various Company assignments in applied mathematics, and had developed the feeling that the mathematics was much more advanced than the actual knowledge of the physical systems that we applied it to. Thus, I thought perhaps I should learn some physics and, even though I was still an engineer, I was given the opportunity to try it at the General Electric Research Laboratory.

The assignment I was given was to work with thin films, and to me films meant photography. However I was fortunate to be associated with John Fisher who obviously had other things in mind. Fisher had started out as a mechanical engineer as well, but had lately turned his attention towards theoretical physics. He had the notion that useful electronic devices could be made using thin film technology, and before long I was working with metal films separated by thin insulating layers,

trying to do tunneling experiments. I have no doubt that Fisher knew about Leo Esaki's tunneling experiments at that time, but I certainly did not. The concept that a particle can go through a barrier seemed sort of strange to me, just struggling with quantum mechanics at Rensselaer Polytechnic Institute in Troy, where I took formal courses in Physics. For an engineer it sounds rather strange that if you throw a tennis ball against a wall enough times it will eventually go through without damaging either the wall or itself. That must be the hard way to a Nobel Prize! The trick, of course, is to use very tiny balls, and lots of them. Thus if we could place two metals very close together without making a short, the electrons in the metals can be considered as the balls and the wall is represented by the spacing between the metals. These concepts are shown in Fig. 1. While classical mechanics correctly predicts the behavior of large objects such as tennis balls, to predict the behavior of small objects such as electrons we must use quantum mechanics. Physical insight relates to everyday experiences with large objects, thus we should not be too surprised that electrons sometimes behave in strange and unexpected ways.

Neither Fisher nor I had much background in experimental physics, none to be exact, and we made several false starts. To be able to measure a tunneling current the two metals must be spaced no more than about 100Å apart, and we decided early in the game not to attempt to use air or vacuum between the two metals because of problems with vibration. After all, we both had training in mechanical engineering! We tried instead to keep the two metals apart by using a variety of thin insulators made from Langmuir films and from Formvar. Invariably, these films had pinholes and the mercury counter electrode which we used would short the films. Thus we spent some time measuring very interesting but always nonreproducible current-voltage characteristics which we referred to as miracles since each occurred only once. After a few months we hit on the correct idea: to use evaporated metal films and to separate them by a naturally grown oxide layer.

To carry out our ideas we needed an evaporator, thus I purchased my first piece of experimental equipment. While waiting for the evaporator to arrive I worried a lot—I was afraid I would get stuck in experimental physics tied down to this expensive machine. My plans at the time were to switch into theory as soon as I had acquired enough knowledge. The premonition was correct; I did get stuck with the evaporator, not because it was expensive, but because it fascinated me. Figure 2 shows a schematic diagram of an evaporator. To prepare a tunnel junction we first evaporated a strip of aluminum onto a glass slide. This film was removed from the vacuum system and heated to oxidize the surface rapidly. Several cross strips of aluminum were then deposited over the first film making several junctions at the same time. The steps in the sample preparation are illustrated in Fig. 3. This procedure solved two problems: First, there were no pinholes in the oxide because it is self-healing, and second, we got rid of mechanical problems

* This lecture was delivered by Ivar Giaever on the occasion of his receiving the 1973 Nobel Prize in Physics. © The Nobel Foundation 1974.

¹ See, for example, *Tunneling Phenomena in Solids*, 1969, edited by E. Burstein and S. Lundquist (Plenum Press, New York); *Superconductivity*, 1969, edited by R. D. Parks (Marcel Dekker, New York).

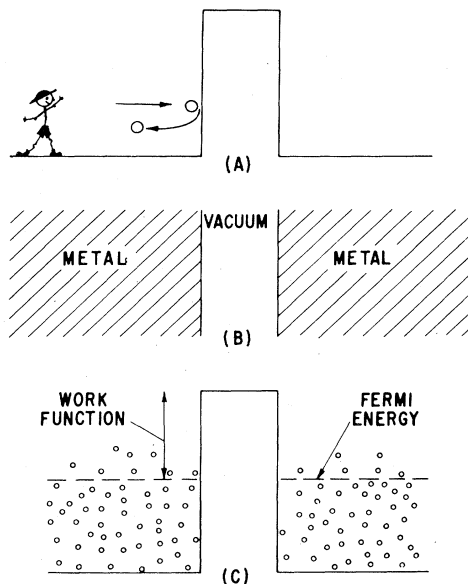

FIG. 1. If a man throws a ball against a wall, the ball bounces back. The laws of physics allow the ball to penetrate or tunnel through the wall, but the chance is infinitesimally small because the ball is a macroscopic object. (b) Two metals separated by a vacuum will approximate the above situation. The electrons in the metals are the "balls"; the vacuum represents the wall.

that arose with the mercury counter electrode.

By about April, 1959, we had performed several successful tunneling experiments. The current-voltage characteristics of our samples were reasonably reproducible, and conformed well to theory. A typical result is shown in Fig. 4. Several checks were done, such as varying the area and the oxide thickness of the junction as well as changing the temperature. Everything looked okay, and I even gave a seminar at the Laboratory. By this time, I had solved Schrödinger's equation enough times to believe that electrons sometimes behave as waves, and I did not worry much about that part anymore.

However, there were many real physicists at the Labo-

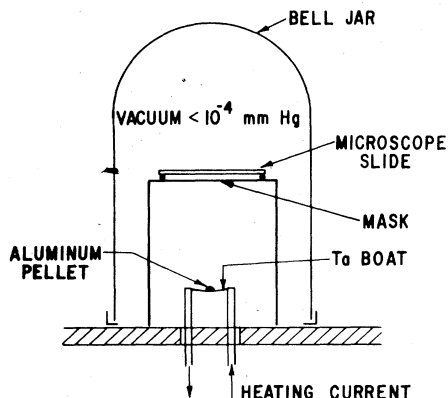

FIG. 2. A schematic drawing of a vacuum system for depositing metal films. For example, if aluminum is heated resistively in a tantalum boat, the aluminum first melts, then boils and evaporates. The aluminum vapor will solidify on any cold substrate placed in the vapor stream. The most common substrates are ordinary microscope glass slides. Patterns can be formed on the slides by suitably shielding them with a metal mask.

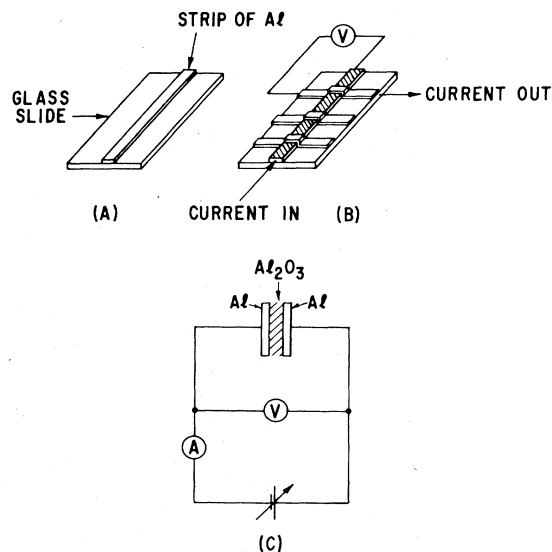

FIG. 3. (a) A microscope glass slide with a vapor deposited aluminum strip down the middle. As soon as the aluminum film is exposed to air, a protective insulating oxide forms on the surface. The thickness of the oxide depends upon such factors as time, temperature and humidity. (b) After a suitable oxide has formed, cross strips of aluminum are evaporated over the first film, sandwiching the oxide between the two metal films. Current is passed along one aluminum film up through the oxide and out through the other film, while the voltage drop is monitored across the oxide. (c) A schematic circuit diagram. We are measuring the current-voltage characteristics of the capacitorlike arrangement formed by the two aluminum films and the oxide. When the oxide thickness is less than 50\AA or so, an appreciable dc current will flow through the oxide.

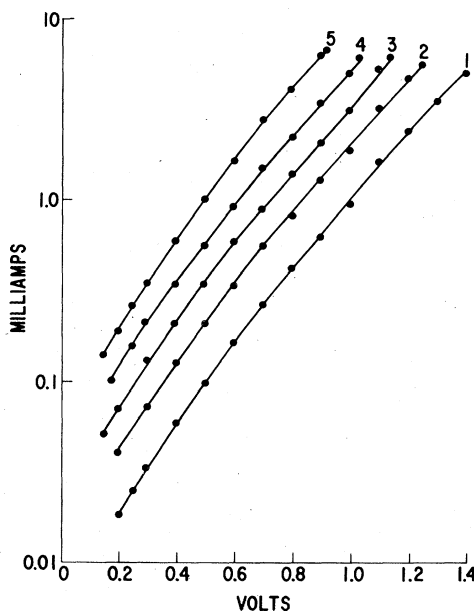

FIG. 4. Current-voltage characteristics of five different tunnel junctions, all with the same thickness, but with five different areas. The current is proportional to the area of the junction. This was one of the first clues that we were dealing with tunneling rather than shorts. In the early experiments we used a relatively thick oxide; thus very little current would flow at low voltages.

ratory and they properly questioned my experiment. How did I know I did not have metallic shorts? Ionic current? Semiconduction rather than tunneling? Of course, I did not know, and even though theory and experiments agreed well, doubts about the validity were always in my mind. I spent a lot of time inventing impossible schemes such as a tunnel triode or a cold cathode, both to try to prove conclusively that I dealt with tunneling and to perhaps make my work useful. It was rather strange for me at that time to get paid for doing what I considered having fun, and my conscience bothered me. But just like quantum mechanics, you get used to it, and now I often argue the opposite point; we should pay more people to do pure research.

I continued to try out my ideas on John Fisher who was now looking into the problems of fundamental particles with his characteristic optimism and enthusiasm; in addition, I received more and more advice and guidance from Charles Bean and Walter Harrison, both physicists with the uncanny ability of making things clear as long as a piece of chalk and a blackboard were available. I continued to take formal courses at Rensselaer Polytechnic Institute, and one day in a solid state physics course taught by Professor Huntington we got to superconductivity. Well, I didn't believe that the resistance drops to exactly zero—but what really caught my attention was the mention of the energy gap in a superconductor, central to the new Bardeen-Cooper-Schrieffer theory. If the theory was any good and if my

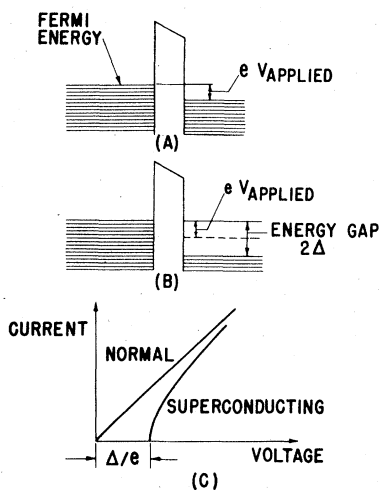

FIG. 5. (a) An energy diagram of two metals separated by a barrier. The Fermi energies in the two metals are at different levels because of the voltage difference applied between the metals. Only the left metal electrons in the energy range $e \cdot V_{app}$ can make a transition to the metal on the right, because only these electrons face empty energy states. The Pauli Principle allows only one electron in each quantum state. (b) The right-hand metal is now superconducting, and an energy gap 2Δ has opened up in the electron spectrum. No single electron in a superconductor can have an energy such that it will appear inside the gap. The electrons from the metal on the left can still tunnel through the barrier, but they cannot enter into the metal on the right as long as the applied voltage is less than Δ/e , because the electrons either face a filled state or a forbidden energy range. When the applied voltage exceeds Δ/e , current will begin to flow. (c) A schematic current-voltage characteristic. When both metals are in the normal state the current is simply proportional to the voltage. When one metal is superconducting the current-voltage characteristic is drastically altered. The exact shape of the curve depends on the electronic energy spectrum in the superconductor.

tunneling experiments were any good, it was obvious to me that by combining the two, some pretty interesting things should happen, as illustrated in Fig. 5. When I got back to the GE Laboratory I tried this simple idea out on my friends, and as I remember, it did not look as good to them. The energy gap was really a many-body effect and could not be interpreted literally the way I had done. But even though there was considerable skepticism, everyone urged me to go ahead and make a try. Then I realized that I did not know what the size of the gap was in units I understood—electron volts. This was easily solved by my usual method: first asking Bean and then Harrison, and, when they agreed on a few millielectron volts, I was happy because that is in an easily measured voltage range.

I had never done an experiment requiring low temperatures and liquid helium—that seemed like a complicated business. However one great advantage of being associated with a large laboratory like General Electric is that there are always people around who are knowledgeable in almost any field, and better still they are willing to lend you a hand. In may case, all I had to do was go to the end of the hall where Warren DeSorbo was already doing experiments with superconductors. I no longer remember how long it took me to set up the helium Dewars I borrowed, but probably no longer than a day or two. People unfamiliar with low temperature work believe that the whole field of low temperature is pretty esoteric, but all it really requires is access to liquid helium which was readily available at the Laboratory. The experimental setup is shown in Fig. 6. Then I made my samples using the familiar aluminum-aluminum oxide, but I put lead

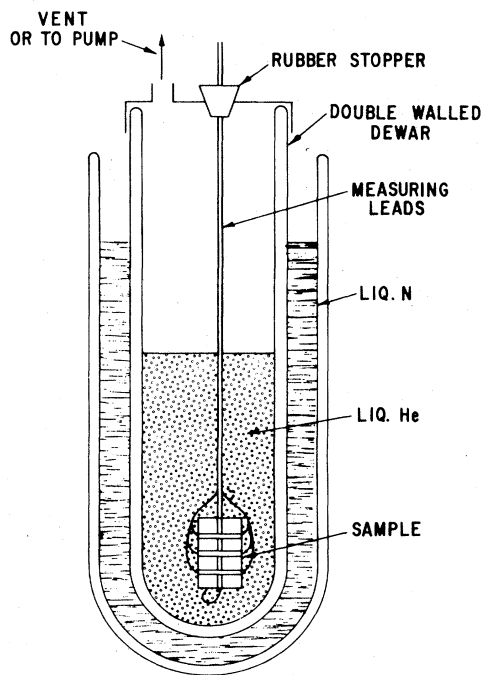

FIG. 6. A standard experimental arrangement used for low temperature experiments. It consists of two Dewars, the outer one containing liquid nitrogen, the inner one consisting of liquid helium. Helium boils at 4.2°K at atmospheric pressure. The temperature can be lowered to about 1°K by reducing the pressure. The sample simply hangs into the liquid helium supported by the measuring leads.

strips on top. Both lead and aluminum are superconductors. Lead is superconducting at 7.2° K and thus all you need to make it superconducting is liquid helium which boils at 4.2° K. Aluminum becomes superconducting only below 1.2° K, and to reach this temperature a more complicated experimental setup is required.

The first two experiments I tried were failures because I used oxide layers which were too thick. I did not get enough current through the thick oxide to measure it reliably with the instruments I used, which were simply a standard voltmeter and a standard ammeter. It is strange to think about that now, only 13 years later, when the Laboratory is full of sophisticated x - y recorders. Of course, we had plenty of oscilloscopes at that time but I was not very familiar with their use. In the third attempt rather than deliberately oxidizing the first aluminum strip, I simply exposed it to air for only a few minutes, and put it back in the evaporator to deposit the cross strips of lead. This way the oxide was no more than about 30Å thick, and I could readily measure the current-voltage characteristic with the available equipment. To me the greatest moment in an experiment is always just before I learn whether the particular idea is a good or a bad one. Thus even a failure is exciting, and most of my ideas have of course been wrong. But this time it worked! The current-voltage characteristic changed markedly when the lead changed from the normal state to the superconducting state as shown in Fig. 7. That was exciting! I immediately repeated the experiment using a

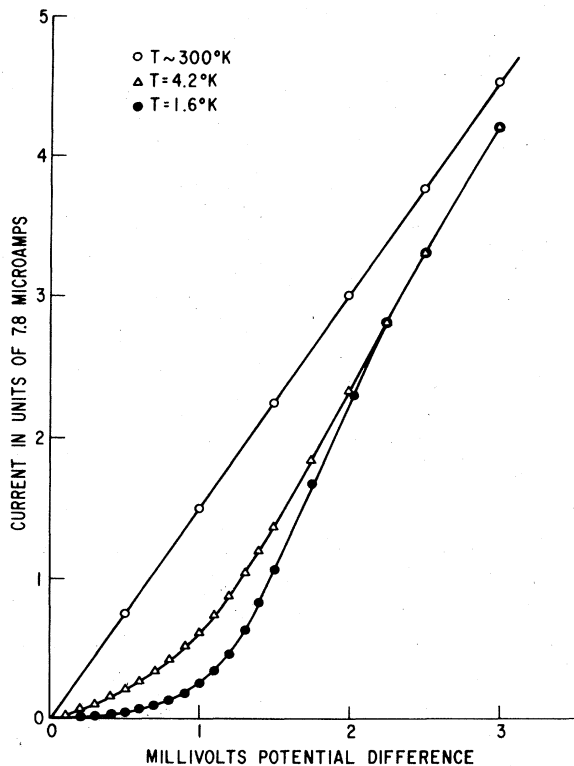

FIG. 7. The current-voltage characteristic of an aluminum-aluminum oxide-lead sample. As soon as the lead becomes superconducting the current ceases to be proportional to the voltage. The large change between 4.2° K and 1.6° K is due to the change in the energy gap with temperature. Some current also flows at voltages less than Δ/e because of thermally excited electrons in the conductors.

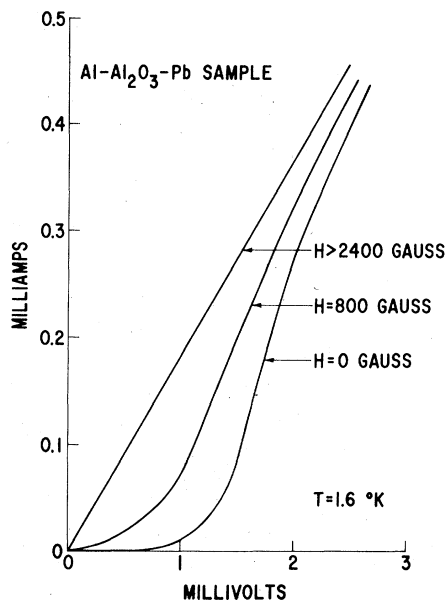

FIG. 8. The current-voltage characteristic at 1.6° K as a function of the applied magnetic field. At 2400 G the films are normal, at 0 G the lead film is superconducting. The reason for the change in the characteristics between 800 G and 0 G is that thin films have an energy gap that is a function of the magnetic field.

different sample—same results! Another sample—still the same results—everything looked good! But how to make certain? It was well known that superconductivity is destroyed by a magnetic field, but my simple setup of Dewars made that experiment impossible. This time I had to go all the way across the hall where Israel Jacobs studied magnetism at low temperatures. Again I was lucky enough to go right into an experimental rig where both the temperature and the magnetic field could be controlled and I could quickly do all the proper experiments. The basic result is shown in Fig. 8. Everything held together and the whole group, as I remember it, was very excited. In particular, I can remember Bean enthusiastically spreading the news up and down the halls in our Laboratory, and also patiently explaining to me the



FIG. 9. Informal discussion over a cup of coffee. From left: Ivar Giaever, Walter Harrison, Charles Bean, and John Fisher.

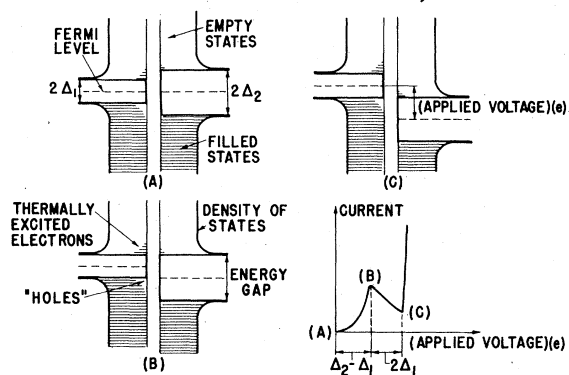

FIG. 10. Tunneling between two superconductors with different energy gaps at a temperature larger than 0°K . (a) No voltage is applied between the two conductors. (b) As a voltage is applied it becomes energetically possible for more and more of the thermally excited electrons to flow from the superconductor with the smaller gap into the superconductor with the larger gap. At the voltage shown all the excited electrons can find empty states on the right. (c) As the voltage is further increased, no more electrons come into play, and since the number of states they can tunnel into decreases, the current will decrease as the voltage is increased. When the voltage is increased sufficiently the electrons below the gap in the superconductor on the left face empty states on the right, and a rapid increase in current will occur. (d) A schematic picture of the expected current-voltage characteristic.

significance of the experiment.

I was, of course, not the first person to measure the energy gap in a superconductor, and I soon became aware of the nice experiments done by Tinkham and his students using infrared transmission. I can remember that I was worried that the size of the gap that I measured did not quite agree with those previous measurements. Bean set me straight with words to the effect that from then on other people would have to agree with me; my experiment would set the standard, and I felt pleased and like a physicist for the first time.

That was a very exciting time in my life; we had several great ideas to improve and extend the experiment to all sorts of materials like normal metals, magnetic materials, and semiconductors. I remember many informal discussions over coffee about what to try next, and one of these sessions is in a photograph taken in 1960 which is shown in Fig. 9. To be honest the picture was staged, we weren't normally so dressed up, and rarely did

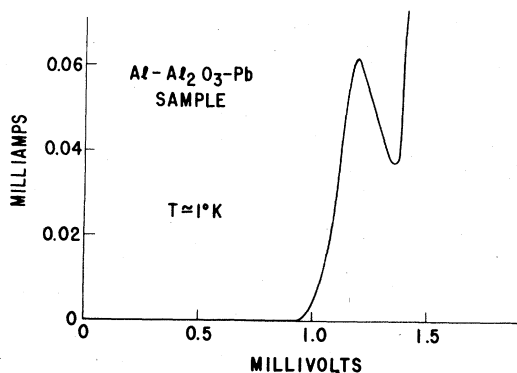

FIG. 11. A negative resistance characteristic obtained experimentally in tunneling between two different superconductors.

I find myself in charge at the blackboard! Most of the ideas we had did not work very well, and Harrison soon published a theory showing that life is really complicated after all. But the superconducting experiment was charmed and always worked. It looked like the tunneling probability was directly proportional to the density of states in a superconductor. Now if this were strictly true, it did not take much imagination to realize that tunneling between two superconductors should display a negative resistance characteristic as illustrated in Fig. 10. A negative resistance characteristic meant, of course, amplifiers, oscillators, and other devices. But nobody around me had facilities to pump on the helium sufficiently to make aluminum become superconducting. This time I had to leave the building and reactivate an old low-temperature setup in an adjacent building. Sure enough, as soon as the aluminum went superconducting a negative resistance appeared, and, indeed, the notion that the tunneling probability was directly proportional to the density of states was experimentally correct. A typical characteristic is shown in Fig. 11.

Now things looked very good because all sorts of electronic devices could be made using this effect, but, of course, they would only be operative at low temperatures. We should remember that the semiconducting devices were not so advanced in 1960 and we thought that the superconducting junction would have a good chance of competing with, for example, the Esaki diode. The basic question I faced was which way to go: engineering or science? I decided that I should do the science first, and received full support from my immediate manager, Roland Schmitt.

In retrospect I realize how tempting it must have been for Schmitt to encourage other people to work in the new area, and for the much more experienced physicists around me to do so as well. Instead, at the right time, Schmitt provided me with a co-worker, Karl Megerle, who joined our Laboratory as a Research Training Fellow. Megerle and I worked well together and before long we published a paper dealing with most of the basic effects.

As always in physics, it is important to extend experiments to a higher energy, a greater magnetic field, or, in our case, to a lower temperature. Therefore, we joined forces with Howard Hart, who had just completed a helium-3 refrigerator that was capable of getting down to about 0.3°K . At the same time, Megerle finished a lock-in amplifier which we could use to measure directly the derivative of the current with respect to the voltage. That was really a nice looking machine with a magnet rotating past a pickup coil at eight cycles per second, but, of course, vastly inferior to the modern lock-in amplifier. We had known for some time that there were anomalies in the current-voltage characteristics of lead, and now we finally pinned them down by finding some extra wiggles in the derivative curve. This is shown in Fig. 12. That made us happy because all that the tunneling experiments had done up till now was to confirm the BCS theory, and that is not what an experimentalist would really like to do. The dream is to show that a famous theory is incorrect, and now we had finally poked a hole in the theory. We speculated at the time that these wiggles were somehow associated with the phonons thought to be the cause of the attractive electron-electron interaction in a superconductor. As often happens, the

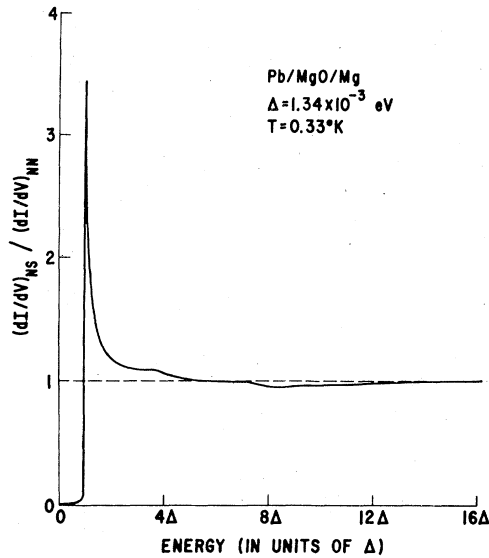

FIG. 12. A normalized derivative of the current with respect to voltage of a lead junction at low temperature. The simple BCS theory predicts that the derivative should approach unity asymptotically as the energy increases. Instead, several wiggles are observed in the range between 4Δ and 8Δ . These wiggles are related to the photon spectrum in lead.

theorists turned the tables on us and cleverly used these wiggles to properly extend the theory and to prove that the BCS theory indeed was correct. Professor Bardeen gave a detailed account of this in his most recent Nobel Prize lecture.

I have, so far, talked mainly about what went on at General Electric at that time; sometimes it is difficult for me to realize that Schenectady is not the center of the world. Several other people began to do tunneling work, and to mention just a few: J. M. Rowell and W. L. McMillan were really the ones who unraveled the phonon structure in a superconductor; W. J. Tomasz, of course, insisted on discovering his own effect; S. Shapiro and colleagues did tunneling between two superconductors at the same time we did; and J. Bardeen, and later M. H. Cohen *et al.*, took care of most of the theory.

Meanwhile, back at RPI, I had finished my course work and decided to do a theoretical thesis on ordered-disordered alloys with Professor Huntington because tunneling in superconductors was mainly understood. Then someone made me aware of a short paper by Brian Josephson in *Physics Letters*—what did I think? Well, I did not understand the paper, but shortly after I had the chance to meet Josephson at Cambridge and I came away impressed. One of the effects Josephson predicted was that it should be possible to pass a supercurrent with zero voltage drop through the oxide barrier when the metals on both sides were superconducting; this is now called the dc Josephson effect. We had observed this behavior many times; matter of fact, it is difficult not to see this current when junctions are made of tin-tin oxide-tin or lead-lead oxide-lead. The early tunnel junctions were usually made with aluminum oxide which

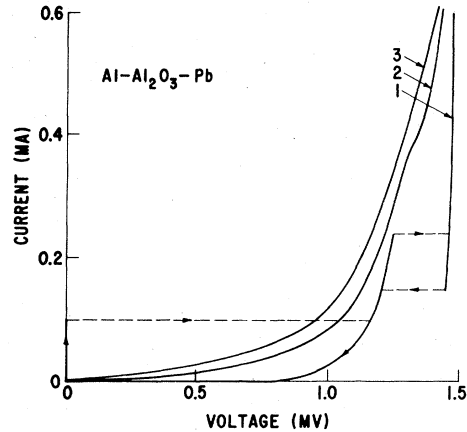

FIG. 13. Effect of trapped magnetic field on a tunneling characteristic. Curve 1 is a virgin curve, while Curve 3 is in a moderate magnetic field, and in Curve 2 the magnetic field has been removed. In Curve 1 we also have a small resistanceless current which we interpreted as caused by metallic shorts. In retrospect, it was actually due to the Josephson effect.

generally is thicker and therefore thermal fluctuations suppress the dc current. In our first paper Megerle and I published a curve, which is shown in Fig. 13, demonstrating such a supercurrent and also that it depended strongly on a magnetic field. However, I had a ready-made explanation for this supercurrent—it came from a metallic short or bridge. I was puzzled at the time because of the sensitivity to the magnetic field which is unexpected for a small bridge, but no one knew how a 20\AA long and 20\AA wide bridge would behave anyway. If I have learned anything as a scientist it is that one should not make things complicated when a simple explanation will do. Thus all the samples we made showing the Josephson effect were discarded as having shorts. This time I was too simple-minded! Later I have been asked many times if I feel bad for missing the effect? The answer is clearly no, because to make an experimental discovery it is not enough to observe something, one must also realize the significance of the observation, and in this instance I was not even close. Even after I learned about the dc Josephson effect, I felt that it could not be distinguished from real shorts, therefore I erroneously believed that only the observation of the so-called ac effect would prove or disprove Josephson's theory.

In conclusion I hope that this rather personal account may provide some slight insight into the nature of scientific discovery. My own beliefs are that the road to a scientific discovery is seldom direct, and that it does not necessarily require great expertise. In fact, I am convinced that often a newcomer to a field has a great advantage because he is ignorant and does not know all the complicated reasons why a particular experiment should not be attempted. However, it is essential to be able to get advice and help from experts in the various sciences when you need it. For me the most important ingredients were that I was at the right place at the right time and that I found so many friends both inside and outside General Electric who unselfishly supported me.

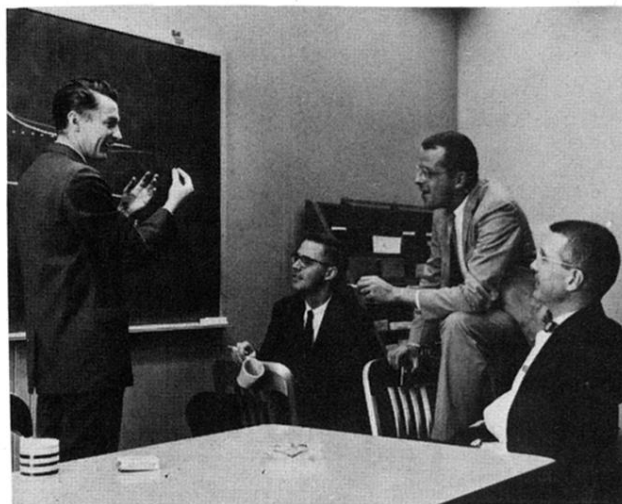

FIG. 9. Informal discussion over a cup of coffee. From left: Ivar Giaever, Walter Harrison, Charles Bean, and John Fisher.