

Overview of the Compact Linear Collider

R. Tomás*

CERN, CH 1211 Geneva 23, Switzerland

(Received 14 August 2009; published 11 January 2010)

The CLIC study is exploring the scheme for an electron-positron collider with a center-of-mass energy of 3 TeV in order to make the multi-TeV range accessible for lepton physics. The current goal of the project is to demonstrate the feasibility of the technology by the year 2010. Recently, important progress has been made concerning the high-gradient accelerating structure tests and the experiments with beam in the CLIC test facility, CTF3. Several important aspects of the project are dealt with through international collaborations, which has considerably boosted the CLIC study.

DOI: [10.1103/PhysRevSTAB.13.014801](https://doi.org/10.1103/PhysRevSTAB.13.014801)

PACS numbers: 29.20.Ej, 01.52.+r

I. INTRODUCTION

Electron-positron linear colliders are considered as the most desirable HEP facility to complement the LHC in the future. Two alternative linear collider projects are presently being developed, the International Linear Collider (ILC), based on superconducting technology in the TeV range, and the Compact Linear Collider (CLIC), based on the novel approach of two beam acceleration to extend linear colliders into the multi-TeV range. These two studies are complementary in the preparation for the most appropriate facility after the LHC era. The choice will be based on the respective maturity of each technology and on the physics requests derived from the LHC physics results when available. A close CLIC/ILC collaboration has been established on subjects with strong synergies in different working groups [1].

CLIC aims to collide electrons and positrons at a center-of-mass energy of 3 TeV with a luminosity of $2 \times 10^{34} \text{ cm}^{-2} \text{ s}^{-1}$, see [2–6]. To accomplish this at a reasonable cost, the CLIC study proposes a two beam accelerating scheme featuring an accelerating gradient in the presence of beam (loaded) in the order of 100 MV/m. The rf power for acceleration is extracted from a low-energy but high-intensity beam (the drive beam) and fed into the main beam via copper structures. Figure 1 and Table I display the layout and parameters of the CLIC complex at 3 TeV. The drive and main beam lines occupy the top and bottom halves of the plot, respectively. The current CLIC study foresees only one interaction point. The facility would be built in phases with a first phase in the TeV energy range. The initial center-of-mass energy has been arbitrarily chosen to be 500 GeV to allow a direct comparison with ILC. However, this energy will eventually be defined from the physics requests. The upgrade path from this lower energy machine has not been fully studied yet. It is assumed that the entire beam delivery system (BDS) and part of the detector will need to be rebuilt.

However, the 500 GeV linac could in principle be used in the high energy machine.

The CLIC study is presently in an R&D phase having established an international collaboration where 33 institutes [7] and many facilities around the world are exploring technological frontiers to assess the CLIC feasibility. Significant R&D is still required to demonstrate the CLIC feasibility. This effort will result by the end of 2010 in the conceptual design report (CDR). This CDR will document the CLIC complex and the concepts for the technical realization of all subsystems with a first cost estimate. The technical subsystems have been reviewed and a prioritized list of the “critical items” has been established as follows: (i) accelerating structures at 100 MV/m; (ii) power extraction and transfer structures (PETS); (iii) two beam acceleration and module integration; (iv) generation of the 100 A drive beam with 12 GHz bunch frequency, meeting the phase, energy, and intensity stability tolerances; (v) rf power generation by drive beam; (vi) generation and preservation of the main beam low emittances from the damping rings to the final focus; (vii) active alignment and stabilization of main quadrupoles to 1 nm (for frequencies above 1 Hz) and of the final doublet (FD) quadrupoles to 0.15 nm (for frequencies above 4 Hz); (viii) operation and machine protection; (ix) conditions for the experiments.

In the following the CLIC complex subsystems are briefly described with emphasis on their technical challenges and the related existing experimental facilities.

II. INJECTION COMPLEX

The injection complex generates 2.4 GeV polarized e^- and 2.4 GeV unpolarized e^+ with bunch populations of 6×10^9 particles [8]. Roughly 30% of these particles are produced in excess in order to cope with downstream losses. The e^+ are generated by shooting 5 GeV e^- on hybrid targets. The experimental feasibility of the polarized e^- source is investigated via collaborations with JLAB and SLAC while studies of unpolarized and polar-

*For the CLIC study team.

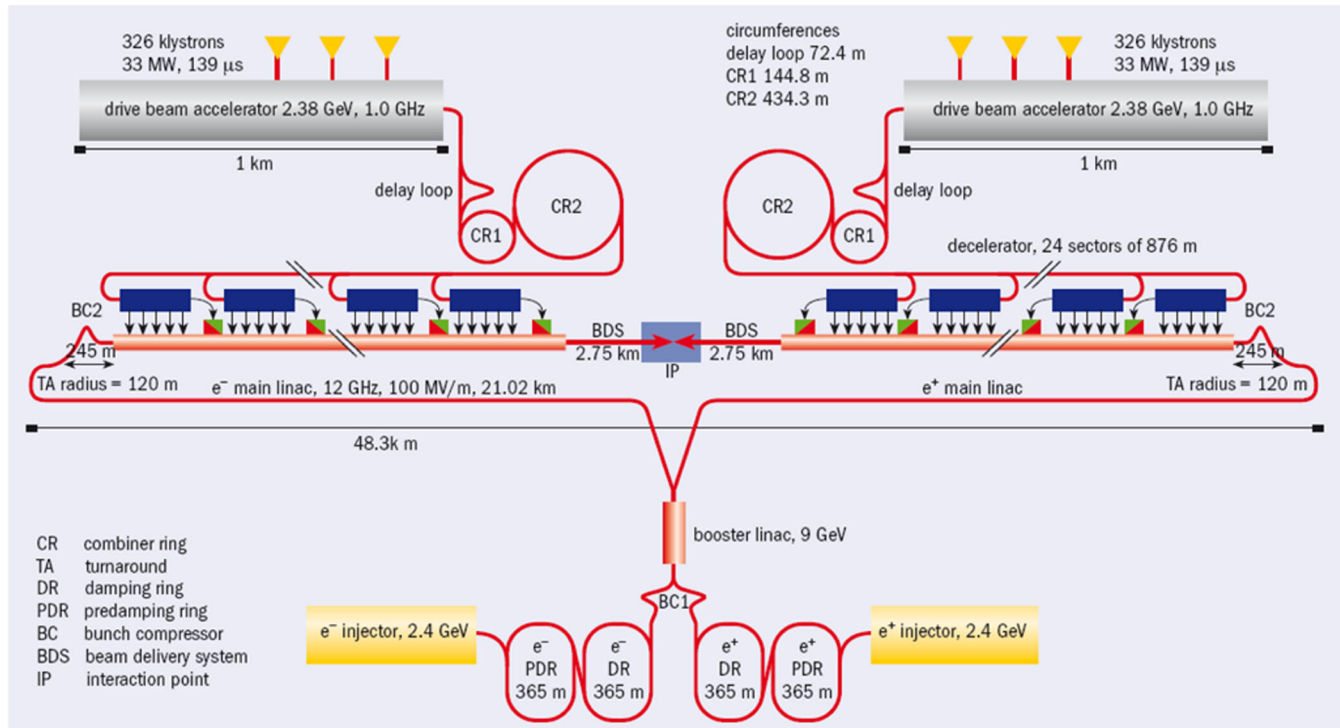

FIG. 1. (Color) The CLIC layout for 3 TeV (not to scale).

ized e^+ sources [9] (possibly based on Compton scattering) are investigated via collaborations with LAL, KEK, ANL, and Cockcroft Institute. A CLIC/ILC e^+ generation working group has been set up [1]. The sources are challenged by the CLIC parameters at 500 GeV since the bunch charge is doubled, at the sources, compared to the 3 TeV study.

TABLE I. CLIC main parameters for the 3 TeV and the 500 GeV options.

	CLIC 3 TeV	CLIC 500 GeV	Unit
Center-of-mass energy	3	0.5	TeV
Luminosity (in 1% energy)	2	1.4	$10^{34} \text{ cm}^{-2} \text{ s}^{-1}$
Main linac rf frequency	12	12	GHz
Gradient (loaded)	100	80	MV/m
Linac repetition rate	50	50	Hz
Number of particles per bunch	3.72	6.8	10^9
Bunch separation	0.5	0.5	ns
Number of bunches per train	312	354	
Beam power	14	4.9	MW
Proposed site length	48.3	12.8	km
AC to beam power efficiency	7.1	7.5	%
Total site AC power	392	130	MV
Normalized horizontal emittance	660	2400	nm
Normalized vertical emittance	20	25	nm
Horizontal IP β	6.9	8	mm
Vertical IP β	0.07	0.1	mm

III. DAMPING RINGS

The 2.42 GeV damping and predamping rings (DR and PDR) have the challenge to generate smaller emittances than ever achieved, namely $\gamma\epsilon_x = 500 \text{ nm}$ and $\gamma\epsilon_y = 5 \text{ nm}$ [10]. This requires the DRs to operate in a new regime where the synchrotron light emitted in the superconducting wigglers [11] is the main source of radiation damping. Figure 2 compares the geometrical emittances of the CLIC DR to present and future projects, showing the

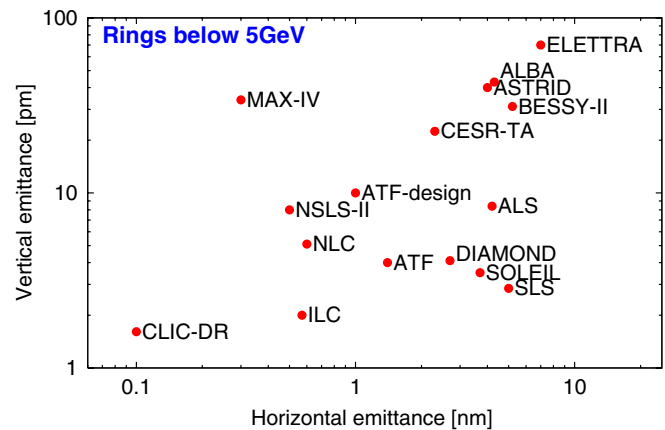

FIG. 2. (Color) Chart of vertical versus horizontal geometric emittances for different projects with energies below 5 GeV, showing the challenge to generate the CLIC DR emittances at 3 TeV.

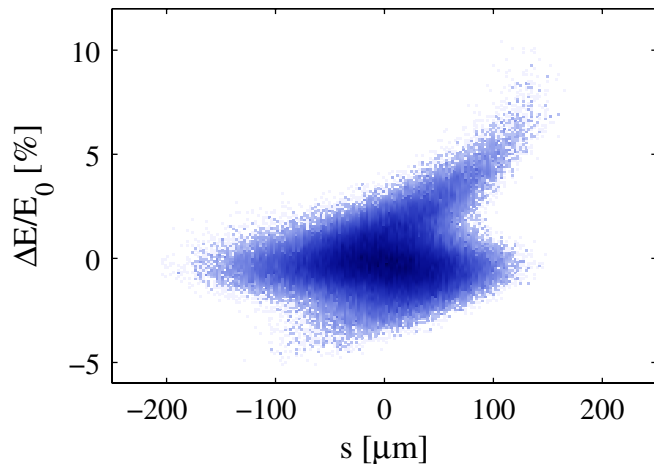

FIG. 3. (Color) Longitudinal phase space of the bunch after tracking through the entire RTML.

challenge. The DR features an energy loss per turn of 3.9 MeV with an rf voltage of 5 MV, a bunch length of 1.4 mm, and an energy spread of 0.1%. Its energy acceptance of 2.6% is comparable to existing light sources. The DRs face unexplored regimes of intrabeam scattering [12] and other collective effects as fast-ion instability [13] and electron cloud [14]. It is possible to alleviate the effect of intrabeam scattering by increasing the energy to 2.86 GeV [15]. To avoid the fast-ion instability the vacuum should be 0.1 nTorr. The electron cloud in the e^+ DR could be mitigated by the use of special carbon coating developed in CERN [16] that reduces the secondary emission yield below 1. Experimental tests with this new carbon coating are being performed in SPS and CESR-TA to verify its performance [17].

Thanks to the CLIC/ILC collaboration many DRs critical points will be jointly addressed by experts from both projects and via dedicated experiments in ATF and CESR-TA. Concerning the generation of the very low emittances CLIC should rely on the experience of the future light sources as NSLS-II or MAX-IV that will come a step closer to the CLIC DR horizontal emittance, see Fig. 2.

IV. RTML

The ring to main linac (RTML) section takes the beams from the DRs on the ground down to the tunnel for injection

in the main linac [18]. It consists of a booster linac that accelerates the beams to 9 GeV, two bunch compressors with a total compression factor of about 30 (final bunch length being 0.044 mm), a 21 km transfer line [19], and an isochronous and achromatic turn around loop. Incoherent synchrotron radiation (ISR) in the turn around loop is the dominant source of emittance dilution in this section.

For the first time tracking studies through the entire RTML have been performed [20]. Figure 3 shows the negligible longitudinal deformation of a Gaussian 8 GeV beam at the end of the RTML. Since the emittance growth is more severe at the design energy of 9 GeV, it has been proposed to reduce the energy to 8 GeV in order to alleviate the emittance growth due to ISR in the turn around loop. Vacuum levels in the long transfer line of the RTML should be kept in the order of 0.1 nTorr to avoid the fast-ion instability [21].

V. DRIVE BEAM COMPLEX

The drive beam is generated as a long train of e^- bunches with a large bunch spacing of 60 cm. It is accelerated to an energy of 2.38 GeV using conventional klystron amplifiers at 1 GHz in a normal conducting linac. To optimize the efficiency, the rf cavities operate under full beam loading condition, where 95% of the rf power is transmitted to the beam. At this stage the drive beam needs to be compressed in time in order to increase the peak beam current from 4.2 to 100 A. Three rings are used to this end: the delay loop and two combiner rings. The bunches are interleaved between each other at injection in the different rings by using rf deflectors. This is one of the important novel features of CLIC that finally leads to bunches with repetition frequency of 12 GHz in trains 239 ns long, with a peak current of 100 A. In total, 24 trains follow each other spaced by $5.8 \mu\text{s}$.

The drive beam generation is a critical feasibility point of the CLIC project which is presently being addressed in the CLIC test facility 3 (CTF3) set up as an international collaboration. CTF3 represents a reduced version of the CLIC drive beam complex with a goal intensity of 28 A at 12 GHz, see the layout in Fig. 4. A more comprehensive description and status of CTF3 can be found at [22,23]. Two very important recent achievements have to be mentioned. First, the CTF3 combiner ring has demonstrated the recombination by a factor of 4, increasing the incoming

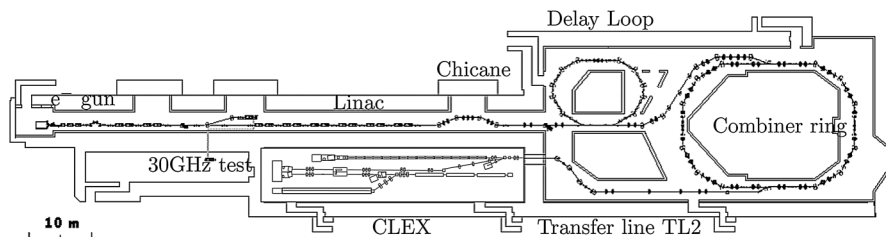

FIG. 4. CTF3 layout.

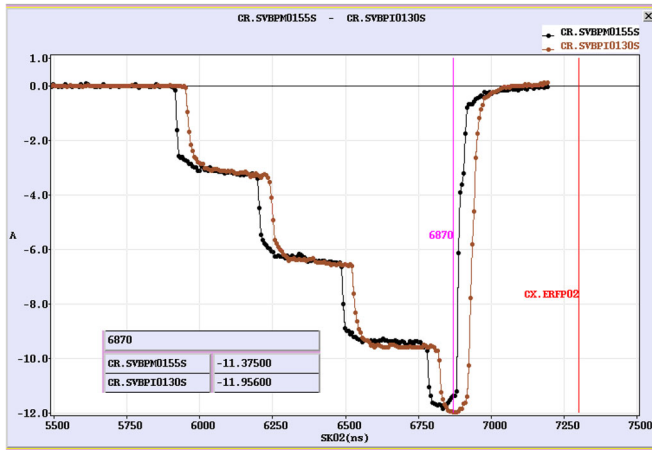

FIG. 5. (Color) Intensity versus time as measured at two different devices of the CTF3 combiner ring, showing the bunch recombination from 3 A beam to 12 A.

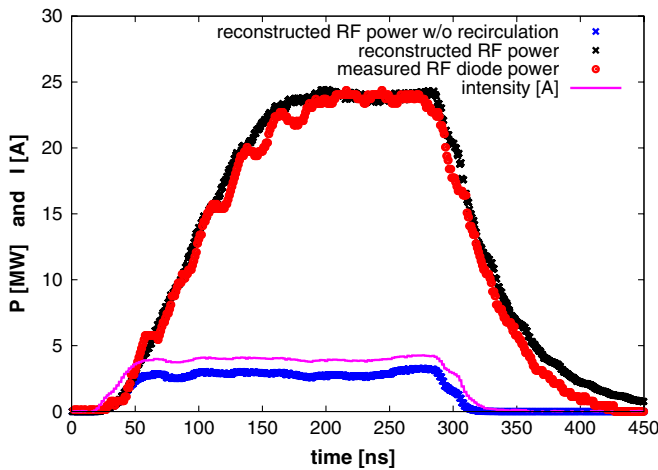

FIG. 6. (Color) PETS measured and reconstructed power.

intensity from 3 to 12 A and the frequency from 1.5 to 6 GHz, see Fig. 5. No significant beam losses were observed. In the future CTF3 should demonstrate a recombination by a factor of 8 by operating both the delay loop and the combiner ring (CR). Beam quality after recombination could be slightly affected due to errors in the rf deflectors or aberrations in the CR transport. Dedicated emittance measurements after recombination will take place in the future.

Second, the CTF3 PETS have demonstrated the power extraction from a low intensity drive beam, see Fig. 6 from Ref. [24]. Moreover, a new technique based on the recirculation of the electromagnetic fields in the PETS has allowed the extraction of about 8 times more power than without the recirculation (red and blue curves in Fig. 6). The good agreement between the model prediction based on a simple model and the measurement as observed in the figure is remarkable. Adopting PETS recirculation for the CLIC baseline design is also being considered.

In parallel the 11.424 GHz scaled version of the CLIC PETS is undergoing high rf power tests in the accelerator structures test area (ASTA) at SLAC [25]. In this experiment PETS are externally driven by klystrons rather than by a beam. Testing PETS in ASTA gives a unique opportunity to understand the limiting factors for the PETS ultimate performance with respect to rf breakdown. At the moment of writing the paper, the PETS had reached 130 MW average power in 266 ns (compared to the CLIC specification of 135 MW and 240 ns). The breakdown rate during few hours operation was 6×10^{-6} per pulse and per meter. The CLIC requirement is 10^{-7} breakdowns per pulse and per meter. High power rf tests continue in order to reach the specified power of 135 MW and measure the breakdown rate. If this is achieved, and in conjunction with the power extraction from beams in CTF3, the feasibility of the CLIC PETS will be demonstrated.

CTF3 was not designed to demonstrate the tight jitter tolerances of the CLIC drive beam rf phase and beam intensity. However, CTF3 serves as a laboratory to test the new feedback technologies that will be used to guarantee the phase and intensity tolerances, see for example [26]. It is planned that future upgrades of CTF3 will focus on the demonstration of the jitter tolerances.

VI. MAIN LINAC

The linac is the 21 km section of the CLIC facility where the drive and the main beams share the tunnel. The PETS decelerate the drive beam in sections of about 800 m and transfer its power to the accelerating structures of the main beam. The main beam is accelerated from 9 GeV to 1.5 TeV. The major challenges of the linac are the demonstration of 100 MV/m accelerating structures with an acceptable breakdown probability and the demonstration of the quadrupole active stabilization down to 1.8 nm [27], for frequencies above 1 Hz.

The fast-ion instability is less of a concern since 10 nTorr is enough to avoid it [28].

Thanks to the collaboration between KEK, SLAC, and CERN, a CLIC-like accelerating structure, named

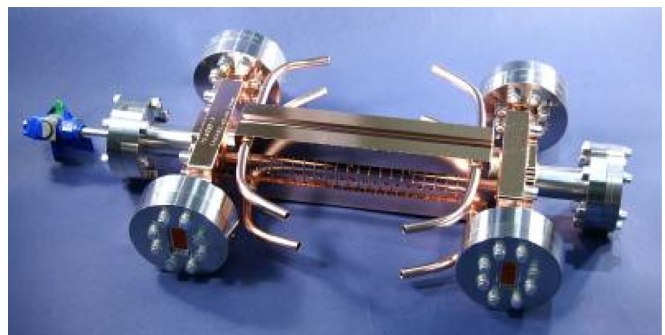

FIG. 7. (Color) Test accelerating cavity for the CLIC main beam, T18_vg2.4_disk, designed at CERN, built at KEK, and assembled and tested at SLAC.

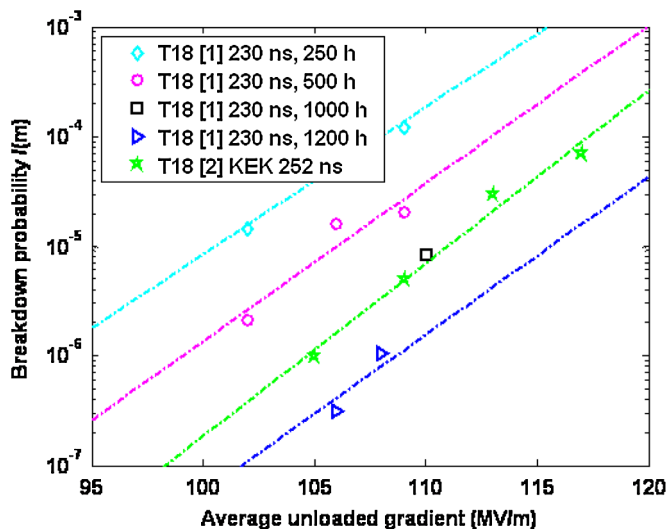

FIG. 8. (Color) Performance of two CLIC-like accelerating structure T18_vg2.4_disk meeting the CLIC specifications during unloaded operation without damping and after about 1200 hours of conditioning. T18[2] was conditioned differently than T18[1]; this might explain the slight difference in breakdown rate. CLIC structures operate loaded and with damping.

T18_vg2.4_disk, has been successfully tested [29]. The CERN design was built in KEK, see Fig. 7, and sent to SLAC for assembly. The rf testing is being performed both in SLAC and KEK with different conditioning procedures. This test structure does not yet incorporate the damping features that CLIC structures need. Two T18_vg2.4_disk cavities demonstrate an unloaded gradient above 100 MV/m with the nominal pulse length and a breakdown probability below 3×10^{-7} per meter, see Fig. 8, corresponding to the CLIC specifications. An important effort is being put in understanding and improving the breakdown processes [30–32].

The time needed for the conditioning of the cavities is above the 1200 hours. This should be taken into account for the CLIC construction schedule, probably conditioning and building in parallel. The full demonstration of a CLIC structure needs to include the damping features. Such a structure is presently under construction [33] and will be tested before the CDR. Previous experience with damping structures [34] suggests that the performance of this new cavity should not be significantly different.

The active stabilization of the linac quadrupoles to a level of 1.8 nm for frequencies above 1 Hz has been already demonstrated in laboratory environments by using ground isolation techniques [35,36]. This cut at 1 Hz divides what has traditionally been considered as slow and fast frequencies [35]. However, the conceptual feedback has changed in the meantime. A review of the quadrupole jitter tolerances is presently ongoing, aiming at specifying the tolerable jitter versus frequency. The challenge remains to apply the laboratory stabilization technology over 21 km

in the real accelerator environment to meet the new jitter specifications.

VII. BEAM DELIVERY SYSTEM

The CLIC beam delivery system (BDS) [37] has to safely guide the 15 MW beams with the strongest possible transverse focusing through the interaction point (IP) and dispose of them in the beam dumps. A collimation system ensures that neither stray particles nor their radiated photons hit the downstream machine or the detector. The first collimator is made of beryllium in order to survive the impact of a full train. The collimator apertures are defined by the aperture bottlenecks downstream, which occur in the final doublet (FD) quadrupoles, right before the IP. The survivability of the first collimator plus the collimation efficiency have been extensively revised by various experts within the CLIC/ILC collaboration [38,39]. The wakefields that the beams experience at the collimators deteriorate the luminosity since it is assumed that the bunch trains come with a transverse jitter of 0.2σ . An optimum solution in terms of collimator and FD apertures is still under investigation [37].

The CLIC final focus system (FFS) is based on the local chromaticity correction scheme presented in [40] with extra nonlinear elements to cancel residual aberrations [41]. The experimental verification of this type of FFS is presently being investigated in the KEK ATF2 facility [42]. ATF2 contains a scaled-down version of the ILC FFS with a vertical IP beam size of about 37 nm. However, the CLIC FFS has about 4 times more chromaticity than ILC or ATF2. An ATF2 R&D proposal has been made [43,44] to reduce the ATF2 IP vertical beta function by a factor of 4. This proposal has a twofold motivation: reduce the IP vertical size as close as possible to ILC and CLIC values, see Table II, and prove the CLIC chromaticity levels.

The ultralow β^* proposal for ATF2 will also serve to investigate the difficulty of tuning the FFS for different IP beam sizes. This might allow extrapolations to the smaller beam sizes of ILC and CLIC. Simulations show that tuning difficulty increases for smaller IP beam sizes [44]. CLIC aims to focus the vertical beam size to about 1 nm, smaller than any other project, see Table II.

TABLE II. Vertical IP beam sizes and vertical chromaticities for different projects. Chromaticity is computed from the elements of the transfer matrices as $(T_{346}R_{33} - T_{336}R_{34})/\sqrt{\beta_y^*}$.

Project	Status	σ_y^* [nm]	ξ_y [10^4]
FFTB	Measured	70	1
ATF2	Commissioning	37	1.9
ATF2 ultralow β	Proposed	20	7.6
ILC	Design	6	1.5
ILC low power	Alternative	4	3
CLIC	Design	1	6.3

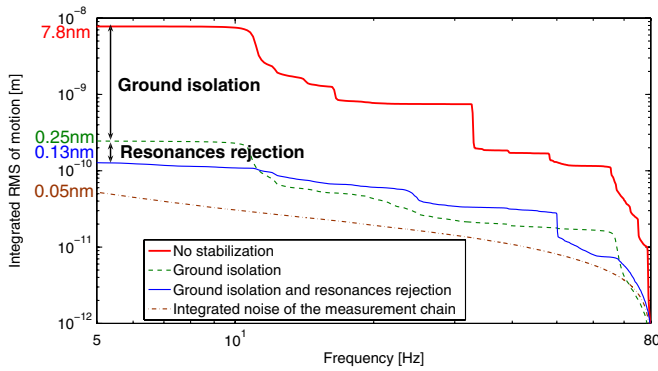

FIG. 9. (Color) Demonstration of stabilization to the subnanometer level via ground isolation and structure resonance rejection in a quiet environment [45].

Because of the nanometric IP beam size, CLIC faces the challenge of the subnanometer stabilization of the last FFS quadrupole (QD0). In order to lose less than 2% luminosity, the vertical jitter of QD0 has to be below 0.15 nm (for frequencies above 4 Hz) with the extra complication that QD0 is embedded in the detector at 3.5 m from the IP. There are very promising experimental results showing stabilization to these levels via active ground isolation and structure resonance rejection techniques in a laboratory environment, see Fig. 9 taken from [45]. The CLIC stabilization working group conducts the research in order to find solutions in the detector environment [46].

A way to considerably ease the stabilization requirement and difficulty would be to move QD0 out of the detector, thus allowing to support it on the ground [47]. This would require increasing L^* to 8 m and a consequent reduction of the design luminosity by 28% [37], therefore it has been suggested to keep the 8 m L^* optics as a fall-back solution.

VIII. MACHINE DETECTOR INTERFACE ISSUES

CLIC presently foresees to have only one interaction region. The “push-pull” concept allows one to host two different detectors in the same cavern, as in the ILC project [48]. The machine detector interface (MDI) is further challenged by the need to embed QD0 and an antisolenoid around it within the detector. All these issues are presently being addressed by the MDI working group [49].

QD0 technical specifications have been pushed to the limit of permanent magnet technology. It features an aperture radius of 3.8 mm with a peak magnetic field of 2.0 T. Its relative gradient jitter should be below 0.05×10^{-4} and the relative octupolar aberration at 1 mm should be below 7×10^{-4} . The feasibility of such a magnet is presently under study [50].

CLIC features a full crossing angle of 20 mrad. Its large geometrical luminosity loss is restored by a crab cavity placed upstream QD0 [51]. Again, due to the nanometric IP spot sizes the tolerances on the rf phase stability of the crab cavity are extremely challenging. In [51] this was

estimated to be 0.02 degrees for the 12 GHz option. The most promising technological option is the NLC design [52], but experimental tests have to be performed in order to assess the feasibility of this tight phase jitter tolerance.

IX. POSTCOLLISION LINE AND BEAM DUMP

Because of the very large number of coherent pairs produced in a 3 TeV collision, the CLIC postcollision line cannot simply be a copy or extension of the ILC design. In ILC a beam energy and a beam polarization measurement station are part of the beam diagnostics after the interaction point. For CLIC, a different approach has been proposed [53]. A set of four vertical bending magnets is used to separate lower energy particles from the beamstrahlung photons and from the main beam. Three sets of collimators are introduced in order to reduce particle losses in the magnets. An intermediate dump is designed to stop all the opposite-sign particles of the coherent pairs as well as the lower energy tail of same-sign particles. After this dump, a second set of vertical bending magnets is used to deflect the remaining beam back onto a horizontal trajectory. Beamstrahlung photons, the core of the beam as well as the remaining particles of energies above 250 GeV, are transported to a common dump. A water dump, similar to the one for ILC, is being studied for CLIC [54].

X. SCHEDULE

The present efforts of the CLIC study focus on the feasibility demonstration for the publication of the conceptual design report (CDR) by the end of 2010 with preliminary estimates of performance and cost. The technical designs, the engineering optimization, and the final cost studies will extend over a five-year period after the CDR leading to the technical design report by the end of 2015. The CLIC proposal would then be ready to seek approval with a construction period of seven years for a 500 GeV facility and another 3.5 years for the upgrade to 3 TeV.

ACKNOWLEDGMENTS

This work is done by the CLIC/CTF3 and CLIC/ILC collaborations: Aarhus University (Denmark), Ankara University (Turkey), Argonne National Laboratory (USA), Athens University (Greece), BINP (Russia), CERN (Switzerland), CIEMAT (Spain), Cockcroft Institute (UK), Gazi Universities (Turkey), Helsinki Institute of Physics (Finland), IAP (Russia), IAP NASU (Ukraine), INFN/LNF (Italy), Instituto de Fisica Corpuscular (Spain), IRFU/Saclay (France), Jefferson Lab (USA), John Adams Institute (UK), JINR (Russia), Karlsruhe University (Germany), KEK (Japan), LAL/Orsay (France), LAPP/ESIA (France), NCP (Pakistan), North-West. University of Illinois (USA), Patras University (Greece), Polytechnique University of

Catalonia (Spain), PSI (Switzerland), RAL (UK), RRCAT/Indore (India), SLAC (USA), Thrace University (Greece), University of Oslo (Norway), and Uppsala University (Sweden). This manuscript contains invaluable contributions from E. Adli, S. Bettoni, H. Braun, O. Brüning, R. Corsini, J-P. Delahaye, S. Doebert, K. Elsener, L. Gatignon, G. Geschonke, A. Grudiev, J-B. Jeanneret, A. Jeremie, Y. Papaphilippou, L. Rinolfi, G. Rumolo, D. Schulte, A. Seryi, H. Schmickler, F. Stulle, and I. Syratchev.

-
- [1] B.B. Barrish and J-P. Delahaye (CLIC-ILC Collaboration), http://clic-study.web.cern.ch/CLIC-Study/CLIC_ILC_Collab_Mtg/Index.htm.
- [2] H. Braun *et al.*, CLIC-Note-764.
- [3] H. Braun *et al.*, *CLIC here for the future*, CERN Courier (IOP Publishing, Bristol, 2008).
- [4] E. Clements, *CLIC—The Compact Linear Collider*, Symmetry Magazine, edited by David Harris (SLAC and FNAL, Batavia, IL, 2005), Vol. 2, Issue 6.
- [5] J. Ellis *et al.*, *Nature (London)* **409**, 431 (2001).
- [6] G. Geschonke, in *Proceedings of the 11th European Particle Accelerator Conference, Genoa, 2008* (EPS-AG, Genoa, Italy, 2008).
- [7] CLIC-CTF3 Collaborations, http://clic-meeting.web.cern.ch/clic-meeting/CTF3_Coordination_Mtg/Table_MoU.htm.
- [8] L. Rinolfi, CLIC-Note 750.
- [9] L. Rinolfi *et al.*, in *Proceedings of Particle Accelerator Conference 09, Vancouver, Canada*, <http://trshare.triumf.ca/~pac09proc/Proceedings/>.
- [10] Y. Papaphilippou *et al.*, CLIC Note 755, 2008.
- [11] S. Casalbuoni *et al.*, in *Proceedings of the 2007 Particle Accelerator Conference, Albuquerque, New Mexico, 2007* (IEEE, Albuquerque, New Mexico, 2007).
- [12] Y. Papaphilippou, H. Braun, and M. Korostelev, in *Proceedings of the 11th European Particle Accelerator Conference, Genoa, 2008* (Ref. [6]).
- [13] G. Rumolo *et al.*, in *Proceedings of the 11th European Particle Accelerator Conference, Genoa, 2008* (Ref. [6]).
- [14] G. Rumolo, W. Bruns, and Y. Papaphilippou, in *Proceedings of the 11th European Particle Accelerator Conference, Genoa, 2008* (Ref. [6]).
- [15] Y. Papaphilippou, CLIC meeting, April 3, 2009: <http://indico.cern.ch/conferenceDisplay.py?confId=55080>.
- [16] SPS upgrade study team: <http://paf-spsu.web.cern.ch/paf-spsu/>.
- [17] S. Cataloni and G. Rumolo, “e-cloud measurements at CESR-TA”, CLIC Meeting, October 2, 2009; <http://indico.cern.ch/conferenceDisplay.py?confId=69028>.
- [18] F. Stulle *et al.*, EuroTev Reports No. 2008-86 and No. 2008-25.
- [19] J. B. Jeanneret *et al.*, in *Proceedings of the 11th European Particle Accelerator Conference, Genoa, 2008* (Ref. [6]).
- [20] F. Stulle *et al.*, in *Proceedings of Particle Accelerator Conference 09, Vancouver, Canada* (Ref. [9]).
- [21] G. Rumolo *et al.*, in *Proceedings of the 11th European Particle Accelerator Conference, Genoa, 2008* (Ref. [6]).
- [22] R. Corsini, in *Proceedings of Particle Accelerator Conference 09, Vancouver, Canada* (Ref. [9]).
- [23] S. Bettoni, in *Proceedings of Particle Accelerator Conference 09, Vancouver, Canada* (Ref. [9]).
- [24] E. Adli, CERN Report No. CTF3-Note-096, 2009.
- [25] I. Syratchev *et al.*, in *Proceedings of Particle Accelerator Conference 09, Vancouver, Canada* (Ref. [9]).
- [26] A. Andersson and J.P.H. Sladen, CERN-AB-2008-003 (RF) and CLIC-Note-734.
- [27] D. Schulte *et al.*, in *Proceedings of Particle Accelerator Conference 09, Vancouver, Canada* (Ref. [9]).
- [28] G. Rumolo *et al.*, in *Proceedings of Particle Accelerator Conference 09, Vancouver, Canada* (Ref. [9]).
- [29] S. Döbert *et al.*, LINAC08, XXIV Linear Accelerator Conference, Victoria, Canada, <http://trshare.triumf.ca/~linac08proc/Proceedings/LINAC08/>.
- [30] A. Descoedres, S. Calatroni, and M. Taborelli, in *Proceedings of the 11th European Particle Accelerator Conference, Genoa, 2008* (Ref. [6]).
- [31] M. Johnson, T. Ekelof, R. Ruber, and V. Ziemann, in *Proceedings of the 11th European Particle Accelerator Conference, Genoa, 2008* (Ref. [6]).
- [32] J. Kovermann, in the Robert Siemann Symposium and ICFA Mini-Workshop, SLAC, 2009.
- [33] A. Grudiev, in the Robert Siemann Symposium and ICFA Mini-Workshop, SLAC, 2009.
- [34] I. Wilson, W. Wuensch, C. Achard, M. Dehler, E. Jensen, M. Luong, C. Adolphsen, M. Ross, T. Slaton, and D. McCormick, in *Proceedings of the 7th European Particle Accelerator Conference, Vienna, 2000*, <http://accelconf.web.cern.ch/AccelConf/e00/index.html>.
- [35] S. Redaelli, CERN Reports No. CERN-AB-2004-026-ABP and No. CERN-CLIC-NOTE-595 2004.
- [36] L. Brunetti *et al.*, Report No. EUROTeV-Report-2008-006.
- [37] R. Tomás *et al.*, in *Proceedings of Particle Accelerator Conference 09, Vancouver, Canada* (Ref. [9]).
- [38] J. Resta López, in the CLIC08 Workshop, 2008, CERN.
- [39] CERN-CI and CLIC/ILC collimation meeting, <http://ilcagenda.linearcollider.org/conferenceDisplay.py?confId=3515>.
- [40] P. Raimondi and A. Seryi, *Phys. Rev. Lett.* **86**, 3779 (2001).
- [41] R. Tomás, Report No. CERN-OPEN-2006-023; *Phys. Rev. ST Accel. Beams* **9**, 081001 (2006).
- [42] “ATF2 Proposal,” KEK Report 2005-2, SLAC-R-796, CERN-AB-2006-004, DESY 06-001, JAI-2006-001 and ILC-Asia-2005-26.
- [43] D. Angal-Kalinin *et al.*, CARE/ELAN Document-2008-002.
- [44] D. Angal-Kalinin *et al.*, in *Proceedings of Particle Accelerator Conference 09, Vancouver, Canada* (Ref. [9]).
- [45] B. Bolzon *et al.*, in the Nanobeam Workshop 2008 and LAPP laboratory note: LAPP-TECH-2008-05.
- [46] 5th meeting of the CLIC Stabilization working group, March 2009, Anney; <http://indico.cern.ch/conferenceDisplay.py?confId=54934>.
- [47] A. Seryi, in the CLIC08 Workshop, 2008, CERN.
- [48] B. Barish, “The Evolving ILC Design: Push-Pull Detector Arrangement”, Director’s Corner: <http://www.linearcollider.org/cms/?pid=1000373>.
- [49] MDI working group; <http://indico.cern.ch/>

- categoryDisplay.py?categId=2003.
- [50] D. Swoboda, in the 4th MDI working group meeting, February 2009, <http://indico.cern.ch/conferenceDisplay.py?confId=52607>.
- [51] A. Dexter, in the CLIC08 workshop, 2008, CERN.
- [52] J. Frisch, Report No. SLAC-TN-04-004, 2004.
- [53] A. Ferrari, Volker Ziemann, B. Appleby, and M.D. Salt, Phys. Rev. ST Accel. Beams **12**, 021001 (2009).
- [54] S. Polepalle and R. Arnold, in the CLIC08 Workshop, 2008, CERN.