

Hanbury Brown–Twiss Correlations to Probe the Population Statistics of GHz Photons Emitted by Conductors

J. Gabelli,¹ L.-H. Reydellet,² G. Fève,¹ J.-M. Berroir,¹ B. Plaçais,¹ P. Roche,² and D. C. Glattli^{1,2,*}

¹Laboratoire Pierre Aigrain, Département de Physique de l'École Normale Supérieure, 24 rue Lhomond, 75231 Paris Cedex 05, France

²Service de Physique de l'Etat Condensé, CEA Saclay, F-91191 Gif-sur-Yvette, France

(Received 23 March 2004; published 27 July 2004)

We present the first study of the statistics of GHz photons in quantum circuits, using Hanbury Brown and Twiss correlations. The super-Poissonian and Poissonian photon statistics of thermal and coherent sources, respectively, made of a resistor and a radio frequency generator, are measured down to the quantum regime at milli-Kelvin temperatures. As photon correlations are linked to the second and fourth moments of current fluctuations, this experiment, which is based on current cryogenic electronics, may become a standard for probing electron/photon statistics in quantum conductors.

DOI: 10.1103/PhysRevLett.93.056801

PACS numbers: 73.23.-b, 42.50.Ar, 73.50.Td

The seminal experiment of Hanbury Brown and Twiss (HBT) [1], consisted in two detectors correlating the power fluctuations of a single electromagnetic source at the outputs of a beam splitter [Fig. 1(a)]. Positive correlations observed for thermal photons within the coherence time have been interpreted as originating from photon bunching due to Bose-Einstein statistics [2]. Since correlations are very sensitive to statistics, HBT experiments have been widely used to investigate optical sources: laser light has Poissonian fluctuations revealed by vanishing HBT correlations; negative correlations have also been reported for nonclassical sources [3].

HBT correlations have also been observed with degenerate electrons in quantum conductors, where the analogue of the photon flux is the electrical current. Because of Fermi statistics, electrons emitted by contacts can be noiseless. As a result, sub-Poissonian noise and electron antibunching are observed [4–7], in quantitative agreement with predictions [8–11]. Comparing photon and electron statistics would remain a formal exercise unless one notices the dual representation of the current as fermionic excitations in a quantum conductor and bosonic electromagnetic modes in the external measuring circuit. This raises the intriguing question of how to relate the sub-Poissonian statistics of electrons fluctuations in the conductor to the statistics of the emitted photons [12–14]. A first theoretical answer has been given in Ref. [15] where the photon statistics is shown to remarkably deviate from the super-Poissonian black-body radiation. As shown below there is also a direct relation between photon statistics and the fourth moment of the electron full counting statistics [14].

But how to measure reliably the photon statistics in quantum circuits? Quantum effects in conductors, best displayed at sub-Kelvin temperatures, require few photon number detection at GHz frequencies and make experimental detection of TEM photon fluctuations challenging. An elegant approach is provided by quantum dots and

superconducting mesoscopic photon detectors [16,17]. However, a more versatile approach is to use cryogenic low noise amplifiers (LNA) followed by detectors.

In this Letter, we present the first HBT photon correlation measurements in the GHz range and in the few photon population number regime. The use of linear phase-insensitive amplification prior to photon detection provides a new situation having no optical counterpart. It is shown to preserve the nature of the HBT correlations characterizing the photon source under test. The sensitivity to various statistics is tested. First, an impedance matched resistor is used which provides an ideal black-body thermal source. Although expected, we show for the

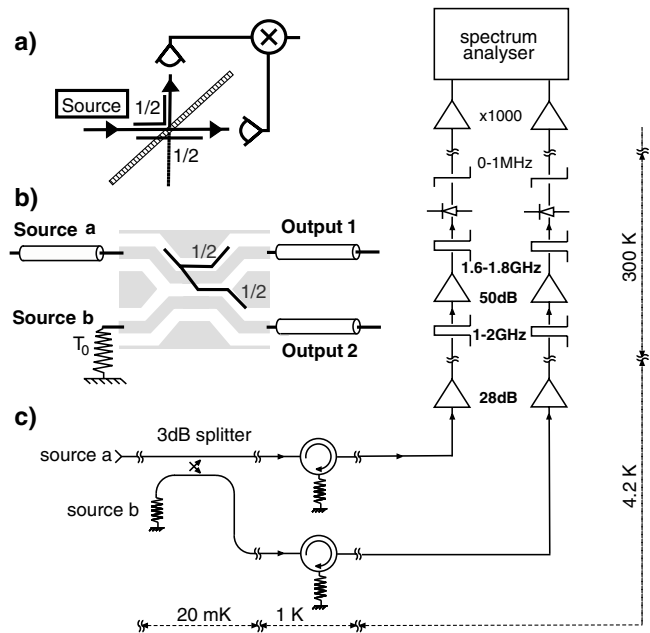

FIG. 1. Schematics of the HBT experiment (a), of the GHz beam splitter (b), of the amplification and detection chains (c). A detailed description is given in the text.

first time that the Johnson-Nyquist noise is associated with super-Poissonian noise and positive HBT correlations characteristic of Bose-Einstein thermal distribution. Second, a low noise radio frequency generator is used as a monochromatic coherent photon source. It is found to generate coherent photons with Poissonian statistics and vanishing HBT correlations (like a Laser). Regarding autocorrelations, which are sensitive to detection details, a quantum description of the amplifier noise is made which quantitatively agrees with our measurements.

Following Nyquist [18], the current noise power of a conductor of conductance G can be related to the power of TEM waves emitted in the external circuit. If Z is the characteristic circuit impedance, the average power in a small frequency range ν , $\nu + d\nu$ is

$$\bar{P} = \frac{Z}{(1 + GZ)^2} S_I(\nu) d\nu = \bar{N} h\nu d\nu.$$

Here N is the photon population, and $S_I(\nu) = \overline{(\Delta I)^2}/d\nu$ the spectral density of current fluctuation $\Delta I(t)$ filtered in the frequency range ν , $\nu + d\nu$ [19]. The fluctuations of the current noise power entail fluctuations in the photon power at frequencies much lower than ν . For classical currents, its variance, proportional to the low frequency bandwidth B , is, according to notations in [19],

$$\langle(\Delta P)^2\rangle = \frac{Z^2}{(1 + GZ)^4} \langle[(\Delta I)^2(t) - \overline{(\Delta I)^2}]^2\rangle$$

and that of the photon population is directly related to the fourth moment of the current fluctuation:

$$\overline{(\Delta N)^2} = \left(\frac{Ze^2}{h(1 + GZ)^2}\right)^2 \times \frac{\overline{(\Delta I)^4} - [\overline{(\Delta I)^2}]^2}{(e^2\nu d\nu)^2}.$$

According to Glauber [20], thermal fluctuations of a *classical* current lead to super-Poissonian fluctuations $\overline{(\Delta N)^2} = \bar{N}(1 + \bar{N})$ or

$$\langle(\Delta P)^2\rangle = 2B\bar{N}(1 + \bar{N})(h\nu)^2 d\nu, \quad (1)$$

with \bar{N} given by the Bose-Einstein distribution. In the case of quantum conductors, the current is no longer a classical observable and the unsymmetrized current noise operator $\hat{S}_I(\nu, t) = \int_{-\infty}^{+\infty} d\tau \hat{I}(t)\hat{I}(t + \tau) \exp(i2\pi\nu\tau)$ is needed [16,21]. A full quantum treatment can be found in Ref. [15] which shows that, for conductors with large numbers of electronic modes, the statistics of photons shows only small deviations from Bose-Einstein distribution even when shot noise dominates over thermal noise. However, a single electronic mode conductor with transmission close to 1/2 is found to emit nonclassical photons for frequency in the range I/e . Nonclassical photons are characterized by negative deviations $\overline{(\Delta N)^2} - \bar{N}$ from the Poisson statistics, which is precisely the quantity that HBT correlations measure. This remarkable result and the connection with the fourth moment of

the full electron current statistics provide a strong motivation to investigate HBT photon correlations in quantum circuits.

The radio-frequency equivalent of the optical HBT experiment is shown in Fig. 1(b). Source (a) is the rf-photon source under test. The emitted TEM photons propagate through a short 50 Ω characteristic impedance coaxial line and are fed to a cryogenic 3 dB stripline power splitter. The splitter scattering matrix, measured with a network analyzer, is identical to that of an optical separatrix (phases included). A built-in 50 Ω resistor, source (b), plays the role of the vacuum channel of the optical case. Photon vacuum is achieved when its temperature T_0 satisfies $T_0 \ll T_Q$ where $T_Q = h\nu/k_B$. Outputs (1) and (2) of the power splitter are not immediately detected but a 1–2 GHz linear phase-insensitive amplification chain is inserted before square-law detection [see Fig. 1(c)]. Each chain consists in a microwave circulator followed by an ultralow noise cryogenic amplifier and room temperature amplifiers. The circulators, at low temperature, ensure that amplifiers do not send back photons towards (a) and (b). The detectors give an output voltage proportional to the photon intensity after amplification $P_{1,2}^{\text{out}}$. Their finite 1 μ s integration time allows to monitor the low frequency photon intensity fluctuations. A fast numerical spectrum analyzer calculates the autocorrelations $\langle(\Delta P_{1,2}^{\text{out}})^2\rangle$ and the HBT cross correlations $\langle\Delta P_1^{\text{out}}\Delta P_2^{\text{out}}\rangle$ in the band 40–200 kHz ($B = 160$ kHz).

In a first series of experiments, A and B , the sensitivity to Bose-Einstein statistics is tested. In a third experiment C , Poisson's statistics is tested using coherent photons. In A , source (a) is a 50 conductor whose temperature T is varied from 20 mK to several K, while source (b) realizes good photon vacuum ($T_0 = 17$ –20 mK $< T_Q$). A pair of 1.64–1.81 GHz filters select a narrow band frequency around $\nu = 1.72$ GHz, with $T_Q = 86$ mK and $h\nu \ll k_B T$. A quantum description of the amplifiers (see below) predicts the mean powers $P_i = P_i^{\text{out}}/G_i$, referred to the input, and their fluctuations:

$$\bar{P}_i = \left(\frac{\bar{N}_a}{2} + \frac{\bar{N}_b}{2} + \frac{k_B T_{N,i}}{h\nu}\right) h\nu d\nu, \quad i = 1, 2, \quad (2)$$

$$\begin{aligned} \langle(\Delta P_i)^2\rangle &= 2B \left(\frac{\bar{N}_a}{2} + \frac{\bar{N}_b}{2} + \frac{k_B T_{N,i}}{h\nu}\right) \\ &\times \left(\frac{1}{G_i} + \frac{\bar{N}_a}{2} + \frac{\bar{N}_b}{2} + \frac{k_B T_{N,i}}{h\nu}\right) (h\nu)^2 d\nu \\ &\approx \langle P_i \rangle^2 \frac{2B}{d\nu}, \end{aligned} \quad (3)$$

$$\langle\Delta P_1 \Delta P_2\rangle = 2B \left(\frac{\bar{N}_a}{2} - \frac{\bar{N}_b}{2}\right)^2 (h\nu)^2 d\nu. \quad (4)$$

Here \bar{N}_a and \bar{N}_b are the photon populations of sources (a)

and (b) given by Bose-Einstein distribution, with $\bar{N}_b \approx 0$ as $T_0 \ll T_Q$. Autocorrelations differ from Eq. (1) in two ways: first, the factor 1 in the second parenthesis, revealing the independent particle behavior of thermal photons is replaced by $1/G_i$ ($G_i = 80$ dB) when referred to the amplifier input; second, an extra photon population is added due to amplifier noise expressed in temperature units $T_{N,i}$ ($T_N \approx 15$ K in the experiment A and $T_N \approx 6$ K in experiments B and C). The HBT cross correlation is unaffected by amplification.

Experimental results are shown in Fig. 2. The solid line is the Bose-Einstein theoretical fit of the mean photon power with Eq. (2) taking T_N and G as free parameters. The experimental data reproduce well the quantum crossover at $T_Q/2 \approx 43$ mK. This is the coldest quantum crossover ever reported for microwave photons. The parameter G is consistent with independent setup calibration. The experimental scatter, $\delta T \approx 1$ mK in temperature units, corresponds to the resolution $\delta T \approx 2T_N/\sqrt{d\nu\Delta t}$ expected for few seconds acquisition time Δt . This unprecedented sensitivity amounts to flux rate variations of 1 photon per μs . The HBT cross correlations $\langle \Delta P_1 \Delta P_2 \rangle$ are expected to vary like $(\bar{N}_a)^2 \approx (T/T_Q)^2$ for $T > T_Q$ as $\bar{N}_B = 0$. This is exactly what we observed in Fig. 2. This provides the first evidence for Bose-Einstein correlations of photon emitted by a resistor in the few photon number limit at sub-Kelvin temperature. The correlation resolution is $\delta\langle(\Delta P)^2\rangle \approx \langle(\Delta P_{1,2})^2\rangle/\sqrt{B\Delta t}$. This corresponds to detect

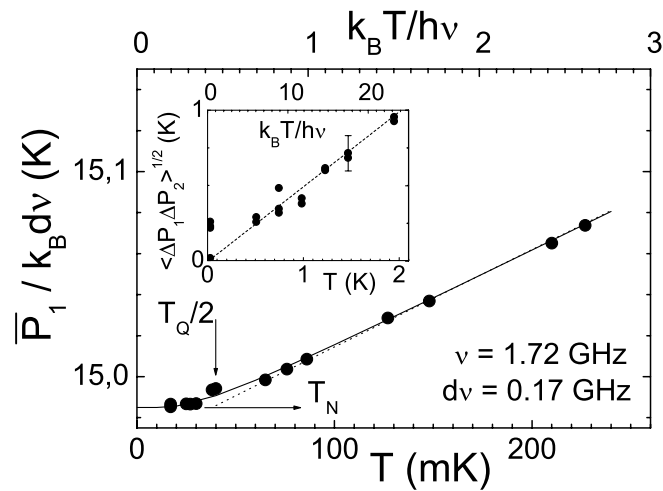

FIG. 2. Experiment A: Thermal source at $\nu = 1.7$ GHz. Main frame: quantum crossover at $T_Q/2 \approx 40$ mK in the mean photon power \bar{P}_1 as function of temperature T , or effective occupation number $k_B T/h\nu$ for a beam splitter temperature $T_0 \approx 17$ mK. The solid line is a Bose-Einstein fit with an amplifier noise temperature $T_N \approx 15$ K. Inset: positive HBT correlations show the bunching of thermal photons and the absence of residual correlations at $T = 0$ K. Experimental scatter lies within the expected statistical uncertainty (error bar).

population fluctuations of $\sqrt{\Delta N_1 \Delta N_2} \approx k_B T_N / (h\nu\sqrt{B\Delta t}) \approx 1.5$ for our experimental $\Delta t = 1000$ s.

Experiment B provides evidence for vanishing HBT correlations $\langle \Delta P_1 \Delta P_2 \rangle \approx (\bar{N}_a - \bar{N}_b)^2$ when $\bar{N}_a = \bar{N}_b$. The experiment is performed at higher temperature ($T = 4-24$ K, $T_0 = 4$ K). Source (b) is no longer in the ground state: $\bar{N}_b(\nu) \approx k_B T_0/h\nu \approx 40$. Here, the central frequency is $\nu = 1.5$ GHz, the bandwidth $d\nu \approx 0.8$ GHz, and the amplifier noise temperatures $T_{N,i} = 6$ K and 8 K. As shown in Fig. 3, $\bar{P}_{1,2}$ linearly depend on temperature in agreement with Eq. (2). The $T = 0$ extrapolates define the LNA noise temperatures. In our analysis the linear slopes give $G_1 = 1.53 \times 10^8$ ($\Delta\nu_1 = 0.75$ GHz), $G_2 = 1.17 \times 10^8$ ($\Delta\nu_2 = 0.88$ GHz) in fair agreement (within 20%) with independent calibration. The square root of the autocorrelation shows linear variation with temperature exemplifying the super-Poissonian noise of thermal photons given by Eq. (3). There are no free parameter left for the HBT correlations as gains are known. They are found positive and quantitatively agree with Eq. (4) (solid line in Fig. 3). They extrapolate to 0 for equal temperature sources [22].

Experiment C tests the sensitivity to a different statistics. A microwave source of frequency $\nu_0 = 1.5$ GHz and bandwidth ≈ 100 Hz generates monochromatic photons. Its output is attenuated at cryogenic temperature T_{att} . The average power \bar{P}_a in (a), is chosen comparable to that delivered by the thermal source in experiment B. As for a laser, the source is expected to generate coherent photon

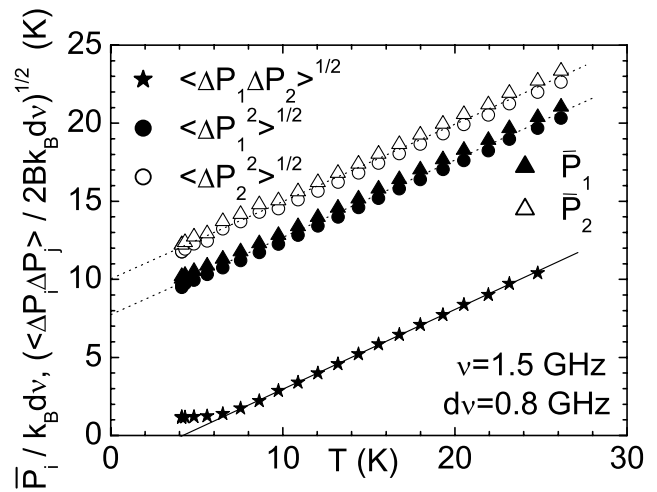

FIG. 3. Experiment B: Super-Poissonian correlations of a thermal source in the classical regime: mean photon power \bar{P}_i and noise $\sqrt{\langle \Delta P_i \Delta P_j \rangle}$ (bandwidth $B = 160$ kHz) as a function source temperature T with a beam splitter at $T_0 \approx 4$ K. The temperature scale of $\sqrt{\langle(\Delta P_i)^2\rangle}$ and \bar{P}_i is used as a calibration of the measuring line. Cross correlations $\sqrt{\langle \Delta P_1 \Delta P_2 \rangle}$ are deduced without extra parameter and found to extrapolate to 0 for $T = T_0$, in agreement with Eq. (4).

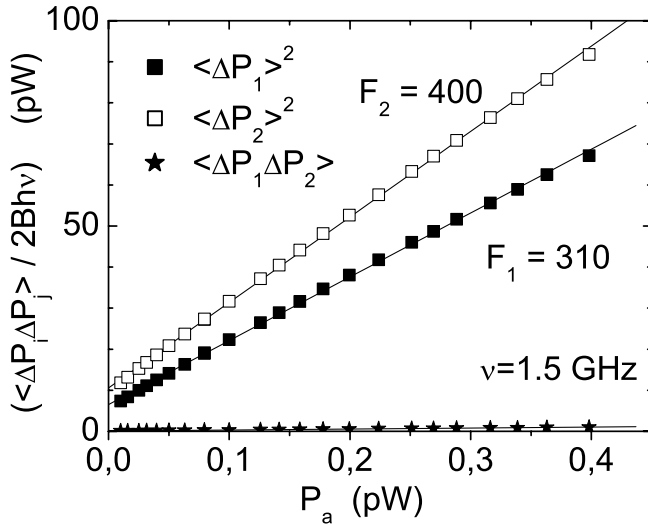

FIG. 4. Experiment C: Poissonian correlations of a coherent monochromatic source. Autocorrelations are linear in the input RF power with a large Fano factor F due to amplification and attenuation. Cross correlations vanish in accordance with theoretical predictions.

states [20]. The photon statistics being Poissonian, the low frequency power fluctuations of source (a) in bandwidth B are $\langle (\Delta P_a)^2 \rangle = 2Bh\nu_0 \bar{P}_a$. An important question is whether attenuation and amplification before detection change the statistics and if yes how. According to Refs. [23,24], the commutation rules for bosonic input and output operators imply the addition of an extra bosonic operator describing the amplifier/attenuator noise. Applying this quantum constraint, we find (in units referred to the amplifier chain input):

$$\begin{aligned} \langle (\Delta P_{1,2})^2 \rangle &= 2Bh\nu_0 F_{1,2} \bar{P}_{1,2}, & \langle \Delta P_1 \Delta P_2 \rangle &= 0, \\ F_{1,2} &= 1 + 2k_B \frac{T_{\text{att}} + T_{N1,2}}{h\nu_0}, \end{aligned}$$

where we have used $T_{\text{att}} = T_0$. Again, amplification has no effect on HBT cross correlations and the absence of cross correlation characterizing Poisson's statistics remains. In the autocorrelations, a Fano factor F appears due to amplification noise. The results of experiment C are shown in Fig. 4. Cross- and autocorrelations are plotted versus detected power referred to the input. Cross correlations are negligible at the scale of the autocorrelations [22]. Autocorrelations are perfectly linear with power as expected. We measure a large Fano factor $F_{1,2} = 310, 400$ in accordance with the order of magnitude of $(T_{\text{att}} + T_{N1,2})/h\nu_0$.

In conclusion, the highly sensitive HBT photon correlations performed in the GHz range at sub-Kelvin temperature using phase insensitive LNA and square-law detection easily discriminate between different statistics. In particular, the cross correlations are unaffected by amplification details. The method, simple, versatile and

based on currently available electronics, can be easily reproduced in other laboratories. It appears to be very suitable to study the photon population statistics of TEM modes emitted by quantum conductors or equivalently the fourth moment of current fluctuations.

We thank J.-D. Gallego and A. Barcia from Centro Astronomico Nacional di Yebes and B. Lazareff and J. Y. Chenu from IRAM for providing us with cryogenic amplifiers. This research has been supported by the S.E.S.A.M.E. program E.1436 of the Ile de France Region. The laboratoire Pierre Aigrain is "unité mixte de recherche" (UMR 8551) of the Ecole Normale Supérieure, the CNRS, and the Universities Paris 6 and Paris 7.

*Electronic address: glattli@lpa.ens.fr

- [1] R. Hanbury Brown and R. Q. Twiss, *Nature* (London) **177**, 27 (1956).
- [2] E. M. Purcell, *Nature* (London) **178**, 1448 (1956).
- [3] P. Grangier, G. Roger, and A. Aspect, *Europhys. Lett.* **1**, 173 (1986).
- [4] M. Reznikov, M. Heiblum, H. Shtrikman, and D. Mahalu, *Phys. Rev. Lett.* **75**, 3340 (1995).
- [5] A. Kumar, L. Saminadayar, D. C. Glattli, Y. Jin, and B. Etienne, *Phys. Rev. Lett.* **76**, 2778 (1996).
- [6] M. Henny, S. Oberholzer, C. Strunk, T. Heinzel, M. Holland, and C. Schönenberger, *Science* **284**, 296 (1999).
- [7] W. D. Oliver, K. Kim, R. C. Liu, and Y. Yamamoto, *Science* **284**, 299 (1999).
- [8] Y. M. Blanter and M. Buttiker, *Phys. Rep.* **336**, 2 (2000).
- [9] G. B. Lesovik, *JETP Lett.* **49**, 592 (1989).
- [10] M. Büttiker, *Phys. Rev. Lett.* **65**, 2901 (1990).
- [11] T. Martin and R. Landauer, *Phys. Rev. B* **45**, 1742 (1992).
- [12] B. Yürke and J. S. Denker, *Phys. Rev. A* **29**, 1419 (1984).
- [13] L. S. Levitov and G. B. Lesovik, *JETP Lett.* **58**, 230 (1993).
- [14] M. Kindermann and Y. V. Nazarov, cond-mat/0303590.
- [15] C. W. J. Beenakker and H. Schomerus, *Phys. Rev. Lett.* **86**, 700 (2001).
- [16] R. Aguado and L. P. Kouwenhoven, *Phys. Rev. Lett.* **84**, 1986 (2000).
- [17] R. Deblock, E. Onac, E. Gurevich, and L. P. Kouwenhoven, *Science* **301**, 203 (2003).
- [18] H. Nyquist, *Phys. Rev.* **32**, 110 (1928).
- [19] Throughout this Letter, $\bar{\chi}$ denotes the mean value of χ over the full bandwidth ($d\nu/2$) whereas $\langle \chi \rangle$ denotes the estimate of $\bar{\chi}$ in the truncated measurement bandwidth B
- [20] R. J. Glauber, *Phys. Rev.* **131**, 2766 (1963).
- [21] U. Gavish, Y. Levinson, and Y. Imry, *Phys. Rev. B* **62**, 10637(R) (2000).
- [22] Residual cross-correlations are due to small splitter imperfections combined with temperature of the circulators, which is 4 K in experiments *B* and *C*.
- [23] C. M. Caves, *Phys. Rev. D* **26**, 1817 (1982).
- [24] Y. Yamamoto and H. A. Haus, *Rev. Mod. Phys.* **58**, 1001 (1986).