

Continuous Variable Entanglement using Cold Atoms

V. Josse, A. Dantan, A. Bramati, M. Pinard, and E. Giacobino

Laboratoire Kastler Brossel, Université Pierre et Marie Curie, Case 74, 4 place Jussieu, 75252 Paris CEDEX 05, France

(Received 10 September 2003; published 22 March 2004)

We present an experimental demonstration of both *quadrature* and *polarization entanglement* generated via the interaction between a coherent linearly polarized field and cold atoms in a high finesse optical cavity. The nonlinear atom-field interaction produces two squeezed modes with orthogonal polarizations which are used to generate a pair of nonseparable beams, the entanglement of which is demonstrated by checking the inseparability criterion for continuous variables recently derived by Duan *et al.* [Phys. Rev. Lett. **84**, 2722 (2000)] and calculating the *entanglement of formation* [Giedke *et al.*, Phys. Rev. Lett. **91**, 107901 (2003)].

DOI: 10.1103/PhysRevLett.92.123601

PACS numbers: 42.50.Dv, 03.67.Mn, 42.50.Ct

Entanglement in the continuous variable regime has attracted a lot of attention in the quantum optics and quantum information fields in connection with quantum teleportation, cryptography, quantum computing, and dense coding [1]. Since the first realization of quadrature entangled beams by Ou *et al.* [2], various methods, such as the $\chi^{(2)}$ process in optical parametric amplifier (OPA) [3] or the Kerr effect in optical fibers [4], have been used to generate nonseparable beams. Recently, the concept of *polarization entanglement*, i.e., entanglement of Stokes operators between two beams, has been investigated by Korolkova *et al.* [5], and first demonstrated experimentally by Bowen *et al.* [6] by mixing two squeezed beams issued from independent OPAs. The Kerr nonlinearity of fibers was also exploited by Glöckl *et al.* to generate a pulsed source of polarization entanglement [7].

In this Letter, we show evidence for continuous variable entanglement generated using the interaction between a linearly polarized coherent field and a cloud of cold cesium atoms placed in a high finesse optical cavity. We demonstrate the entanglement using the inseparability criterion proposed by Duan *et al.* and Simon [8]. We generate two kinds of entanglement with the same system, quadrature entanglement and polarization entanglement. For this, we use the recently reported generation of polarization squeezing [9] in the field that has interacted with cold atoms; both the mean field mode and the vacuum mode with orthogonal polarization exiting the cavity can be squeezed. First, we show how a direct measurement of the quadrature entanglement of the beam exiting the cavity can be achieved using two balanced homodyne detections. We then give the form of the covariance matrix and the associated *entanglement of formation* (EOF), which, for Gaussian symmetric states, is directly related to the inseparability criterion value [10]. Last, we produce two nonseparable beams by mixing two parts of the previous outgoing beam with a strong field and achieve polarization entanglement by locking the relative phases between the strong field and the weak field exiting the cavity.

First, let us consider two orthogonally polarized modes A_a and A_b of the electromagnetic field satisfying the usual bosonic commutation rules $[A_\alpha, A_\beta^\dagger] = \delta_{\alpha\beta}$. If $X_\alpha(\theta) = (A_\alpha^\dagger e^{i\theta} + A_\alpha e^{-i\theta})$ and $Y_\alpha(\theta) = X_\alpha(\theta + \pi/2)$ are the usual quadrature operators (rotated in the Fresnel diagram by angle θ), $X_a + X_b$ and $Y_a - Y_b$ are the continuous variable analogous of the EPR-type operators first introduced by Einstein, Podolsky, and Rosen [11]. The criterion of [8] sets a limit for inseparability on the sum of the operator variances

$$J_{a,b}(\theta) = \frac{1}{2}[\Delta^2(X_a + X_b)(\theta) + \Delta^2(Y_a - Y_b)(\theta)] < 2. \quad (1)$$

For states with Gaussian statistics, $J_{a,b} < 2$ is a sufficient condition for entanglement and has already been used in several experiments to demonstrate continuous variable entanglement [5–7]. Moreover, Giedke *et al.* recently calculated the EOF of Gaussian symmetric states [10] and showed it to be directly related to the amount of EPR-type correlations given by (1).

In our system, an x -polarized beam interacts with a cloud of cold cesium atoms in an optical cavity. The experimental setup [9] is shown in Fig. 1. We probe the atoms with a linearly polarized laser beam detuned by about 50 MHz in the red of the $6S_{1/2}, F = 4$ to $6P_{3/2}, F = 5$ transition. The optical power of the probe beam ranges from 5 to 15 μ W. After exiting the cavity, both the mean field mode A_x and the orthogonally polarized vacuum mode A_y are squeezed for frequencies ranging between 3 and 12 MHz. An interpretation of these results can be provided by modeling the complicated $6S_{1/2}, F = 4$ to $6P_{3/2}, F = 5$ transition by an X-like four-level atomic structure [12]. When the optical transitions are saturated, the atoms behave as a Kerr-like medium for the mean field mode A_x , which can be squeezed. Furthermore, the orthogonally polarized vacuum mode A_y is also squeezed on account of cross-Kerr effect, but for an *orthogonal* quadrature [9,12].

Our goal is to retrieve the two modes with orthogonal polarizations which exhibit maximal EPR-type correlations according to the inseparability criterion (1). We

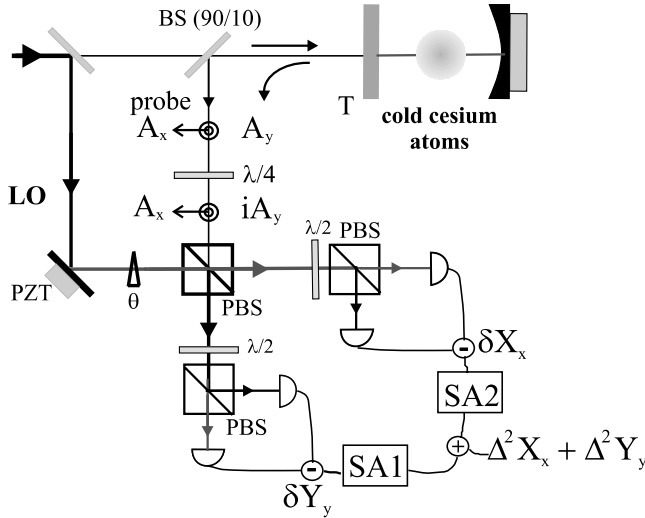

FIG. 1. Experimental setup: PBS, polarizing beam splitter; $\lambda/2$, half-wave plate; PZT, piezoelectric ceramic; SA, spectrum analyzer. $T = 0.1$ is the transmission of the cavity coupling mirror.

therefore minimize the quantity $I_{a,b}(\theta)$ with respect to a, b and θ . Expanding (1) yields

$$I_{a,b}(\theta) = \langle \delta A_a^\dagger \delta A_a + \delta A_a \delta A_a^\dagger + \delta A_b \delta A_b^\dagger + \delta A_b^\dagger \delta A_b \rangle + 2[e^{-2i\theta} \langle \delta A_a \delta A_b \rangle + e^{2i\theta} \langle \delta A_a^\dagger \delta A_b^\dagger \rangle]. \quad (2)$$

The right-hand side of the first line in (2) is independent of the polarization basis, while the second line can be written as $4 \cos(2\theta - 2\phi) |\langle \delta A_a \delta A_b \rangle|$, where 2ϕ is the phase angle of $\langle \delta A_a \delta A_b \rangle$. Minimizing $I_{a,b}(\theta)$ corresponds to maximizing $|\langle \delta A_a \delta A_b \rangle|$ with respect to a, b . In order to find the optimal field components a, b , we introduce another polarization basis u, v , such that $\langle \delta A_u \delta A_v \rangle = 0$. It can be shown that there always exists such a polarization basis and that the u and v mode quadrature variances are minimal for the same value of θ [13]. The optimal correlations produced in the system are directly related to the quantum noise properties of these modes u, v . Indeed, the maximally correlated modes a^*, b^* are

$$A_{a^*} = (A_u + iA_v)/\sqrt{2}, \quad A_{b^*} = (A_u - iA_v)/\sqrt{2}, \quad (3)$$

and the minimum value of $I_{a,b}$ is then given by the sum of the u, v mode minimal noises

$$I_{a^*,b^*} = \min_{a,b,\theta} I_{a,b}(\theta) = \min_{\theta} [\Delta^2 X_u(\theta) + \Delta^2 X_v(\theta)]. \quad (4)$$

Consequently, if one or two of the u, v modes are squeezed, the value I_{a^*,b^*} corresponding to maximal correlations is equal to the sum of their squeezing. Experimentally, one has to look for the u - and v -type modes, a signature of which being that $I_{u,v}(\theta)$ does not depend on θ [see (2)], and measure their squeezing (if any). The maximally correlated modes are then given by (3) and the amount of their EPR-type correlations by (4).

Let us note that modes u, v are not *stricto sensu* uncorrelated, since $\langle \delta A_u \delta A_v^\dagger \rangle$ can be nonzero. However, one can think of the correlation properties of modes a^*, b^* as being created by the mixing of the u and v modes, as it is usually produced by mixing two independent squeezed beams [2,4,6]. Let us stress that this analysis provides a general framework for finding out the maximal correlations produced in a two-mode system exhibiting quantum properties. This method is of interest for a class of systems such as the optical parametric oscillator in which the correlations are not produced by mixing independent beams [14].

Coming back to our system, which is symmetrical with respect to the circularly polarized modes A_{\pm} , it is easy to see that $\langle \delta A_x \delta A_y \rangle = 0$ because A_x and A_y are combinations with equal weights of A_{\pm} . Since they are squeezed for orthogonal quadratures, one can set $A_u = A_x$ and $A_v = iA_y$, which are now squeezed for the same quadrature. Then, using (3), the maximally entangled modes are the $\pm 45^\circ$ modes to the x, y basis. This gives us the relevant quantity, $I_{+45,-45}(\theta)$, which is to be measured. Using $A_{\pm 45} = (A_x \pm A_y)/\sqrt{2}$, the inseparability criterion for the $\pm 45^\circ$ modes can be expressed directly in terms of the x, y mode variances with $X_u(\theta) = X_x(\theta)$ and $X_v(\theta) = Y_y(\theta)$:

$$I_{+45,-45}(\theta) = \Delta^2 X_x(\theta) + \Delta^2 Y_y(\theta) < 2. \quad (5)$$

When θ corresponds to the angle θ_{sq} of the squeezed quadrature of A_x , both variances are below unity, and $I_{+45,-45}(\theta_{sq}) < 2$.

In order to experimentally check the inseparability criterion (5), we need to simultaneously measure the fluctuations of A_x and iA_y . After the output of the cavity, we insert a quarter-wave plate that rotates the noise ellipsoid of vacuum mode A_y by $\pi/2$, the beam is mixed on a beam splitter with a local oscillator (LO), and the two resulting beams are sent into two balanced homodyne detections [Fig. 1]. Thus, we simultaneously measure the quadrature noise of each beam for the same quadrature. The sum of these two signals directly gives the sought quantity $I_{+45,-45}(\theta)$. In Fig. 2(b), we plot a typical measurement of $I_{+45,-45}$ as a function of θ , for an analysis frequency of 5 MHz. Its minimal value is about 1.9 [1.86 corrected from losses] and corresponds to a case for which A_x and iA_y are both squeezed by about 5% [Fig. 2(a)]. *Quadrature entanglement* is thus achieved in a frequency range given by the cavity bandwidth (3 to 12 MHz).

Consistently with the general method described above, we also checked that modes A_x and iA_y correspond indeed to u, v -type modes. We therefore measured the quantity $I_{x,y}$ in a similar manner as $I_{+45,-45}$, and verified that it is independent of θ [Fig. 2(c)], thus proving that modes A_{+45} and A_{-45} exhibit maximal EPR-type correlations.

Moreover, we note that our measurement not only demonstrates entanglement, but also quantifies it via the

entanglement of formation. Following Giedke *et al.* [10], we introduce the covariance matrix (CM) γ for the $\pm 45^\circ$ polarized modes:

$$\gamma_{i,j} = \langle \delta R_i \delta R_j + \delta R_j \delta R_i \rangle / 2,$$

where $\{R_i, i = 1, \dots, 4\} = \{X_{+45}, Y_{+45}, X_{-45}, Y_{-45}\}$. Using the fact that A_x and iA_y are uncorrelated and symmetrical [see Figs. 2(b) and 2(c)], it is straightforward to show that the $\pm 45^\circ$ modes have isotropic fluctuations. Choosing $\theta = \theta_{sq}$, the covariance matrix can be expressed in the standard form given in Ref. [10]:

$$\gamma = \begin{pmatrix} n & 0 & k & 0 \\ 0 & n & 0 & -k \\ k & 0 & n & 0 \\ 0 & -k & 0 & n \end{pmatrix}, \quad (6)$$

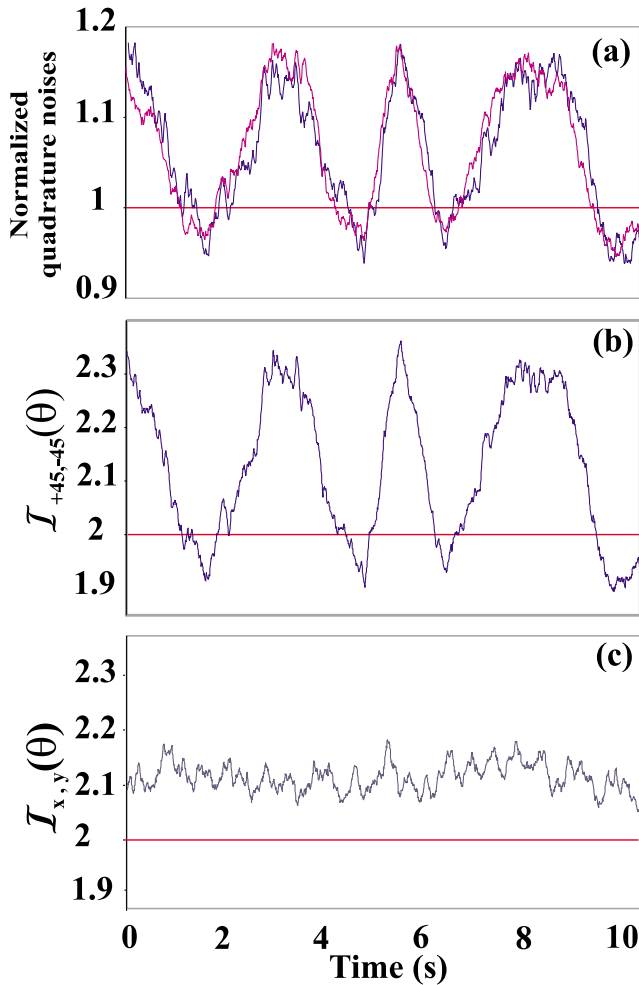

FIG. 2 (color online). (a) Quadrature noise spectra of A_x and iA_y , at a frequency of 5 MHz, when the relative phase θ between the LO and the mean field mode is varied in time. (b) Direct measurement of $I_{+45,-45}(\theta)$. (c) Corresponding measurement of $I_{x,y}(\theta)$.

with $n = \Delta^2 X_{\pm 45} = \Delta^2 Y_{\pm 45}$ and $k = \langle \delta X_{+45} \delta Y_{-45} \rangle = \langle \delta X_{-45} \delta Y_{+45} \rangle$ [15]. As calculated by Giedke *et al.*, the EOF \mathcal{E} , representing the amount of pure state entanglement needed to prepare our entangled state [16], is then directly related to the inseparability criterion value by [10]

$$\mathcal{E} = f(n - k) = f[I_{+45,-45}(\theta_{sq})/2], \quad (7)$$

with $f(x) = c_+(x) \log_2[c_+(x)] - c_-(x) \log_2[c_-(x)]$ and $c_{\pm}(x) = (x^{-1/2} \pm x^{1/2})^2/4$. For $I_{+45,-45} = 1.86 \pm 0.02$, the EOF is $\mathcal{E} = 0.014 \pm 0.003$.

Last, we show that this quadrature entangled beam allows to generate *polarization entanglement*. Polarization entanglement for two beams α and β [5] is achieved when

$$I_{\alpha,\beta}^S = \frac{1}{2}[\Delta^2(S_2^\alpha + S_2^\beta) + \Delta^2(S_3^\alpha + S_3^\beta)] < |\langle S_1^\alpha \rangle| + |\langle S_1^\beta \rangle|,$$

where the $S_i^{\alpha,\beta}$ are the standard quantum Stokes operators. For this, we produce new modes by mixing the $A_{\pm 45}$ modes studied previously with additional strong fields. The $A_{\pm 45}$ modes are obtained from the x, y modes by passing the beam through a half-wave plate with axes at 22.5° . The fields along the x and y directions are now the A_{+45} and A_{-45} fields, which we will denote by A'_x and A'_y [see Fig. 3]. The A'_x and A'_y are then spatially separated with a polarizing beam splitter. In the other input of the beam splitter, we send a strong field B with a polarization at 45° from the beam splitter axes, yielding the output fields B_y and B_x . The strong field B is similar to the local oscillator in the previous experiment, except that its phase θ_B is locked to that of one of the A fields by a servo loop, as shown in Fig. 3. At the two outputs of the beam splitter, we have two beams α, β which are the superposition of, respectively, A'_x and B_y , and A'_y and B_x . The Stokes operators S_i^α for one of the outputs are then

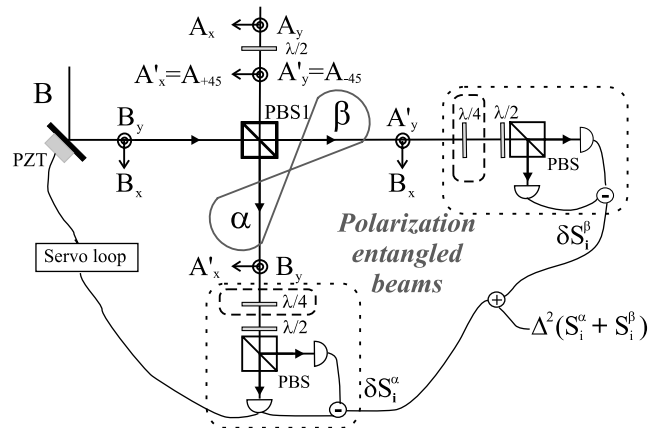

FIG. 3. Setup for nonseparable beam generation. Inserting the quarter-wave plates (or not) allows for measuring the fluctuations of $S_3^\alpha + S_3^\beta$ (or $S_2^\alpha + S_2^\beta$). The servo loop is used to lock the B field phase to the squeezed quadrature angle.

$$S_0^\alpha = A_x^{\dagger} A_x' + B_y^{\dagger} B_y', \quad S_1^\alpha = A_x^{\dagger} A_x' - B_y^{\dagger} B_y', \quad S_2^\alpha = A_x^{\dagger} B_y' + B_y^{\dagger} A_x', \quad S_3^\alpha = i(B_y^{\dagger} A_x' - A_x^{\dagger} B_y').$$

The Stokes operators S_i^β for the other output are obtained by exchanging A' and B in the previous expression. Since the B field is much stronger than the A field, one has $|\alpha_B| \gg |\alpha_{A'}|$, with α_B the amplitude of B_x and B_y and $\alpha_{A'}$ the amplitude of A_x' and A_y' . Then $\langle S_1^\alpha \rangle = -\langle S_1^\beta \rangle \approx -|\alpha_B|^2$ and the inseparability condition reads

$$I_{\alpha,\beta}^S < 2|\alpha_B|^2. \quad (8)$$

In this case, the Stokes parameter fluctuations are related to those of the initial $\pm 45^\circ$ modes (now denoted A_x', A_y')

$$\delta S_2^\alpha = \alpha_B \delta X_x'(\theta_B), \quad \delta S_2^\beta = \alpha_B \delta X_y'(\theta_B), \quad (9)$$

$$\delta S_3^\alpha = -\alpha_B \delta Y_x'(\theta_B), \quad \delta S_3^\beta = \alpha_B \delta Y_y'(\theta_B), \quad (10)$$

which straightforwardly lead to

$$I_{\alpha,\beta}^S = |\alpha_B|^2 I_{A_x', A_y'}(\theta_B) \equiv |\alpha_B|^2 I_{+45, -45}(\theta_B).$$

The polarization entanglement condition (8) is thus equivalent to the inseparability criterion (5) for the $\pm 45^\circ$ modes when $\theta_B = \theta_{sq}$. Therefore, quadrature entanglement can be mapped into a polarization basis and lead to polarization entanglement [6]. Experimentally, we use the setup shown in Fig. 3 and lock the phase of the B

field with the squeezed quadrature angle. We then successively measure the S_2 and S_3 Stokes operator noises using the appropriate combination [5] of plates and polarizing beam splitter (PBS). In Fig. 4, we present the normalized quadrature noises of $S_2^\alpha + S_2^\beta$ and $S_3^\alpha + S_3^\beta$ for an analysis frequency of 5 MHz. This entanglement between the beams corresponds to a reduction by approximately 5% in the noise of each variable: $I_{\alpha,\beta}^S/|\alpha_B|^2 = 1.9$, consistently with the quadrature entanglement measurement. From (9) and (10), it is also clear that the CM has the same form as (6).

In conclusion, we have reported the generation of continuous variable entanglement via the interaction with cold atoms in cavity. First, we have developed a method to directly measure the inseparability criterion [8] and demonstrated quadrature entanglement between two orthogonally polarized modes. The entanglement was quantified using the entanglement of formation calculated in Ref. [10]. Second, we achieve polarization entanglement after mapping the quadrature entanglement onto two spatially separated beams.

This work was supported by the QIPC European Project No. IST-1999-13071 (QUICOV).

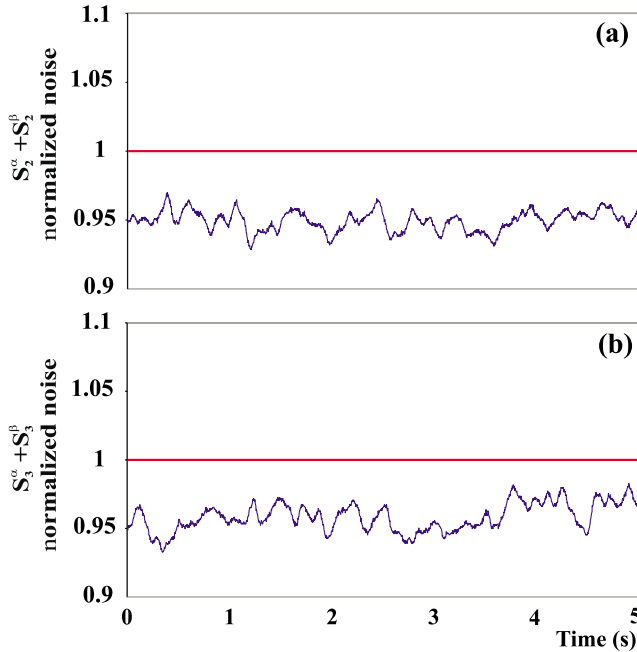

FIG. 4 (color online). Normalized noises at 5 MHz of $S_2^\alpha + S_2^\beta$ (a) and $S_3^\alpha + S_3^\beta$ (b), the phase θ_B being locked with the value of the squeezed quadrature angle θ_{sq} .

- [1] C. H. Bennett *et al.*, Phys. Rev. Lett. **70**, 1895 (1993); S. L. Braunstein and H. J. Kimble, Phys. Rev. A **61**, 042302 (2000); D. P. DiVincenzo, Science **270**, 255 (1995); B. Julsgaard *et al.*, Nature (London) **413**, 400 (2001).
- [2] Z. Y. Ou *et al.*, Phys. Rev. Lett. **68**, 3663 (1992).
- [3] Y. Zhang *et al.*, Phys. Rev. A **62**, 023813 (2000).
- [4] C. Silberhorn *et al.*, Phys. Rev. Lett. **86**, 4267 (2001).
- [5] N. Korolkova *et al.*, Phys. Rev. A, **65**, 052306 (2002); N. Korolkova *et al.*, Eur. Phys. J. D **18**, 229 (2002).
- [6] W. P. Bowen *et al.*, Phys. Rev. Lett. **89**, 253601 (2002); W. P. Bowen *et al.*, Phys. Rev. Lett. **90**, 043601 (2003).
- [7] O. Glöckl *et al.*, J. Opt. B **5**, S492 (2003); O. Glöckl *et al.*, Phys. Rev. A **68**, 012319 (2003).
- [8] L. M. Duan *et al.*, Phys. Rev. Lett. **84**, 2722 (2000); R. Simon, Phys. Rev. Lett. **84**, 2726 (2000).
- [9] V. Josse *et al.*, Phys. Rev. Lett. **91**, 103601 (2003).
- [10] G. Giedke *et al.*, Phys. Rev. Lett. **91**, 107901 (2003).
- [11] A. Einstein *et al.*, Phys. Rev. **47**, 777 (1935).
- [12] V. Josse *et al.*, J. Opt. B **5**, S513 (2003).
- [13] V. Josse *et al.* (to be published).
- [14] L. Longchambon *et al.*, quant-ph/0311123; H. Adamy and G. Kryuchkyan, quant-ph/0309203; S. Feng and O. Pfister, quant-ph/0310002.
- [15] The factor 1/2 in our definition for the CM comes from our definition of the quadrature operators.
- [16] C. H. Bennett *et al.*, Phys. Rev. A **54**, 3824 (1996).