

Search for Exchange-Antisymmetric States for Spin-0 Particles at the 10^{-11} Level

D. Mazzotti,^{1,2} P. Cancio,¹ G. Giusfredi,¹ M. Inguscio,² and P. De Natale¹

¹*Istituto Nazionale di Ottica Applicata (INOA), Largo E. Fermi 6, I-50125 Firenze, Italy*

²*Istituto Nazionale per la Fisica della Materia (INFM) and European Laboratory for Nonlinear Spectroscopy (LENs), Largo E. Fermi 2, I-50125 Firenze, Italy*

(Received 23 August 2000)

We set a new upper limit of 1.7×10^{-11} to the probability that two spin-0 ^{16}O nuclei are in forbidden exchange-antisymmetric states, testing the validity of fundamental principles of quantum mechanics. A newly designed difference-frequency spectrometer is used to look for the existence of these states. The experimental test was performed by tuning the spectrometer across a molecular transition of $^{12}\text{C}^{16}\text{O}_2$ belonging to the rovibrational band at $4.25 \mu\text{m}$, connecting the forbidden states $(00^0, J = 25)$ and $(00^0, J = 26)$.

DOI: 10.1103/PhysRevLett.86.1919

PACS numbers: 05.30.Jp, 21.10.Hw, 33.20.-t, 42.62.Fi

Although the symmetrization postulate (SP) constitutes the basis for a quantum-mechanical description of any system of identical particles, the possibility of theories going beyond the Bose and Fermi statistics, arising from the SP, has long been recognized [1,2]. More recently, theories allowing small SP violations have been developed, basically following two different approaches. In the first approach, trilinear commutation relations are defined instead of the usual bilinear Bose and Fermi commutators [3], whereas in the second a slight deformation of the bilinear commutation relations is introduced, using a parameter which can continuously turn each statistics into the other [4].

At present, no experimental evidence of SP violation has been demonstrated. The most accurate tests of the SP were performed on fermions, which must obey the Pauli exclusion principle (PEP), which is a particular case of the SP. Ramberg and Snow [5] searched for a PEP-forbidden electronic transition in a copper strip with electrical current flowing through it for hundreds of hours. The negative result of this experiment was interpreted to give an upper limit of 1.7×10^{-26} to PEP violation for a many-electron system. A simpler and more rigorously interpreted two-fermion system, the helium atom, was investigated by Deilamian *et al.* [6]. They adopted a spectroscopic technique to search for an electronic transition involving a PEP-forbidden state. This experiment set 5×10^{-6} as a bound to PEP violation for a two-electron system. An experimental evidence of SP violation in a system of bosons is harder to be observed. Nevertheless, some tests were first proposed [7,8] and then performed, searching for forbidden exchange-antisymmetric states in molecules containing two identical ^{16}O nuclei (spin-0 bosons). Two independent spectroscopic tests on $^{16}\text{O}_2$ set the bound to a SP violation, respectively, to 5×10^{-7} [9] and 1.3×10^{-6} [10]. The first test on $^{12}\text{C}^{16}\text{O}_2$, due to the stronger allowed transitions involved in the measurement, improved upon the previous ones by more than 2 orders of magnitude, setting an upper limit of 2.1×10^{-9} to SP violations [11]. Recent discussion on the theoretical implications of these experimental tests can be found in Ref. [12].

The choice of a suitable test molecule/transition both depends on bare physics and on the availability of a proper source of coherent radiation at the corresponding wavelength. From the point of view of the general physical properties, diatomic homonuclear molecules, such as $^{16}\text{O}_2$, are not the best choice for the test, because of their lack of active electric dipole transitions in the infrared (IR). Higher sensitivity to look for the existence of exchange-antisymmetric states can be achieved by investigation of polyatomic molecules containing a pair of identical bosonic nuclei. Among them the $^{12}\text{C}^{16}\text{O}_2$ molecule is one of the best candidates because its rovibrational IR transitions may have line strengths up to 3.5×10^{-18} cm/molecule. In Ref. [11], the 12^01-00^00 combination band of $^{12}\text{C}^{16}\text{O}_2$ around a $2 \mu\text{m}$ wavelength was chosen, since it is the strongest that can be reached by available distributed-feedback diode lasers.

In this Letter, following the original idea of Hilborn [7], we report on a new sensitive search of the existence of exchange-antisymmetric states for spin-0 particles, which was performed by investigating the spectrum of the 00^01-00^00 fundamental band of $^{12}\text{C}^{16}\text{O}_2$ around $4.25 \mu\text{m}$. This band is about 2000 times stronger than the 12^01-00^00 , providing us with a higher sensitivity. The high-sensitivity spectroscopic investigation of this band was made possible by the recent development of a difference-frequency radiation source at this wavelength, with the desired features of wide tunability, narrow linewidth, and low intensity noise [13]. These features, in a previous experiment, had also allowed us to observe low-power saturated-absorption spectra of CO_2 [14].

According to the Born-Oppenheimer approximation, the total wave function Ψ of a single molecule can be factorized in the form $\Psi = \psi_e \psi_v \psi_r \psi_n$, where ψ_e , ψ_v , ψ_r , and ψ_n are the electronic, vibrational, rotational, and nuclear wave functions, respectively. The ground electronic and vibrational wave functions of the $^{12}\text{C}^{16}\text{O}_2$ molecule are symmetric in the exchange of the two ^{16}O nuclei. Also, the nuclear wave function is symmetric, since the nuclear spin $I(^{16}\text{O}) = 0$. The rotational wave

function is symmetric for even values of J , antisymmetric for odd ones. The SP requires the total wave function to be symmetric in the exchange of the two ^{16}O nuclei. Therefore rotational states with odd values of J are forbidden in the ground vibrational state. A similar argument could show that the situation is reversed in the 00^01 vibrational state, for which even values of J are forbidden, because the vibrational wave function ψ_v in the excited state is antisymmetric. As a consequence, detection of a weak transition of the rovibrational form $00^01-00^00 R(J)$ with an odd value of J could indicate a SP violation and its amount.

The experimental setup is shown in Fig. 1. The $4.25\text{-}\mu\text{m}$ radiation is generated by a nonlinear three-wave frequency mixing occurring in a periodically poled lithium niobate (PPLN) crystal. The 17.5 mm long PPLN crystal is pumped by a continuous-wave, single-mode Nd:YAG laser (maximum output power = 800 mW , wavelength $\sim 1064\text{ nm}$), as well as by a slave diode laser (SDL) that delivers a maximum output power of 150 mW at 850 nm . The SDL is injection locked by a low-power master diode laser at the same wavelength, mounted in an extended-cavity configuration. The diode laser system has a step-wise tuning range of about 10 nm (with a $\sim 7.5\text{ GHz}$ step size) and a fast linewidth $< 1\text{ MHz}$. Synchronous scans of the extended-cavity length and of the driving currents of both diode lasers allow continuous frequency spans wider than 15 GHz . A dichroic mirror combines the two s -polarized laser beams which are focused by a lens into the PPLN crystal to a waist of about $30\text{ }\mu\text{m}$. To achieve optimal quasiphase-matching, the crystal is mounted in a thermally insulated copper oven, controlled at a temperature of 287°C . The IR beam is focused into a White-type multipass absorption cell [15] to a waist of about $300\text{ }\mu\text{m}$, while

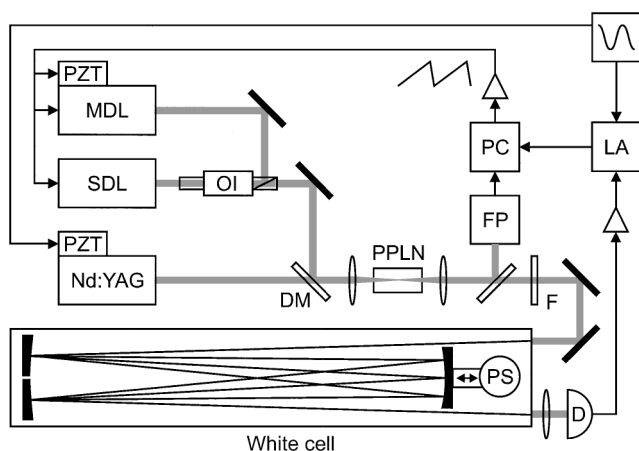

FIG. 1. Experimental setup. MDL: master diode laser; SDL: slave diode laser; PZT's: piezoelectric translators; OI: optical isolator; DM: dichroic mirror; PPLN: periodically poled LiNbO_3 crystal; PC: computer; LA: lock-in amplifier; FP: Fabry-Perot cavity; F: Ge filter; PS: phase-scrambler; D: InSb detector.

the input beams are blocked by an antireflection-coated Ge filter. The 2 m long cell allows one to obtain optical absorption lengths in excess of 130 m . Our White-type design is affected by fringes with a spacing of 37.5 MHz that corresponds to the optical path of 8 m between two close spots on the input/output mirror. In order to reduce fringing noise, we limit the maximum path length to 112 m , and we modulate it by moving the input/output mirror using a small electric engine [phase scrambler] [16]. We do not observe, either for the alignment He-Ne laser or the IR radiation, any significant degradation of the beam quality at the cell output, mainly due to the good optical quality of the gold-coated mirror surfaces (better than $\lambda/10$ at 633 nm). After the cell, IR radiation is focused onto a liquid- N_2 -cooled InSb photovoltaic detector.

Frequency modulation of the Nd:YAG laser emission is obtained by applying a sinusoidal voltage (at a 2 kHz rate) onto a PZT glued on the monolithic ring cavity. First-derivative recording, using a lock-in amplifier, is used, in order to get rid of the constant background seen by the detector that severely limited the dynamic range of signal processing. Further reduction of fringing noise is achieved by a filtering technique that consists of selecting a particular width of the frequency modulation. Indeed, it can be noticed that, as the modulation width varies, the fringe visibility changes quasiperiodically, passing through minimum points. This phenomenon is analogous to the fringe visibility curve that can be observed in classical interference experiments, such as the Fresnel's mirrors with a slit source [17]. We use a modulation width of about 120 MHz , which, for our fringe spacing, corresponds to the third minimum of the fringe visibility. Since the Doppler linewidth is 132 MHz (FWHM), this is also a convenient value for the first-derivative detection. It is worth remarking that this fringe cancellation technique can be used when the fringe spacing is not significantly larger than the linewidth.

We chose the forbidden $00^01-00^00 R(25)$ line (2367.265 cm^{-1}) for the test, because it satisfies three requirements: (i) It is close to the strongest R -branch lines (at room temperature); (ii) it is far from any strong allowed line; (iii) a weak line to be used as a frequency and sensitivity marker is well separated from the forbidden line and can be recorded within the frequency span. In Fig. 2, a recording of our marker line $02^21-02^20 R(80)$ of $^{12}\text{C}^{16}\text{O}_2$ (2367.230 cm^{-1}) is shown. Pure carbon dioxide (99.99%) is used to fill the cell at pressures ranging from 270 to 330 Pa . These pressures are chosen in order to minimize the absorption due to the Lorentzian wings of the strong $R(24)$ and $R(26)$ lines and still maintain a good S/N ratio in the spectral region of interest. We fit the experimental points to an approximate function, taking into account the Doppler and the pressure-broadened linewidths, the frequency modulation, and a parabolic background. The fit line shape was simply obtained by taking the difference between two Voigt profiles, frequency-spaced by

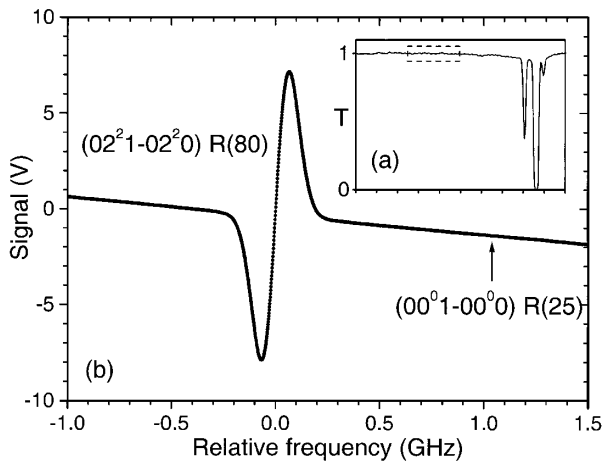

FIG. 2. (a) Transmission spectrum (10 GHz total frequency span) of the White cell filled with 18 Pa of CO_2 (path length = 56 m). Absorption peaks of three CO_2 lines around 2367.4 cm^{-1} are shown. (b) Plot of the first-derivative demodulated signal. This scan, corresponding to the dashed rectangle in (a), contains the $R(80)$ marker line and the region where the forbidden $R(25)$ line is expected. A fit curve (solid line) is superimposed on the experimental points.

an amount related to the modulation width. It is worth noticing the good agreement of the experimental points with the fit function, though the recording time is as long as eight hours. To make it possible, we first improved the long term passive stability of the IR source system, reducing the frequency drift down to about 80 MHz/h; second, we implemented a routine that allows us to average different scans, even if recorded in different days, by compensating for the residual drift. Each scan lasts about 10 s and a relative frequency scale, with an accuracy of about 1%, is provided by synchronous recording of the transmission peaks of the diode laser (SDL), passing through a Fabry-Perot interferometer with a free spectral range of 1.5 GHz. We assume that the frequency of the $R(25)$ line has the same uncertainty (about 15 MHz) as the nearby $R(24)$ and $R(26)$ allowed transitions [18]. Considering that also the marker line has an uncertainty of about 15 MHz [18], an estimate for the uncertainty of the frequency gap between the marker and the forbidden line is 30 MHz. IR wavelengths are calculated by measuring both diode and Nd:YAG laser wavelengths using a wave meter with a precision of 300 MHz. In Fig. 2, an arrow indicates the calculated position of the forbidden line. Figure 3 shows this spectral region with an expanded vertical scale. In this recording, noise is dominated by interference fringes and laser intensity fluctuations. The violation parameter $\beta^2/2$ [3] can be expressed, in our case, as [19]

$$\beta^2/2 < \frac{A_{R(25)} S_{R(80)}}{A_{R(80)} S_{R(25)}}, \quad (1)$$

where $A_{R(25)}$ and $A_{R(80)}$ are the signals corresponding to the forbidden and marker line, respectively; $S_{R(80)}$ is the line

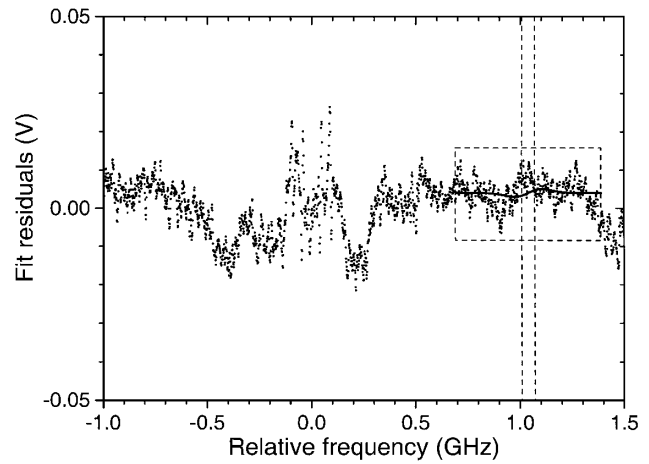

FIG. 3. Plot of the fit residuals from Fig. 2 with an expanded vertical scale (200 \times). The two vertical dashed lines delimit the expectation interval (± 30 MHz) for the center frequency of the $R(25)$ line. The dashed rectangle includes the frequency region where the rms noise has been estimated and also contains the fit curve.

strength of the marker line, while $S_{R(25)}$ is the calculated line strength of the forbidden line. The main dependence of the line strength of a rovibrational R -branch line on J and T is [20]

$$S(J, T) \propto (J + 1) \exp\left[-\frac{h\nu_0 + E_r(J)}{k_B T}\right], \quad (2)$$

where h is the Planck constant, k_B is the Boltzmann constant, ν_0 is the band center frequency, and $E_r(J)$ is the rotational energy. The line strength $S_{R(25)}$ can be easily calculated from Eq. (2) as

$$S(25, T) \approx S(24, T) \frac{26}{25} \exp\left(-\frac{50hB}{k_B T}\right), \quad (3)$$

where $B = 0.389 \text{ cm}^{-1}$. $A_{R(25)}$ can be estimated by measuring the root mean square (rms) noise in the spectral range where the forbidden line is expected [9,11], or by fitting the experimental data to the proper line shape function, leaving its center frequency and linewidth fixed [10]. Of course, the first approach gives a more conservative estimate, whereas the second procedure is more stringent, though more sensitive to small local fluctuations. We give both estimates below.

In Fig. 3, a first derivative of a Gaussian function (solid line) is used to fit the experimental data. The resulting amplitude is $A_{R(25)} = 2.0(6) \text{ mV}$, i.e., the value is within about 3σ (standard error of the fit). On the other hand, a calculation of rms noise in the same interval gives $A_{R(25)} = 3.7 \text{ mV}$. We moved the line center of the fitting curve within the combined uncertainty of the frequency gap between marker and forbidden line (± 30 MHz), obtaining all amplitudes within 6σ . By moving the line center also outside this frequency interval, we could fit a few features with an amplitude exceeding the uncertainty.

Therefore, we took the rms value to infer an upper bound to the violation.

Considering that $A_{R(80)} = 14.7$ V, $S_{R(24)} = 2.78 \times 10^{-18}$ cm/molecule, and $S_{R(80)} = 1.81 \times 10^{-25}$ cm/molecule (for $T = 296$ K), we can infer that $\beta^2/2 < 1.7 \times 10^{-11}$. This means that the minimum detectable partial pressure of molecules in exchange-antisymmetric states with our setup is lower than 5 nPa, corresponding to about 3×10^{10} molecules in the total cell volume (about 25 liters). Considering that the IR beam occupies about $\frac{1}{30}$ of this volume, the maximum number of molecules in exchange-antisymmetric states that are interrogated at each time is 10^9 . It is worth pointing out that this large number of molecules, and the related number of absorbed photons, makes the absorption process stationary. This justifies the assumption of a Gaussian function, arising from Boltzmann statistics, to fit the forbidden line.

Substantial improvements to the sensitivity for this class of spectroscopic tests could be obtained by extending external-cavity-enhancement techniques, such as the so-called NICE-OHMS [21], to the infrared region, where the strongest rovibrational transitions can be found. Profitable use of this technique is, at present, conditioned by the development of high-reflectivity and very-low-loss mirrors as well as fast detectors for this spectral region. Other spectroscopic techniques, such as ionization [22] or photon burst spectroscopy [23], could provide alternative sensitive tools to search for small deviations from conventional statistics.

The authors acknowledge G. Modugno for the useful discussions, D. Bailly and S. A. Tashkun for the references on CO₂, G. Di Lonardo for the multipass cell facility, L. W. Hollberg for providing us with the nonlinear crystal, and P. Bianchi for manufacturing the cell mirrors. D. Mazzotti acknowledges Agenzia Spaziale Italiana (ASI) for his grant.

- [1] G. Gentile, *Nuovo Cimento* **17**, 493 (1940).
- [2] H. S. Green, *Phys. Rev.* **90**, 270 (1953).
- [3] O. W. Greenberg and R. N. Mohapatra, *Phys. Rev. Lett.* **59**, 2507 (1987); *Phys. Rev. Lett.* **61**, 1432(E) (1988); *Phys. Rev. Lett.* **62**, 712 (1989).
- [4] O. W. Greenberg, *Phys. Rev. Lett.* **64**, 705 (1990); *Phys. Rev. D* **43**, 4111 (1991).
- [5] E. Ramberg and G. A. Snow, *Phys. Lett. B* **238**, 438 (1990).
- [6] K. Deilamian, J. D. Gillaspay, and D. E. Kelleher, *Phys. Rev. Lett.* **74**, 4787 (1995).
- [7] R. C. Hilborn, *Bull. Am. Phys. Soc.* **35**, 982 (1990).
- [8] G. M. Tino, *Nuovo Cimento Soc. Ital. Fis.* **16D**, 523 (1994).
- [9] M. de Angelis *et al.*, *Phys. Rev. Lett.* **76**, 2840 (1996).
- [10] R. C. Hilborn and C. L. Yuca, *Phys. Rev. Lett.* **76**, 2844 (1996).
- [11] G. Modugno, M. Inguscio, and G. M. Tino, *Phys. Rev. Lett.* **81**, 4790 (1998).
- [12] *Spin-Statistics Connection and Commutation Relations*, edited by R. C. Hilborn and G. M. Tino, AIP Conf. Proc. No. 545 (AIP, New York, 2000).
- [13] D. Mazzotti *et al.*, *Appl. Phys. B* **70**, 747 (2000).
- [14] D. Mazzotti *et al.*, *Opt. Lett.* **25**, 350 (2000).
- [15] J. U. White, *J. Opt. Soc. Am.* **32**, 285 (1942).
- [16] P. De Natale *et al.*, *Appl. Opt.* **36**, 5822 (1997).
- [17] M. Born and E. Wolf, *Principles of Optics* (Pergamon, Oxford, 1980).
- [18] M. P. Esplin *et al.*, Report No. AFGL/TR/0046, 1986; S. A. Tashkun *et al.*, *J. Quant. Spectrosc. Radiat. Transfer* **60**, 785 (1998).
- [19] G. Modugno, Ph.D. thesis, Scuola Normale Superiore, Pisa, Italy, 1999.
- [20] L. S. Rothman *et al.*, *J. Quant. Spectrosc. Radiat. Transfer* **48**, 537 (1992).
- [21] J. Ye, L.-S. Ma, and J. L. Hall, *J. Opt. Soc. Am. B* **15**, 6 (1998); L. Gianfrani, R. W. Fox, and L. W. Hollberg, *J. Opt. Soc. Am. B* **16**, 2247 (1999).
- [22] G. S. Hurst *et al.*, *Rev. Mod. Phys.* **51**, 767 (1979).
- [23] G. W. Greenlees *et al.*, *Opt. Commun.* **23**, 236 (1977); K. Deilamian, J. D. Gillaspay, and D. E. Kelleher, *J. Opt. Soc. Am. B* **10**, 789 (1993).