

Three-Dimensional Josephson-Junction Arrays in the Quantum Regime

T. K. Kopec¹ and Jorge V. José²

¹*Institute for Low Temperature and Structure Research, Polish Academy of Sciences, POB 1410, 50-950 Wroclaw 2, Poland*

²*Physics Department and Center for Interdisciplinary Research on Complex Systems, Northeastern University, Boston, Massachusetts 02115*

(Received 18 August 1999)

We study the quantum phase transition properties of a three-dimensional periodic array of Josephson junctions with charging energy that includes both the self and mutual junction capacitances. We use the phase fluctuation algebra between number and phase operators, given by the Euclidean group E_2 , and we effectively map the problem onto a solvable quantum generalization of the spherical model. We obtain a phase diagram as a function of temperature, Josephson coupling, and charging energy. We also analyze the corresponding fluctuation conductivity and its universal scaling form in the vicinity of the zero-temperature quantum critical point.

PACS numbers: 74.50.+r, 67.40.Db, 73.23.Hk

There is significant contemporary interest in quantum critical phenomena. Most studies have been carried out in two dimensions [1]. There are several systems where theoretical results have been successfully compared against experiment in artificial networks [2] and homogeneous ultrathin films [3]. There has been some, but much less, work in the three-dimensional (3D) case, although there is both theoretical and experimental interest in this problem, for example, in quantum magnetic systems and high-temperature superconductors. There is also preliminary progress in fabricating quasi-three-dimensional Josephson junction arrays (JJA) with ultrasmall junctions, in which quantum fluctuations are essential [4]. There is also interest in the classical limit of bulk high- T_c superconductors where the scaling critical properties are dominated by thermal fluctuations [5]. Closely related is also the physics that governs the interplay between local and global superconductivity in granular materials, in which disorder may also play an important role. In spite of this interest, however, 3D quantum-capacitive JJA have not been investigated in depth yet. Notably, there appear to be no studies on 3D JJA close to the $T = 0$ quantum-critical (QC) point, where the physics is dominated by zero-point quantum fluctuations rather than thermal effects. When the superconducting islands can sustain at least one Cooper pair, the development of global superconducting phase coherence depends on the relative strength of the interisland Josephson coupling E_J , as compared to the charging energy $E_C = e^2/2C$, where C is the junction capacitance. In the *quantum* regime the phase-charge interplay is a direct consequence of the Heisenberg uncertainty relations between the island phase ϕ_j and the particle number operator $L_j = i\partial/\partial\phi_j$. In this paper we investigate a general quantum-capacitive model for 3D JJA on the simple cubic lattice. We establish the general phase transition boundary and present results for the measurable frequency dependent conductivity in the QC regime. We employ a novel non-mean-field approach based on the proper quantum phase fluctuation algebra, by mapping the 3D JJA model onto

an effectively constrained system—a solvable quantum-spherical model.

We start by defining a cubic Josephson junction array with superconducting phases ϕ_i at the 3D lattice sites i . The corresponding effective Euclidean action, in the Matsubara “imaginary time” τ formulation ($0 \leq \tau \leq 1/k_B T \equiv \beta$, with T being the temperature) is $S[\phi] = S_C[\phi] + S_J[\phi]$, where

$$S_C[\phi] = \frac{1}{8e^2} \sum_{ij} \int_0^\beta d\tau \left(\frac{\partial \phi_i}{\partial \tau} \right) C_{ij} \left(\frac{\partial \phi_j}{\partial \tau} \right), \quad (1)$$

$$S_J[\phi] = \sum_{\langle ij \rangle} \int_0^\beta d\tau J_{ij} \{1 - \cos[\phi_i(\tau) - \phi_j(\tau)]\}.$$

Here $S_C[\phi]$ defines the electrostatic energy, with C_{ij} being the geometric capacitance matrix of the array. This matrix is normally approximated both theoretically and in experimental interpretations as $C_{ij} = (C_s + zC_m)\delta_{ij} - C_m \sum_d \delta_{i,j+d}$, with the vector d running over nearest neighbors, with C_s the self-capacitance and C_m the mutual capacitance between nearest neighbors (z stands for the coordination number). There are more general forms of the full capacitance matrix [6], but in our analysis the mutual capacitance approximation is sufficient. Finally, $S_J[\phi]$ gives the Josephson energy E_J (with $J_{ij} \equiv E_J$ for $|i - j| = |d|$ and zero otherwise).

Most analytical works on quantum JJA have employed different kinds of mean-field-like approximations [7–10], which are not fully reliable to treat spatial and temporal quantum phase fluctuations. Furthermore, as pointed out recently [11], the JJA model (1) must encode the phase fluctuation algebra given by the Euclidean group E_2 that involves the commutation relations between particle L_j and phase (ladder) operators $P_j = e^{i\phi_j}$: $[L_i, P_j] = -P_j \delta_{ij}$, $[L_i, P_j^\dagger] = P_j^\dagger \delta_{ij}$, and $[P_i, P_j] = 0$ with the conserved quantity (invariant of the E_2 algebra)

$$P_i P_i^\dagger \equiv P_{xi}^2 + P_{yi}^2 = 1. \quad (2)$$

Thus, the proper theoretical treatment of a quantum JJA must maintain the constraint (2). To proceed we write the

partition function $Z = \int [\prod_i \mathcal{D}\phi_i] e^{-S[\phi]}$ for the model (1) in terms of its path integral representation [12], by introducing the auxiliary complex fields $\psi_i(\tau)$, which replace the original ladder operators P_i . To proceed, we substitute the ‘‘rigid’’ E_2 constraint given in Eq. (2) by the weaker spherical closure relation $\frac{1}{N} \sum_i P_i P_i^\dagger = 1$, which maintains (on average) the original condition of Eq. (2). This substitution allows us to formulate the problem in terms of an (exactly) soluble quantum-spherical (QS) model (see Ref. [13]). By using the Fadeev-Popov method with the Dirac delta functional, which facilitates both the change of integration variables and the imposition of the spherical constraint we obtain

$$Z = \int \left[\prod_i \mathcal{D}\psi_i \mathcal{D}\psi_i^* \right] \delta \left(\sum_i |\psi_i|^2 - N \right) e^{-S_j[\psi]} \\ \times \int \left[\prod_i \mathcal{D}\phi_i \right] e^{-S_c[\phi]} \prod_i \delta[\text{Re}\psi_i - P_i^x(\phi)] \\ \times \delta[\text{Im}\psi_i - P_i^y(\phi)]. \quad (3)$$

The convenient way to enforce the spherical constraint is to use the functional analog of the δ function representation $\delta(x) = \int_{-\infty}^{+\infty} (d\lambda/2\pi) e^{i\lambda x}$, which introduces the Lagrange multiplier $\lambda(\tau)$ thus adding an additional quadratic term (in the ψ fields) to the action (1). The evaluation of the effective action in terms of the ψ fields may be organized using the loop expansion method [14]. To second order in $\psi_i(\tau)$ we obtain the partition function of the quantum-spherical model $Z \equiv Z_{\text{QS}}$:

$$Z_{\text{QS}} = \int \left[\prod_i \mathcal{D}\psi_i \mathcal{D}\psi_i^* \right] \int \left[\frac{\mathcal{D}\lambda}{2\pi i} \right] e^{-S_{\text{QS}}[\psi, \lambda]}, \quad (4)$$

where

$$S_{\text{QS}}[\psi, \lambda] = \sum_{\langle ij \rangle} \int_0^\beta d\tau d\tau' \{ [(J_{ij} + \lambda \delta_{ij}) \delta(\tau - \tau') \\ + \Gamma_{ij}(\tau - \tau')] \psi_i^*(\tau) \psi_j(\tau') \\ - N \delta_{ij} \lambda \delta(\tau - \tau') \}. \quad (5)$$

Here, $\Gamma_{ij}(\tau - \tau')$ is the two-point phase vertex function related to the phase-phase cumulant correlation function $W_{kj}(\tau - \tau')$ by

$$\sum_k \int_0^\beta d\tau'' \Gamma_{ik}(\tau - \tau'') W_{kj}(\tau'' - \tau') = \delta_{ij} \delta(\tau - \tau'). \quad (6)$$

Explicitly,

$$W_{ij}(\tau - \tau') = \frac{1}{Z_0} \sum_{\{n_i\}} \prod_i \int_0^{2\pi} d\theta(0) \\ \times \int_{\theta(0)}^{\theta(0) + 2\pi n_i} \mathcal{D}\theta_i(\tau) \\ \times e^{i[\theta_i(\tau) - \theta_j(\tau')]} e^{-S_c[\theta]}, \quad (7)$$

where Z_0 is the statistical sum of the ‘‘noninteracting’’ system described by the action $S_c[\theta]$. Since the values of the phases ϕ_i which differ by 2π are equivalent, the path integral can be written in terms of the noncompact phase vari-

ables $\theta_j(\tau)$, defined on the unrestricted interval $(-\infty, +\infty)$, and by a set of winding numbers $\{n_j\} = 0, \pm 1, \pm 2, \dots$, which are integers running from $-\infty$ to $+\infty$ (and physically reflects the discreteness of the charge [15]), so that $\phi_j(\tau) = \theta_j(0) + 2\pi n_j \tau / \beta + \theta_j(\tau)$.

In the $N \rightarrow \infty$ thermodynamic limit the steepest descent method becomes exact; the condition that the integrand in Eq. (4) has a saddle point $\lambda(\tau) = \lambda_0$ becomes an implicit equation for λ_0 :

$$1 = \frac{1}{N} \sum_{\mathbf{k}, \omega_\ell} G(\mathbf{k}, \omega_\ell), \quad (8)$$

where $G^{-1}(\mathbf{k}, \omega_\ell) = [\lambda_0 - J(\mathbf{k}) + 2E_C + \omega_\ell^2/8E_C]$ with $\omega_\ell = 2\pi\ell/\beta$ ($\ell = 0, \pm 1, \pm 2, \dots$) being the (Bose) Matsubara frequencies and $J(\mathbf{k})$ the Fourier transform of the Josephson couplings J_{ij} , respectively. As mentioned above, we next proceed by assuming that C_{ij} has only the nearest-neighbor mutual components. For a 3D simple cubic lattice we obtain for the charging energy

$$E_C = \frac{1}{2} e^2 [\mathbf{C}^{-1}]_{ii} \\ = E_{0C} \frac{(4 - 3v_1)^{1/2} (1 - v_1)^{-1}}{\pi^2 \gamma (C_m/C_s)} \mathbf{K}(\kappa_+) \mathbf{K}(\kappa_-), \quad (9)$$

where $E_{0C} = e^2/(2C_s)$ is the charging energy for the self-capacitive model and $\mathbf{K}(x)$ stands for the complete elliptic integral of the first kind [16]. Furthermore,

$$\kappa_\pm^2 = \frac{1}{2} \pm \frac{1}{4} v_2 (4 - v_2)^{1/2} \\ - \frac{1}{4} (2 - v_2) (1 - v_2)^{1/2}, \quad (10)$$

$$v_1 = \frac{1}{2\gamma^2} [\gamma^2 + 3 - (\gamma^2 - 9)^{1/2} (\gamma^2 - 1)^{1/2}],$$

$$v_2 = v_1/(v_1 - 1),$$

where $\gamma = \frac{1}{2}(1 + zC_m/C_s)/(C_m/C_s)$. The result is plotted in Fig. 1.

As usual in spherical model calculations the phase boundary (i.e., the location of the critical points) is determined by Eq. (8) from the upper limit of the eigenvalue spectrum $\max\{J(\mathbf{k})\} = 3E_J$, associated with the onset of the phase transition—in the spherical model the

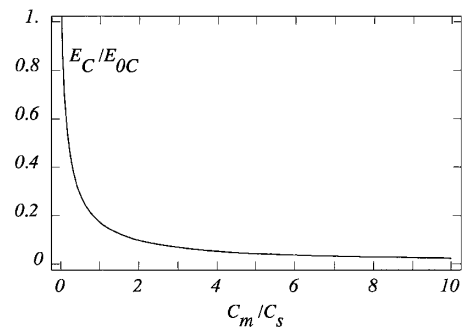

FIG. 1. Charging energy parameter for the 3D JJA as a function of the ratio of mutual C_m and self-capacitance C_s .

Lagrange multiplier λ_0 “sticks” to that value at criticality ($\lambda_0 = \lambda_0^{\text{crit}} = 3E_J$) and stays constant in the whole low-temperature phase [17]. Equivalently, at the critical point $1/G(\mathbf{k} = 0, \omega_\ell = 0) = 0$. Introducing the density of states $\rho(E) = \int_{-\pi}^{\pi} [d^3\mathbf{k}/(2\pi)^3] \delta[E - J(\mathbf{k})]$ we obtain for the critical line (Fig. 2)

$$1 = \int_{-\infty}^{+\infty} dE \rho(E) \sqrt{\frac{2E_C}{3E_J - E}} \times \coth[\beta\sqrt{2E_C(3E_J - E)}], \quad (11)$$

where $\rho(E) \equiv \rho_{s=0}(E)$ and

$$\rho_s(E) = \frac{1}{\pi^3 E_J} \int_{a_1}^{a_2} dx \Theta\left(1 - \frac{|E|}{3E_J}\right) \times \frac{A_s(x)}{\sqrt{1-x^2}} \mathbf{K}\left[\sqrt{1 - \left(\frac{E}{2E_J} + \frac{x}{2}\right)^2}\right], \quad (12)$$

with $a_1 = \max(-1, -2 - E/E_J)$, $a_2 = \min(1, 2 - E/E_J)$; $\Theta(x)$ is the unit step function and $A_0(x) = 1$.

The current response to an externally applied electromagnetic field is the conductivity σ that is experimentally measurable. In the context of two-dimensional JJA there are several studies of σ , e.g., at the superconductor-Mott-insulator using $1/N$ expansion and Monte Carlo analysis (see Ref. [18]), the coarse-grained approach [19], and an ϵ expansion [20].

The standard Kubo formula relates the conductivity to a two-point current-current correlation function. Applying an external vector potential \mathbf{A} modifies the Josephson coupling by introducing a Peierls phase factor according to $J_{ij} \rightarrow J_{ij} \exp(2ei/\hbar c \int_i^j \mathbf{A} \cdot d\mathbf{l})$. The conductivity is obtained as the second derivative of Z_{QS} given in Eq. (4) with respect to \mathbf{A} . After performing the derivatives, we obtain

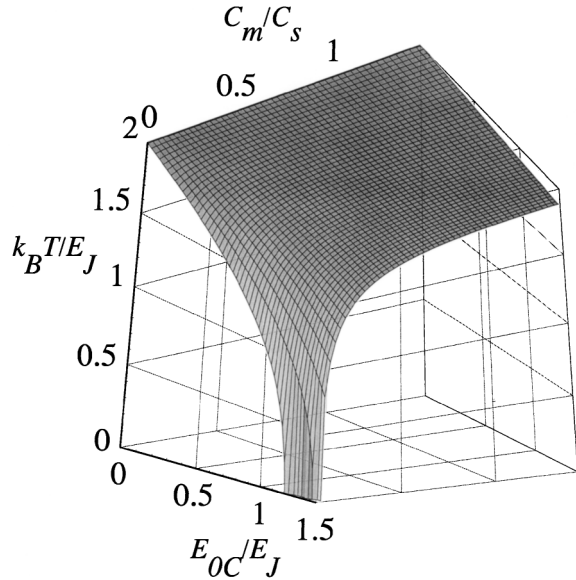

FIG. 2. Phase diagram for a 3D JJA in the parameter space defined by temperature T charging energy E_{0C} and the ratio of mutual to self-capacitance C_m/C_s of a single junction. The system is phase coherent in the region below the surface.

(for vanishing magnetic field) the longitudinal component of $\sigma(\omega_\nu) \equiv \sigma_{xx}(\omega_\nu, \mathbf{q} = 0)$ as

$$\sigma(\omega_\nu) = \frac{2\pi E_J^2}{R_Q \beta \omega_\nu} \sum_{\omega_\ell} \int_{-\infty}^{+\infty} dE \bar{\rho}(E) G(E, \omega_\ell) \times [G(E, \omega_\ell) - G(E, \omega_\nu + \omega_\ell)], \quad (13)$$

where $R_Q = h/4e^2 = 6.45 \text{ k}\Omega$ is the quantum unit of resistance. We introduced the modified density of states $\bar{\rho}(E) = \int_{-\pi}^{\pi} [d^3\mathbf{k}/(2\pi)^3] \sin^2(k_x) \delta(E - J(\mathbf{k}))$, with $\bar{\rho}(E) = \frac{1}{2}[\rho_{s=0}(E) - \rho_{s=2}(E)]$, where $\rho_s(E)$ is given in Eq. (12) with $A_2(x) = 2x^2 - 1$. Evaluating the summation over Matsubara frequencies and analytically continuing to real frequencies we obtain for the real part $\sigma' = \sigma'_{\text{sing}} + \sigma'_{\text{reg}}$ of the complex dynamic conductivity (the imaginary part σ'' can be obtained via the standard dispersion relation)

$$\begin{aligned} \sigma'_{\text{sing}}(\omega) &= \delta\left(\frac{\omega}{\omega_c}\right) \cdot \frac{\beta \omega_c}{R_Q} \left(\frac{\pi}{\delta}\right)^2 \int_{-\infty}^{+\infty} dx \eta(x) \\ &\quad \times \frac{\text{cosech}^2\left(\frac{\beta \omega_c}{4} \sqrt{1 - \frac{x-3}{\delta}}\right)}{1 - \frac{x-3}{\delta}}, \\ \sigma'_{\text{reg}}(\omega) &= \frac{1}{R_Q} \frac{\pi^2}{4\delta} \left(\frac{\omega_c}{\omega}\right)^2 \eta\left[3 + \delta\left(1 - \frac{\omega^2}{\omega_c^2}\right)\right] \\ &\quad \times \coth\left(\frac{\beta|\omega|}{4}\right), \end{aligned} \quad (14)$$

where $\eta(x) \equiv E_J \bar{\rho}(E_J x)$ and the parameter $\delta = \delta_\lambda/E_J$ measures the distance from the critical point with $\delta_\lambda = \lambda_0 - \lambda_0^{\text{crit}}$, and with $\omega_c = \sqrt{32E_C \delta_\lambda}$ the threshold frequency for particle-hole excitations.

The real part of the conductivity contains two contributions: first, the Drude weight $\sigma'_{\text{sing}}(\omega)$ is singular since it is proportional to $\delta(\omega)$ and the regular finite-frequency contribution to the conductivity, $\sigma'_{\text{reg}}(\omega)$, which is due to the electromagnetic field induced transitions to excited states. The singular part in turn is due to the free charge acceleration. This is so since the JJA model considered here contains no dissipation mechanism which would arise, e.g., in the presence of disorder or from a coupling of the phase degrees of freedom to normal electrons (Ohmic damping). The results of the numerical calculation for the regular part of the conductivity are shown in Fig. 3.

At $T = 0$ the singular part vanishes while the regular part can be evaluated explicitly close to the critical point with the result

$$\begin{aligned} \sigma'_{\text{reg}}(\omega, \delta \rightarrow 0) &= \frac{1}{12} \frac{1}{R_Q} \delta^{1/2} \frac{|\omega|}{\omega_c} \left(1 - \frac{\omega_c^2}{\omega^2}\right)^{3/2} \\ &\quad \times \Theta\left(\left|\frac{\omega}{\omega_c}\right| - 1\right). \end{aligned} \quad (15)$$

Note that at the $T = 0$ transition, where the gap in the response function vanishes ($\delta = 0$), there is no universal dc conductivity as in the two-dimensional case [18]. Universality emerges, however, in a different context. We will now present the scaling analysis satisfied by $\sigma(\omega)$ in the vicinity of the quantum phase transition $E_J = E_J^{\text{crit}}$,

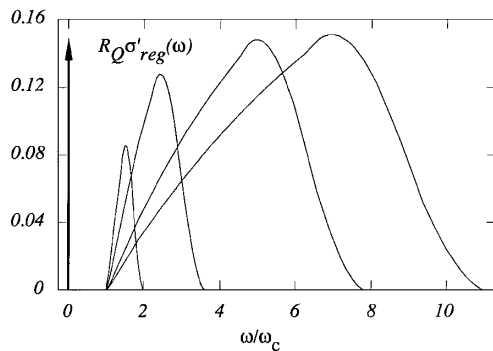

FIG. 3. Real part of the dynamical conductivity at $T = 0$, for several values of the dimensionless gap parameter δ , that measures the distance from the critical point: $\delta = 2$, $\delta = 0.5$, $\delta = 0.1$, and $\delta = 0.05$ (from the left to right). The arrow indicates the position of the singular Drude part (vanishing for $T = 0$).

where the temperature obeys $0 < k_B T \ll E_J$. The behavior of the conductivity in this regime can be understood in terms of a universal scaling function that depends on a variable which measures the distance of the superconducting ground state from criticality. In the quantum critical region we write the spherical constraint (8) in terms of a low-temperature expansion

$$1 = \int_{-\infty}^{+\infty} \eta(x) \frac{\sqrt{2\alpha}}{\sqrt{\delta + 3 - x}} + \frac{2\delta^{1/2}}{\pi^{3/2}\beta E_J} \sum_{\ell=1}^{\infty} \frac{1}{\ell} K_1\left(2\ell\beta E_J \sqrt{\frac{2\delta\alpha}{\pi}}\right), \quad (16)$$

where $K_1(x)$ is the MacDonald function [16] (i.e., second modified Bessel function) and $\alpha = E_C/E_J$. Solving Eq. (16) for small parameter δ we obtain

$$\sigma'_{\text{reg}}(\omega) = \frac{1}{12} \frac{1}{R_Q \sqrt{\alpha c}} \frac{k_B T}{E_J} F\left(\frac{\omega}{k_B T}\right). \quad (17)$$

The temperature $k_B T$ sets also the energy scale to measure the frequency via the ratio $\omega/k_B T$. It is therefore reasonable to introduce the dimensionless scaling variable $X = \omega/k_B T$ and finally explicitly write the F function as

$$F(X) = \frac{1}{4\sqrt{2}} X \left(1 - 4\sqrt{\frac{\pi}{3c_2}} \frac{1}{X^2}\right)^{3/2} \coth(X), \quad (18)$$

where $c_2 = \int_{-\infty}^{+\infty} dx \eta(x)/(3-x)^{3/2}$. At criticality the power-law behavior of the model can be deduced from Eq. (8) by taking the momentum long wavelength limit. By generalizing the analysis to d -spatial dimensions we find that the dynamical critical exponent $z = 1$, and that the correlation length exponent $\nu = 1/(d-1)$, for $d < d_u = 3$, about the $T = 0$ quantum critical point. At finite temperatures, close to the quantum phase transition we obtain $z = 1$ and $\nu = 1/(d-2)$, below the upper critical

dimension $d_u = 4$, respectively (the anomalous dimension is in turn $\eta = 0$ for all values of d).

In conclusion, we have studied a 3D quantum Josephson junction array model in the nonperturbative quantum-spherical model approximation. We have explicitly calculated the phase diagram at zero temperature as well as the conductivity and its scaling properties at low temperatures about the quantum critical point. There are several problems left to consider in the future, like the role of disorder, dissipation, and applied magnetic fields, as well as the impact of anisotropy (relevant for layered high-temperature superconductors).

This work has been partially supported by a NATO Collaborative Research Grant No. OTR.CRG 970299, by the Polish Science Committee (KBN) under Grant No. 2P03B-02415, and by NSF Grant No. DMR-9521845.

- [1] See, for example, K. Damle and S. Sachdev, Phys. Rev. B **56**, 8714 (1997).
- [2] C. Rojas and J. V. José, Phys. Rev. B **54**, 12 361 (1996).
- [3] For example, A. Goldman and N. Marković, Phys. Today **51**, No. 11, 39 (1998), and references therein.
- [4] L. L. Sohn, J. Romijn, and E. van der Drift, Physica (Amsterdam) **194/196B**, 25 (1994); C. Baraduc and J. E. Mooij, in *Proceedings of the 21st International Conference on Low Temperature Physics, Prague, Czech Republic, IUPAP* [Czech. J. Phys. **46**, Suppl. pt. S2, 705 (1996)].
- [5] M. B. Salamon, J. Shi, N. Overend, and M. A. Howson, Phys. Rev. B **47**, 5520 (1993).
- [6] F. Gibbons, A. Góngora-T., and J. V. José, Phys. Rev. B **58**, 982 (1998).
- [7] M. V. Simkin, Phys. Rev. B **44**, 7074 (1991).
- [8] S. Kim and M. Y. Choi, Phys. Rev. B **41**, 111 (1990).
- [9] A. D. Zaikin, J. Low Temp. Phys. **80**, 223 (1990).
- [10] E. Simanek, Phys. Rev. B **32**, 500 (1985); *Inhomogeneous Superconductors* (Oxford University Press, New York, 1994).
- [11] D. Das and S. Doniach, Phys. Rev. B **60**, 1261 (1999).
- [12] H. Kleinert, *Path Integrals in Quantum Mechanics, Statistics and Polymer Physics* (World Scientific, Singapore, 1990).
- [13] T. Vojta, Phys. Rev. B **53**, 710 (1996).
- [14] T. K. Kopeć and J. V. José, Phys. Rev. B **60**, 7473 (1999).
- [15] C. Bruder *et al.*, Phys. Scr. **42**, 139 (1992).
- [16] M. Abramowitz and I. A. Stegun, *Handbook of Mathematical Functions* (Dover, New York, 1964).
- [17] G. S. Joyce, in *Phase Transitions and Critical Phenomena*, edited by C. Domb and M. S. Green (Academic, New York, 1972), Vol. 2, p. 375.
- [18] M.-C. Cha *et al.*, Phys. Rev. B **44**, 6883 (1991). The M -vector model in the $M \rightarrow \infty$ limit used for evaluation of σ at $d = 2$ by the above authors and the spherical approach employed here have much in common (see, e.g., Ref. [17]). However, by considering the full lattice model we do not restrict ourselves exclusively to the vicinity of the critical point as in the work of M.-C. Cha *et al.*
- [19] A. van Otterlo *et al.*, Phys. Rev. B **48**, 3316 (1993).
- [20] R. Fazio and D. Zappala, Phys. Rev. B **53**, R8883 (1996).