

Multiple Andreev Reflections and Enhanced Shot Noise in Diffusive Superconducting-Normal-Superconductor Junctions

E. V. Bezuglyi,^{1,2} E. N. Bratus',^{1,2} V. S. Shumeiko,² and G. Wendin²

¹*B. Verkin Institute for Low Temperature Physics and Engineering, Kharkov, Ukraine*

²*Chalmers University of Technology and Göteborg University, 41296 Göteborg, Sweden*

(Received 22 January 1999)

We study the dc conductance and current fluctuations in mesoscopic diffusive SNS junctions at subgap applied voltages $eV < 2\Delta$. We find that in spite of the multiple Andreev reflections, the current-voltage characteristic of a long SNINS structure obeys Ohm's law. At the same time, non-equilibrium heating of subgap electrons produces giant shot noise with pronounced subharmonic gap structure which corresponds to stepwise growth of the effective transferred charge. At $eV \rightarrow 0$, the shot noise approaches the magnitude of the Johnson-Nyquist noise with the effective temperature $T^* = \Delta/3$. We analyze the role of inelastic scattering and present a criterion of strong nonequilibrium.

PACS numbers: 74.50.+r, 74.20.Fg, 74.80.Fp

Current transport through mesoscopic resistive elements (tunnel barriers and disordered normal conductors) attached to superconductors is a subject of permanent interest and intensive experimental studies. The investigations of superconducting junctions are primarily focused on the complex nonlinear behavior of current-voltage characteristics, which exhibit subharmonic gap structure, zero bias anomaly, etc. In this Letter, we will discuss an elementary mesoscopic superconducting structure where the current shot noise manifests anomalous transport properties while the average current shows perfect Ohmic behavior.

The circuit under discussion consists of a low-transmission tunnel junction (or point contact) connected to voltage biased superconducting reservoirs via diffusive normal leads (Fig. 1a), like, e.g., a short-gate Josephson field effect transistor [1]. In a normal-insulator-normal (NIN) structure connected to normal reservoirs, the average current obeys Ohm's law and the current fluctuations show full Poissonian shot noise, $S = 2eI$, if the tunnel resistance R dominates over the resistance of the normal leads [2]. The effect of the superconducting reservoirs, which has recently attracted much attention, is to modify the density of states and to create a gap E_g in the electron spectrum of the normal leads [3]. This proximity effect provides dc Josephson current flow and, simultaneously, blocks the single-particle tunneling at applied voltages $eV < 2E_g$. At these subgap voltages, the current is due to multiparticle tunneling (MPT) [4]. The MPT regime is manifested by the stepwise decrease of the current with decreasing applied voltage (subharmonic gap structure at $eV = 2E_g/n$), which provides exponential decay of the current [5]. At the same time, the current shot noise undergoes enhancement due to the growth of the elementary tunneling charge ne [6]. MPT has been extensively studied theoretically in quantum point contacts [5,7], and in short diffusive constrictions [8] with a wide proximity gap of the order of the energy gap Δ in the superconducting reservoirs. Both the subharmonic gap

structure and the enhanced shot noise have been observed experimentally [9,10].

A distinctly different transport regime occurs in long diffusive superconductor-normal-superconductor (SNS) junctions with a small proximity gap of the order of

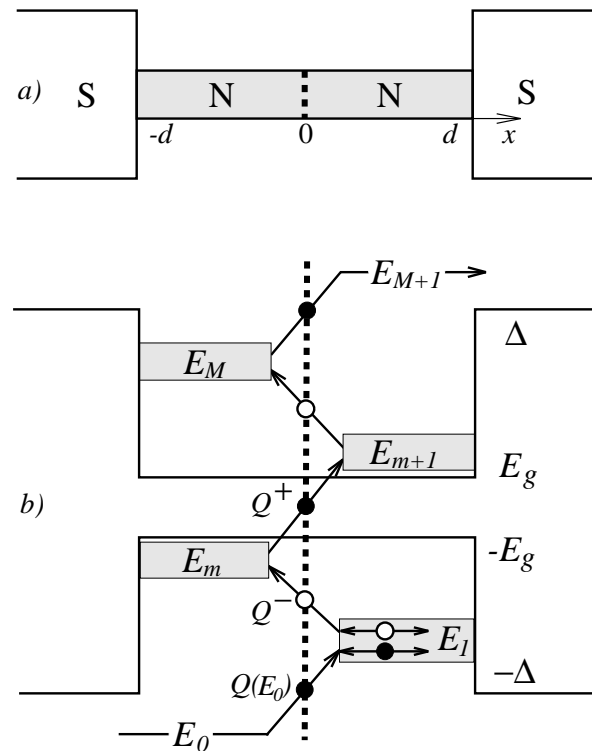

FIG. 1. (a) Diffusive mesoscopic junction with a tunnel barrier at $x = 0$ (dashed line). (b) Schematic picture of incoherent MAR. An equilibrium electron incoming from the superconducting reservoir consequently tunnels through M Andreev side bands and creates elementary probability current Q flowing along the energy axis between the equilibrium regions outside the gap. Each crossing of the barrier is associated with the transfer of the elementary charge e , and the electric current is $eQ(M + 1)$.

the Thouless energy, $E_g \sim E_{\text{Th}} \ll \Delta$. In this case, the Josephson current is suppressed, and single-particle tunneling dominates at virtually all applied voltages, $E_{\text{Th}} \ll eV < 2\Delta$. However, when the inelastic mean free path exceeds the distance between the superconducting reservoirs, current transport at subgap voltages $eV < 2\Delta$ is still nontrivial: the tunneling electrons must undergo multiple Andreev reflections (MAR) before they enter the reservoirs [11]. We will show that in long SNS structures with opaque tunnel barriers, the current-voltage characteristic is perfectly linear and structureless, while the current shot noise is greatly enhanced and reveals subharmonic gap structure (kinks) at voltages $eV = 2\Delta/n$ (incoherent MAR regime).

The origin of the linear current-voltage dependence and the significant deviation of tunnel shot noise from the Poisson law can be qualitatively explained in the following way. In order to overcome the energy gap at low voltages ($eV \ll 2\Delta$) the electron has to undergo a large number ($M \approx 2\Delta/eV$) of Andreev reflections, gaining the energy eV in each passage of the tunnel barrier (Fig. 1b). Thus, MAR tunneling in real space is associated with probability current flow along the energy axis through a structure of $M + 1$ tunnel barriers with the total effective resistance $R_M = (M + 1)R$. Since only electrons incoming within the energy layer eV below the gap 2Δ participate in MAR transport, the total probability current is $I_p = V/R_M$. However, each pair of consecutive Andreev reflections transfers the charge $2e$ through the junction, and the real current I is therefore $M + 1$ times greater than the probability current: $I = (M + 1)I_p = V/R$. The current flow in energy space generates shot noise S_p which is related to the probability current as $S_p = (2/3)eI_p$ in the limit $M \rightarrow \infty$. The arguments for the $1/3$ suppression of the Poissonian noise in multibarrier tunnel structures are similar to the ones presented in Ref. [2]. Since the noise spectral density is given by the current-current correlation function, the real shot noise S is $(M + 1)^2$ times greater than S_p , i.e., approaches a constant value $S = (4/R)(\Delta/3)$. This coincides with the exact result, Eqs. (9) and (10) below, in the limit $eV \rightarrow 0$.

For a quantitative treatment of incoherent MAR, we consider the diffusive kinetic equation [12] for the 4×4 supermatrix Keldysh-Green's function $\check{G}(x, t_1, t_2)$

$$i\nabla\check{J} = [\check{H}, \check{G}], \quad \check{G}^2 = \check{1}, \quad \check{J} = \mathcal{D}\check{G}\nabla\check{G}, \quad (1)$$

where \mathcal{D} is the diffusion constant. We apply Eqs. (1) to the electrons in the normal leads and match the Green's functions at the tunnel barrier ($x = \pm 0$) of low transparency ($\Gamma \ll 1$) using the boundary condition [13]

$$\check{J}(-0) = \check{J}(+0) = (j/2)[\check{G}(-0), \check{G}(+0)], \quad (2)$$

$$j = (1/2)v_F\Gamma.$$

Equation (2) represents the conservation law for the supermatrix current \check{J} and connects it with the voltage-induced imbalance of elementary probability currents j

of tunneling electrons. Since we have assumed that the barrier resistance R dominates over the resistance R_d of the leads ($R \gg R_d$), the voltage drop at the barrier determines the time-dependent phase difference between the reservoirs by virtue of the Josephson relation. A gauge transformation allows us to remove the time dependence in the Hamiltonian in Eq. (1) and cancel the electric potential. Simultaneously, a periodic time dependence appears in the boundary condition of Eq. (2), which implies that the Green's function $\check{G}(x, t_1, t_2)$ consists of a set of harmonics $\check{G}(x, E_n, E_m)$, $E_n = E + neV$. The problem is solvable in the limit of weak Josephson coupling, $\Gamma \ll 1$ and/or $E_{\text{Th}} \ll \Delta$, when off-diagonal Green's function harmonics can be neglected and the diagonal harmonics ($n = m$) satisfy the static equations, similar to the case of zero applied voltage.

The dc current I can be expressed, to first order in Γ , through the quasiparticle distribution function $f(E)$ defined by the following representation of the Keldysh function: $\hat{g}^K = \hat{g}^R\hat{f} - \hat{f}\hat{g}^A$, $\hat{f} = \hat{1}(1 - f) + \sigma_z f_z$, where $\hat{g}^{R,A}$ are the retarded (advanced) Green's functions, giving

$$I = \frac{1}{2eR} \int_{-\infty}^{+\infty} dE N(E)N(E_1)[f(E) - f(E_1)]. \quad (3)$$

The density of states, $N(E) = (1/4)\text{Tr}\sigma_z(\hat{g}^R - \hat{g}^A)$, is calculated for a nontransparent barrier and normalized by the normal-electron density of states; all values are taken at the interface, $x = 0$. Equation (3) has the same form as the conventional equation of the tunnel model [14], with the nonequilibrium distribution function $f(E, x)$ obeying a kinetic equation following from Eq. (1),

$$\frac{\partial}{\partial x} D(E, x) \frac{\partial f}{\partial x} = \frac{N(E, x)}{\tau_\varepsilon} [f(E, x) - f_0(E)], \quad (4)$$

$D(E, x) = (\mathcal{D}/4)\text{Tr}(1 - \hat{g}^R\hat{g}^A)$. The inelastic scattering term in Eq. (4), describing relaxation to equilibrium population $f_0(E) = 2n_F(E)$, is written for simplicity in the relaxation time approximation. The boundary condition for the function f at the tunnel interface obtained from Eq. (2) reads

$$-D(E, x)(\partial f/\partial x)|_0 = Q^+(E) - Q^-(E), \quad (5)$$

$$Q^\pm(E) = \pm(j/2)N(E)N(E_{\pm 1})[f(E) - f(E_{\pm 1})].$$

The quantities Q^\pm , which also determine the current in Eq. (3), can be interpreted as spectral quasiparticle currents, i.e., probability currents flowing upwards in energy space (Fig. 1): the current Q^+ exits from energy E towards energy $E + eV$, while the current Q^- arrives at energy E from energy $E - eV$. Along this line of reasoning, the boundary condition, Eq. (5), represents the detailed balance between the spectral quasiparticle current and the leakage current [the term on the left-hand side of Eq. (5)] due to either inelastic relaxation or escape into the reservoirs.

Let us consider the limit of infinitely large inelastic relaxation time [15]. In this case, the leakage current is

spatially homogeneous according to Eq. (4). Within the energy gap, $|E| < \Delta$, the diffusion coefficient $D(E, x)$ turns to zero in the superconducting reservoirs, and therefore the leakage current is blocked, indicating complete Andreev reflection. Thus, the spectral current Q^\pm is conserved within the superconducting gap: $Q^+ = Q^-$. This equation provides recurrence relations for the nonequilibrium distribution functions $f(E_n)$ in different sidebands associated with MAR. The boundary conditions are established by the requirement of equilibrium outside the gap, $f(E_n) = 2n_F(E_n)$, $|E_n| > \Delta$. Indeed, the reservoirs maintain the equilibrium at the NS boundaries, $f(E, \pm d) = 2n_F(E)$; on the other hand, the gradient of the distribution function given by Eq. (5) is small, $\sim R_d/R \ll 1$, and may be neglected. We note that the latter condition is equivalent to a small ratio between the diffusion time through the normal lead, $d^2/\mathcal{D} = E_{Th}^{-1}$, and the inverse tunneling rate, $(\Gamma v_F/d)^{-1}$, i.e., $\Gamma v_F/d \ll E_{Th} \ll \Delta$.

The physical picture of MAR in diffusive SNINS systems is illustrated in Fig. 1b. The equilibrium electron-like quasiparticles incoming from the left electrode with energy $-\Delta - eV < E_0 < -\Delta$ create a probability current $Q^1(E_0) = j n_F(E_0) N(E_0) N(E_0 + eV)$ across the tunnel junction into the subgap region. Because of low transmissivity of the barrier and fast electron diffusion through the normal leads, the particle undergoes many Andreev reflections from the superconductor before the next tunneling event will occur and, therefore, the electron and hole states at energy $E_1 = E_0 + eV$ are occupied with equal probability $(1/2)f(E_1)$ [16]. Thus, the population $f(E_1)$ produces both the current of holes $Q^1(E_1) = (j/2)f(E_1)N(E_1)N(E_2)$ moving upwards along the energy axis to the next side band, and the countercurrent of electrons $Q^1(E_1) = (j/2)f(E_1)N(E_0)N(E_1)$ down to the initial state, determining the net probability current $Q(E_0) = Q^1(E_0) - Q^1(E_1)$, and so on. As a result, the electron tunneling in real space is associated with the flow of spectral current $Q^+(E_m) = Q^-(E_m) = Q(E_0)$ through $M + 1$ tunnel barriers connected in series by a number $M(E_0) = \text{Int}[(\Delta - E_0)/eV]$ of Andreev side bands ($\text{Int}[x]$ denotes the integer part of x). In this transport problem in energy space, there is an effective bias voltage $(M + 1)eV$ drop between the reservoirs represented by the spectral regions outside the energy gap, $|E| > \Delta$, and it is equally distributed among the barriers. Therefore, the distribution function has a steplike form,

$$f(E_m) = 2 \left[[n_F(E_{M+1}) - n_F(E_0)] \frac{Z_m}{Z_{M+1}} + n_F(E_0) \right], \quad (6)$$

$$Z_m(E_0) = \sum_{k=0}^{m-1} N^{-1}(E_k) N^{-1}(E_{k+1}), \quad Z_0 = 0. \quad (7)$$

The tunnel current in Eq. (3) is determined by the spectral current Q^+ . At low temperature, the equilibrium spectral current at $|E| > \Delta$ is exponentially small, and the main contribution to the total current comes from the nonequilibrium subgap region. Dividing it into pieces

of length eV and taking into account spectral current conservation, one finds from Eqs. (3) and (6)

$$I(V) = \frac{1}{eR} \int_{-\Delta-eV}^{-\Delta} dE_0 \frac{M+1}{Z_{M+1}} [n_F(E_0) - n_F(E_{M+1})]. \quad (8)$$

Equation (8) describes the single-particle current in a tunnel junction of arbitrary length. If some MAR chain contains a sideband E_n within the proximity-induced gap $2E_g$, the corresponding density of states $N(E_n)$ is zero, and the spectral current associated with this chain is blocked. At $eV < 2E_g$, any MAR chain has at least one side band within the gap, and the total single particle current in Eq. (8) vanishes. In the limit of a long junction, the proximity gap closes and the local density of states becomes constant, $N(E) = 1$. In this case, the current in Eq. (8) shows Ohmic behavior, $I = V/R$, with the same resistance R as in the absence of superconducting "mirrors."

Let us turn to the calculation of the tunnel current shot noise power $S(V)$. A general quantum equation for the shot noise in superconducting junctions has been derived in [17]. Assuming the asymptotic limit of a highly resistive tunnel barrier and the long-junction approximation we write it in the form

$$S(V) = \int_{-\infty}^{+\infty} \frac{dE}{R} [f(E) + f(E_1) - f(E)f(E_1)]. \quad (9)$$

Taking into account the distribution function in Eq. (6), the noise power at zero temperature becomes

$$S(V) = \frac{2}{R} \int_{-\Delta-eV}^{-\Delta} \frac{dE}{3} \left[M(E) + 1 + \frac{2}{M(E) + 1} \right].$$

At voltages $eV > 2\Delta$ this formula gives conventional Poissonian noise $S = 2eI$. At subgap voltages, the noise power undergoes enhancement: it shows a piecewise linear voltage dependence, $dS/dV = (2e/3R)[1 + 4/(\text{Int}[2\Delta/eV] + 2)]$, with kinks at the subharmonics of the superconducting gap, $eV_n = 2\Delta/n$ (see Fig. 2). At zero voltage, the noise power approaches the constant value $S(0) = (4/R)(\Delta/3)$, which corresponds to the thermal Johnson-Nyquist noise with the effective temperature $T^* = \Delta/3$.

The enhancement of the shot noise power can be alternatively interpreted as an increase of the effective charge $q(V) = S(V)/2I$ with decreasing voltage,

$$\frac{q(V_n)}{e} = \frac{1}{3} \left(n + 1 + \frac{2}{n + 1} \right) = 1, \frac{11}{9}, \frac{22}{15}, \dots \quad (10)$$

In the limit $eV \rightarrow 0$ the effective charge increases as $q(V)/e \approx (1/3)(1 + 2\Delta/eV)$. This result differs by a factor 1/3 from the value expected from a straightforward MAR argument which assumes the shot noise to be equal to the Poisson noise enhanced by the factor M . We stress that the 1/3 factor here results from multiple traversal of

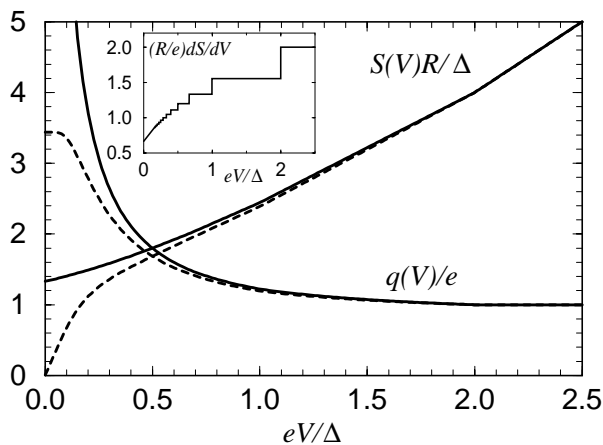

FIG. 2. Spectral density $S(V)$ of current shot noise and effective transferred charge $q(V) = S(V)/2I$ as functions of applied voltage V . In the absence of inelastic collisions (solid lines), the shot noise power approaches the finite value $S(0) = (4/R)(\Delta/3)$ at $eV \rightarrow 0$, and the effective charge increases as $q(V) = (e/3)(1 + 2\Delta/eV)$. The effect of inelastic scattering is represented by dashed lines for the nonequilibrium parameter $W_\varepsilon = 5$. The dependence $S(V)$ contains kinks at the gap subharmonics, $eV = 2\Delta/n$, as shown in the inset.

the tunnel barrier due to incoherent MAR and has nothing to do with the diffusive normal leads.

A more detailed analysis with account of inelastic scattering shows that the current shot noise is suppressed at low voltage when the lifetime of a quasiparticle within the normal leads becomes comparable to the inelastic relaxation time [$\alpha \geq 1$; see Eq. (11)]. Generalized recurrences for the distribution function in long junctions [$N(E) = 1$] then take the form [18]

$$f(E) - f_0(E) = W_\varepsilon [f(E_1) + f(E_{-1}) - 2f(E)].$$

The level of nonequilibrium of the subgap electrons is controlled by the parameter $W_\varepsilon = (R_d/R)(E_{Th}\tau_\varepsilon/4)$. The strong nonequilibrium state discussed above is possible only at $W_\varepsilon \geq 1$ whereas in the opposite limit, $W_\varepsilon \ll 1$, the normal leads may always be considered as reservoirs, and the enhanced noise disappears.

Numerical results for $W_\varepsilon = 5$ are presented in Fig. 2 by dashed curves. The rapid decrease of $S(V)$ at low voltage described by the following analytical approximation,

$$S(V) = S(0) \frac{3}{\alpha} \left(\tanh \frac{\alpha}{2} + \frac{\alpha - \sinh \alpha}{\sinh^2 \alpha} \right), \quad \alpha = \frac{\Delta}{eV\sqrt{W_\varepsilon}}, \quad (11)$$

occurs when the length of the MAR chain interrupted by inelastic scattering, $eV\sqrt{W_\varepsilon}$, becomes less than 2Δ .

In conclusion, we have studied subgap tunnel current and current shot noise in diffusive SNINS structures. We found that in junctions with normal leads which are much longer than the coherence length but much shorter than inelastic mean free path, the strongly nonequilibrium dis-

tribution of the subgap electrons created by MAR is manifested in the shot noise rather than in the tunnel current. While the tunnel current obeys Ohm's law, the current shot noise is significantly enhanced and shows subharmonic gap structure. This conclusion is also valid for junctions where the tunnel barrier is replaced by a point contact or locally suppressed diffusion constant; moreover, the properties of incoherent MAR are qualitatively similar in homogeneous SNS junctions where the normal resistance exceeds the resistance of NS interfaces.

Support from KVA, NFR, and NUTEK (Sweden), and from NEDO (Japan) is gratefully acknowledged.

- [1] H. Takayanagi *et al.*, Appl. Phys. Lett. **68**, 418 (1996).
- [2] M.J.M. de Jong and C.W.J. Beenakker, Physica (Amsterdam) **230A**, 219 (1996).
- [3] A. A. Golubov and M. Yu. Kupriyanov, Sov. Phys. JETP **69**, 805 (1989); W. Belzig, C. Bruder, and G. Schön, Phys. Rev. B **54**, 9443 (1996); S. Gueron *et al.*, Phys. Rev. Lett. **77**, 3025 (1996).
- [4] J.R. Schrieffer and J.W. Wilkins, Phys. Rev. Lett. **10**, 17 (1963).
- [5] E.N. Bratus', V.S. Shumeiko, and G. Wendin, Phys. Rev. Lett. **74**, 2110 (1995); Low Temp. Phys. **23**, 249 (1997).
- [6] D. Averin and H.T. Imam, Phys. Rev. Lett. **76**, 3814 (1996).
- [7] D. Averin and A. Bardas, Phys. Rev. Lett. **75**, 1831 (1995); E.N. Bratus' *et al.*, Phys. Rev. B **55**, 12 666 (1997); J.C. Cuevas *et al.*, Phys. Rev. B **54**, 7366 (1996).
- [8] A. Bardas and D. Averin, Phys. Rev. B **56**, R8518 (1997); A.V. Zaitsev and D. Averin, Phys. Rev. Lett. **80**, 3602 (1998).
- [9] N. van der Post *et al.*, Phys. Rev. Lett. **73**, 2611 (1994); E. Scheer *et al.*, Phys. Rev. Lett. **78**, 3535 (1997).
- [10] P. Dieleman *et al.*, Phys. Rev. Lett. **79**, 3486 (1997); T. Hoss *et al.*, cond-mat/9901129.
- [11] T.M. Klapwijk, G.E. Blonder, and M. Tinkham, Physica (Amsterdam) **109-110B+C**, 1657 (1982); M. Octavio *et al.*, Phys. Rev. B **27**, 6739 (1983).
- [12] A.I. Larkin and Yu.N. Ovchinnikov, Sov. Phys. JETP **41**, 960 (1975); **46**, 155 (1977).
- [13] M. Yu. Kupriyanov and V.F. Lukichev, Sov. Phys. JETP **67**, 1163 (1988).
- [14] M.H. Cohen, L.H. Falicov, and J.C. Phillips, Phys. Rev. Lett. **8**, 316 (1962).
- [15] More precisely, τ_ε is to be much larger than the quasiparticle lifetime within the normal leads; see Eq. (11).
- [16] The equality of electron and hole numbers reflects the absence of an f_z component of the matrix distribution function \hat{f} , which assumes the electric field within the normal leads to be negligibly small.
- [17] A.I. Larkin and Yu.N. Ovchinnikov, Sov. Phys. JETP **60**, 1060 (1984); V.A. Khlus, *ibid.* **66**, 1243 (1987).
- [18] This equation is obtained from the kinetic equation (4) by integrating over the length d of the normal lead; the assumption of small spatial variations of the distribution function allows us to replace $f(E, x)$ by its boundary value $f(E)$ in the collision integral.