

PHYSICAL REVIEW LETTERS

VOLUME 81

20 JULY 1998

NUMBER 3

Separated-Path Ramsey Atom Interferometer

P. D. Featonby, G. S. Summy, C. L. Webb, R. M. Godun, M. K. Oberthaler, A. C. Wilson, C. J. Foot, and K. Burnett
Clarendon Laboratory, Department of Physics, University of Oxford, Parks Road, Oxford, OX1 3PU, United Kingdom
(Received 12 March 1998)

We demonstrate a novel type of cesium atom interferometer which uses a combination of a microwave ground state transition and momentum changing adiabatic transfer light pulses as the atom optical components. It is the first atom interferometer where the mechanism which forms the internal superposition plays no part in spatially splitting the atomic wave packets. The coherence length of the atom source is found by measuring the spatial correlation between the two interferometer arms. This allows us to determine the temperature of the atomic ensemble. [S0031-9007(98)06643-5]

PACS numbers: 03.75.Dg, 32.80.Lg, 39.20.+q, 42.50.Vk

In the past few years atomic matter wave interferometry has become a valuable tool for probing processes such as accelerations, scattering amplitudes, and fundamental quantum phenomena [1]. These experiments work by forming a closed loop interferometer in which a wave packet is coherently split into two paths which eventually overlap so that interference can occur.

In this Letter we present results from an atomic interferometer of a unique design in which the internal and external states of a cesium atom are manipulated separately to produce such a closed loop. The foundation of our experiment is the well-known Ramsey interferometer [2] shown in Fig. 1(a). This consists of two separated oscillatory field interactions which create superpositions of the internal states. To observe the interference fringes we change the phase of the final interaction so that the accumulated phase difference between the internal states is transformed into a difference in population. The fringes from such an experiment can be seen in Fig. 2(a). The closed loop Mach-Zehnder-type interferometer, shown in Fig. 1(b), is created by taking the basic Ramsey configuration and manipulating the external state of each internal superposition component in turn. This is done in a way such that the two internal states have the same final external state and can be recombined. Results from this experiment are shown in Fig. 2(b), where the population of one internal state is plotted as a function of the phase of the last interaction which internally manipu-

lates the atom. Experimentally, the separated oscillatory fields are produced by microwaves and the external state (atomic momentum) is controlled using adiabatic transfer (AT) light pulses. Figure 3 shows the sequence of interactions used to create the interferometer. This scheme has the advantage that the mechanism forming the coherent superposition and the process splitting the paths are independent. This facilitates a greater amount of experimental control.

We performed an experiment to examine the dependence of the interference fringe visibility and phase on the final spatial overlap of the wave functions in the two arms. A major feature of this experiment was the reduction in visibility as the separation between the output wave functions was increased. Measuring the loss of visibility allowed us to extract the spatial correlation function and from this the one-dimensional temperature of the atomic ensemble in the direction of the interferometer arm separation. Temperature measurements using an alternative approach for determining the spatial correlation function have also been recently reported by Saubaméa *et al.* [3].

The use of AT in atom optics has been described by a number of different authors [4]. The essence of the method is to use a light field configuration for which a particular superposition of the atomic ground states cannot couple to the excited state. If the light field is changed adiabatically [5], an atom which is initially decoupled remains decoupled by adjusting its ground state

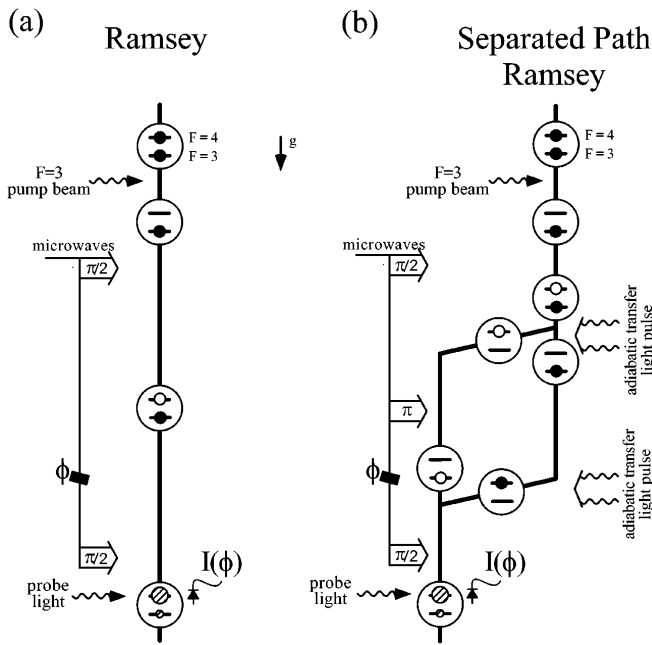

FIG. 1. Experimental configurations used to observe interference, with open and solid circles tracing the dynamics of the atomic population. The hashed circles at the output represent the uncertainty in determining which path the population has taken. In (a) we see the sequence of microwave $\frac{\pi}{2}$ pulses used for the Ramsey scheme. The setup for the separated path interferometer can be seen in (b). The main difference between these two experiments was the introduction of two AT pulses to separate the wave packets. Since AT light could only interact with atoms in the $F = 4$ level, an additional π microwave pulse was also applied to make the separated-path interferometer symmetric. The width and length of this interferometer was approximately 1 and 40 μm , respectively.

configuration according to the state of the field. When the atom is in this “dark” state, spontaneous emission is suppressed and the coherence of the atom is preserved.

Our dark state scheme involves orthogonally propagating light fields of linear (π) and circular (σ^+) polarizations which are resonant with the D_1 $6S_{1/2}, F = 4 \rightarrow 6P_{1/2}, F' = 4$ transition. With this configuration the ground state population can be transferred from $F = 4, m = 0$ to $F = 4, m = +4$. If the population is initially in $F = 4, m = 0$, all of the light must start in the linearly polarized beam for the atom to be dark. After all of the intensity has been slowly transferred into the circularly polarized beam the atom is found in the $m = 4$ state. The atom is dark at the start and finish of this interaction by the dipole selection rules alone. At intermediate times the atom is in a superposition of the magnetic substates between $m = 0$ and $m = 4$ which is dark because of the destructive interference of the excitation amplitudes from the substates.

Since this process is coherent, the atom absorbs four photons from the σ^+ beam and emits four photons into the π beam, producing a total momentum change of $4\sqrt{2} \hbar k$.

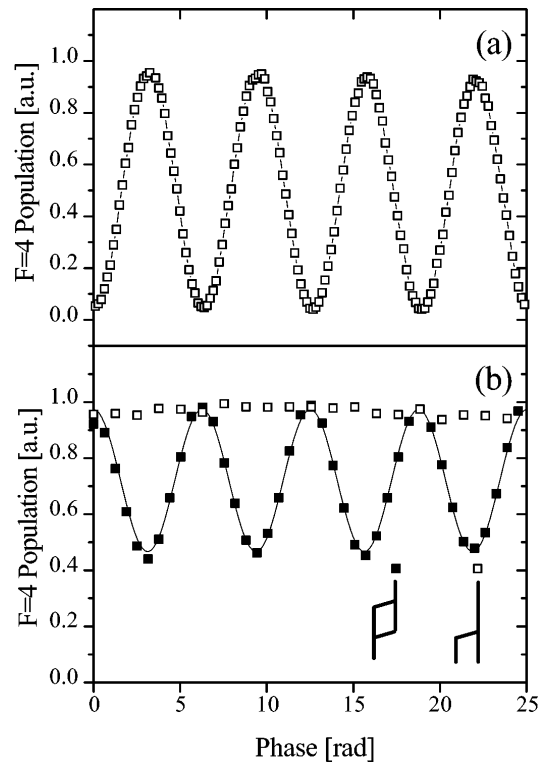

FIG. 2. Fringes from (a) Ramsey (visibility 95%) and (b) separated path interferometers (visibility 35%). The final population of the $F = 4$ state is plotted against the phase of the last $\frac{\pi}{2}$ microwave pulse. In (b), the \blacksquare represents data obtained using two AT pulses (large final spatial overlap) and the \square shows results with only the second AT pulse (no final spatial overlap). The solid line is a sinusoidal fit to the data. Error bars are of the same order as the point size.

It is undesirable to leave the atomic population in $m = 4$ because magnetic fields may introduce unwanted phase shifts. Thus, once $m = 4$ is reached, the AT is reversed in time so that the population is returned to $m = 0$. Although the net momentum transfer of such a process is zero,

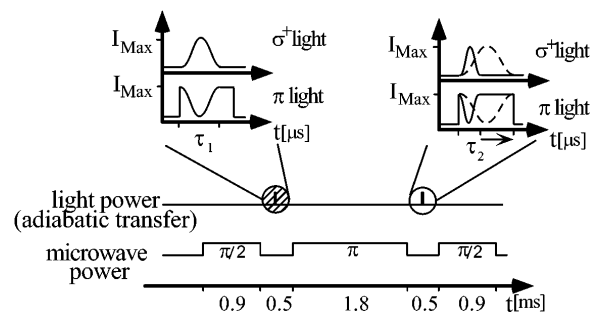

FIG. 3. Sequence of events for the separated path experiment starting from the application of the first microwave pulse. The Ramsey interferometer was realized by only performing the two $\frac{\pi}{2}$ microwave pulses. The final spatial overlap was varied by changing the duration of the last AT process τ_2 , while the first AT length τ_1 was kept constant. The hashed AT pulse could also be omitted, as was done in the \square data of Fig. 2(b).

a small displacement is produced because of the finite momentum of the atom during the pulse. With this “out and back” sequence it is possible to realize displacements of approximately $1 \mu\text{m}$ in a pulse time of $100 \mu\text{s}$. This technique can be extended to a method for beam splitting into two paths by initially creating a superposition of the $m = 0$ components of the $F = 3$ and $F = 4$ ground levels with a $\frac{\pi}{2}$ pulse of microwaves. The momentum of the $F = 4$ component of the superposition can then be manipulated with the $\pi - \sigma^+ - \pi$ AT sequence [6] so that the $F = 3$ and $F = 4$ levels spatially separate.

Our atomic source consisted of a magneto-optic trap (MOT) of approximately 10^7 atoms which was cooled in an optical molasses. The temperature of these atoms, measured with a time of flight technique, was found to be approximately $3 \mu\text{K}$. After the molasses beams were turned off, the atoms fell and were optically pumped into the $F = 3$ ground state by a pulse of resonant $F = 4 \rightarrow F' = 4$ light. The atoms then underwent the sequence of microwave and AT pulses which constituted the interferometer. The microwave source was formed by a piece of X-band waveguide with a 1 cm hole located half a wavelength from its blanked-off end. When the atoms experienced the microwaves they were approximately 2.5 cm above the waveguide hole. A weak bias field of 10 mG was applied in the z direction to set up a quantization axis for the atoms and lift the degeneracy of the Zeeman substates to allow discrimination of the various microwave transitions by frequency. Thus we could be certain of exciting only the $m = 0 \rightarrow m = 0$ transition. Light for the AT was generated by a Ti:sapphire laser locked to the $F = 4 \rightarrow F' = 4$ transition of the D_1 line at 894 nm. Each AT pulse had an efficiency of approximately 60%.

Our Ramsey fringe and separated path interferometry schemes both started with the application of a $\frac{\pi}{2}$ pulse of the microwaves to create an equal superposition of the $F = 3, m = 0$ and $F = 4, m = 0$ states. To observe the Ramsey fringes of Fig. 2(a) we applied an additional microwave pulse with a $\frac{\pi}{2}$ configuration. Ramsey fringes are normally obtained by changing the frequency of the microwave field; however, in our experiment we scanned the phase of the final $\frac{\pi}{2}$ pulse and kept the frequency constant so that our fringes were not modulated by the line shape of the microwave transition. The final signal was obtained by measuring the population of the $F = 4$ state via the absorption of probe light resonant with the $6S_{1/2}, F = 4 \rightarrow 6P_{3/2}, F' = 5$ transition.

The full interferometer shown in Fig. 1(b) was realized by modifying the Ramsey scheme so that AT was carried out immediately after the first and just before the last microwave pulse. The first AT was used to split the paths and the second reestablished the spatial overlap between the components of the superposition. After the first AT, a π pulse of microwaves was applied to swap the $F = 3$ and $F = 4$ components of the superposition.

This preserved the overall symmetry of the interferometer and also obviated the need for the second AT to be carried out with laser beams in the opposite direction. Both AT pulses were performed with the same two orthogonal laser beams which had a diameter of 2 cm and a typical intensity of $10 \text{ mW}/\text{cm}^2$. The final stage of the interferometer sequence was a $\frac{\pi}{2}$ pulse of microwaves which recombined the states of the superposition. Typical fringes from this setup can be seen in Fig. 2(b). In this figure we also show data obtained using the same experimental parameters for the AT, but with the critical difference that only the second AT pulse was applied. This separated the paths of the interferometer without having the additional reoverlapping pulse. The result of this experiment was that fringes were no longer observed. This is interpreted as being the effect of the separation between the arms becoming greater than the transverse coherence length of the source.

We now discuss a method for estimating the temperature of the atomic source based upon a measurement of its coherence length. Our probe beam detected an absorption signal S , proportional to the final population of the $F = 4$ state. This can be written as

$$S \propto \sum_{i=1}^N \int_{-\infty}^{+\infty} |\psi_i(x)|^2 dx, \quad (1)$$

where $\psi_i(x) = f_i(x) + g_i(x - a)$, and the $F = 4$ wave functions in the two arms $f_i(x)$; $g_i(x - a)$ are separated by a distance a . We have also summed over the contributions of all N atoms in our ensemble. If S_{max} and S_{min} represent the maximum and minimum values observed in an interference signal, then a general expression for the fringe visibility is

$$\mathcal{V} = \frac{S_{\text{max}} - S_{\text{min}}}{S_{\text{max}} + S_{\text{min}}}. \quad (2)$$

Using this definition, it can be shown that the visibility of the fringes formed by scanning the phase of the final microwave pulse is proportional to the sum of the spatial correlations of the wave functions found in the expansion of Eq. (1). That is,

$$\mathcal{V}(a) \propto \sum_{i=1}^N \int_{-\infty}^{+\infty} \text{Re}[f_i^*(x)g_i(x - a)] dx. \quad (3)$$

Taking the Fourier transform of Eq. (3), we obtain

$$\int_{-\infty}^{+\infty} \mathcal{V}(a)e^{-ika} da \propto \sum_{i=1}^N \text{Re}[F_i^*(k)G_i(k)], \quad (4)$$

where $F_i(k)$ and $G_i(k)$ represent the momentum distributions of the i th wave packet and are the Fourier transforms of $f_i(x)$ and $g_i(x)$. Assuming that $F_i(k)$ and $G_i(k)$ are proportional [7], the sum in Eq. (4) becomes the momentum distribution of the atomic ensemble, from which a determination of the temperature can be made.

We now discuss the experiment we performed to measure the visibility function $\mathcal{V}(a)$. To create various arm separations a , both paths of the interferometer experienced AT pulses of slightly different durations. After a single AT pulse of length τ , the expectation value of the wave function position is $\langle x \rangle = 2\sqrt{2} v_{\text{recoil}} \tau$, where v_{recoil} is the recoil velocity due to the absorption of one photon. We have assumed that during the AT pulse the atom has an average momentum of 2 and -2 photon recoils in the direction of the σ^+ and π beams, respectively [8]. If the AT pulses experienced by each arm are the same, then perfect spatial overlap at the output of the interferometer is assured. However, if the pulse lengths are slightly different, we then create a spatial separation a given by

$$a = 2\sqrt{2} v_{\text{recoil}}(\tau_2 - \tau_1), \quad (5)$$

where τ_1 and τ_2 are the durations of the first and second AT processes, respectively.

Experimentally there are two important points to consider. Firstly, the velocity selection caused by the AT should be very similar for each pulse. Secondly, the effects of light induced decoherence should remain relatively constant as different length AT processes are used. This can be achieved by adding an extra compensating period of π polarized light when an AT is shortened, so that the total duration of exposure to the light is conserved. This is explained schematically in Fig. 3. With these points in mind, we measured the visibility and fringe phase shift as a function of the time difference between first and second AT processes. The results displayed in Fig. 4 were obtained by maintaining the first AT duration at $25 \mu\text{s}$ while changing the length of the second pulse. As we expected, the visibility fell off as the difference between the pulses increased because the spatial overlap of the wave functions was reduced. We have fitted a Gaussian to this data and then applied Eq. (5) to find the visibility function $\mathcal{V}(a)$. With Eq. (4) it is possible to determine the half width at $1/\sqrt{e}$ of the momentum distribution in k space, Δk . We can equate this to a temperature [9] which, for the data of Fig. 4, is found to be $2.0 \pm 0.1 \mu\text{K}$. This is a little colder than the value found using the time of flight technique, but is consistent with the AT being slightly velocity selective.

In Fig. 4(b) the phase of the fringes is plotted for different values of $\tau_2 - \tau_1$. These results are explained well by a consideration of kinetic energy. During an AT pulse of length τ , the wave function experiences a kinetic energy phase shift,

$$\varphi = \frac{1}{2} \frac{M_{Cs}}{\hbar} (2\sqrt{2} v_{\text{recoil}})^2 \tau = 0.093 \times 10^6 \tau. \quad (6)$$

This function is plotted in Fig. 4(b) (solid line) and provides an excellent fit to the data. In principle, the gradient of this line could be used to determine \hbar/M_{Cs} .

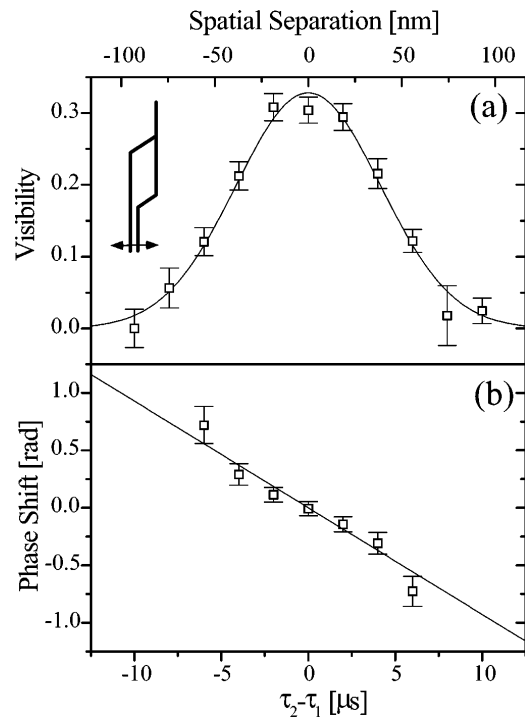

FIG. 4. (a) Visibility and (b) phase shift as a function of the pulse length difference between the first and second AT processes ($\tau_2 - \tau_1$). The Fourier transform of the Gaussian fit gives the momentum distribution and allows a determination of the atomic temperature to be made. In (b) the solid line represents calculated results (with no adjustable parameters) for the phase shift due to the kinetic energy [Eq. (6)].

In this Letter we have presented the first results from a new type of separated path matter wave interferometer for cesium atoms. The interferometer used a sequence of ground state microwave interactions and optical adiabatic transfer pulses. The microwaves were used to create a superposition of the ground hyperfine levels, and the adiabatic transfer then selectively manipulated the momentum of the $F = 4$ component of this superposition. We have demonstrated interference between spatially separated paths and have developed a method for measuring the temperature of our atomic ensemble. The future of this interferometer design seems promising. We are working towards using an AT scheme that will allow larger spatial separations to be realized. This can be achieved by modifying the current technique so that when the atom reaches the $m = 4$ state the laser beam directions are reversed and the atom is transferred back to $m = 0$ with a net change in its momentum of $8\sqrt{2} \hbar k$. Since the atom can be kept in this state without significant magnetic field interactions, it should be possible to achieve separations between the arms of the interferometer of a macroscopic size.

This work was supported by the UK EPSRC and the EU as part of the TMR ‘‘Coherent Matter Wave Interactions’’ network, Contract No. EBRFMRXCT960002.

-
- [1] For an overview of the subject, see *Atom Interferometry*, edited by P. Berman (Academic Press, San Diego, 1997).
- [2] *Molecular Beams*, edited by N.F. Ramsay (Oxford University Press, Oxford, 1986).
- [3] B. Saubaméa *et al.*, Phys. Rev. Lett. **79**, 3146 (1997).
- [4] P. Marte, P. Zoller, and J. Hall, Phys. Rev. A **44**, R4118 (1991); P. Pillet *et al.*, Phys. Rev. A **48**, 845 (1993); J. Lawall and M. Prentiss, Phys. Rev. Lett. **72**, 993 (1994); L. Goldner *et al.*, Phys. Rev. Lett. **72**, 997 (1994); M. Weitz, B. Young, and S. Chu, Phys. Rev. Lett. **73**, 2563 (1994); P. Featonby *et al.*, Phys. Rev. A **53**, 373 (1996).
- [5] J. Kuklinski *et al.*, Phys. Rev. A **40**, 6741 (1989).
- [6] This process is what is meant by the term AT for the remainder of this Letter.
- [7] This is a valid approximation as long as the AT causes no velocity selection. A model of the $\pi - \sigma^+ - \pi$ AT that we have developed indicates that velocity selection for a $3 \mu\text{K}$ sample of atoms is only significant when the pulse length is greater than approximately $20 \mu\text{s}$. We have also confirmed this experimentally.
- [8] This has been verified by the theory alluded to in Ref. [7].
- [9] The temperature T is defined via $k_B T = \hbar^2 (\Delta k)^2 / M_{C_s}$, where M_{C_s} is the mass of a cesium atom.vadjust