

Cryogenic Optical Resonators: A New Tool for Laser Frequency Stabilization at the 1 Hz Level

Stefan Seel, Rafael Storz, Giuseppe Ruoso, Jürgen Mlynek, and Stephan Schiller*

Fakultät für Physik, Universität Konstanz, D-78457 Konstanz, Germany
(Received 27 November 1996; revised manuscript received 19 March 1997)

We demonstrate a laser system with a frequency instability of 0.7 Hz for integration times of 20 s, corresponding to 2.3×10^{-15} fractional instability. This is the lowest short-term instability of any current oscillator. The system uses diode-pumped miniature Nd:YAG lasers stabilized to sapphire Fabry-Pérot reference cavities at liquid helium temperature. Cryogenic optical resonators are promising for precision experiments, such as high-resolution spectroscopy, flywheel oscillators for optical frequency standards, and displacement measurements. As an example, we report a measurement of the ultralow thermal expansion of a sapphire cavity at 1.9 K. [S0031-9007(97)03405-4]

PACS numbers: 42.62.Fi, 06.30.Ft

The quest for oscillators of increasing accuracy and stability is one of the most important continuing developments in physics, spanning over three hundred years, from Huygens' pendulum clocks to today's cold atom and trapped ion clocks [1]. Ultrastable oscillators are essential tools for measurements demanding the highest level of sensitivity, which encompass the study of astrophysical processes (pulsar timing), tests of special [2] and general relativity (gravitational redshift, local Lorentz invariance, local position invariance [3,4]), searches for a possible temporal variation of the fundamental constants [4,5], high-resolution spectroscopy, and measurements of small forces [6] and displacements, for example, in the proposed satellite interferometers [7].

At microwave frequencies, the hydrogen maser and trapped ion standards [8] offer frequency instabilities $< 1 \times 10^{-15}$ for integration times > 1000 s. However, optical oscillators of such stability have not yet been demonstrated. A worldwide effort is under way to achieve this goal [9–11], with emphasis on optical frequency standards based on lasers stabilized to electronic transitions in cold atoms or trapped ions.

There is a complementary need for lasers with instability at the 1 Hz level without the constraint of reproducibility. First, a number of high-resolution spectroscopy experiments, notably on hydrogen [12] and ions in traps and solids [13], are currently limited by the lack of laser sources of sufficient frequency stability. A stability ~ 1 Hz over times on the order of minutes as well as a narrow linewidth are desired to obtain spectra with natural linewidth resolution and for frequency metrology purposes. Second, lasers used as local oscillators for atom/ion frequency standards need to be prestabilized. Prestabilization to optical reference cavities provides suitable "flywheel" oscillators for these applications.

Here we present a novel ultrastable laser oscillator system that exhibits excellent short-term stability and satisfies the above requirements. Our approach is based on cryogenic optical resonators (COREs) [14]. It exhibits important advantages compared to the commonly used

cavities made of low thermal expansion glass ceramics kept at room temperature [15–17]. These cavities typically exhibit a drift of ≈ 1 Hz/s.

In the microwave range, the cryogenic reference cavity approach has already met with considerable success [18]: Superconducting niobium cavities have achieved the lowest instability of any oscillator so far, 2×10^{-16} for 100 s integration time. Over longer integration times (2000 s), cryogenic microwave sapphire resonators reach an estimated instability of 4×10^{-15} .

The resonance frequencies of cavities are determined by their length. However, changes in cavity temperature, in optical power dissipated within the cavity, and mechanical forces deform the cavity. Thus, the prime challenge in the use of cavities for frequency stabilization lies in ensuring that their length be minimally affected by external perturbations. This goal is tackled from two sides: by reducing the level of external disturbances and by making the cavity itself less sensitive to such disturbances. Because of their excellent thermal properties, the cryogenic crystalline cavities used here are advantageous in both respects compared with the conventional room temperature approach. For dielectric crystals, the thermal expansion coefficient drops as $\beta \sim T^3$ as the temperature $T \rightarrow 0$, while the ratio κ/β of heat conductivity κ and thermal expansion coefficient, as well as the thermal diffusivity κ/c (c is the heat capacity per unit volume), are strongly enhanced compared to room temperature. These three properties lead, respectively, to a reduced sensitivity to environmental temperature changes, to internal heating by the circulating laser power, and to a greater precision in active temperature stabilization [19]. Our choice of material has fallen on sapphire (Al_2O_3), which below 5 K has [20] $\beta = 7 \times 10^{-13} T^3/\text{K}^4$, $\kappa/\beta = 7 \times 10^{12} \text{ W/m}$, $\kappa/c = 12 \text{ m}^2/\text{s}$, compared with the values for ultralow expansion glass, $\sim 10^{-9}/\text{K}$, $1 \times 10^9 \text{ W/m}$, $8 \times 10^{-7} \text{ m}^2/\text{s}$, respectively. Sapphire also has a high Young's modulus, which implies a small sensitivity to deformation due to tilt or acceleration.

Our experimental setup (Fig. 1) consists of two similar subsystems, each containing a diode-pumped monolithic Nd:YAG ring laser (1064 nm), an optical cryostat in which the sapphire CORE is mounted, means for detection of laser versus cavity detuning, and a high gain servo loop that controls the laser frequency to accurately track the frequency of the CORE. Both subsystems are mounted on a single optical table, but are otherwise independent. This permits one to infer the average absolute frequency stability of an individual subsystem by measuring the stability of the optical frequency difference.

The two equal cryostats are standard liquid helium systems with superinsulation, liquid nitrogen jackets and two liquid helium pots, a 13 ℓ capacity top pot at 4.2 K, and a 1 ℓ bottom pot below, connected by a capillary tube. Each cavity is located near the bottom of the cryostat vacuum chamber, supported vertically by a copper holder which is itself connected by a solid high thermal conductivity copper post to the bottom plate of the lower pot. Three heat shields surround the cavities. "Cold glass" windows (Schott WG 225) serve as thermal radiation traps while allowing passage of the laser beam through the cryostat. CORE operating temperatures between 5 and 1.3 K can be chosen by pumping with powerful rotary pumps on the liquid helium in the lower pot.

The two optical cavities (Research Electro-Optics, Colorado) consist of 3 cm long cylindrical sapphire spacer tubes (10 mm inner diam, 26 mm outer diam, c axis parallel to cylinder axis). Their end faces are polished flat, and sapphire mirrors are optically contacted to them. The substrates have 1 m concave radii of curvature so that stable Gaussian resonator eigenmodes are formed. Dielectric multilayer coatings are deposited on the mirror substrates. The cavity linewidths are 42 and 88 kHz (finesse 120 000 and 57 000), incoupling levels are about 70% and 30%, respectively.

The Nd:YAG lasers employed are a favorable choice for the stabilization experiment since they exhibit a high

degree of frequency stability even under free-running conditions, with short-term instability of 2 kHz (for integration times of 20 ms) and drift <10 MHz over 1 h.

The deviation of the laser frequency from the chosen cavity mode is measured using the frequency modulation technique [21], with the error signal detected via the laser light reflected from the cavity. The required frequency modulation is imparted to the light at 0.5 MHz by directly modulating the laser resonator length (modulation index ~ 0.7). The servo systems contain a single integrator stage and have 10 kHz bandwidth. In previous work, we have verified that the lock instability of the laser frequency, i.e., relative to the cavity resonance, is at the 0.1 Hz level for 50 s integration time [22]. The light transmitted through the cavities is monitored with a CCD camera for mode identification and with quadrant photodetectors to follow changes in orientation of the cavity as well as internally dissipated laser power. Our best results were obtained for laser input powers at the 30 μ W level.

Two beams are split off each laser and overlaid on a fast photodetector that generates an ac current at the difference of the two optical frequencies. This beat frequency is measured by a frequency counter (1 s averaging time) and recorded every 1 s by a computer for subsequent statistical analysis. To characterize the frequency stability, we use the two-sample Allan variance $\sigma_y(\tau)^2 = \langle (\bar{y}_{k+1} - \bar{y}_k)^2 \rangle / 2$, i.e., the variance of the difference between subsequent beat frequency measurements \bar{y} averaged over an integration interval τ .

We achieve the lowest frequency instabilities by operating the CORE systems at 3 K with active temperature stabilization and with the pumps off. The periods of low instability have typical lengths of 5 h. Figure 2 (left inset) shows a typical beat frequency time trace. From this trace the root Allan variance $\sigma = \sigma_y / \sqrt{2}$ ("instability") for a single system is obtained. The τ dependence is typical of cavity-stabilized oscillators. The decrease at short

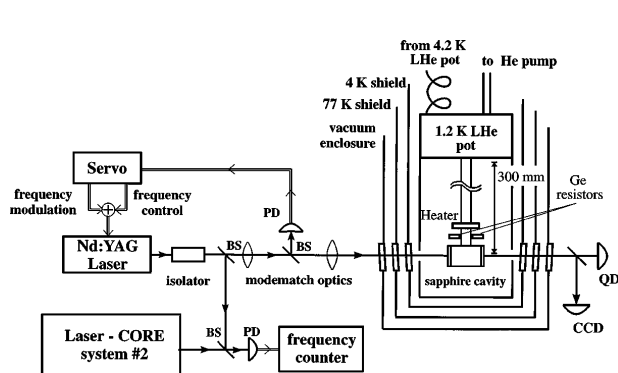

FIG. 1. Schematic of the setup. Only the bottom part of one cryostat is shown. PD: photodetector, BS: beam splitter, CCD: video camera, QD: quadrant detector. The laser frequency modulation serves for the error signal generation. The beat frequency between the two lasers is 2.0 GHz.

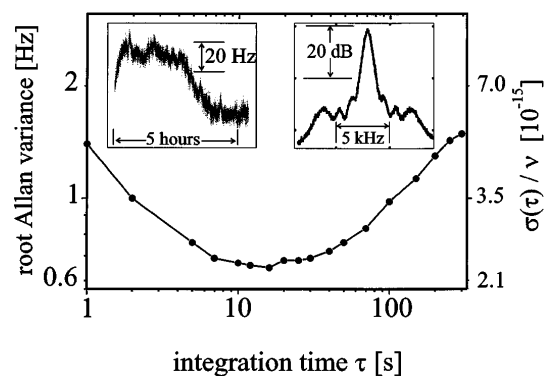

FIG. 2. Typical short-term frequency instability for operation at 3 K, referred to a single system. Left inset: beat frequency trace from which the instability was obtained. Right inset: spectrum $W(f)$ of the beat frequency signal, averaged over 1 s.

integration times occurs due to averaging of disturbances such as cavity motion induced Doppler effect and cavity length fluctuations induced by mechanical vibrations. The upturn for long integration times is due to drift. The average individual instability reaches a minimum of 0.65 Hz (2.3×10^{-15}) at 20 s integration time.

Complementary to the time domain instability measurements we have performed measurements of spectral purity, i.e., of the spectrum $W(f)$ of the beat signal $\sim \cos 2\pi y t$. Both $\sigma(\tau)$ and $W(f)$ are integral transforms of the spectrum of the beat frequency y itself [23], which, however, was not directly measured in our experiment. The right inset in Fig. 2 shows the spectrum of the beat signal after mixing it down from 2 GHz to a frequency in the kHz range. The spectrum remains unchanged for averaging times between seconds and several minutes. The beat note FWHM linewidth is 420 Hz, and originates mostly from vibrational noise, since the system has essentially no vibration isolation. The linewidth of the more stable of the two lasers is at least a factor $\sqrt{2}$ smaller.

Our system was operated uninterruptedly for up to two months at a bottom pot temperature of 4.2 K. Figure 3 shows the typical result for the beat frequency over a period of 65 h, the time between liquid He refills. It can be seen that the beat frequency deviation remains within 250 Hz over the period shown. During this run, automatic liquid N₂ refill systems replenished periodically the two cryostats (every 2 and 2.5 h, respectively). Since these procedures perturb the systems, with short-term beat frequency excursions of about 200 Hz, we have removed 30 min of data beginning with each refill. The oscillations occurring in the beat frequency data are the remnants of the refills. The disturbances are of mechanical origin: Refills cause deflection of the inner cryostat structures that support the cavities and an ensuing displacement of the cavities with respect to the laser beams. This changes the overlap between laser beam and cavity mode, and thus several parameters of the optical system, which affect the lock frequencies. The cavity tilts and displacements, monitored with quadrant detectors on the transmitted beam, show a

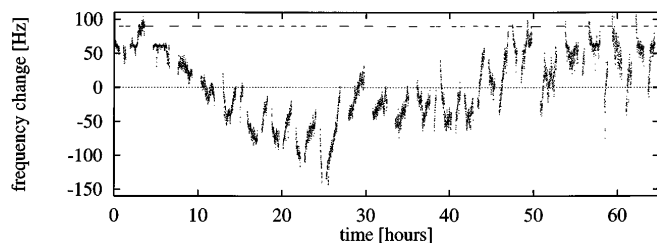

FIG. 3. Long-term time trace of the frequency difference of two independent cryogenic optical resonator systems at 5 K. Every point corresponds to a 20 s average of the beat frequency. The dashes, covering 20% of the run, indicate the intervals during which the frequency difference has systematic deviations (about 200 Hz) due to mechanical disturbances caused by the refill of liquid nitrogen into the cryostats.

strong correlation with the beat frequency change. We attribute beat frequency changes on a time scale of 20 h to mechanical effects related to liquid He depletion.

An analysis of the root Allan variance for the complete 65 h data set shows a minimum instability $\sigma = 2.5$ Hz for $\tau = 10$ s. It remains below 10 Hz for integration times up to 1000 s.

In Fig. 4 we compare our short-term instability results with those of other state-of-the-art optical oscillators. For integration times in the range of 1–200 s, our system represents the most stable optical oscillator.

As a first demonstration of the capability of the system for precision measurements, Fig. 5 shows the determination of the thermal expansion coefficient and the response time of the cavity at 1.9 K, measured by modulating the temperature of one CORE and observing the resulting change in beat frequency. The observed cavity expansion coefficient, $\beta = 5 \times 10^{-12} \text{ K}^{-1}$, is the lowest obtained to date. The sensitivity of the present system for measurements of thermal expansion is 2 orders of magnitude larger than that achieved so far [20,25].

It is natural to ask about the future potential of COREs. Based on the results obtained, we believe that an order-of-magnitude improvement in frequency stability should be possible for the present system, by implementing laser beam pointing and cavity tilt and vibration control systems. It is worth mentioning that the fundamental limits stemming from Brownian cavity length fluctuations and from the quantum limit in the read-out precision of the frequency deviation are still several orders of magnitude lower. This leaves open a large window of opportunity. Some of the technical hurdles likely to be encountered along the way may be overcome by a second-generation, all-cryogenic system, where laser and cavity form a compact unit operated at liquid helium temperature.

In conclusion, we have demonstrated that the cryogenic optical resonator concept can be used for laser frequency

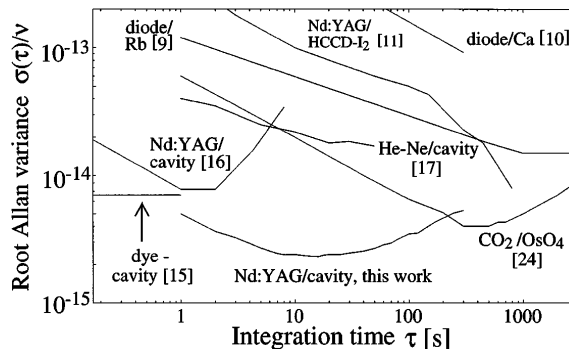

FIG. 4. Comparison of the fractional frequency stability of laser oscillators stabilized to molecular or atomic transitions and to optical cavities. Shown are the instabilities for a single oscillator.

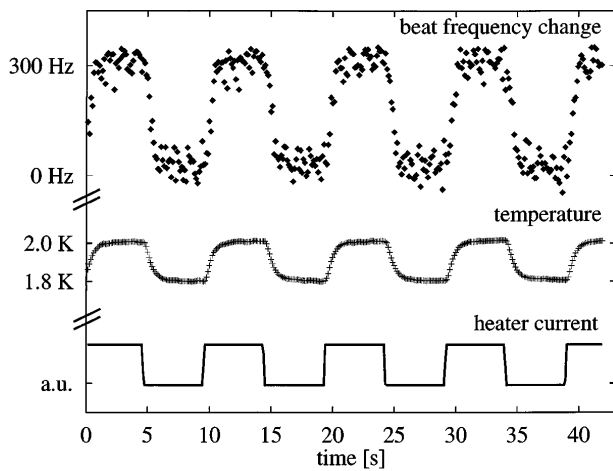

FIG. 5. Response of the sapphire cavity length to a temperature modulation produced by the heater attached to the copper post. The 280 Hz beat frequency excursion corresponds to an effective cavity length change of 3×10^{-14} m. The cavity temperature response time is 0.8 s, limited by thermal resistance of the cavity support.

stabilization below the 3×10^{-15} level for integration times between 4 and 70 s. These short-term instabilities are the lowest of any currently operating oscillator. COREs with dielectric coatings appropriate for other wavelengths should be useful as reference cavities for the stabilization of lasers for precision spectroscopy, and as flywheel oscillators for cold-atom or single-ion optical clocks.

We wish to thank R. Leonhardt, P. Leiderer, R. Conradt, and D. Reinelt for their important advice and assistance with the cryogenics; S. Hahn and S. Eggert for technical work; and K. Jäck for participation. S.S. acknowledges the collaboration of R.L. Byer and R. Liu in the conceptual stage of this project. Financial support was provided by the Deutsche Forschungsgemeinschaft and the Optik-Zentrum Konstanz.

Note added.—A He-Ne/CH₄ laser with an instability $\sigma(10 \text{ s}) = 5 \times 10^{-15}$ has been reported [P. V. Pokasov (private communication)].

*Electronic address: stephan.schiller@uni-konstanz.de
<http://quantum-optics.physik.uni-konstanz.de>

[1] *Proceedings of the Fifth Symposium on Frequency Standards and Metrology*, edited by J. Bergquist (World Scientific, Singapore, 1996); see also the special issue on Time

and Frequency, edited by J. Jepsen and D. W. Hanson, Proc. IEEE **79**, No.7 (1991).

- [2] A. Brillet and J.L. Hall, Phys. Rev. Lett. **42**, 549 (1979); D. Hils and J.L. Hall, Phys. Rev. Lett. **64**, 1697 (1990).
- [3] R.F.C. Vessot *et al.*, Phys. Rev. Lett. **45**, 2081 (1980); C.J. Berglund *et al.*, Phys. Rev. Lett. **75**, 1879 (1995).
- [4] J.P. Turneaure *et al.*, Phys. Rev. D **27**, 1705 (1983); A. Godone *et al.*, Phys. Rev. D **51**, 319 (1995).
- [5] J.D. Prestage *et al.*, Phys. Rev. Lett. **74**, 3511 (1995).
- [6] H. Walesch *et al.*, IEEE Trans. Instrum. Meas. **44**, 491 (1995).
- [7] P. Bender *et al.*, Max-Planck Institute for Quantum Optics, Munich, Germany, Report No. 208 (1996).
- [8] R.F.C. Vessot, Proc. IEEE **79**, 1040 (1991); R.L. Tjoelker *et al.*, in Ref. [1], p. 33.
- [9] Y. Millerioux *et al.*, Opt. Commun. **108**, 91 (1994).
- [10] H. Schnatz *et al.*, Phys. Rev. Lett. **76**, 18 (1996).
- [11] J. Ye *et al.*, IEEE Trans. Instrum. Meas. **46**, 178 (1997).
- [12] T. Andrae *et al.*, Phys. Rev. Lett. **69**, 1923 (1992); C.L. Cesar *et al.*, Phys. Rev. Lett. **77**, 255 (1996); S. Bourzeix *et al.*, Phys. Rev. Lett. **76**, 384 (1996).
- [13] M. Roberts *et al.*, Phys. Rev. Lett. **78**, 1876 (1997); R. Yano *et al.*, Opt. Lett. **16**, 1884 (1991); R.W. Equall *et al.*, Phys. Rev. Lett. **72**, 2179 (1994).
- [14] J.-P. Richard and J.J. Hamilton, Rev. Sci. Instrum. **62**, 2375 (1991); S. Schiller *et al.*, Proc. Soc. Photo-Opt. Instrum. Eng. **2378**, 138 (1995); M. Notcutt *et al.*, Cryogenics **36**, 13 (1996).
- [15] J. Dirscherl *et al.*, Opt. Commun. **91**, 131 (1992).
- [16] N.M. Sampas *et al.*, Opt. Lett. **18**, 947 (1993).
- [17] J.L. Hall *et al.*, in Ref. [1], p. 267.
- [18] J.P. Turneaure and S.R. Stein, in *Near Zero*, edited by J.D. Fairbank *et al.* (Freeman, New York, 1988), p. 414; R.T. Wang and G.J. Dick, *Proceedings of the 45th Annual Symposium on Frequency Control* (IEEE, New York, 1991), p. 491; A.N. Luiten *et al.*, IEEE Trans. Instrum. Meas. **44**, 132 (1995).
- [19] R. Liu, S. Schiller, and R.L. Byer, Stanford University, internal report, 1993. Temperature stability at the nK level has been demonstrated at cryogenic temperature [X. Qin *et al.*, Cryogenics **36**, 781 (1996)].
- [20] G.K. White and R.B. Roberts, High Temp.-High Press. **15**, 321 (1983); Y.S. Touloukian and E.H. Buyco, *Thermophysical Properties of Matter* (IFI/Plenum, New York, 1970), Vol. 5.
- [21] R.W.P. Drever *et al.*, Appl. Phys. B **31**, 97 (1983).
- [22] G. Ruoso *et al.*, Opt. Commun. **133**, 259 (1997).
- [23] D.S. Elliott *et al.*, Phys. Rev. A **26**, 12 (1982).
- [24] O. Acef, Opt. Commun. **134**, 479 (1997).
- [25] C.T. Taylor *et al.*, Opt. Commun. **131**, 311 (1996).