

## State Selective Scattering Angle Dependent Capture Cross Sections Measured by Cold Target Recoil Ion Momentum Spectroscopy

V. Mergel,<sup>1</sup> R. Dörner,<sup>1</sup> J. Ullrich,<sup>2</sup> O. Jagutzki,<sup>1</sup> S. Lencinas,<sup>1</sup> S. Nüttgens,<sup>1</sup> L. Spielberger,<sup>1</sup> M. Unverzagt,<sup>1</sup>  
C. L. Cocke,<sup>3</sup> R. E. Olson,<sup>4</sup> M. Schulz,<sup>4</sup> U. Buck,<sup>5</sup> E. Zanger,<sup>1</sup> W. Theisinger,<sup>1</sup> M. Isser,<sup>1</sup>  
S. Geis,<sup>1</sup> and H. Schmidt-Böcking<sup>1</sup>

<sup>1</sup>*Institut für Kernphysik, Universität Frankfurt, D60486 Frankfurt, Germany*

<sup>2</sup>*Gesellschaft für Schwerionenforschung Darmstadt m.b.H., Planckstrasse 1, D64291 Darmstadt, Germany*

<sup>3</sup>*Department of Physics, Kansas State University, Manhattan, Kansas 66506*

<sup>4</sup>*Department of Physics, University of Missouri-Rolla, Rolla, Missouri 65401*

<sup>5</sup>*Max-Planck-Institut für Strömungsforschung, D-3400 Göttingen, Germany*

(Received 15 July 1994)

We have developed a new kind of recoil ion momentum spectroscopy technique, using a precooled supersonic gas jet target, to determine state selective, scattering angle dependent cross sections for swift ion-atom collisions (0.25, . . . , 1 MeV He<sup>2+</sup> on He), by measuring the transverse and longitudinal momentum of the recoil ion. A longitudinal momentum resolution of  $\pm 0.13$  a.u. was achieved, about a factor of 30 better than ever obtained before, which enables a clear separation of *K* and *L* shell capture. In the transverse direction a resolution corresponding to a projectile scattering angle uncertainty of  $\Delta\vartheta_p = \pm 1$   $\mu$ rad was obtained.

PACS numbers: 34.50.Bw, 34.70.+e

A well established, powerful tool to determine inelastic energy transfers (*Q* values) in slow ion-atom collisions is translational spectroscopy, i.e., the measurement of the change of the projectile kinetic energy (*E<sub>p</sub>*) [1]. The typical resolution for this traditional technique is in the range of  $\Delta Q/E_p = 10^{-4}$ . Only a few experiments with better resolution [2] or at higher energies [3] have been reported.

It has been pointed out [4,5] and recently been demonstrated [6,7] that the measurement of the longitudinal momentum transfer (parallel to the ion-beam axis) to the recoiling target ion (*p<sub>||R</sub>*) offers a novel possibility to determine *Q* values even at much higher projectile energies and for poor definition of the incoming beam longitudinal momentum. These measurements, however, suffered from the target thermal motion and extension which restricted the resolution to  $\Delta p_{||R} = \pm 5.5$  a.u. [7] and  $\Delta p_{||R} = \pm 4$  a.u. [6].

In this Letter we report on a tremendous improvement of the *p<sub>||R</sub>* determination of about a factor of 30 to  $\Delta p_{||R} = \pm 0.13$  a.u. The corresponding resolution in the *Q* value of  $\Delta Q/E_p = 1.1 \times 10^{-5}$  enabled for the first time the resolution of capture into the *K* shell from the one into the *L* shell of the He<sup>2+</sup> projectile at a collision energy of 1 MeV. The recoil ion momentum resolution does not depend in any way on the projectile velocity and only in second order on the beam divergence and energy spread. By modifying the extraction geometry we envisage another factor of 10 improvement in the near future.

Since the recoil ion momentum is measured in all three dimensions, information about the transverse momentum exchange between target and projectile (i.e., the scattering

angle  $\vartheta_p$ ) is obtained simultaneously. Thus we also determined the scattering angle dependence of the state selective capture cross sections. For the transverse momentum component of the recoil ion (*p<sub>⊥R</sub>*) the apparatus yields a precision of 0.02 a.u., which is for a 1 MeV He on He collision equivalent to a resolution in projectile scattering angle of  $\Delta\vartheta_p = \pm 1$   $\mu$ rad. This is already about a factor of 50 better than the best direct  $\vartheta_p$  determination ever achieved and again the precision is, in first order, independent of the beam quality.

In the approximation of small scattering angles and small changes of projectile energy in the collision (both are very well fulfilled in almost all swift and fast ion-atom collisions), *p<sub>||R</sub>* and *p<sub>⊥R</sub>* are independent of each other and carry different information on the collision process. For a pure electron capture reaction from energy and momentum conservation it follows (in atomic units) [8]

$$p_{||R} = -\frac{Q}{v_p} - \frac{qv_p}{2}, \quad (1)$$

$$p_{\perp R} = -p_{\perp P} = -m_p v_p \tan \vartheta_p, \quad (2)$$

where *v<sub>p</sub>* is the projectile velocity, *m<sub>p</sub>* its mass, *q* the number of electrons transferred from the target to the projectile, and *Q* the inelasticity of the reaction (i.e., the difference between the initial and the final sum over all electronic binding energies). It is obvious that for capture reactions, where no electron is emitted to the continuum, only well defined discrete *p<sub>||R</sub>* are possible, showing directly the capture to different final states, while *p<sub>⊥R</sub>* reflects the projectile scattering angle. If some electrons are emitted to the continuum (for He only one is possible, if the other one is captured), the measurement of the recoil is no longer equivalent to the one of the projectile.

However, then the recoil ion transverse momentum component carries new information on the impact parameter of the collision. Because of the big solid angle of cold target recoil ion momentum spectroscopy (COLTRIMS) it is possible to spectroscopy two momentum components of the projectile or an outgoing electron in coincidence with the recoil ion. Then, for example, in a transfer or single ionization the reaction kinematics are also completely determined, so that the  $Q$  value and the scattering angle can be calculated too [8].

The  $\text{He}^{2+}$  on He electron capture reaction was chosen as a test case because of its importance to magnetically confined nuclear fusion research. With the advent of D-T runs at the Princeton TFTR tokamak in the fall of 1993, and similar planned experiments on JET in 1995, it is necessary to be able to measure the alpha particle confinement and time evolution in the fusion plasmas. The diagnostic used for these investigations is to inject fast, neutral helium and then measure the line radiation from single electron capture to excited states. Signals of fast alpha particles at energies to 600 keV were realized in the recent TFTR runs. However, cross section data exist to only 240 keV [9]. One purpose of our work is to provide these critically needed state selective cross sections.

Figure 1 shows the schematics of the new apparatus. To form a cold localized helium gas target, a supersonic gas jet is used. The helium gas expands through a  $30\ \mu\text{m}$  hole. The gas source is mounted on the cold finger of a cryo pump and is cooled down to 14 K. The gas jet is collimated at a distance of 11 mm from the expansion hole by a skimmer of 0.3 mm diameter. The gas jet leaves

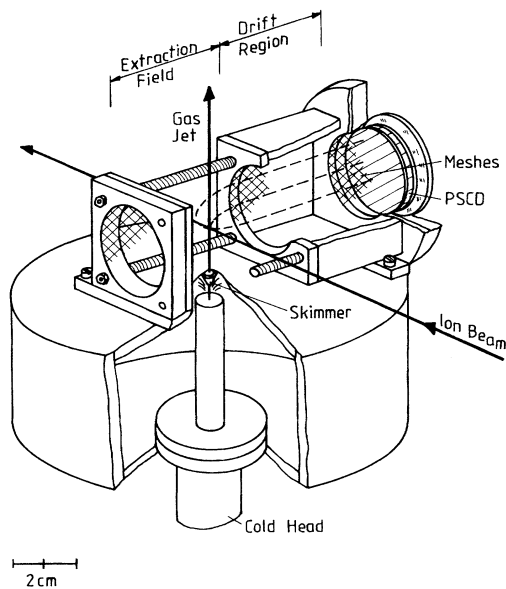

FIG. 1. High resolution recoil ion momentum spectrometer with precooled supersonic gas jet target.

the collision chamber through a hole of 1 cm diameter into a jet dump, pumped by a 360 l/s turbomolecular pump to reduce the helium residual gas pressure to  $10^{-8}$  mbar. Typical pressures are 200 mbar on the high pressure side of the  $30\ \mu\text{m}$  hole and  $5 \times 10^{-4}$  mbar in the source chamber. Both chambers are separately pumped by a 360 l/s turbomolecular pump. At the collision point 3 cm above the skimmer, the helium gas jet has a diameter of 1.1 mm and a local density of  $1 \times 10^{11}/\text{cm}^2$ . The internal temperature is about 0.1 K in the jet direction [10]. Perpendicular to the jet the atoms have a momentum spread of  $\pm 0.02$  a.u. given by the velocity of the jet and the skimming geometry.

The recoil ions created at the intersection point of the gas jet with the ion beam are extracted by a homogeneous electrostatic field of 330 mV/cm. After passing a field free drift region they are postaccelerated onto a position sensitive channel plate detector with a position resolution of  $< 0.2$  mm. Great care has been taken to assure proper field conditions in the spectrometer area. The drift region is separated from the extraction region by a woven mesh of 0.25 mm mesh width. A stack of three of these meshes with 1 mm spacing shields the drift region from the strong postacceleration field. On all parts, including the meshes, a thin layer of carbon is evaporated to avoid contact potentials. A homogeneous field in the extraction region is obtained by shielding this area from external potentials with a carbon fiber. One fiber of  $7\ \mu\text{m}$  diameter and 10 m length is wound around four supporting germanium coated isolator screws. The fiber defines the potential in the extraction region and divides the voltage.

The time of flight of the recoil ions is measured by a coincidence with the charge exchanged projectiles. From the time of flight and the position on the channel plate detector the three momentum components of the recoil ion are calculated.

The resolution of the current apparatus for  $p_{\parallel R}$  is  $\pm 0.13$  a.u. (Fig. 2); it is due to the uncertainty as to where the recoil ion was produced, given by the diameter of the gas jet. For the momentum component in the direction of the extraction field, the different starting points of the recoil ions are focused in time to first order due to the ratio of 1:2 of the extraction to the drift path length. Thus, the momentum resolution in the direction of the extraction field is  $\pm 0.02$  a.u., only restricted by the internal momentum spread of the jet perpendicular to the jet direction. This momentum resolution corresponds to the momentum of an electron with 10 meV kinetic energy. A spectrometer with the extraction field in the beam direction is under construction. This will facilitate an improved resolution by a factor of 10 for  $Q$ -value measurements and the possibility to increase the extraction voltage without losing precision. This will enable us to extend the properties of the spectrometer for collisions with much higher momentum exchanges than in these test measurements.

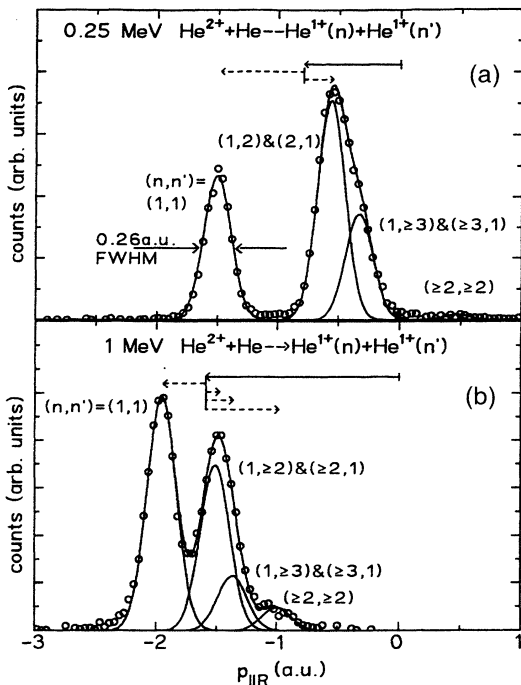

FIG. 2. (a),(b) Longitudinal momentum distribution for the recoil ions from the reaction 0.25 and 1 MeV  $\text{He}^{2+} + \text{He} \rightarrow \text{He}^{1+} + \text{He}^{1+}$ . The momentum resolution is 0.26 a.u. FWHM. The peaks correspond to the different states of projectile and target as indicated in the figure. The full arrow shows the contribution of the term  $qv_P/2$  from Eq. (1), which is due to the mass transfer between target and projectile; the dashed arrows show the  $Q/v_P$  term from Eq. (1) for the different states.

The measured  $p_{\parallel R}$  distribution for single capture collisions of 0.25 and 1 MeV  $\text{He}^{2+}$  on He is shown in Figs. 2(a) and 2(b). The measured recoil ion momentum is, according to Eq. (1), equal to the sum of two terms. The backward component, indicated by the full arrow in Figs. 2(a) and 2(b), is due to the mass transfer of the captured electron from the target to the projectile. The  $Q/v_P$  term, indicated by the different dashed arrows, is due to the fact that the recoil ion has to compensate for the momentum change of the projectile caused by the  $Q$  value of the reaction. As in translational spectroscopy the experiment cannot determine whether the projectile or the target is in the excited state for this symmetric collision system.

The total and state selective cross sections as a function of the projectile energy obtained from these spectra are shown in Figs. 3(a) and 3(b). The data are normalized to total cross sections from [11] for single ionization which have been measured simultaneously. Good agreement of our total cross sections with previously measured data from different authors [11–13] is observed within the statistical error bars. Apart from discrepancies with predictions of continuum distorted wave calculations at low

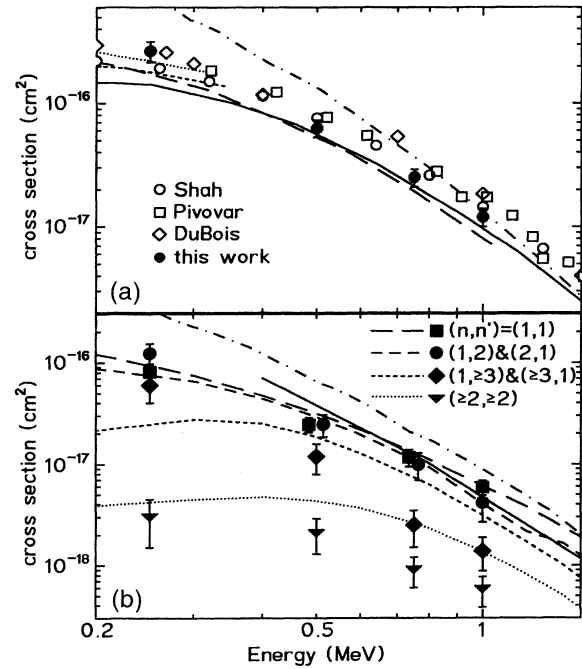

FIG. 3. (a) Total cross section for the reaction  $\text{He}^{2+} + \text{He} \rightarrow \text{He}^{1+} + \text{He}^{1+}$ . Full circles are this work, open circles from [11], squares from [12], diamonds from [13], dash-dotted line is CDW calculation [14], dotted line is coupled channel calculation [15], short dashed line is molecular orbital calculation [16], long dashed line is coupled channel calculation [17], and full line is Eikonal distorted wave calculation [18]. (b) State selective capture cross section as indicated in the figure. The experiment does not distinguish which partner is in the excited state for the symmetric collision system. Dash-dotted [14] and full [19] lines represent both CDW calculations for ground state capture. Squares are ground state capture (experiment), circles are capture or target excitation to  $L$  shell (experiment), diamonds are capture or target excitation to  $M$  or higher shell (experiment), and triangles are capture and target excitation to  $L$  or higher shell (experiment). Long dashed line is ground state capture (dCTMC), dashed line is capture or target excitation to  $L$  shell (dCTMC), short dashed line is capture or target excitation to  $M$  or higher shell (dCTMC), and dotted line is capture and target excitation to  $L$  or higher shell (dCTMC).

energies, the experimental data are reasonably described by various theoretical calculations.

Looking at the state selective cross sections [Fig. 3(b)] one observes that with increasing projectile energy the population of tightly bound states relative to total capture increases, as is expected from the consideration of velocity matching. The experimental error of the ratio between the  $(n, n') = (1, 1)$  and  $(1, 2)$  and  $(2, 1)$  exit channels is much smaller than the error for the absolute cross section, shown in the figure, which results from the normalization.

The quantum mechanical calculations, which are only available for ground state capture, compare well to the experimental data, as far as continuum distorted wave (CDW) and coupled channel calculations are concerned.

CDW cross sections from [14,19] are above our data in the whole energy regime investigated, especially at energies  $< 0.5$  MeV. Results using the classical trajectory Monte Carlo (dCTMC) model [20] are in good agreement with the experiment for all final states.

Differential cross sections in the transverse momentum transfer for the state selective capture in Figs. 4(a) and 4(b) are obtained by evaluating the transverse momentum of the recoil ion. While the capture to the excited states shows a smooth decrease at larger transverse momenta, the  $K$  shell capture exhibits an oscillating structure at the lower impact energy. This interference structure for  $K$ - $K$  transfer is well known for slow collisions, where the classical electron orbit velocity is large compared to the projectile velocity [21].

In conclusion, we have demonstrated the power of COLTRIMS for high precision energy gain spectroscopy.

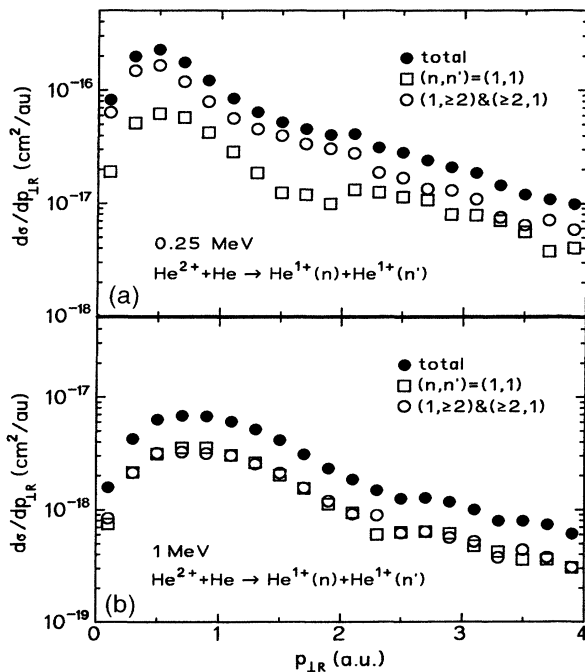

FIG. 4. (a),(b) Differential state selective capture cross sections. The  $x$  axis shows the transverse momentum of the recoil ion  $p_{\perp R}$ , which is equivalent to the projectile scattering angle  $\vartheta_P$  ( $\tan \vartheta_P = p_{\perp R}/p_0$ , where  $p_0$  is the incoming projectile momentum). Full circles are the sum over all states, squares are both partners in ground state, and open circles are one collision partner in any excited state.

COLTRIMS enables at all beam energies  $Q$ -value and scattering angle measurements for ion-atom collisions almost independent of the beam energy spread and angular divergence. The resolution of  $\pm 0.13$  a.u. for the longitudinal momentum of the recoil ion is equivalent to  $\Delta Q/E_p < \pm 3.5 \times 10^{-9}$  for 1 GeV/u U on He collisions or to an energy resolution  $\Delta Q = \pm 3$  eV for a 5 MeV uranium beam. Such experiments are planned at the storage ring (ESR) at GSI, to be done in an electron-recoil coincidence measurement with the longitudinal recoil extraction for the transfer ionization reaction channel.

Because of the unique combination of high resolution and a solid angle of nearly  $4\pi$ , this technique is ideally suited for multiple coincidence studies of all kinds of atomic collision processes.

The work was supported by DFG, BMFT, and GSI. R.E.O. acknowledges support by the DOE Office of Fusion Energy, C.L.C. by the Max Planck Forschungspreis, and M.S. by the National Science Foundation.

- [1] M. Barat *et al.*, J. Phys. B **25**, 2205-2243 (1992).
- [2] J. T. Park *et al.*, Adv. At. Mol. Phys. B **25**, 67 (1983).
- [3] R. Schuch *et al.*, Phys. Rev. Lett. **60**, 925 (1988).
- [4] R. Dörner *et al.*, in *Electronic and Atomic Collisions, Invited Papers of the ICPEAC XVII*, edited by W. R. MacGillivray, I. E. McCarthy, and M. C. Standage (Adam Hilger, London, 1991), p. 351.
- [5] J. Ullrich *et al.*, Nucl. Instrum. Methods Phys. Res., Sect. A **268**, 216 (1988).
- [6] R. Ali *et al.*, Phys. Rev. Lett. **69**, 2491 (1992).
- [7] V. Frohne *et al.*, Phys. Rev. Lett. **71**, 696 (1993).
- [8] V. Mergel, Master's thesis, Universität Frankfurt/Main, 1994 (unpublished).
- [9] H. O. Folkerts *et al.*, J. Phys. B **26**, L619-24 (1993).
- [10] G. Brusdeylins *et al.*, *XII Symposium on Molecular Beams, Perugia 1989, Book of Abstracts*, edited by V. Aquilanti (University of Perugia, Perugia, 1989), p. 98.
- [11] M. B. Shah *et al.*, J. Phys. B **18**, 899 (1985).
- [12] L. I. Pivovarov *et al.*, Sov. Phys. JETP **15**, 1035 (1982).
- [13] R. D. DuBois, Phys. Rev. A **36**, 2585 (1987).
- [14] Dz. Belkic and R. Gayet, J. Phys. B **10**, 1923 (1977).
- [15] K. Gramlich *et al.*, J. Phys. B **22**, 2567 (1989).
- [16] M. Kimura, J. Phys. B **21**, L19 (1988).
- [17] R. Shingal and C. D. Lin, J. Phys. B **24**, 251 (1991).
- [18] G. R. Deco *et al.*, J. Phys. B **17**, L707 (1984).
- [19] K. M. Dunseath *et al.*, J. Phys. B **24**, 5003 (1991).
- [20] L. Meng *et al.*, J. Phys. B **26**, 3387 (1993).
- [21] W. C. Keever *et al.*, Phys. Rev. **150**, A43 (1966).