

## Density Matrix Formulation for Quantum Renormalization Groups

Steven R. White

*Department of Physics, University of California, Irvine, California 92717*

(Received 22 May 1992)

A generalization of the numerical renormalization-group procedure used first by Wilson for the Kondo problem is presented. It is shown that this formulation is optimal in a certain sense. As a demonstration of the effectiveness of this approach, results from numerical real-space renormalization-group calculations for Heisenberg chains are presented.

PACS numbers: 75.10.Jm, 02.70.+d, 05.30.-d

While Wilson's solution of the Kondo problem [1] using a numerical renormalization-group (RG) technique was a dramatic breakthrough, the numerical approach he used has since had little success for anything but impurity problems. When applied to quantum lattice problems in a real-space blocking form, the approach is flawed in its treatment of the boundaries of a block [2]. The boundary errors make quantitatively accurate results impossible for most problems.

Here we show how to eliminate these flaws for an arbitrary interacting quantum lattice system. We reformulate the old approach in terms of density matrices, and show that the new approach is optimal in a certain sense. The density matrix framework provides an important conceptual basis for numerical RGs; for example, the zero-temperature, one-dimensional (1D), real-space algorithm we present here can easily be generalized to finite temperature, 2D or 3D, or momentum space (although the calculations may not always be practical). The approach does not require small couplings, can treat disordered systems, and of course, does not have the minus sign problem that plagues the quantum Monte Carlo approach.

We demonstrate the approach on  $S = \frac{1}{2}$  and  $S = 1$  Heisenberg antiferromagnetic spin chains. Results are substantially better than the best available from Monte Carlo calculations, similar in accuracy and the variety of properties measured to what one expects from exact diagonalization, but one can treat lattices hundreds of sites long. We present results for the spatial spin density distribution of the fractional  $S = \frac{1}{2}$  spins at the ends of open  $S = 1$  chains, and provide improved results for the ground-state energy and Haldane gap of  $S = 1$  chains. The computational resources required for these calculations are relatively small; if extreme accuracy is not required, a modest workstation is adequate.

We first describe the standard numerical RG procedure, as applied in a 1D real-space blocking context. One first breaks the infinite chain into a set of identical blocks  $A$ . One diagonalizes the Hamiltonian matrix  $H_{AA}$  for two neighboring blocks considered together, and uses  $m$  of its lowest-lying eigenstates to form a new, simpler Hamiltonian  $H_{A'}$  representing a block twice as large [see Fig. 1(a)]. One repeats this procedure using the new larger blocks and the new effective Hamiltonian. One as-

sumes in using this procedure that only the lowest-lying block eigenstates play a dominant role in forming states of larger blocks at later iterations.

For the formation of the effective Hamiltonian out of the low-lying eigenstates, we will only consider the approach used by Wilson for the Kondo problem, involving a change of basis to the new set of block eigenstates. We can write this procedure formally as

$$H_{A'} = O H_{AA} O^\dagger, \quad (1)$$

where  $O$  is an  $m \times l$  matrix, and  $l$  is the dimension of  $H_{AA}$ . The rows of  $O$  are the  $m$  lowest eigenstates of  $H_{AA}$  [3].

Although the eigenstates of  $H_{AA}$  are natural states to use in forming  $O$  (the states kept), they are not optimal. In particular, because  $H_{AA}$  does not include any connections to surrounding blocks, its eigenstates have inappropriate features at the edges of a block. They are optimal only in the limit that the connections to other blocks vanish. Recently White and Noack [2] considered these problems with real-space RGs in the context of a very simple single-particle model. Several solutions, involving different treatments of boundary conditions, were proposed and shown to work very well for the single-particle model. These solutions all involved different

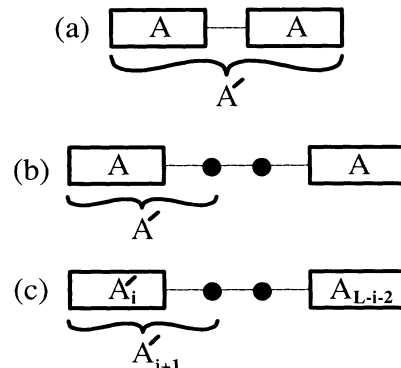

FIG. 1. Various blocking schemes for real-space renormalization groups on a 1D system. The standard approach is shown in (a). In the infinite-system method (b) and the finite-system method (c), one diagonalizes the entire system and forms the reduced density matrix for the part labeled  $A'$ . The solid circles represent single sites.

choices for the states kept. Here we show how to choose the *optimal* set of states to keep in a way appropriate for *interacting systems* as well as noninteracting.

The density matrix approach we present here is most closely related to the superblock method discussed by White and Noack, where one diagonalizes a larger system of three or more blocks (the superblock), of which  $AA$  is a part. The states one keeps are the projections of the low-lying states of the superblock onto  $AA$ . In the single-particle case, the projection operation is trivial. However, for a many-particle wave function, the projection of a wave function onto  $AA$  is not uniquely defined, nor does it produce only one state. In general, one expects it to project onto a complete set of block states. However, some of these states are more important than others; the density matrix tells us which states are the most important.

Let us assume that we know the state of the entire lattice (or a superblock in a practical calculation). We wish to generate a set of states for  $AA$  which are especially appropriate to represent the properties of  $AA$  when the lattice has this given state. It is straightforward to show that the eigenvectors with the largest eigenvalues of the density matrix of  $AA$  are the optimal states to keep, in the sense that they most accurately reproduce the state of the lattice. Suppose that the lattice is in a pure state  $|\psi\rangle$ . (One obtains the same conclusion if one considers the lattice to be in a mixed state, or at a finite temperature.) Let  $|i\rangle, i=1, \dots, l$ , be a complete set of states of  $AA$  and  $|j\rangle, j=1, \dots, J$ , be the states of the rest of the lattice. We can write  $|\psi\rangle = \sum_{i,j} \psi_{ij} |i\rangle |j\rangle$ . We will assume for simplicity that  $\psi_{ij}$  is real. The reduced density matrix is [4]

$$\rho_{ii'} \equiv \sum_j \psi_{ij} \psi_{i'j}. \quad (2)$$

Let  $|u^\alpha\rangle, \alpha=1, \dots, m$ , with  $m < l$ , be the optimal set of states we seek. The most general expansion for  $\psi$  in terms of the  $|u^\alpha\rangle$  is

$$|\psi\rangle \approx \sum_{\alpha,j} a_{\alpha,j} |u^\alpha\rangle |j\rangle. \quad (3)$$

If we minimize the error in the representation of  $|\psi\rangle$ ,  $||\psi\rangle - \sum_{\alpha,j} a_{\alpha,j} |u^\alpha\rangle |j\rangle|$ , with respect to both  $a_{\alpha,j}$  and  $u_i^\alpha = \langle u^\alpha | i \rangle$  (with  $\langle u^\alpha | u^\alpha \rangle = \delta_{\alpha\alpha'}$ ), we find that the  $u^\alpha$  are the eigenvectors of  $\rho$  with the largest magnitude eigenvalues  $w_\alpha$ .

Each  $w_\alpha$  represents the probability of  $AA$  being in the state  $|u^\alpha\rangle$ , with  $\sum_{\alpha=1}^l w_\alpha = 1$ . The deviation of  $P_m \equiv \sum_{\alpha=1}^m w_\alpha$  from unity measures the accuracy of the truncation to  $m$  states.

Diagonalization of a superblock composed of  $p$  identical blocks, the configuration used in Ref. [2], is difficult for a many-particle system, since the dimension of the Hamiltonian is  $m^p$ , assuming  $m$  states per block. A better approach is shown in Fig. 1(b), where the superblock consists of two blocks and two sites. We adopt the notation  $A \cdot A$  for this form of lattice. In this case the

dimension of  $H$  is proportional to  $m^2$ . Here  $A'$  comes from a block plus a single site. [In a similar way, Wilson added a single interval (site) per iteration for the Kondo problem.] We found the configuration of Fig. 1(b) to be particularly efficient after trying a variety of alternative approaches. Note that open boundary conditions are used, since then the boundary between  $A$  and the rest of the system is a single point (as opposed to two points for periodic boundary conditions). In the limit of no connections between  $A$  and the rest of the system,  $P_m = 1$  for  $m=1$ . In general, the smaller this boundary, the faster  $P_m$  converges with  $m$  to unity. Note also that there are never any truncation errors from previous iterations in the representation of the two sites; this makes the iteration very stable.

The following are the steps of a single iteration of our density matrix approach in its most basic form: (1) Diagonalize the Hamiltonian of the system  $A \cdot A$  using a sparse matrix algorithm, extracting the ground state. (2) Use Eq. (3) to find  $\rho$  for  $A \cdot A$ . (3) Diagonalize  $\rho$  to find the *largest*  $m$  eigenvalues  $w_\alpha$  and associated eigenvectors  $u^\alpha$ . (4) Change basis and truncate using Eq. (1), with the  $u^\alpha$  forming the rows of  $O$ . (5) Replace the first block by  $A'$  and the last by the reflection of  $A'$ .

Note that while the method generates  $m$  states for a block, these states are optimized specifically for producing *one* "target" state of  $A \cdot A$  (although additional states can be targeted). For this reason, surprising accuracy is possible with very small  $m$ . However, only the target state is produced accurately.

At the fixed point of this iteration, the block  $A$  represents one-half of an infinite chain. Often it is useful to have results for a finite chain, but the above method (the infinite-system method) is not especially accurate in the early iterations. This is to be expected, since initially the density matrices used are derived from very small lattices. A variation on the method, which works very well for finite systems of size  $L$  ranging from four to several hundred sites, is illustrated in Fig. 1(c). The essential difference here is that the total length of the system  $A \cdot A$  is always  $L$  (after some initial iterations of the infinite-system method to initially reach size  $L$ ). This means that the first and last blocks are of different sizes, and one must keep track of a set of blocks of all sizes from 1 to  $L$ . We will explain this algorithm in detail in a subsequent paper. The calculation time is only 2 or 3 times as long as the time for the infinite-lattice method to reach size  $L$ .

As a test case for this approach, we have implemented it for antiferromagnetic Heisenberg spin chains, with  $S = \frac{1}{2}$  and  $S = 1$ , with Hamiltonian

$$H = \sum_i \mathbf{S}_i \cdot \mathbf{S}_{i+1}, \quad (4)$$

where we have set  $J=1$ . While the  $S = \frac{1}{2}$  case is soluble via the Bethe ansatz, the  $S=1$  case is not. The  $S=1$  chain has been the subject of considerable numerical

TABLE I. Ground-state energies per site of infinite  $S = \frac{1}{2}$  and  $S=1$  antiferromagnetic Heisenberg chains. The exact Bethe-ansatz result for the energy of the  $S = \frac{1}{2}$  chain is  $-\ln 2 + \frac{1}{4} = -0.443\,147\dots$ , and  $m$  is the number of states kept in block  $A$  (counting a triplet as three states, etc.). Results labeled  $\infty$  are obtained from a linear extrapolation to  $P_m \rightarrow 1$ . Monte Carlo results are taken from Refs. [7] and [5].

$m$	$S = \frac{1}{2}$ $E_0 - E_0^{\text{exact}}$	$S = \frac{1}{2}$ $1 - P_m$	$S=1$ $-E_0$	$S=1$ $1 - P_m$
16	$5.8 \times 10^{-5}$	$8.0 \times 10^{-6}$	1.401089	$4.8 \times 10^{-5}$
24	$1.7 \times 10^{-5}$	$1.9 \times 10^{-6}$	1.401380	$1.6 \times 10^{-5}$
36	$7.8 \times 10^{-6}$	$9.0 \times 10^{-7}$	1.401437	$6.6 \times 10^{-6}$
44	$3.2 \times 10^{-6}$	$3.6 \times 10^{-7}$	1.401476	$1.1 \times 10^{-6}$
$\infty$	$1.9 \times 10^{-7}$		1.401484(2)	
MC	$\sigma = 5 \times 10^{-4}$		1.4015(5)	

effort [5–8] since Haldane argued that the infinite system has a finite gap between the ground and first excited state [9]. Thus these two cases provide excellent tests both for the accuracy of the methods and for their competitiveness with other numerical approaches. Details of the numerical methods will be published elsewhere, as well as a more complete discussion of the results summarized below.

Table I shows results for the ground-state energies of the infinite  $S = \frac{1}{2}$  and  $S=1$  chains. The energy per site was determined from the difference in total energy of the system  $A \cdots A$  from one iteration to the next. The procedure was iterated until the energy converged to about eight digits, about 100 iterations for the  $S=1$  case.

We see from Table I that the method accurately recovers the exact energy of the  $S = \frac{1}{2}$  chain to almost six digits. The truncation error  $1 - P_m$  appears to be an excellent estimator for the errors in the results, and can even be used to extrapolate to the exact limit  $P_m \rightarrow 1$  to reduce errors further. Note the errors decrease roughly exponentially with  $m$ . The final result for the  $S=1$  ground-state energy appears to be more than 2 orders of magnitude more accurate than the best available from Monte Carlo calculations.

Results for the energies of 16 and 22 site blocks for  $S = \frac{1}{2}$  from the finite-lattice method are compared with exact diagonalization in Table II. This iterative diagonalization method is able to obtain energies for finite lattices with remarkable accuracy, even keeping only sixteen states. Results almost as accurate were obtained for  $S=1$  chains, where we compared our results with Kennedy's exact diagonalization [6].

Recently there has been considerable interest in the  $S = \frac{1}{2}$  degrees of freedom at the ends of finite, open  $S=1$  chains [6,10]. These effective spin- $\frac{1}{2}$ 's have been observed experimentally in NENP systems [10,11], and are also the subject of current theoretical study [12]. As noted by Kennedy [6], these spins bind weakly on a finite open chain to form a singlet ground state with a triplet

TABLE II. Relative errors  $(E - E_{\text{exact}})/E_{\text{exact}}$  in ground-state energies in the indicated spin sector  $S_T$  of finite  $S = \frac{1}{2}$  chains of length  $L=16$  and  $L=22$ . The exact energies were determined by a separate exact diagonalization. Truncation errors  $1 - P_m$  varied from about  $10^{-7}$  to  $10^{-9}$ . The  $L=22$ ,  $m=24$  calculation took about 20 s of Cray time.

$m$	$L=16$ $S_T=0$	$L=16$ $S_T=1$	$L=16$ $S_T=2$	$L=22$ $S_T=0$
16	$9.3 \times 10^{-8}$	$1.2 \times 10^{-7}$	$5.9 \times 10^{-8}$	$8.0 \times 10^{-7}$
24	$2.2 \times 10^{-9}$	$5.4 \times 10^{-9}$	$4.0 \times 10^{-9}$	$8.1 \times 10^{-8}$

just above it (for an even numbered chain). In order to see the Haldane gap with open boundary conditions, one must look at the first excited state above this triplet. We find that the next excited state has total spin  $S_T=2$ , a quintuplet, and we define the Haldane gap for system size  $L$ ,  $\Delta_L$ , as the gap between the lowest-lying  $S_T=2$  and  $S_T=1$  states.

Figure 2 shows the Haldane gap  $\Delta_L$  for lattice sizes ranging from 40 to 300 using the finite-lattice method, using  $m=40$  and  $m=50$  and extrapolating to  $P_m \rightarrow 1$ . The data are fitted by the form

$$\Delta_L = \Delta + a/L^2 \quad (5)$$

quite well, with  $\Delta=0.4107(3)$  and  $a=67.9$ . Nightingale and Blöte obtained  $\Delta \approx 0.41$  by extrapolating Monte Carlo results for chains up to  $L=32$ .

Because the two  $S = \frac{1}{2}$  degrees of freedom at the ends of an  $S=1$  chain always bind to form the singlet and triplet discussed above, they are usually not directly observed numerically [6]. An interesting way to see a single  $S = \frac{1}{2}$  effective spin is to attach a *real*  $S = \frac{1}{2}$  spin onto one end of a finite  $S=1$  chain. The ground state of this system is a spin doublet. Figure 3 shows the expectation value of  $S_i^z$  as a function of lattice site  $i$  for a sixty-site chain for the  $S_i^z = +\frac{1}{2}$  ground state. The  $S = \frac{1}{2}$  degree of freedom manifests itself at the *opposite end* of the

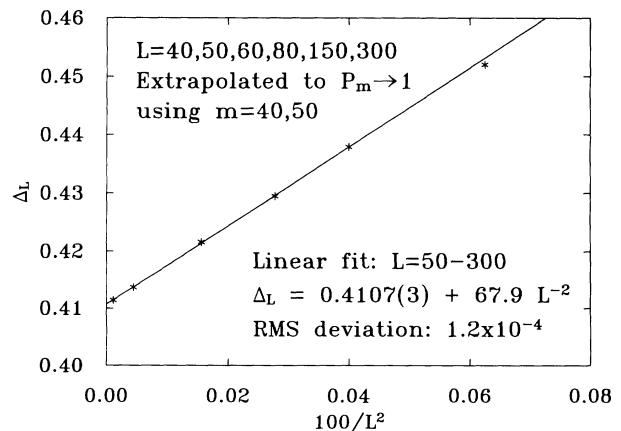

FIG. 2. The Haldane gap as a function of lattice size  $L$ .

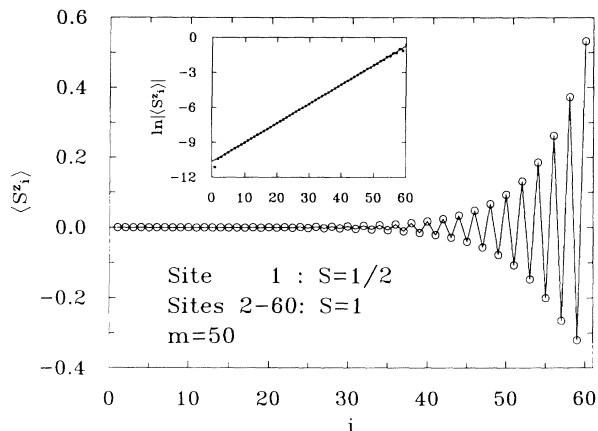

FIG. 3. Expectation value of  $S_i^z$  as a function of  $i$  for a sixty-site chain with the first site  $S = \frac{1}{2}$  and all the rest  $S = 1$ .

chain from the real  $S = \frac{1}{2}$  spin. The value of  $S_i^z$  on the last site is 0.532(1), slightly larger than  $\frac{1}{2}$ , the result for a real  $S = \frac{1}{2}$  spin, but less than the Schwinger-boson mean-field result of 0.7 [12]. We also show  $\ln|S_i^z|$ , which is extremely linear away from the ends, indicating almost pure exponential decay. The straight line is a linear fit to the data from 20 to 40, from which we obtain a decay length of  $\xi = 6.03(1)$ . This result is quite close to the recent Monte Carlo result of 6.2(1) for the correlation length obtained using the two-point spin-spin correlation function [7,8]. We plan further studies of the spin-spin correlation function to determine if the decay length and correlation length are, in fact, identical.

Using this new formulation of numerical renormalization groups and iterative diagonalization, we have been able to calculate several of the most interesting properties of  $S = 1$  Heisenberg chains with an accuracy not achievable with other methods on today's computers. We have no reason to believe that other 1D lattice systems with short-range interactions will be substantially more difficult. This new formulation appears extremely powerful and versatile, and we believe it will become the leading

numerical method for 1D systems, and eventually will become useful for higher dimensions as well.

We would like to thank R. Noack, D. Huse, C. Yu, I. Dzyaloshinski, M. P. Gelfand, D. Mills, and L. Nosanow for helpful comments and discussion. This work was supported by the Office of Naval Research under Grant No. N00014-91-J-1143 and in part by the University of California through an allocation of computer time on the UC Irvine Convex. Calculations were also performed at SDSC.

- [1] K. G. Wilson, Rev. Mod. Phys. **47**, 773 (1975).
- [2] S. R. White and R. M. Noack, Phys. Rev. Lett. **68**, 3487 (1992).
- [3] Knowledge of  $H_A$  alone is not sufficient to form the block Hamiltonian at the next iteration. In addition, one needs information on how to form the interaction between two blocks. One needs, in addition to  $H_A$ ,  $m \times m$  matrices representing (for spin models) matrix elements of  $S_i^z$ ,  $S_i^+$ , and  $S_i^-$ , for the two sites  $i$  on the edges of a block. Using the spin operator matrices for the right-hand site  $i$  of the left block and the left-hand site  $i+1$  of the right block, one can easily reconstruct the interaction  $\mathbf{S}_i \cdot \mathbf{S}_{i+1}$  between the blocks. These operator matrices are treated in the same fashion as the Hamiltonian, using an analog of Eq. (1), for example.
- [4] R. P. Feynman, *Statistical Mechanics: A Set of Lectures* (Benjamin, Reading, MA, 1972).
- [5] M. P. Nightingale and H. W. J. Blöte, Phys. Rev. B **33**, 659 (1986).
- [6] T. Kennedy, J. Phys. Condens. Matter **2**, 5737 (1990).
- [7] S. Liang, Phys. Rev. Lett. **64**, 1597 (1990).
- [8] K. Nomura, Phys. Rev. B **40**, 2421 (1989).
- [9] F. D. M. Haldane, Phys. Lett. **93A**, 464 (1983).
- [10] M. Hagiwara, K. Katsumata, I. Affleck, B. I. Halperin, and J. P. Renard, Phys. Rev. Lett. **65**, 3181 (1990).
- [11] S. H. Glarum, S. Geschwind, K. M. Lee, M. L. Kaplan, and J. Michel, Phys. Rev. Lett. **67**, 1614 (1991).
- [12] T. K. Ng, Phys. Rev. B **45**, 8181 (1992).