

Measurement of the Spontaneous Polar Kerr Effect in $\text{YBa}_2\text{Cu}_3\text{O}_7$ and $\text{Bi}_2\text{Sr}_2\text{CaCu}_2\text{O}_8$

S. Spielman, J. S. Dodge, L. W. Lombardo, C. B. Eom, M. M. Fejer, T. H. Geballe, and A. Kapitulnik

Department of Applied Physics, Stanford University, Stanford, California 94305

(Received 31 December 1991)

The existence of spontaneous polar Kerr rotation in $\text{Bi}_2\text{Sr}_2\text{CaCu}_2\text{O}_8$ single crystals and $\text{YBa}_2\text{Cu}_3\text{O}_7$ thin films was tested using a Sagnac interferometer. Observation of this effect would be strong evidence that the superconductivity in the cuprates is described by a theory that predicts broken time-reversal symmetry. The Kerr effect was analyzed for both a spatially fluctuating component (anticipating domains) and absolute offset. Neither effect was observed within the sensitivity of the apparatus. The drift of the apparatus sets an upper limit for the offset component at $10 \mu\text{rad}$. The noise places an upper limit of $3 \mu\text{rad}$ on the standard deviation of the spatial fluctuation of the effect.

PACS numbers: 74.65.+n

Since the discovery of the cuprate superconductors, there has been much effort to explain their behavior. The planar geometry of the cuprates has led to investigations of model systems whose behavior is dominated by two-dimensional (2D) anisotropy. In particular, it has been proposed that the 2D Hubbard model can lead to a state that breaks two-dimensional parity (P) and time-reversal (T) symmetry [1]. This state has excitations which obey fractional statistics. Although in three dimensions particles must behave as either bosons or fermions, in 2D it is possible to have particles, called "anyons," whose properties are intermediate between these limiting cases. It has been predicted that a gas of anyons will form a superconductor [2,3]. One expects P and T symmetry to be broken spontaneously in an anyon superconductor for temperatures below a critical value T_{TP} , equal to or larger than the superconducting transition temperature, T_c [4].

It was first suggested by Wen and Zee [5] that the broken symmetry in an anyon superconductor could be observed optically. A familiar example of spontaneously broken P and T symmetries is a ferromagnet cooled below its Curie temperature. The broken symmetry is observable in the form of the polar Kerr effect in reflection and the Faraday effect in transmission. Several attempts have been made to observe these effects in the high- T_c cuprate superconductors, but experimental results to date have not been conclusive. Spielman *et al.* have reported null results in transmission on $\text{YBa}_2\text{Cu}_3\text{O}_7$ [6] and $\text{Bi}_2\text{Sr}_2\text{CaCu}_2\text{O}_8$ [7]. Lyons *et al.* [8] at AT&T and Weber *et al.* [9] at Dortmund have reported positive results in reflection and transmission on similar samples. Even the two positive results differ so much in magnitude as to be irreconcilable.

The motivation for the present experiment is to resolve the discrepancies in these previous results. Our aim is to better duplicate the conditions in the experiments that yield positive results, while still retaining the fundamental advantages offered by the Sagnac interferometer technique. Originally it was believed that the wavelength of the probe radiation was the crucial difference. The null result in [6] was made at 1060 nm, whereas 515 nm was used at AT&T and 632 nm at Dortmund. However, the

null results obtained for high-quality $\text{Bi}_2\text{Sr}_2\text{CaCu}_2\text{O}_8$ crystals with a new interferometer operating at 670 nm [7] suggest that the wavelength difference may not account for the discrepancy.

Another difference between the experiments was that while there were positive results from reflection measurements, all of the Sagnac interferometer measurements had been done in transmission. A transmission configuration measures the Faraday effect, which is a symmetry breaking in the real part of the index of refraction n , whereas a reflection configuration measures the Kerr effect, which is sensitive to both the real and imaginary parts, n and k . Based on the known optical constants of $\text{YBa}_2\text{Cu}_3\text{O}_7$ and $\text{Bi}_2\text{Sr}_2\text{CaCu}_2\text{O}_8$, it can be shown that it is unlikely that the symmetry breaking would appear only in k . However, there is another scenario, suggested by Dzyaloshinskii [10], in which the symmetry breaking would be observable only in reflection. If the sign of the T breaking alternates between conducting planes ("antiferromagnetic" or "AF" ordering) the Faraday effect would cancel in transmission. In reflection, his symmetry argument predicts that the magneto-optic effect will *not* cancel out if the magnetic unit cell equals the crystallographic unit cell. For example, in $\text{Bi}_2\text{Sr}_2\text{CaCu}_2\text{O}_8$ and $\text{YBa}_2\text{Cu}_3\text{O}_7$ where there are two conduction planes per unit cell, switching the handedness of all the planes produces a distinguishable state, as shown in Fig. 1. Even if

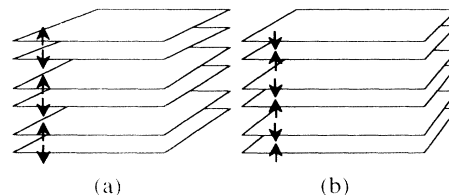

FIG. 1. Two possible configurations for antiferromagnetically (AF) ordered conduction planes are shown. Because the crystallographic unit cell is equal to the AF unit cell, the time-reversed picture (b) cannot be made to look identical to (a) by a simple lattice transformation. Thus, the two states are distinguishable.

the planes order AF, the T -reversed picture cannot be made to look like the original by a simple lattice translation. Dzyaloshinskii predicts that T breaking in a two-layer system would result in a reflection signal comparable to that of a single layer in transmission.

It is important to note that this argument is based on symmetry and thus applies only to a sample with inversion symmetry. A thin film does not have this symmetry because the vacuum-film interface differs from the substrate-film interface. Therefore, we would have expected an effect on the order of that from a single layer in transmission through a $\text{YBa}_2\text{Cu}_3\text{O}_7$ thin film [6], though possibly not in the free-standing $\text{Bi}_2\text{Sr}_2\text{CaCu}_2\text{O}_8$ crystals [7]. Nevertheless, we have addressed this point by applying the Sagnac interferometer technique in reflection to measure the polar Kerr rotation.

The rotation of linearly polarized light known as the Kerr effect occurs because the left- and right-circular components (RCP and LCP) acquire a difference in phase ϕ upon reflection. In general, there will be a difference in the magnitude of the reflected components as well, resulting in an elliptically polarized beam. At the sample surface, RCP and LCP are equivalent except that the electric field vectors have opposite time dependence. Because a magnetic sample is not T preserving, it is possible for these two components to propagate differently, and hence produce an observable optical effect. However, detecting the Kerr effect by analyzing the polarization state is made difficult by birefringence and linear dichroism in the sample. Although these phenomena are T preserving, they can affect the polarization state of the light, because they couple RCP to LCP radiation and vice versa. We have used a method in which ϕ is measured directly. Two beams are incident on the sample, one RCP and one LCP, and the difference in phase shift they

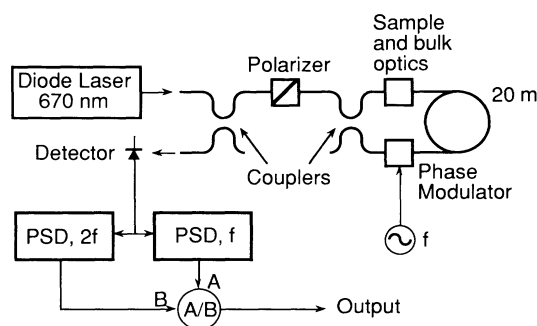

FIG. 2. Shown here is the optical circuit. Light exiting from the polarizer is split by the second coupler into two beams which traverse the loop in opposite directions. Unless T is broken in the loop, the beams interfere constructively when they recombine. As the phase modulator dithers this interference about the maximum, primarily even harmonics of f are produced in the intensity. The odd harmonics are proportional to the (dc) phase shift from the sample. The photodiode signal is analyzed by phase sensitive detectors (PSD). The normalization shown corrects the output signal for throughput variations.

acquire is measured by a Sagnac interferometer. Birefringence and dichroism couple some light into the other (circular) polarization state, but this component is later blocked by a polarizer.

To search for broken T symmetry we have used a fiber-optic Sagnac interferometer as described in Ref. [6], in a configuration similar to Ref. [7]. The Sagnac interferometer circuit is shown in Fig. 2. Light from a 670-nm laser diode is launched into single-mode, polarization-maintaining optical fiber. After the light has passed through the polarizer and is launched again into fiber, it is purely single mode spatially, and the polarization state is pure to within the limitations of the polarizer. The light is split into two beams by the loop coupler. These two beams propagate in opposite directions around the loop, which contains the sample. If the loop is a reciprocal path, i.e., if its optical length does not depend upon the direction of propagation, then the two beams will return to the loop coupler precisely in phase and the maximum possible intensity will return through the polarizer and eventually to the detector. If the loop is nonreciprocal, the two beams acquire a phase difference ϕ , and the intensity will reduce to a fraction $[1 + \cos(\phi)]/2$ of the maximum. To enable the measurement of ϕ to μrad sensitivity, the system is actively biased by a phase modulator in the loop. The modulator is operated at a frequency f (approximately 5 MHz) which corresponds to twice the optical transit time of the 20-m loop. The sinusoidal phase shifts induced on the two beams by the modulator are equal and opposite since they pass through the modulator at times separated by half the modulator period. To first order in ϕ the signal from the detector will contain even harmonics of f proportional to the throughput of the loop, and odd harmonics proportional to ϕ , the quantity of interest [11]. The signal is analyzed with lock-in amplifiers as shown in Fig. 2. The drift of the system is approximately $10 \mu\text{rad}$, varying on a 30-min time scale.

The bulk optics portion of the loop, which contains the sample, is shown in Fig. 3. The light in both fibers is linearly polarized in the state determined by the polarizer in Fig. 2. The fiber ends are oriented so that one beam is

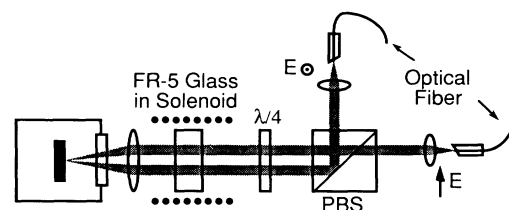

FIG. 3. These bulk optics are inserted into the Sagnac loop. The polarizing beam splitter (PBS) serves to route the beams so that a single quarter-wave plate and sample lens can be used. The right- and left-circularly polarized beams are nearly normally incident on the sample. The FR-5 glass (terbium borosilicate) in a solenoid produces a known Faraday rotation for calibration.

polarized in the plane of the page, the other out. This allows the use of a single quarter-wave ($\lambda/4$) plate, oriented at $\pm 45^\circ$ to the two polarizations, to produce the RCP and LCP incident on the sample. It is important to note that a small error in the retardance or orientation of the $\lambda/4$ plate results in reduced throughput of the apparatus but does not otherwise affect the measurement. The polarizing beam splitter (PBS) serves as a convenient means of steering one of the beams while leaving the other unaffected. The beams then propagate parallel to one another, separated by about 5 mm, and focus at the same point on the sample. If we use a fixed-coordinate system to describe the polarization states, the RCP beam reflects as RCP and along the path of the incoming LCP beam (and similarly for the LCP beam). Passing again through the $\lambda/4$ plate the beam returns to a linear polarization rotated 90° from its original orientation, so that it enters the fiber with the same polarization as the counter-propagating beam. The PBS- $\lambda/4$ pair also helps prevent scattered light from returning back into the fiber from which it came. Such backscattering, combined with residual amplitude modulation in the phase modulator, can cause a spurious signal. Spurious birefringence from the sample and $\lambda/4$ plate causes the isolation to be incomplete even for specularly reflected beams. For this reason, the collimated beams have been separated, as shown, trading perfectly normal incidence for reduced drift. The angle of incidence of each beam is approximately 3° .

When searching for small nonreciprocal effects with a Sagnac interferometer, it is essential that there exists only one optical path in the loop. This is accomplished by the use of single-mode optical fiber. The bulk components comprising the sample space can, of course, carry many spatial modes. However, once it has passed through the bulk optics, the light must couple back into a fiber to resume traversing the loop. This constraint acts on both (counterpropagating) beams to insure that they follow the same path. If there is scattering or misalignment in the optics, only the portion of the beam remaining in the correct spatial mode will return to the fiber. The mismatch produces no spurious signal, just a loss of throughput.

Since the domains of broken T are presumably smaller than the spot size, the spatial resolving power of the apparatus is an important quantity to consider. Since the spot is an image of the optical mode propagating in the fiber, its profile is nearly Gaussian. The e^{-2} radius w is 9 μm , measured by translating a mirror or sample edge across the beam and monitoring the throughput of the interferometer. The spatial frequency response of the system falls to $1/e$ at a frequency of $f_c \approx 1/2w$, and decreases as $\exp[-(2wf_c)^2]$. Therefore, a domain pattern containing *only* frequencies above f_c , for example, a structure periodic in the plane of the sample with a frequency $f > f_c$, would produce little or no fluctuation as the beam is scanned. However, it is unlikely that the anionic domains would order periodically [4]. In the case

of a thin film, it is more likely that each grain will "choose" the sign of its chirality randomly. The resulting random patchwork would have no lower cutoff in spatial frequency.

The spatial filtering provided by the single-mode fiber requires that the sample, like the other components, be aligned precisely, both in angle and focus. Thermal expansion and other disturbances make this alignment difficult to maintain, especially if the sample holder is fixed to the cold finger. In the case of $\text{Bi}_2\text{Sr}_2\text{CaCu}_2\text{O}_8$ crystals, which have rippled surfaces, this difficulty renders the experiment virtually impossible. To overcome this problem, the sample rotation and translation have been decoupled from each other and from the motion of the cold finger. The sample holder is mounted mechanically via a thin wall stainless-steel tube to a pair of goniometers outside the cryostat vacuum. These provide two rotation axes in the plane of the sample. The goniometers are attached to the vacuum shroud with a flexible bellows. The sample holder is thermally grounded to the cold head with a flexible bundle of copper strands. This configuration allows the sample to be translated and tilted with five nearly decoupled degrees of freedom, while being isolated from the motion in the cryostat pump line and transfer tube. Samples were mounted with thermal grease to the sample holder. A Pt thin film thermometer mounted on the sample holder read within 15 K of the cold finger temperature after equilibrium was reached. Laser power incident on the sample was 60 μW .

As a test of the apparatus, we examined the ferromagnetic phase transition of a Gd film, and compared our results to previous magneto-optic data [12]. The 430- \AA film was deposited by electron beam evaporation onto an MgO substrate. Because of the demagnetization factor, it is energetically favorable for the magnetism to form domains which lie in the plane of the film, producing no polar Kerr effect. By applying a perpendicular field of 70 G (about 0.035 of the saturation magnetization $M_{\text{sat}} \approx 2000$ G) we can tilt the magnetization of these domains out of the plane to produce a small polar Kerr effect as shown in Fig. 4. Well below the Curie temperature, $T_C \approx 290$ K, the measured phase shift is constant except for the drift of the apparatus, and the magnitude is about 0.030 of the saturated Kerr effect for Gd ($\phi_{\text{sat}} \approx 1500$ μrad). Above T_C the signal rapidly decreases. Assuming a Curie-Weiss dependence with a moment of 8 Bohr magnetons per Gd, the susceptibility is

$$\frac{\partial M}{\partial H} = \frac{1}{3} \frac{N}{V} (8\mu_B)^2 \frac{1}{k_B(T - T_C)}.$$

At even 5 K above T_C , the magnetization induced by 70-G applied field is only 6 G. Given the magneto-optic properties of Gd, the resulting phase shift would be on the order of 4 μrad , which is less than our drift.

Two $\text{Bi}_2\text{Sr}_2\text{CaCu}_2\text{O}_8$ single crystals were studied, as well as two $\text{YBa}_2\text{Cu}_3\text{O}_7$ films. The $\text{Bi}_2\text{Sr}_2\text{CaCu}_2\text{O}_8$ crys-

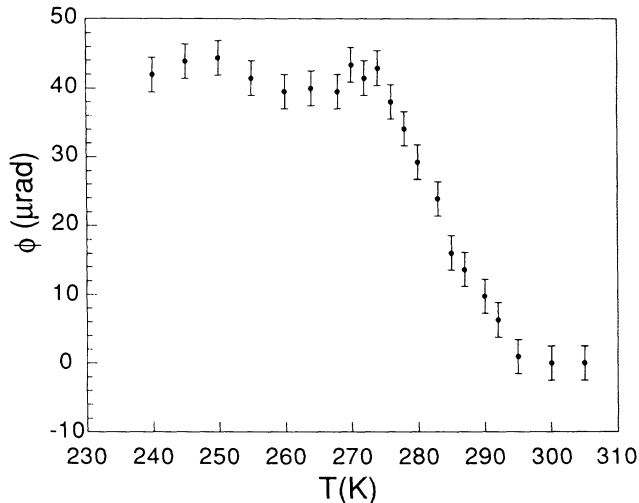

FIG. 4. Polar Kerr effect from a Gd thin film. The 430-Å film was cooled through its 293-K Curie temperature, in a 70-G applied field. Because of the demagnetization factor, the domains magnetize in the plane of the material, but the applied field rotates the moment of these domains so that they have a perpendicular component. A 5- μrad drift due to imperfections in the apparatus is apparent well below the Curie temperature.

tals were grown from a nearly stoichiometric melt in a strong thermal gradient using a magnesia crucible. Details of the crystal growth method are reported elsewhere [13]. Magnetometry on similar samples from the same melt indicated a superconducting transition at $T_c = 85$ K. The $\text{YBa}_2\text{Cu}_3\text{O}_7$ films were grown by single-target off-axis sputtering [14]. The films were 200 and 800 Å thick, and had transition temperatures of ~ 85 K, measured by four-point resistivity.

Samples were placed in the Sagnac loop as described and cooled to temperatures as low as 25 K. At each temperature, the beam was moved to several points on the sample surface and the nonreciprocal signal ϕ was measured. A variance in the values of ϕ would indicate a random domain structure exists, whereas a constant offset would indicate a single chirality of the anyon state over the sample surface. Both quantities were measured to be zero to within the sensitivity of our apparatus. The upper limit on offset is set by the drift in the apparatus, 10 μrad . The variance measurements can be performed on a shorter time scale than that of the drift, allowing us to place an upper limit of 3 μrad on the variance σ_ϕ .

In conclusion, we present new results on the search for broken T symmetry in the high- T_c superconductors. Despite the symmetry argument that predicts the possi-

bility of an observed magneto-optic effect in reflection where there had been none in transmission, we observed no spontaneous Kerr effect within the resolution of the apparatus. The finding does not disprove the role of anyons in these materials, but rather implies that if they do exist, they yield very weak optical effects at this wavelength. Possibly the signal is much reduced by inter-plane antiferromagnetic ordering or the in-plane domain structure is not random as assumed, but possesses only high spatial frequency components.

Useful discussions with Taylor Lawrence are gratefully acknowledged. This work was supported by the National Science Foundation through the PYI program (A.K.), by AFOSR Grant No. 91-0145 (S.S.), and by Stanford University through the Office of Technology Licensing. $\text{Bi}_2\text{Sr}_2\text{CaCu}_2\text{O}_8$ crystals were made with support from the Stanford Center for Materials Research through the MRL/NSF program.

- [1] X. G. Wen, F. Wilczek, and A. Zee, *Phys. Rev. B* **39**, 11413 (1989).
- [2] V. Kalmeyer and R. B. Laughlin, *Phys. Rev. Lett.* **59**, 2095 (1987).
- [3] R. B. Laughlin, *Science* **242**, 525 (1988).
- [4] B. I. Halperin, J. March-Russel, and F. Wilczek, *Phys. Rev. B* **40**, 8726 (1989).
- [5] X. G. Wen and A. Zee, *Phys. Rev. Lett.* **62**, 2873 (1989).
- [6] S. Spielman, K. Fesler, C. B. Eom, T. H. Geballe, M. M. Fejer, and A. Kapitulnik, *Phys. Rev. Lett.* **65**, 123 (1990).
- [7] S. Spielman, J. S. Dodge, K. Fesler, L. W. Lombardo, M. M. Fejer, T. H. Geballe, and A. Kapitulnik, *Phys. Rev. B* **45**, 3149 (1992).
- [8] K. B. Lyons, J. Kwo, J. F. Dillon, Jr., G. P. Espinosa, M. A. P. Ramirez, and L. F. Schneemeyer, *Phys. Rev. Lett.* **64**, 2949 (1990).
- [9] W. W. Weber, D. Weitbrecht, D. Brach, H. Keiter, A. L. Shelankov, W. Weber, Th. Wolf, J. Geerk, G. Linker, G. Roth, P. C. Splittgerber-Hünnekes, and G. Güntherodt, *Solid State Commun.* **76**, 511 (1990).
- [10] I. E. Dzyaloshinskii, in *Proceedings of the TCSUH Workshop on the Physics and Mathematics of Anyons* (World Scientific, Singapore, 1991).
- [11] See, e.g., papers in *Fiber-Optic Rotation Sensors and Related Technologies*, edited by S. Ezekiel and H. J. Arditty (Springer-Verlag, Berlin, Heidelberg, New York, 1982).
- [12] J. L. Erskine and E. A. Stern, *Phys. Rev. B* **8**, 1239 (1973).
- [13] L. W. Lombardo and A. Kapitulnik (to be published).
- [14] C. B. Eom, J. Z. Sun, K. Y. Yamamoto, A. F. Marshall, K. E. Luther, and T. H. Geballe, *Appl. Phys. Lett.* **55**, 595 (1989).

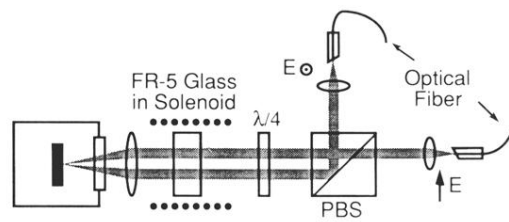

FIG. 3. These bulk optics are inserted into the Sagnac loop. The polarizing beam splitter (PBS) serves to route the beams so that a single quarter-wave plate and sample lens can be used. The right- and left-circularly polarized beams are nearly normally incident on the sample. The FR-5 glass (terbium borosilicate) in a solenoid produces a known Faraday rotation for calibration.