

## Displacement Distribution and Atomic Jump Direction in Diffusion of Ir Atoms on the Ir(001) Surface

Chonglin Chen and Tien T. Tsong

*Physics Department, The Pennsylvania State University, University Park, Pennsylvania 16802*

(Received 30 March 1990)

On the Ir{001} surface an Ir adatom is surprisingly found to jump along the  $\langle 001 \rangle$  direction instead of along the smoother closely packed  $\langle 110 \rangle$  atomic channel of the substrate, probably by an atomic exchange mechanism. The sites visited by one diffusing adatom therefore form a  $c(2 \times 2)$  net of the substrate lattice. The displacement distributions derived are consistent with those expected from a discrete random walk with the atomic jump length of the nearest-neighbor distance of the  $c(2 \times 2)$  net.

PACS numbers: 68.35.Fx, 61.50.Cj, 68.35.Md

The transport of atoms on a surface is achieved by random-walk diffusion of single atoms and possibly also of small atomic clusters. One of the subjects of great current interest is how an adsorbed atom, or adatom, moves or jumps on the surface. In general, one can expect an adatom to jump along the surface channel direction of the least corrugation height based on the hard-sphere model of the surface. In fact, most experimental data are consistent with this assumption.<sup>1</sup> As far as we are aware, there are few exceptions to this rule. An exception is that on the fcc  $\langle 110 \rangle$  surface of some metals, an adatom can jump either along the surface channel direction or over the surface channel by an exchange diffusion.<sup>2</sup> A recent theoretical calculation by Feibelman<sup>3</sup> concludes that it is energetically favorable to have an Al adatom on the Al{001} surface displace along the  $\langle 001 \rangle$  direction by an exchange diffusion of the adatom with a substrate atom instead of displacing along the smoother  $\langle 110 \rangle$  surface channel direction by atomic hopping. His argument is that Al atom has the valency of three. If an Al adatom moves in the  $\langle 001 \rangle$  direction, one of the lattice Al atoms will be displaced upward and move together with the adatom. In such a concerted motion of two Al atoms, during the transition each of them will have three chemical bonds formed, two with substrate Al atoms and one with the other jumping atom. Thus such a mode of diffusion is energetically favored. He further argues that as a result of this form of exchange diffusion, the surface sites visited by the diffusing atom will form a  $c(2 \times 2)$  net of the substrate lattice. Although decent field-ion-microscopic (FIM) images of aluminum can be obtained,<sup>4</sup> it is very unlikely that detailed atomic steps in the surface diffusion of single atoms can be studied for this metal. This is because the evaporation field of Al is too low to allow a good image resolution of the FIM and, in addition, the surface is too unstable for a lengthy measurement. We present here an FIM study of the atomic jump direction in random-walk diffusion of an Ir adatom on the Ir{001} surface by a measurement of both the two-dimensional displacement

distribution and the structure of the surface net visited by one diffusion adatom.

Techniques and procedures for studying the behavior of single atoms and small atomic clusters on metal surfaces using the FIM are now very well developed.<sup>1</sup> They can be found in the literature and will not be described in detail here. In this study, we pay great attention to the thorough degassing of the Ir field-ion emitter and the Ir deposition coil source. An Ir tip, spot welded on a 5-mil Pt loop with two 1-mil Pt potential leads, is first degassed around 1000 K for many hours in the background pressure of the FIM which is below the x-ray limit of the ionization gauge, or below  $2 \times 10^{-11}$  Torr, and is then field evaporated at  $\sim 25$  K, the imaging temperature of the FIM. The Ir deposition coil is degassed repeatedly near the melting point in the same background vacuum. We use exclusively Vycor-glass-diffused He from a research-grade He bottle for the FIM imaging. Tip heating is done by an electronically controlled pulsed power supply which can heat the tip to the final tempera-

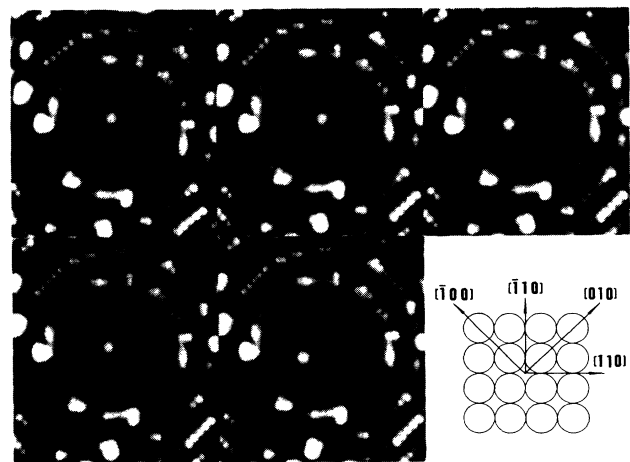

FIG. 1. A few field-ion images showing random-walk diffusion of one Ir atom on an Ir(001) surface.

ture in less than 0.2 s without overshoot. Unless explicitly stated, each heating period is 20 s. It has been shown earlier that displacements of an adatom as well as the structure of the surface net of the substrate can be mapped with a resolution of  $\sim \pm 0.5 \text{ \AA}$  by using internal or external fiducial marks.<sup>5</sup> Using an image digitizing technique with a personal computer, it is now possible to achieve a spatial resolution of  $\sim \pm 0.3 \text{ \AA}$  in the image mapping provided that the image voltage is kept constant.

To avoid the complication of the effect of the plane edges, all our data on displacement distributions are taken with an adatom far away from the plane edge. The (001) plane edge does not reflect Ir adatoms. When a diffusion adatom encounters a plane edge it usually falls down the step and is lost from the top surface layer and a new adatom will have to be deposited on the surface. Figure 1 shows a few field-ion images of a diffusing Ir adatom on an Ir(001) surface, and Fig. 2 shows an Arrhenius plot for surface diffusion of one Ir atom on the Ir(001) surface. The activation energy  $E_d$  found is  $0.84 \pm 0.05 \text{ eV}$ , and the diffusivity  $D_0$  found is  $6.3 \times (11) \pm 1 \times 10^{-2} \text{ cm}^2/\text{s}$ .

The purpose of our present experiment is to find out the atomic jump directions and the length of each atomic jump. An earlier study<sup>6</sup> has shown that this information can be derived by measuring the two-dimensional displacement distribution of an adatom taken under the condition of having a very small mean-square displacement in a heating period, i.e., under the condition that only one atomic jump is found for every few heating periods of observation. When the heating temperature is set at 257.5 K with heating periods of 20 s each, the surface net visited by one Ir adatom on an Ir(001) surface shown in Fig. 3(a) is obtained. Within the spatial resolution of the image digitizer, the adatom position may fall into the same spot repeatedly. Figure 3(b) shows the number of times the adatom is found in each of the visit-

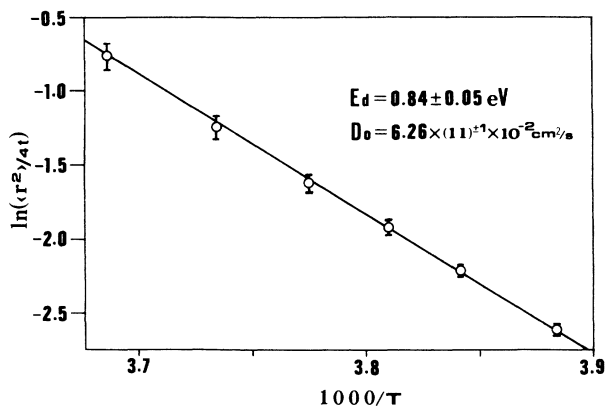

FIG. 2. The logarithm of the mean-square displacement as a function of the inverse temperature derived with an Ir atom on the Ir(001) surface.

ed sites. It is clear that the net of the visited sites by the diffusing atom indeed forms a  $c(2 \times 2)$  net of the substrate lattice; this lattice is shown by the bold lines. On the fcc (001) surface, all surface sites are equivalent to one another. From the fourfold symmetry of the visited-site net, one can also conclude that the adsorption sites can only be either the fourfold hollow sites or the fourfold atop sites. A calculation shows that the adsorption sites should be the fourfold hollow sites.<sup>7</sup> For a metal adatom, adsorption on an atop site is highly unlikely. Our data are consistent with the fourfold-hollow-site adsorption. For the fourfold-hollow-site adsorption, the  $(1 \times 1)$  net can be considered to be formed by two inter-

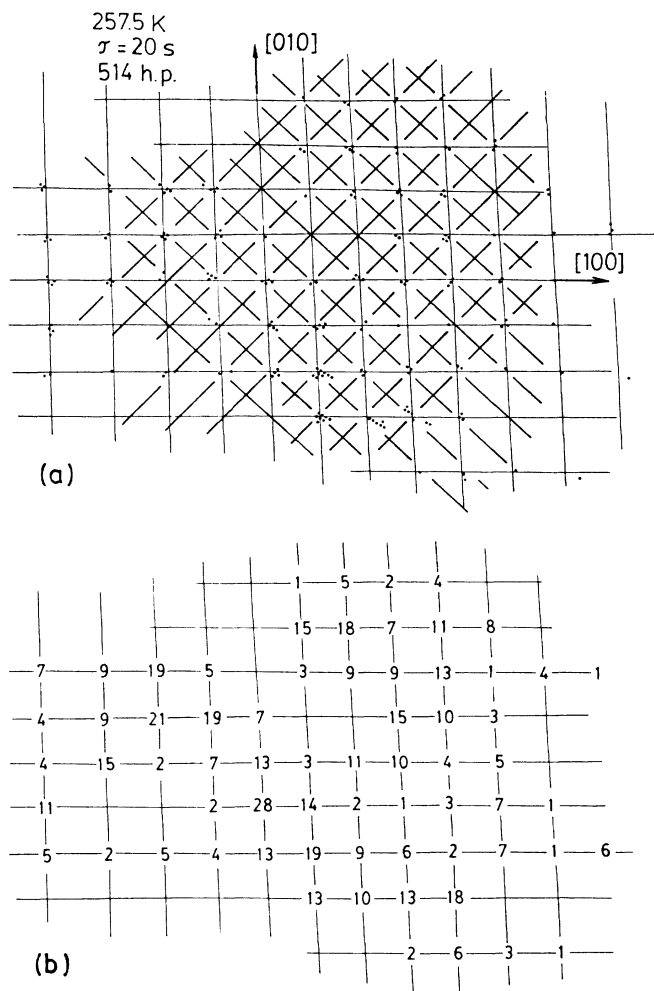

FIG. 3. (a) The sites visited by one Ir atom on an Ir(001) surface. These sites form a  $c(2 \times 2)$  net, shown by the thin lines, of the substrate lattice which is shown by the bold lines. A total of 514 heating periods of observations are made at 257.5 K with heating periods of 20 s each. The sequence of these atomic displacements and the length and direction of each displacement are also derived, but are not shown in the figures. (b) The frequencies of occupation of these sites by the Ir atom.

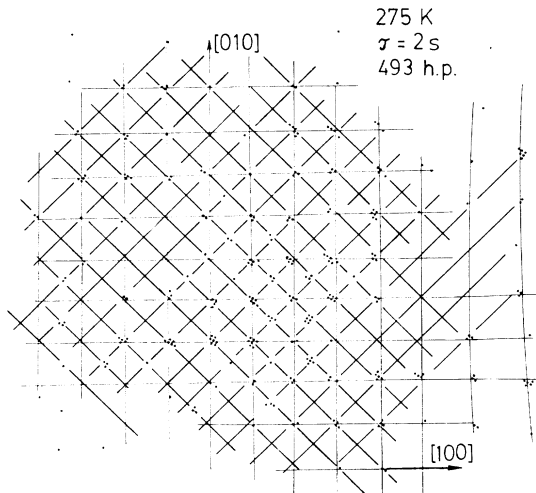

FIG. 4. The surface net of sites visited by 8 Ir atoms on an Ir(001) surface (only one atom is on the surface at a time) at 275 K. The net of the visited sites forms a  $(1 \times 1)$  structure of the substrate.

penetrating  $c(2 \times 2)$  nets. Thus if a net of the visited sites is obtained by combining the visited sites of several adatoms, but deposited one at a time, then a  $(1 \times 1)$  net will be obtained. Figure 4 combines the visited sites of

eight separately deposited Ir adatoms, one at a time, on the same Ir(001) surface. These data are collected at 275 K with heating periods of 2 s each. Although the visited sites of several single Ir adatoms form a  $(1 \times 1)$  net of the substrate lattice, no single atomic jump along the  $\langle 110 \rangle$  direction has ever been observed.

The 2D displacement distributions measured at a few temperatures are shown in Fig. 5 together with theoretical distributions calculated from the mean-square displacements based on a discrete random walk of nearest-neighbor atomic jumps,<sup>8</sup> that is, the length of each atomic jump is one lattice parameter along the  $\langle 001 \rangle$  direction, or 3.84 Å of the Ir lattice. In these distributions, we have combined data from all the equivalent displacements so that the statistical uncertainty of each data point can be minimized. It is clear that the experimental distributions all agree within statistical uncertainties with the theoretical distributions. We therefore conclude that in the temperature range of the measurements, Ir adatoms diffuse on the Ir{001} surface by a discrete nearest-neighbor [of the  $c(2 \times 2)$  net of the substrate lattice] random walk along the  $\langle 001 \rangle$  direction.

There are two possible mechanisms which can produce atomic jumps consistent with our observation. These mechanisms are illustrated in Fig. 6. Figures 6(a)–6(c) show an exchange diffusion proposed by Feibelman for

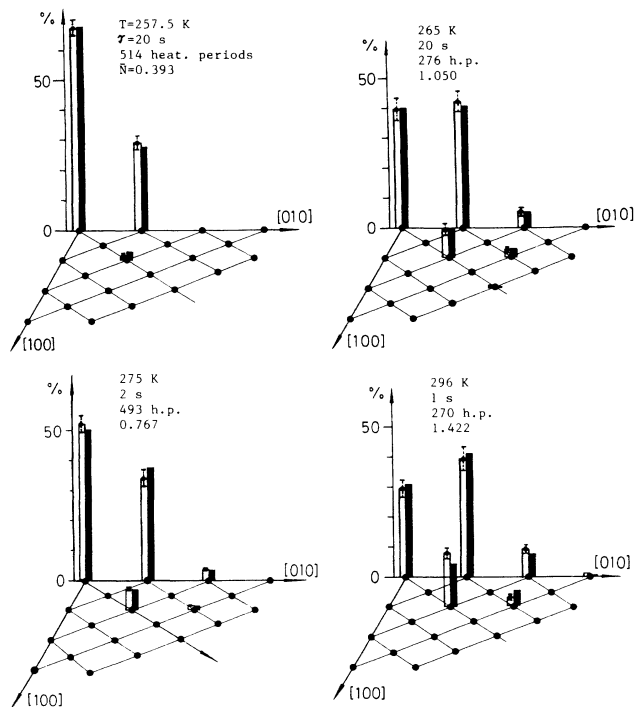

FIG. 5. Experimental 2D displacement distributions measured at four temperatures (blank bars) and theoretical distributions (solid bars) for the discrete nearest-neighbor random walk, calculated from the experimental mean-square displacements  $N$ . The lengths and the numbers of heating periods in these measurements are also listed.

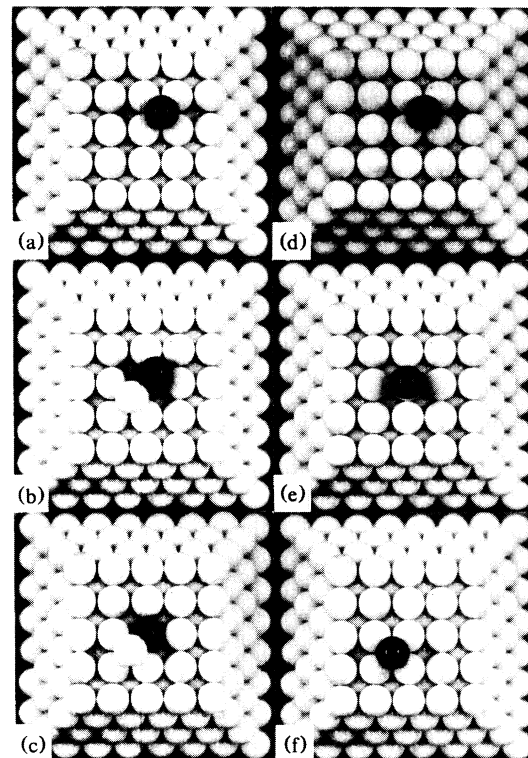

FIG. 6. (a)–(c) Exchange diffusion of an atom with a substrate atom, and (d)–(f) diffusion of an atom by an atomic jump over an atop site of the substrate.

the diffusion of Al on the Al(001) surface. Another possibility is that an Ir adatom jumps over the atop site of the substrate as illustrated in Figs. 6(d)–6(f). Based on the hard-sphere model, the jump height along the  $\langle 001 \rangle$  over the atop site will be 1.59 Å as compared to 0.86 Å if the jump is along  $\langle 110 \rangle$  over the twofold bridge site. Although one realizes that the factor determining the atomic jump direction is the direction of least height of the 2D potential-energy surface, it is highly unlikely that the least height is located at the atop site. We therefore believe that Ir adatom diffusion is achieved by an exchange diffusion similar to that proposed for Al on the Al(001) surface. This mode of diffusion will be favored if adsorption of an atom causes the surrounding four substrate atoms to bulge out slightly from their lattice sites because of the very strong binding between the adatom and the substrate. Since repeated atomic exchanges within one atomic jump by the diffusion atom is highly unlikely, this mode of diffusion is consistent with our measured 2D displacement distributions. It would be most interesting for theorists to find out whether the exchange diffusion is also favored for diffusion of Ir adatoms on the Ir(001) surface.

This work was supported by NSF.

<sup>1</sup>G. Ehrlich and K. Stolt, *Ann. Rev. Phys. Chem.* **31**, 603 (1980); G. L. Kellogg, T. T. Tsong, and P. L. Cowan, *Surf. Sci.* **70**, 485 (1978); T. T. Tsong, *Prog. Surf. Sci.* **10**, 165 (1980); *Rep. Prog. Phys.* **51**, 759 (1988).

<sup>2</sup>D. W. Bassett and P. R. Weber, *Surf. Sci.* **70**, 520 (1978); J. D. Wrigley and G. Ehrlich, *Phys. Rev. Lett.* **44**, 661 (1980).

<sup>3</sup>P. J. Feibelman, in *Proceedings of 1989 AVS Annual Meeting*, Boston (unpublished); in *Proceedings of the 1990 APS March Meeting*, Anaheim, California (unpublished).

<sup>4</sup>See, for example, E. D. Boyes, A. R. Waugh, P. J. Turner, P. F. Mills, and M. J. Southon, in *Proceedings of the Twenty-Fourth International Field Emission Symposium*, Oxford, 1977 (unpublished); T. Abe, K. Miyazaki, and K. I. Hirano, *Acta Metall.* **30**, 457 (1982).

<sup>5</sup>P. L. Cowan and T. T. Tsong, *Surf. Sci.* **67**, 158 (1977).

<sup>6</sup>T. T. Tsong and R. Casanova, *Phys. Rev. B* **22**, 4632 (1980).

<sup>7</sup>P. J. Feibelman, *Phys. Rev. Lett.* **63**, 2488 (1989).

<sup>8</sup>G. Ehrlich, *J. Chem. Phys.* **44**, 1050 (1966); E. W. Montroll, *J. Math. Phys.* **6**, 167 (1965). Use of a 1D equation for analyzing 2D displacement distributions for W and W<sub>2</sub> on the W(110) surface can be found in Ref. 6.

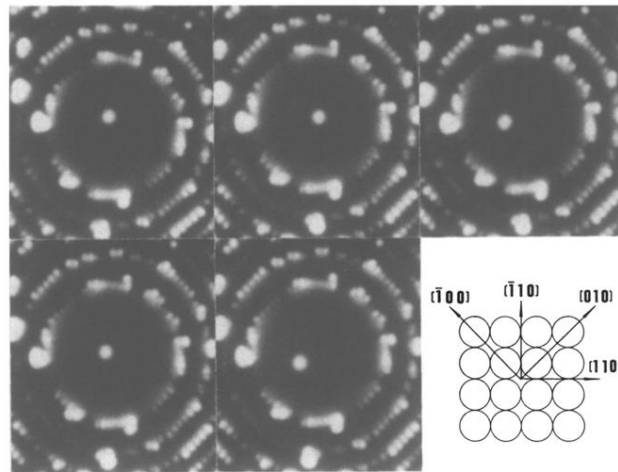

FIG. 1. A few field-ion images showing random-walk diffusion of one Ir atom on an Ir(001) surface.

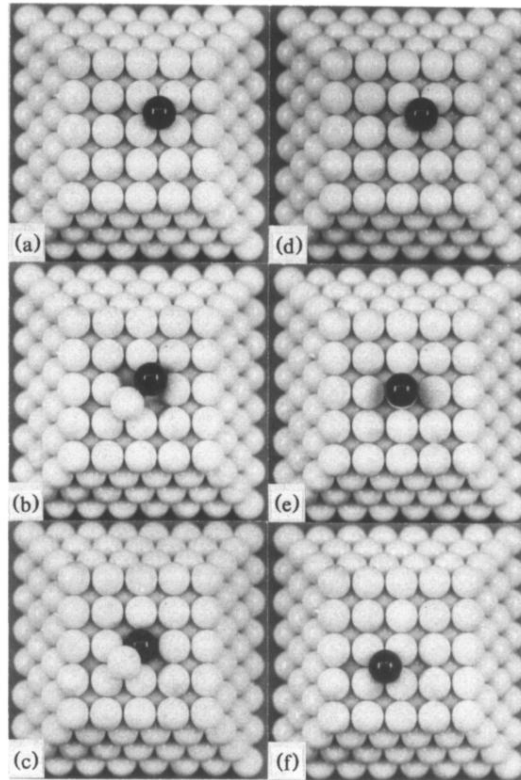

FIG. 6. (a)–(c) Exchange diffusion of an atom with a substrate atom, and (d)–(f) diffusion of an atom by an atomic jump over an atop site of the substrate.