

First Capture of Antiprotons in a Penning Trap: A Kiloelectronvolt Source

G. Gabrielse, X. Fei, K. Helmersen, S. L. Rolston, R. Tjoelker, and T. A. Trainor

Department of Physics, University of Washington, Seattle, Washington 98195

H. Kalinowsky and J. Haas

Institute für Physik, University of Mainz, West Germany

and

W. Kells

Fermi National Accelerator Laboratory, Batavia, Illinois 60510

(Received 8 September 1986)

Antiprotons from the Low Energy Antiproton Ring of CERN are slowed from 21 MeV to below 3 keV by being passed through 3 mm of material, mostly Be. While still in flight, the kiloelectronvolt antiprotons are captured in a Penning trap created by the sudden application of a 3-kV potential. Antiprotons are held for 100 s and more. Prospects are now excellent for much longer trapping times under better vacuum conditions. This demonstrates the feasibility of a greatly improved measurement of the inertial mass of the antiproton and opens the way to other intriguing experiments.

PACS numbers: 14.20.Dh, 29.25.Fb

Antiprotons are produced in high-energy particle accelerators at kinetic energies of several gigaelectronvolts. In recent years, the unique Low Energy Antiproton Ring (LEAR) at CERN has stochastically cooled and slowed antiprotons down to 5 MeV, making possible a large number of nuclear- and particle-physics experiments.^{1,2} A whole new range of intriguing possibilities is opened up if antiprotons of much lower energy are made available, especially if they can be caught and confined for substantial times in the small volume of an ion trap. For example, if a single antiproton can be confined in a Penning trap for a day or longer, a significantly improved comparison (by 4 orders of magnitude) can be made between the inertial masses of the antiproton and the proton.³ With even modest numbers of antiprotons, collision studies between trapped antiprotons and controlled levels of background gas can be carried out. For example, one can contemplate a precise measurement of the protonium $K\alpha$ energy without collisional broadening. If sufficient numbers of antiprotons can be accumulated, there is the possibility to synthesize antihydrogen, perhaps by confining antiprotons and positrons together in a radio-frequency trap⁴ or in a nested pair of Penning traps,^{5,6} or perhaps by sending a positronium beam into a cloud of trapped antiprotons.⁷ There is also the suggestion to measure the gravitational acceleration of antiprotons launched from a Penning trap.^{8,9} Perhaps a gravity measurement could instead be done with antihydrogen atoms to reduce the extreme sensitivity to stray electric fields.

Unfortunately, antiprotons with kinetic energies below 5 MeV are not readily available. Further deceleration stages to follow LEAR are certainly feasible, but they are rather complicated and expensive and have not yet

been built. An early proposal to trap antiprotons which relies on such deceleration¹⁰ has thus not been realized. A brief suggestion that it might be possible to trap one antiproton per hour in an electron-positron storage ring⁴ has also not been pursued. In this Letter, we report the first capture and storage of antiprotons in a Penning trap. A fraction of the 21.3-MeV antiprotons received from LEAR are slowed by more than 4 orders of magnitude in kinetic energy, via collisions in matter, to below 3 keV. Many are captured and stored for more than 100 s in a vacuum which can be greatly improved. These experiments were done in 24 h at LEAR after careful preparation with protons.⁵ They will continue in late 1987 when the improved LEAR facility resumes operation.

The normal mode of operation at LEAR is a slow and uniform spill of up to 3×10^9 antiprotons to experiments over approximately 1 h. In a new mode of operation set up for this experiment, stochastically cooled 21.3-MeV antiprotons in LEAR are instead bunched into four bunches. One is kicked down the beam line in a 150-ns burst and the remaining three are debunched. The cooling, bunching, and fast extraction are then repeated up to 10 times or the remaining antiprotons can be slowly extracted in the normal way. We trap antiprotons from even the weakest burst ($\approx 10^7$ antiprotons) which can be manipulated in and extracted from LEAR. The number of antiprotons in the burst is measured with a toroid transformer placed around the beamline near its end.

The antiproton burst leaves the LEAR vacuum through a 100- μm beryllium vacuum window and begins a several-centimeter flight through air. It goes through a thin proportional chamber (1.3 cm, primarily of Ar at 1 atm) to ascertain its spatial profile and through a 0.1-

mm plastic scintillator to generate a timing signal. The half-intensity beam diameter at the chamber is 0.3 cm, which is essentially the same as we measured with slowly extracted antiprotons. The intense burst then enters the vacuum enclosure for the trap through a second 100- μm Be window and travels along the axis of a 6-T superconducting solenoid. The strong magnetic field has a relatively minor effect and no special focusing elements are required.

The antiprotons lose energy via collisions with electrons inside a thick Be degrader window, located within the 6-T solenoid as shown in Fig. 1. Our earlier measurement¹¹ established that approximately 1 in 10^4 of the incident antiprotons emerges with a kinetic energy below 3 keV from a degrader with an optimum thickness equal to the range of the 21.3-MeV antiprotons. In fact, the dE/dx energy loss of protons and antiprotons is similar enough that proton range tables provide a reliable estimate of this thickness. Since only antiprotons with kinetic energies below 3 keV can be caught in the trap described below, this gives a maximum of 10^4 antiprotons available for trapping from a burst of 10^8 antiprotons received from LEAR.

The slowest antiprotons leaving the thick degrader are confined to field lines of the solenoid (dotted lines in Fig. 1) and are so guided through the series of three cylindrical trap electrodes. As the antiprotons enter the trap, the first electrode (the entrance end cap) and the center (ring) electrode are both grounded. The third electrode (exit end cap) is at -3 kV so that negative particles with energy less than 3 keV turn around on their magnetic field lines and head back towards the entrance of the trap. Approximately 300 ns later, before the antiprotons can escape through the entrance, the potential of the entrance end cap is suddenly lowered to -3 kV, catching them within the trap. The potential is switched

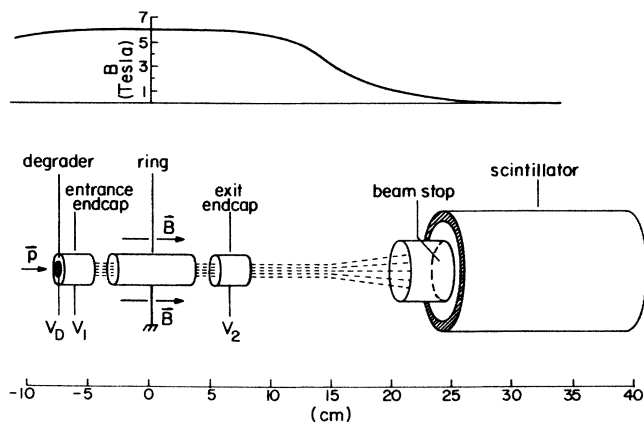

FIG. 1. Outline of the trap electrodes and the scintillator. The direction of the homogeneous magnetic field is indicated by the arrow, its magnitude along the center axis is plotted above and important field lines are indicated by dashed lines.

in 15 ns with a krytron circuit developed for this purpose and is applied to the trap electrodes via an unterminated coaxial transmission line.¹² By contrast, a potential of several volts was recently applied¹³ in 0.1 μs to capture Kr^+ .

After antiprotons are held in the trap for 1 ms to 10 min, the potential of the exit end cap is switched from -3 kV to 0 V in 15 ns,¹² releasing the antiprotons from the trap. They leave the trap along respective magnetic field lines and annihilate at a beam stop well beyond the trap, producing high-energy charged pions. These are detected in a 1-cm-thick cylindrical scintillator outside the vacuum system. The efficiency for the detection of an annihilation at the beam stop is measured to be 0.75, which is consistent with the pion multiplicity and the solid angle subtended. A multiscaler starts when the potential is switched and records the number of detected annihilations over the next 6 μs in time bins of 0.4 μs . A second multiscaler records the pion counts over a wider time range, with less resolution, to monitor backgrounds. This time-of-flight method is similar to but less refined than that used with very-low-energy electrons and protons.¹⁴

Figure 2 shows a time-of-flight spectrum for antiprotons kept in the trap for 100 s. The spectrum includes 31 distinctly counted annihilations which corresponds to 41 trapped particles when the detector efficiency is included. We carefully checked that these counts are not electronic artifacts. When the high voltage on the exit end cap is switched without antiprotons in the trap, a single count (occasionally two) is observed in the multichannel scalers. We take this to be time $t = 0$ and always remove a single count from the measured spectra. Otherwise, the background is completely negligible. When the potential of the entrance end cap is switched on just 50 ns before 3-keV antiprotons arrive in the trap, when the magnetic field is off, or when the -3 kV on one of the electrodes is adiabatically turned off and then back on during a 100-s trapping time to release trapped antipro-

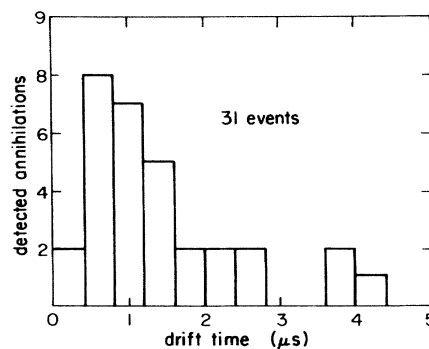

FIG. 2. Time-of-flight spectrum of detected pions from antiproton annihilation. The antiprotons were held 100 s in the trap and then released from the trap at time $t = 0$.

tons, no other counts are observed.

The potential on the exit end cap is lowered quickly compared with the transit time of particles in the trap in order to maximize the detection efficiency. Even a small number of trapped particles can be observed above possible background rates in the 6- μ s window. For trapping times shorter than 100 s, however, we actually release so many trapped antiprotons that our detection channel is severely saturated. For a 1-ms trapping time, we can conservatively establish that more than 300 antiprotons are trapped out of a burst of 10^8 , which corresponds to trapping 3×10^{-6} of the antiprotons incident at 21.3 MeV and 3% of the antiprotons slowed below 3 keV in the degrader. The release of 300 antiprotons uniformly over the 3- μ s width observed in Fig. 2 already corresponds to a count rate of 100 MHz. For the much higher numbers of antiprotons which are actually trapped, the resulting saturation makes it impossible to do more than set a lower limit. Now that it is established that this many particles can be trapped and that background rates are negligible for trapping times of 100 ms and longer, the antiprotons will be released slowly compared to the transit time of antiprotons in the trap in future experiments. This will reduce the instantaneous count rate and will also provide a total energy spectrum of the released antiprotons, without a time-of-flight measurement.

The observed capture of antiprotons immediately establishes that a possible background pressure surge (because of atoms knocked free of the degrader¹⁵ by the antiprotons directly or as a result of degrader heating, since energy lost by the antiprotons is deposited in the degrader at a rate of 2 kW during the 150-ns burst) is not enough to immediately annihilate the slow antiprotons. This is a crucial observation since details of an initial surge are difficult to estimate. All background gas in the burst, except for helium and hydrogen, is rapidly cryopumped by the cold surfaces because the trap electrodes and the vacuum enclosure are cooled to below 11 K. On the other hand, the present apparatus was not baked so that large numbers of atoms are adsorbed on the surface of the degrader, from where they could be dislodged by the burst of antiprotons.

We observe that five particles remain in the trap after 10 min. This is actually based upon only two trials, both of which involved a burst of antiprotons from LEAR of comparable intensity to that used for the 41 trapped particles of the 100-s spectra in Fig. 2. If a simple exponential decay describes the number of particles trapped between 100 s and 10 min, the decay time is 240 s. An extrapolation back to the loading time $t=0$, however, would then indicate that only 62 particles are initially trapped. We clearly observe many more for a trapping time of 1 ms, suggesting that antiprotons are lost more rapidly at earlier times.

Even without an initial pressure surge, a nonexponential decay is not at all surprising given that several pro-

cesses affect the rate of antiproton annihilation. Although calculated annihilation cross sections decrease very rapidly above 10 eV,¹⁶ even the highest-energy antiprotons in the trap spend some time at low velocities insofar as they oscillate back and forth along the magnetic field, stopping and turning around at each end. As an added complication, the equilibrium pressure within the present trap is not nearly as good as will be achieved in future experiments. This pressure depends upon the cryopumping mentioned above and is also affected by a small aperture, 0.9 m from the trap, which links the trap vacuum and a Dewar vacuum (at 10^{-6} Torr). We estimate that collisions with the background gas atoms could slow the antiprotons to lower energies, thereby hastening their annihilation. An initial pressure surge would increase this dE/dx cooling at earlier times, before released atoms are cryopumped. A key point here is that the rate of cooling and annihilation via collisions with background gas will decrease with decreasing pressure. The background pressure can be made lower by orders of magnitude compared with the present vacuum by cooling a completely sealed vacuum enclosure to 4.2 K. We thus expect a very significant increase in achievable trapping times. Finally, electron cooling of the trapped antiprotons (discussed below) should also be occurring for the longest trapping times already observed. From the limited amount of data accumulated so far, however, we can only conclude that it is now feasible to study these processes.

Because of its potential importance for the future measurements listed earlier, the possibility of cooling via collisions with a buffer gas of cold-trapped electrons deserves further mention. When the background pressure is greatly reduced, such electron cooling seems to be the most promising method of cooling trapped antiprotons from kiloelectronvolt to electronvolt energies. In fact, electrons are probably already confined in the present trap, under the assumption that each antiproton emerging from the degrader liberates several electrons and many of them are trapped. A 1-keV antiproton traveling through a cloud of 1-eV electrons with density of $10^8/\text{cm}^3$ loses energy exponentially with a time constant of 1 s or less, which is much shorter than the time antiprotons were held. Although such an estimate of electron cooling rates within a trap was only done recently,¹⁷ and the possibility of spatial separation of trapped electrons and antiprotons must be investigated,¹⁸ such cooling is quite well understood both experimentally and theoretically insofar as cold-electron beams have often been used to cool various particle beams traveling along the same axis with the same velocity.¹⁹

In conclusion, more than 300 antiprotons with kinetic energy below 3 keV are captured from a single 150-ns burst of 10^8 antiprotons at 21 MeV from LEAR. With 5-MeV antiprotons and higher trapping potentials, it should be possible to improve the number of particles trapped by a factor of 100. Based upon 100-s and 10-

min trapping times (already long enough to transfer the antiprotons into a higher quality trap or into an interaction region where low-energy antiprotons are desired), prospects are now excellent for holding antiprotons for a much longer time under improved vacuum conditions, perhaps as long as the 10-month confinement time realized with a single electron.²⁰ The confinement of antiprotons in a trap demonstrates the feasibility of a greatly improved measurement of the inertial mass of an antiproton and opens up a whole new range of experimental possibilities as well.

We are grateful to the LEAR staff for delivering the intense bursts of antiprotons in their first attempt. The muon group at TRIUMF graciously provided the thin plastic scintillator. This work was supported by the National Science Foundation, a Precision Measurements Grant from the National Bureau of Standards, the Air Force Office of Scientific Research, the Argonne Universities Association, and the Department of Energy through the Fermi National Accelerator Laboratory. Some preparatory experiments with protons were carried out at the tandem accelerator of the Nuclear Physics Laboratory of the University of Washington, which is also supported by the Department of Energy.

¹*Physics at LEAR with Low-Energy Cooled Antiprotons*, edited by U. Gastaldi and R. Klapisch (Plenum, New York, 1982), p. 771.

²*Physics Antiprotons at LEAR in the ACOL Era*, edited by U. Gastaldi, R. Klapisch, J. M. Richard, and J. Tran Thanh Van (Editions Frontières, Gif-Sur-Yvette, 1985).

³G. Gabrielse, H. Kalinowsky, and W. Kells, in Ref. 2; G. Gabrielse, H. Kalinowsky, W. Kells, and T. Trainor, CERN

Report No. CERN/PSCC/85-21PSCC/P83, 1985 (unpublished).

⁴H. Dehmelt, R. S. Van Dyck, Jr., P. B. Schwinberg, and G. Gabrielse, *Bull. Am. Phys. Soc.* **24**, 757 (1979).

⁵G. Gabrielse, K. Helmerson, R. Tjoelker, X. Fei, T. Trainor, W. Kells, and H. Kalinowsky, in *Proceedings of the First Workshop on Antimatter Physics at Low Energy*, edited by B. E. Bonner and L. S. Pinsky (to be published).

⁶G. Gabrielse, L. Haarsma, and W. Kells, to be published.

⁷B. I. Deutch, A. S. Jensen, A. Miranda, and G. C. Oades, in *Proceedings of the First Workshop on Antimatter Physics at Low Energy*, edited by B. E. Bonner and L. S. Pinsky (to be published).

⁸T. Goldman and M. M. Nieto, *Phys. Lett.* **112B**, 437 (1982).

⁹N. Beverini, L. Bracci, V. Lagomarsino, G. Manuzio, R. Parodi, and G. Torelli, CERN Report No. CERN/PSCC/83-14PSCC/P68, 1983 (unpublished); N. Beverini *et al.* CERN Report No. CERN/PSCC/86-2PSCC/P94, 1986 (unpublished).

¹⁰N. Beverini, L. Bracci, V. Lagomarsino, G. Manuzio, R. Parodi, and G. Torelli, in Ref. 1.

¹¹Gabrielse *et al.*, to be published.

¹²X. Fei, R. Davisson, and G. Gabrielse, unpublished.

¹³H. Schnatz *et al.*, *Nucl. Instrum. Methods* (to be published).

¹⁴G. Graff, H. Kalinowsky, and J. Traut, *Z. Phys.* **297**, 35 (1980).

¹⁵S. K. Erents and G. M. McCracken, *J. Appl. Phys.* **44**, 3139 (1973).

¹⁶J. S. Cohen, R. C. Martin, and W. R. Wadt, *Phys. Rev. A* **27**, 1821 (1983).

¹⁷W. Kells, G. Gabrielse, and K. Helmerson, Fermilab Report Conf. No. 84/68 E (unpublished).

¹⁸D. J. Larson, J. C. Berquist, J. J. Bollinger, W. M. Itano, and D. J. Wineland, *Phys. Rev. Lett.* **57**, 70 (1986).

¹⁹F. T. Cole and E. E. Mills, *Ann. Rev. Nucl. Sci.* **31**, 295 (1981).

²⁰G. Gabrielse, H. Dehmelt, and W. Kells, *Phys. Rev. Lett.* **54**, 537 (1985).