

Single and Double Ionization of Helium by Fast Antiproton and Proton Impact

L. H. Andersen, P. Hvelplund, H. Knudsen, and S. P. Møller
Institute of Physics, University of Aarhus, DK-8000 Aarhus C, Denmark

and

K. Elsener, K.-G. Rensfelt, and E. Uggerhøj
CERN, CH-1211 Geneva 23, Switzerland
 (Received 4 August 1986)

The first ion-atom-collision data obtained with antiprotons are presented. We measured the single- and double-ionization cross section for 0.5–5-MeV antiprotons and protons colliding with helium. For ion energies above ~ 2 MeV, the single-ionization cross section is the same for protons and antiprotons. However, surprisingly, the double-ionization cross section for antiprotons is approximately a factor of 2 larger than that for protons. The present data constitute a challenge for future theoretical models of charged-particle-atom collisions.

PACS numbers: 34.50.Fa

A powerful method for disclosing the various mechanisms that create atomic transitions in ion-atom collisions is to investigate the dependence of the relevant cross sections on the projectile charge. With the establishment of a low-energy antiproton beam at the Low-Energy Antiproton Ring (LEAR) facility at CERN, we are now able to compare such cross sections for heavy projectiles of opposite charge but having the same mass. We present in this Letter the first such experimental investigation.

Most theoretical studies of collisions between charged particles and many-electron atoms have until now been based on the so-called independent-particle model. Here atomic transitions are calculated as if the active electron were independent of the other target electrons, the presence of which is approximately accounted for by an effective potential. However, as pointed out by, e.g., Ford and Reading¹ and McGuire,² there are a number of cases where this approximation is clearly inadequate, and it is generally accepted that future developments of theory in this field must include effects stemming from both static and dynamic electron-electron correlation. Currently, such refinements are emerging,^{1,3} and it is therefore important to obtain experimental data for correlation-influenced processes that will make possible a judgment of the validity of these new theoretical approaches to the many-particle problem.

One such collision process, which is especially suitable, is the double ionization of helium by ~ 1 -MeV/amu singly charged pointlike particles. There are a number of reasons for this: First, the helium atom is the simplest target containing more than one electron. Second, due to the small nuclear charge, both static and dynamic electron-electron interactions give rise to large effects in the double-ionization cross section,⁴ and third, the primary projectile single-electron interaction is well understood and can be treated accurately by first-order perturbation theory.

The main parameter to be discussed in this Letter is

the ratio R between the double- and single-ionization cross section. This parameter is determined directly and with high accuracy in our experiment. It further contains the basic information on the processes causing double ionization.

The experimental technique is very similar to that used earlier by some of us⁵ to measure ionization of noble-gas atoms by positively charged, fast particles. The antiprotons were extracted as a 105.5-MeV/ c dc beam from the LEAR facility at CERN. They exit from the LEAR vacuum through a Be window and pass through a short distance of atmospheric air and a thin Mylar foil into our experimental setup (Fig. 1). Here they pass through an annular scintillator, which was used in the beam-steering procedure. Then they enter the target gas which consists of a few mTorr pure helium and is located between two plane condenser plates. An electric field of 800 V/cm between the plates extracts the created slow ions through a high-transparency net into a flight tube. Here the ions are focused by a voltage increase to -3500 V onto a ceramic Channeltron detector with a cone voltage of -3900 V. The condenser-plate flight-tube system is designed so as to give ions of the same specific charge, but created at various positions in the reaction region, the same flight time. The antiprotons exit from the gas cell through a thin Al window and are finally detected by a scintillator-photomultiplier-tube (PMT) system further downstream. Using the Channeltron pulse as a start signal and the (delayed) end-scintillator pulse as a stop signal, we obtain a time-of-flight spectrum with well-resolved peaks corresponding to each specific charge of the slow ions. To obtain data for lower projectile energy, Al foils of various thicknesses were placed in front of the Mylar foil. Measurements with protons were performed at the EN-tandem accelerator at Aarhus, with essentially the same setup.

Figure 2 shows the time-of-flight spectra obtained with ~ 4.5 -MeV/amu antiprotons and protons. In the antiproton spectrum, we observe a "prompt" peak

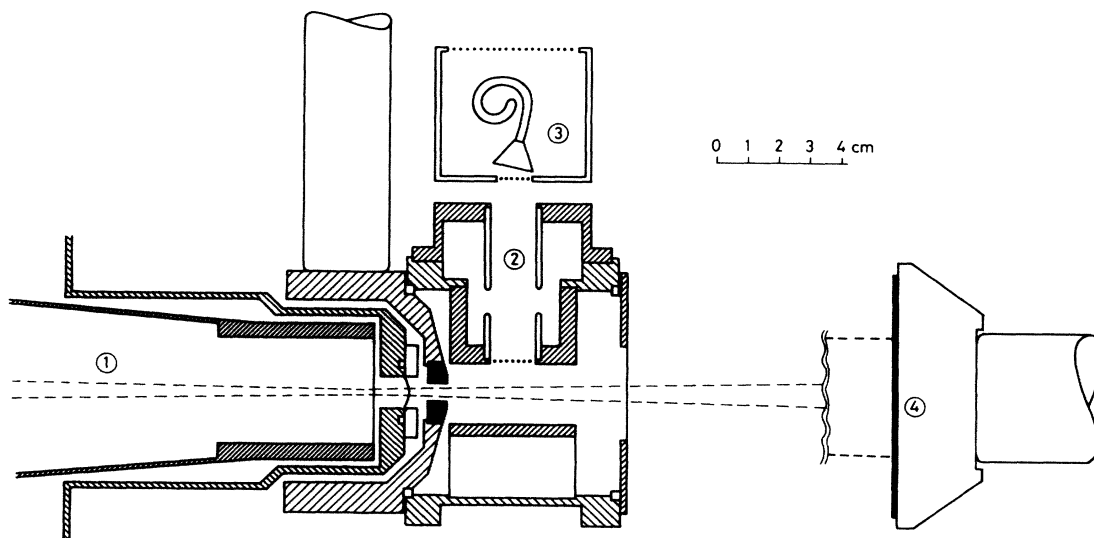

FIG. 1. Schematic drawing of the experimental setup. The dashed lines indicate the beam size (HWHM) for ~ 4.5 -MeV p^- . (1) LEAR vacuum. (2) Flight tube. (3) Channeltron detector. (4) End detector.

which is due to annihilation products from the stop detector that triggers the Channeltron. The first ions to arrive at the Channeltron after passage of a beam particle are H^+ stemming from the residual gas (H_2O) in our vacuum. This peak is also present with no helium-gas inlet. Then He^{++} ions arrive, and finally He^+ ions are detected. The "tail" on the He^+ peak is due to He^+ ions undergoing a resonant charge exchange with a helium atom during the acceleration. Its magnitude is proportional to the target pressure squared. Several experimental checks show that there is no contamination of the He^{++} peak from H_2^+ ions.

From the time-of-flight spectra, we obtain directly

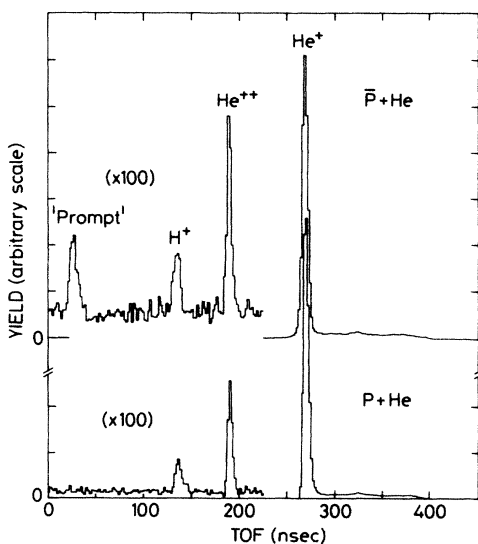

FIG. 2. Time-of-flight spectra obtained with ~ 4.5 -MeV p^- and p colliding with 3-mTorr He. The two spectra are normalized to the same He^+ yield.

the ratio R between the double- and single-ionization cross section for helium. It was found to be independent of target pressure at moderately low pressures. By extrapolation to zero target pressure of the yield of He^+ ions divided by the target pressure and by the accumulated number of projectiles, we found a preliminary single-ionization cross section. However, due to the multiple scattering of the beam particles in the Be window (and in the degrader foil), we had to have a rather large opening in the bottom of the time-of-flight tube. This made the determination of the effective target pressure somewhat uncertain. We have therefore applied a correction factor to all our measured preliminary cross sections. This factor was found as the ratio between the cross section recommended for protons by Rudd, Kim, Madison, and Gallagher⁶ and our preliminary proton value for our highest proton energy.

The collision energy associated with our measured values of R and our cross sections has been calculated as the original particle energy (as given by the accelerator calibration) minus the energy loss of the projectiles in the various windows and degraders. We used the proton stopping-power values of Andersen and Ziegler.⁷ In the case of antiprotons, these stopping powers were corrected by the Barkas term of Lindhard.⁸ This procedure introduces little uncertainty for the high-energy data. For the low-energy antiproton measurements the collision energy was obtained from the time of flight for the antiprotons between the collision region and the end detector. This time can be extracted from the position of the prompt peak in the time-of-flight spectra. For the intermediate-energy antiproton measurements, where both these methods are accurate, their results agree well.

Figure 3 shows our measured cross sections. For single ionization above ~ 2 MeV both the proton and the antiproton data agree with the solid curve which shows the recommended experimental proton values of Rudd, Kim, Madison, and Gallagher.⁶ That protons and antiprotons give the same single-ionization cross section (within the experimental uncertainty) at high energy agrees with expectations based on first-Born-approximation perturbation theory, where this cross section scales with the square of the projectile charge. Below 2 MeV, the antiproton data fall below the proton curve. We believe that this is (at least partly) due to polarization effects like those known from stopping-power calculations.⁸

For double ionization the proton data agree with the solid curve which shows the values of Rudd, Kim, Madison, and Gallagher for single ionization, combined with previous measurements of R for protons shown in Fig. 6 of Knudsen *et al.*⁵ The main result of the present work is, however, that 0.5–5-MeV antiprotons give approximately a factor of 2 larger double-ionization cross section than protons. At a first sight, this is quite surprising since, after all, double ionization is a consequence of one or more projectile-target-electron encounters, each of which can be accurately described in the first Born approximation.

At very high projectile velocity V , double ionization following only one projectile-target-electron encounter is expected to dominate.^{9,10} In one such mechanism it is assumed that one target electron is removed nearly instantaneously. Because of electron-electron correlation in the initial state, the wave function of the second electron is not orthogonal to the final continuum part of the He^+ ion, and, consequently,

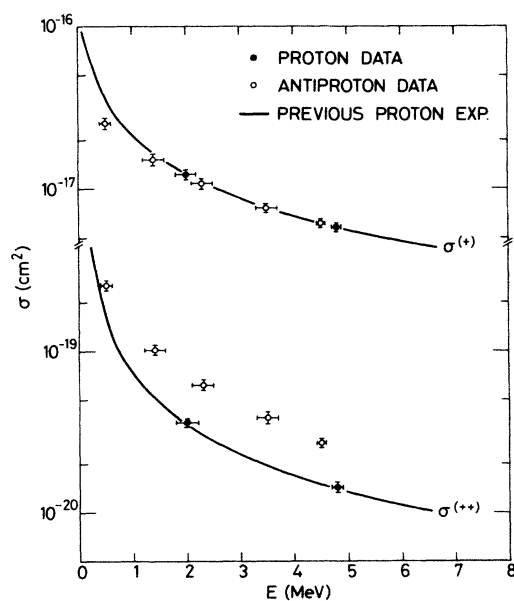

FIG. 3. The cross sections measured in this work.

there is some chance that the second electron will also be emitted. This is called the shakeoff (SO) process in the sudden approximation and leads to a constant value of R . This first-Born-approximation mechanism describes well double ionization of helium caused by high-energy photon impact¹¹ and double ionization following capture of one target electron to a high-energy proton.¹²

In our case, where we regard unrestricted double ionization by fast, charged particles, the electron, which had a direct encounter with the projectile, will generally leave the interaction region having a rather low velocity, and it will interact with the other target electron. This dynamic correlation diminishes significantly the SO value of R , as compared to the high-energy photon-impact value.¹⁰

Double ionization may also happen as a result of a process where the first electron, after its encounter with the projectile, collides with the second target electron, which is then also emitted.¹³ In the following we will denote this two-step (second-Born-approximation) process, which involves only one projectile-target-electron encounter TS-1. At high V , the recoil-energy spectrum of the first target electron is nearly independent of V ,¹⁰ and therefore TS-1 will probably give a constant R value in this limit.

For lower projectile velocities we expect that another two-step mechanism (TS-2), where the two target electrons are emitted because of two consecutive encounters with the projectile, will dominate. This process leads to a value of R proportional to $(V^2 \times \ln V)^{-1} q^2$, where q is the projectile charge.⁹

A simple addition of the cross sections for the mechanisms mentioned above leads to a value of R which is independent of the sign of the projectile charge. The difference between the double-ionization cross sections for protons and antiprotons found in this work shows such a procedure to be inadequate. The magnitude of the difference suggests that its explanation should be sought in an interference between the various mechanisms.

A few years ago, it was pointed out by Haugen, Andersen, Hvelplund, and Knudsen¹⁴ that for 2–5-MeV/amu electrons, R is approximately a factor of 2 larger than the value for equivelocity protons. McGuire¹⁰ suggested this difference to be due to an interference between the TS-2 and the SO process, as addition of the probability amplitudes for the two mechanisms might result in an interference term in R , which is proportional to the ion charge q .⁵

Subsequently, it was argued¹ that this interference is not possible, as in this region of dipole dominance, the double-ionization final state of the TS-2 process will be of a different (pp) symmetry from that of the SO process (sp). Also, it was speculated¹⁵ whether the difference might be due to the electron being so much

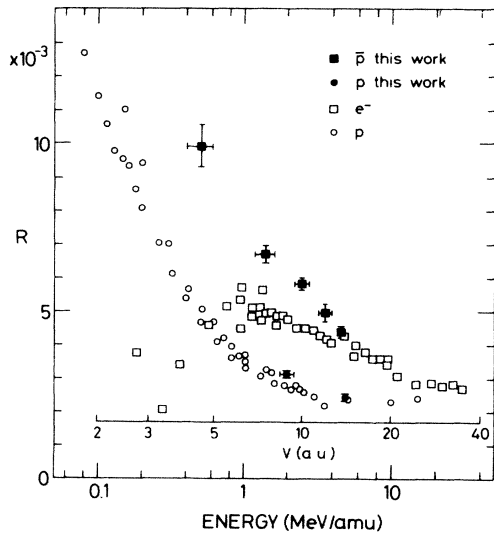

FIG. 4. The ratio R between double- and single-ionization cross sections for p^- , p , and e^- colliding with He. References to experimental data are given in Ref. 16.

lighter than the proton. However, no specific mechanism based on this fact has been found that can explain the large p^+ , e^- difference.

In Fig. 4 we compare the antiproton and proton data for the ratio R of this work with previously published proton and electron data (for references, see Shah and Gilbody¹⁶). As can be seen, the present proton data agree with the other proton measurements. The high-energy antiproton measurement is close to the value measured with equivalent electrons. (At lower energies, the R value for antiprotons is still much larger than the proton value, while the magnitude of R for electrons decreases, presumably because of the proximity of the threshold for double ionization by electrons at 79 eV corresponding to 145 keV/amu.) This comparison rules out the kinematical explanation of the e^- , p^+ difference.

It has been suggested¹⁷ that the large difference between the double-ionization cross sections for 0.5–5-MeV/amu projectiles of positive and negative unit charge colliding with helium might be due to an interference between the two second-Born-approximation mechanisms TS-1 and TS-2. It has been shown^{13,17} that their amplitudes are comparable in this velocity range. However, a firm conclusion as to the validity of this picture must be based on further de-

tailed calculations.

A more complete account of the present experiment, including a presentation of data for Ne and Ar targets, will be given in a forthcoming publication. The dramatic charge effects in multiple ionization found in this work should be further investigated. An important next step would be to measure the velocity dependence of the effect in an extended projectile-energy range. This could be one of the ways to disclose the amount of mixing of the various double-ionization mechanisms. Furthermore, the difference in the single-ionization cross section for p^+ and p^- observed at low projectile energies in this work calls for more experimental study.

We would like to thank P. Aggerholm for his enthusiastic help during the preparation and execution of the experiment, and J. Lindhard, A. H. Sørensen, and K. Taulbjerg for numerous helpful discussions.

¹A. L. Ford and J. F. Reading, Nucl. Instrum. Methods **B10&11**, 12 (1985).

²J. H. McGuire, in Proceedings of the U.S.–Mexico Joint Symposium on Electron Correlations, Cocoyoc, Mexico, 1986 (to be published).

³J. H. McGuire, Nucl. Instrum. Methods **B10&11**, 17 (1985).

⁴F. W. Byron and C. J. Joachain, Phys. Rev. Lett. **16**, 1139 (1966).

⁵H. Knudsen, L. H. Andersen, P. Hvelplund, G. Astner, H. Cederquist, H. Danared, L. Liljeby, and K.-G. Rensfelt, J. Phys. B **17**, 3545 (1984).

⁶M. E. Rudd, Y.-K. Kim, D. H. Madison, and J. W. Gallagher, Rev. Mod. Phys. **57**, 965 (1985).

⁷H. H. Andersen and J. F. Ziegler, *The Stopping and Ranges of Ions in Matter* (Pergamon, New York, 1977), Vol. 3.

⁸J. Lindhard, Nucl. Instrum. Methods **132**, 1 (1976).

⁹J. H. McGuire, Phys. Rev. Lett. **49**, 1153 (1982).

¹⁰J. H. McGuire, J. Phys. B **17**, L779 (1984).

¹¹See references in Ref. 6.

¹²E. Horsdal Pedersen and L. Larsen, J. Phys. B **12**, 4085 (1979).

¹³M. Gryzinski, Phys. Rev. **138**, A336 (1965).

¹⁴H. K. Haugen, L. H. Andersen, P. Hvelplund, and H. Knudsen, Phys. Rev. A **26**, 1962 (1982).

¹⁵J. F. Reading, Bull. Am. Phys. Soc. **29**, 821 (1984).

¹⁶M. B. Shah and H. B. Gilbody, J. Phys. B **18**, 899 (1985).

¹⁷J. Lindhard and A. H. Sørensen, private communication.