

## Repolarization of Negative Muons by Polarized $^{209}\text{Bi}$ Nuclei

R. Kadono, J. Imazato, T. Ishikawa, K. Nishiyama, K. Nagamine, and T. Yamazaki  
*Department of Physics and Meson Science Laboratory, Faculty of Science, University of Tokyo, Tokyo 113, Japan*

A. Bosshard, M. Döbeli, L. van Elmbt, M. Schaad, and P. Truöl  
*Physik-Institut der Universität Zürich, CH-8001 Zürich, Switzerland*

A. Bay and J. P. Perroud  
*Institut de Physique Nucléaire, Université de Lausanne, CH-1015 Lausanne, Switzerland*

J. Deutsch and B. Tasiaux  
*Institut de Physique Corpusculaire, Université Catholique de Louvain, B-1348 Louvaine-la-Neuve, Belgium*

and

E. Hagn  
*Physik Department, Technische Universität München, D-8046 Garching, Federal Republic of Germany*  
 (Received 28 April 1986)

A large  $\mu^-$  polarization was achieved in muonic Bi atoms with the help of the strong hyperfine field in a polarized nuclear target. Using  $^{209}\text{Bi}$  nuclei polarized to  $(59 \pm 9)\%$  in ferromagnetic BiMn, we observed a  $\mu^-e$  decay asymmetry of  $(13.1 \pm 3.9)\%$ , which gives  $\mu^-$  polarization per nuclear polarization equal to  $-1.07 \pm 0.35$ . This value is almost consistent with  $-0.792$  calculated for nuclei with spin  $I = \frac{9}{2}$  and a positive magnetic moment under the assumption that the hyperfine interaction becomes effective in the lowest muonic states.

PACS numbers: 36.10Dr, 23.40.Bw, 35.10.Fk

Since the development of the intense proton-accelerator facility known as the meson factory, positive and negative muons ( $\mu^+, \mu^-$ ) have been two of the most fruitful probes in various fields of physics.<sup>1</sup> However, because of the small spin polarization of the negative muon ( $\mu^-$ ) after the formation of a muonic atom (which is always the case for  $\mu^-$  in matter), experimental investigation by the  $\mu^-$  is still in the dawn in contrast to the established value of the  $\mu^+$  in fundamental physics, condensed matter physics, and so on. Actually, the residual polarization of  $\mu^-$  ( $= P_\mu$ ) in the  $1s$  ground state of a muonic atom is reduced to about  $\frac{1}{6}$  of its initial value through the atomic capture into a fine-structure doublet and the succeeding cascade process down to the  $1s$  state.<sup>2</sup> In the case of muonic atoms of nonzero-spin nuclei, there exists an additional loss of the polarization due to the hyperfine (hf) interaction, which reduces the final  $P_\mu$  to less than 5%.<sup>3</sup> It is absolutely clear that the introduction of a new method to increase  $P_\mu$  for the  $\mu^-$  will enable us to develop many interesting studies using the  $\mu^-$ .

In this paper we shall report an experimental study to realize the high spin polarization of negative muons. The principal idea of artificial polarization (i.e., "repolarization") for the  $\mu^-$  was proposed ten years ago<sup>4</sup> as a consequence of the study of polarized muonic atoms.<sup>5</sup> The process of repolarization consists of (a) the atomic capture of  $\mu^-$  by a polarized nucleus forming a muonic atom, (b) the hf coupling of the  $\mu^-$  spin

with the polarized nuclear spin in some muonic states, (c) the atomic transition by  $E1$  cascades down to the hf doublet of the  $1s$  state  $F^\pm (= I \pm \frac{1}{2})$ , where  $I$  refers to the nuclear spin), and (d) the final  $M1$  transition from the higher hf state to the lower one. On the assumption that the initial  $\mu^-$  polarization is equal to zero and that the hf coupling is active only at the  $1s$  state, the residual  $\mu^-$  polarization in pure  $F^\pm$  states after step (c) is calculated to be

$$P_\mu(F^+) = [(2I+3)I/(I+1)(2I+1)]P_N,$$

$$P_\mu(F^-) = -[(2I-1)/(2I+1)]P_N,$$

where  $P_N$  denotes the nuclear polarization. In the case of light nuclei (atomic number  $Z$  below 10), the last step (d) is slow compared with the  $\mu^-$  lifetime<sup>6</sup> and the population-averaged sum of  $P_\mu(F^+)$  and  $P_\mu(F^-)$  (i.e.,  $P_\mu$ ) remains small because of the opposite  $\mu^-$  polarizations in the respective states.<sup>7,8</sup> On the other hand, step (d) becomes much faster than the muon disappearance rate in heavier nuclei ( $\sim 10^{-9}$  sec) and  $P_\mu$  approaches

$$P_\mu(F^-) = -[4I(I+1)(2I-1)/(2I+1)^3]P_N$$

for positive  $\mu_I$ ,

$$P_\mu(F^+) = [4I^2(2I+3)/(2I+1)^3]P_N$$

for negative  $\mu_I$ , where  $\mu_I$  refers to the magnetic moment of the nucleus.<sup>4,5,7</sup> Note that the effect in-

creases with the nuclear spin  $I$ ; for instance, the above formula gives  $P_\mu = -0.792P_N$  for  $I = \frac{9}{2}$  with a positive nuclear moment.

It should be noted that the observation of such a repolarization effect itself is important enough to get a more correct understanding of the fundamental properties of muonic atoms. There are some indications in light nuclei that the hf coupling is "switched on" in muonic orbits higher than the  $1s$  one.<sup>9</sup> Recently, the influence of this effect on  $P_\mu$  was also calculated.<sup>10</sup> The calculation shows that the residual  $P_\mu$  depends on the assumed state where the hf splitting becomes larger than the decay width.

As already suggested in the original proposal,<sup>4</sup> a ferromagnetic compound BiMn ( $T_c = 633$  K) was chosen for the agent of the polarized  $^{209}\text{Bi}$  ( $I = \frac{9}{2}$ ) nuclear target. The strong internal magnetic field  $H_{\text{int}}$  of  $+940 \pm_{130}^{180}$  kG at Bi sites<sup>11,12</sup> and  $-224.5$  kG at Mn sites<sup>13</sup> is suitable to realize the large nuclear polarization by the thermal equilibrium method. The characteristic temperature  $T_0 = \mu_I H_{\text{int}} / k_B I$  for the nuclear polarization is  $T_0 = 31(5)$  mK for Bi and 11 mK for Mn, both of which are readily achievable with a  $^3\text{He}$ - $^4\text{He}$  dilution refrigerator. For a sample with a thin disk shape, an external field of 5–8 kG is required to get saturation magnetization along the disk plane. The target polarization was monitored by two carbon resistance thermometers which were calibrated in a separate experiment by  $\gamma$ -ray anisotropy measurements of  $^{207}\text{BiMn}$  dispersed in a small disk of the BiMn.<sup>12</sup>

The goal of this repolarization experiment was to determine the degree of  $\mu^-$  polarization acquired by unpolarized muons in muonic  $^{209}\text{Bi}$  atoms, by measurement of the decay-electron asymmetry for a known target polarization. The experiment was performed at the  $\mu E1$  channel of the Swiss Institute for Nuclear Research (SIN). The configuration of the  $e^-$  detector system is shown schematically in Fig. 1. The magnetic field was applied in the direction perpendicular to the  $\mu^-$  beam, eliminating any effect on the  $e^-$  asymmetry coming from the initial polarization of the  $\mu^-$  beam. Two NaI detectors were installed to measure the energy spectrum of the decay  $e^-$  with a total solid angle of about 1% for each side. The trigger condition for the "good"  $\mu^-e^-$  event was  $(\mu_1 \cdot \mu_2 \cdot \mu_3 \cdot \mu_4) \cdot [(TR_1 \cdot TR_2 \cdot \text{NaI-R}) \text{ or } (TL_1 \cdot TL_2 \cdot \text{NaI-L})]$ .

Negative muons of 115 MeV/c (partly 85 MeV/c) were stopped with a rate of  $2 \times 10^5/\text{sec}$  in the target, whereas the typical trigger rate was about 60 events/sec. In order to improve the signal-to-background ratio, four planes of multiwire proportional chambers were used to trace back the  $e^-$  trajectory. A Ge(Li) detector was placed near the target to monitor the number of the stopped muons and the atomic capture ratio of  $\mu^-$  in and around the target.

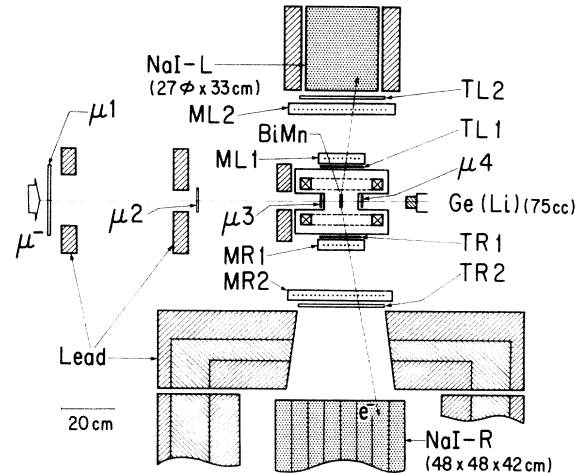

FIG. 1. Top view of the experimental setup. The letters  $\mu$ , T, and M refer to muon counters, electron counters, and multiwire proportional chambers, respectively. R and L denote right and left of the target as seen coming with the muon beam. NaI indicates the sodium iodide and Ge(Li) a high-resolution semiconductor detector.

To avoid systematic errors in our measurement, the degree of target polarization was varied by changing of the target temperature without any other changes in the experimental conditions. We repeated the measurements four times, each cycle consisting of pairs of experiments performed at both  $62 \pm 4$  mK and 1.0–4.2 K. The low-temperature experiments correspond to a polarization of  $(59 \pm 9)\%$  for Bi and  $(-21 \pm 1)\%$  for Mn. It took about 24 h to complete a pair of the measurements, during which the stability of the detector system was confirmed by the constancy of the trigger ratio between the R and the L sides (see Fig. 1). Additional split beam counters allowed us to monitor any left-right shift of the beam; none was observed. One of the four cycles was done with the magnetic field direction reversed.

The observables which were used for the final analysis are as follows: (a) the time spectra of electron decay events with respect to the  $\mu^-$  stop (up to 2  $\mu\text{sec}$ ), (b) the time spectra of the decay event relative to the  $\mu_1$  counter alone (up to 200 nsec), (c) the time spectra of the muon pileup signal during 2  $\mu\text{sec}$ , (d) the electron energy spectra of the NaI detectors, and (e) the hit patterns of the multiwire proportional chambers. The data acquisition was done with a PDP-11 computer and the information was recorded on magnetic tapes on an event-by-event mode.

In the off-line analyses, the efforts were directed toward the improvement of the signal-to-background ratio in the time spectra (a). All the events which did not hit the multiwire proportional chambers properly

were removed. The background in the "prompt" region of the spectra (a), probably coming from the contaminant  $e^-$  in the beam, was reduced by use of the information from (b). The effect of accidental secondary muons distorting the time spectra was eliminated by the rejection of events recorded in the spectra (c).

Because of the substantial energy loss in the target (an average of 15 g/cm<sup>2</sup> in the direction of the electrons) as well as the distortion of the decay spectrum from the bound muons,<sup>14-16</sup> the detected electrons have an energy spectrum concentrated in the lower-energy region. The decay events which have energy higher than 35 MeV have to originate from low- $Z$  contaminants (Al walls, carbon in the detectors) and were removed to improve the signal-to-background ratio in the spectra (a). By use of a maximum-likelihood method,<sup>17</sup> the spectra of (a) after these cuts were fitted with the function

$$N(t) = \sum_i N^i \exp(-t/\tau_i) + B,$$

where  $N^i$  refers to the counting rate of electrons at  $t=0$  for the  $i$ th component which has the lifetime  $\tau_i$ , and  $B$  refers to the constant background. The assumed components are Bi ( $\tau=73$  nsec), Mn ( $\tau=225$  nsec), Al ( $\tau=865$  nsec), and C ( $\tau=2038$  nsec), where the lifetimes were fixed and the  $N^i$ 's were determined through the fitting. A typical example of the spectrum is shown with a result of fitting in Fig. 2.

The time spectra of both  $R$  and  $L$  sides were analyzed independently and yield for each cycle of experiments the amplitudes  $N_R^i$  (62 mK),  $N_L^i$  (62 mK),  $N_R^i$  (4.2 K), and  $N_L^i$  (4.2 K). We shall discuss the analysis of the Bi components which have the most

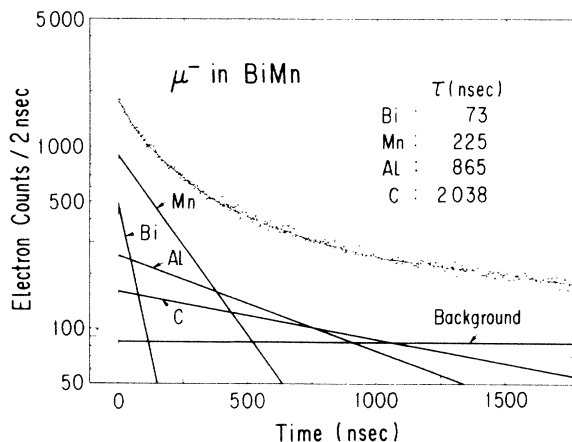

FIG. 2. A typical  $\mu$ - $e$  decay-time spectrum obtained after the various background cuts discussed in the text. The time resolution was 6–10 nsec. The muons are assumed to be captured by Bi, Mn, Al, and C, where the last two components are ascribed to muons stopped in the cryostat walls and in the scintillators.

TABLE I. The numerical results of the analysis for the Bi component. The sign behind the cycle number refers to the polarity of the polarizing magnetic field. For abbreviations, see text. The quoted error of  $C_{R,L}$  comes from statistics of the Monte Carlo calculation.

Cycle	$D$	$C_R$	$C_L$	$A_{\text{exp}}$
1(+)	1.147(131)	-1.011(19)	+0.419(11)	-0.098(84)
2(+)	1.191(85)	-0.644(16)	+0.430(13)	-0.165(70)
3(-)	0.871(78)	+0.681(17)	-0.497(12)	-0.116(74)
4(+)	1.175(107)	-0.692(15)	+0.443(13)	-0.144(83)
Average				-0.131(39)

precisely determined amplitudes.

If the polarization acquired by the muons is  $P_\mu$ , the emitted electrons are distributed as a function of their energy  $E$  and emission angle  $\theta$  relative to  $P_\mu$  as  $\alpha(E) + \beta(E)P_\mu \cos\theta$ . For the functions  $\alpha(E)$  and  $\beta(E)$  we assumed their theoretical forms extracted from Refs. 14–16; let us note that we obtain for the total asymmetry, integrated between  $E=0$  and  $E=E_{\text{max}}$ ,

$$A_0 = \int_0^{E_{\text{max}}} \beta(E) dE \left[ \int_0^{E_{\text{max}}} \alpha(E) dE \right]^{-1} = -0.21.$$

We compute now with Monte Carlo methods the acceptance of our detectors for both the isotropic and the nonisotropic distribution functions  $\alpha(E)$  and  $\beta(E)$ , taking into account also the energy cuts used in each cycle to construct the time distribution (a). Then, we can express  $A_{\text{exp}} = P_\mu A_0$  as a function of the experimentally measured amplitudes as

$$A_{\text{exp}} = (1 - D)/(DC_L - C_R),$$

where  $D$  is the double ratio  $[N_R(62 \text{ mK})/N_R(4.2 \text{ K})][N_L(62 \text{ mK})/N_L(4.2 \text{ K})]^{-1}$  and  $C_{R,L}$  is the correction factor from the Monte Carlo calculation.

In Table I the summary of the analysis is shown for Bi results. A preliminary result was reported elsewhere.<sup>18</sup> From  $A_{\text{exp}} = -0.21P_\mu = -0.131 \pm 0.039$  we obtain the repolarization coefficient  $P_\mu/P_{\text{Bi}} = -1.07 \pm 0.35$  which proves the feasibility of the method suggested in Refs. 4 and 5.

TABLE II. The repolarization efficiency of muons in muonic  $^{209}\text{Bi}$  atoms as a function of muonic states from where hyperfine coupling becomes active. The initial polarization of the muon is assumed to be zero.

$hf$ switched on	$P_\mu/P_{\text{Bi}}$
At 1s state	-0.792
At 2p state	-0.750
At 3d state	-0.688
Expt.	$-1.07 \pm 0.35$

Our result is compared in Table II with the theoretical values obtained with the assumption of the onset of the hyperfine interaction in various muonic-mesic levels. Because of the moderate precision we cannot distinguish between these scenarios; it would be also premature to do so before the theoretical assumption  $A_0 = -0.21$  is experimentally assessed (such an experiment is under way by our collaboration at SIN).

In summary, the present experiment has demonstrated for the first time that negative muon spin can be repolarized by the aid of nuclear polarization. This method will be powerful in studying  $\mu^-$ -spin-dependent phenomena.

We thank Dr. S. Arai for the preparation of the BiMn samples, Dr. R. S. Hayano for his help compressing data, and Dr. Y. Kuno for helpful discussion. Also we wish to thank Prof. J. P. Blaser for his hospitality at SIN, and the staff of SIN for their help with our experiment. The experiment was partly supported by a Grant-in-Aid of the Japanese Ministry of Education, Culture and Science.

---

<sup>1</sup>See, for example, *Muon Physics*, edited by V. W. Hughes and C. S. Wu (Academic, New York, 1977), Vols. 1-3.

- <sup>2</sup>R. A. Mann and M. E. Rose, *Phys. Rev.* **121**, 293 (1961).  
<sup>3</sup>H. Überall, *Phys. Rev.* **114**, 1640 (1959).  
<sup>4</sup>K. Nagamine and T. Yamazaki, unpublished.  
<sup>5</sup>K. Nagamine and T. Yamazaki, *Nucl. Phys.* **A219**, 104 (1974).  
<sup>6</sup>R. Wilson, *Phys. Rev.* **129**, 2766 (1961).  
<sup>7</sup>T. Yamazaki, *Nucl. Phys.* **A335**, 537 (1980).  
<sup>8</sup>L. Hambro and N. C. Mukhopadhyay, *Phys. Lett.* **68B**, 143 (1977).  
<sup>9</sup>D. Favart, F. Brouillard, L. Grenacs, P. Igo-Kemenes, P. Lipnik, and P. C. Macq, *Phys. Rev. Lett.* **25**, 1348 (1970).  
<sup>10</sup>Y. Kuno, K. Nagamine, and T. Yamazaki, *J. Phys. Soc. Jpn. Suppl.* **55**, 1040 (1986).  
<sup>11</sup>K. Nagamine, N. Nishida, and H. Ishimoto, *Nucl. Instrum. Methods* **105**, 265 (1972).  
<sup>12</sup>H. Koyama, K. Nagamine, N. Nishida, K. Tanaka, and T. Yamazaki, *Hyperfine Interact.* **5**, 27 (1977).  
<sup>13</sup>T. Hihara and Y. Koi, *J. Phys. Soc. Jpn.* **29**, 343 (1970).  
<sup>14</sup>V. Gilinsky and J. Mathews, *Phys. Rev.* **120**, 1450 (1960).  
<sup>15</sup>R. H. Huff, *Ann. Phys.* **16**, 288 (1961).  
<sup>16</sup>P. Hänggi, R. D. Viollier, U. Raff, and K. Alder, *Phys. Lett.* **51B**, 119 (1974).  
<sup>17</sup>See, for example, *Statistical Methods in Experimental Physics*, edited by W. T. Eadie *et al.* (North-Holland, Amsterdam, 1971).  
<sup>18</sup>R. Kadono *et al.*, *J. Phys. Soc. Jpn. Suppl.* **55**, 1038 (1986).

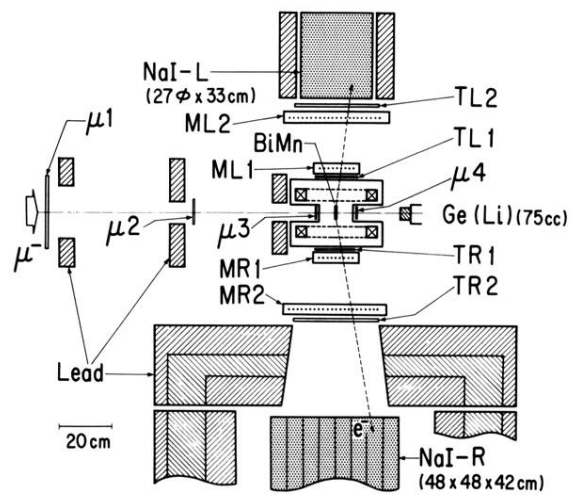

FIG. 1. Top view of the experimental setup. The letters  $\mu$ , T, and M refer to muon counters, electron counters, and multiwire proportional chambers, respectively. R and L denote right and left of the target as seen coming with the muon beam. NaI indicates the sodium iodide and Ge(Li) a high-resolution semiconductor detector.