

In this Letter, we have investigated the way in which electron motion in the field of an obliquely propagating Langmuir wave feeds back on the wave to affect its evolution. In the trapping regime, we found that the amplitude oscillations disappear as the angle of propagation increases. When a transition is made between the trapping and stochastic regimes, we found a significant decrease in the asymptotic ( $t \rightarrow \infty$ ) wave amplitude. Simulations verify this decrease and indicate that it is observable at any time greater than five bounce periods. The methods we used can be applied to a variety of other problems in which there is a transition from regular to stochastic behavior and the field evolution is of interest.

This work has been supported by U. S. Department of Energy Contracts No. DE-AM03-76-SF00010 PA 26, Tasks I and III, by National Science Foundation Contracts No. PHY-77-12873 and No. PHY-80-14189, and by the Fannie and

John Hertz Foundation.

<sup>1</sup>See, e.g., R. C. Davidson, *Methods in Nonlinear Plasma Theory* (Academic, New York, 1972), Chaps. 4 and 5.

<sup>2</sup>G. R. Smith and A. N. Kaufman, *Phys. Fluids* **21**, 2230 (1978).

<sup>3</sup>See, e.g., "Long-Time Prediction in Dynamics," edited by Wendell Horton, Linda Reichl, and Victor Szebehely (Wiley, New York, to be published).

<sup>4</sup>T. O'Neil, *Phys. Fluids* **8**, 2225 (1965).

<sup>5</sup>G. J. Morales and T. M. O'Neil, *Phys. Rev. Lett.* **28**, 417 (1972).

<sup>6</sup>T. H. Malmberg and C. B. Wharton, *Phys. Rev. Lett.* **19**, 775 (1967).

<sup>7</sup>See, e.g., T. H. Stix, *The Theory of Plasma Waves* (McGraw-Hill, New York, 1962), Chap. 8.

<sup>8</sup> $\sigma_0(x) - 1$  is plotted in Fig. 1 of T. T. Tsai, *J. Plasma Phys.* **11**, 213 (1974).

<sup>9</sup>See Tsai, *Rev.* **8**, and references cited therein.

## Smectic-A Order at the Surface of a Nematic Liquid Crystal: Synchrotron X-Ray Diffraction

J. Als-Nielsen and F. Christensen

*Risø National Laboratory, DK-4000 Roskilde, Denmark*

and

P. S. Pershan<sup>(a)</sup>

*Gordon McKay Laboratory, Division of Applied Sciences, Harvard University, Cambridge, Massachusetts 02138*

(Received 25 January 1982)

A novel geometry in which it is possible to do x-ray diffraction from a horizontal surface of fluids is applied to liquid crystals. A large-diameter drop of octyloxycyanobiphenyl (8OCB) on a glass plate treated for homeotropic alignment yields perfect alignment of the smectic-A layers at the top surface over an area of several square millimeters. The surface in the bulk nematic as well as in the isotropic phase was found to consist of smectic-A layers with a penetration depth equal to the longitudinal smectic-A correlation length  $\xi_{\parallel} \sim (T - T_{NA})^{-\nu_{\parallel}}$  determined previously.

PACS numbers: 61.30.Eb, 61.10.Fr, 61.30.Jf, 64.70.Ew

In spite of the large number of recent experimental<sup>1</sup> and theoretical studies<sup>2</sup> the nematic to smectic-A (N-A) phase transition is not well understood. The smectic-A phase has the interesting property that positional correlations of the layers do not have true long-range order but rather exhibit algebraic decay with a temperature-dependent exponent  $\eta$ .<sup>3</sup> Recent x-ray-diffraction studies have confirmed this result<sup>4</sup>; however, difficulties in controlling the mosaic spread of the smectic layers precluded measurements that are required for quantitative evalu-

ation of current proposals regarding the behavior of  $\eta$  as  $T \rightarrow T_{AN}$ .<sup>2</sup>

Some years ago one of us (P.S.P.) showed that if the effects of surface tension can be neglected the combination of a free surface and a parallel planar rigid surface with homeotropic alignment would naturally expel mobile defects.<sup>5</sup> This geometry thus suggested the possibility of a practical solution to the mosaicity problem. We report here the first x-ray-diffraction study of the horizontal free surface of a nematic liquid crystal.<sup>6</sup> In addition to sharp peaks, with unde-

tectably small mosaic spread for  $T < T_{AN}$ , we have observed the existence of smectic layers at the free surface for temperatures above  $T_{AN}$ .<sup>7</sup> The present manuscript is primarily concerned with the appearance of smectic ordering for  $T > T_{AN}$ .

The experiment was carried out at the synchrotron radiation laboratory HASYLAB at Deutsches Elektronen Synchrotron DESY in Hamburg. Figure 1 displays the experimental geometry necessitated by the requirement that the fluid sample be kept horizontal. A monochromatic beam of wave vector  $k$  is extracted from the polychromatic synchrotron spectrum by Bragg reflection from Si(111) planes of a triple-bounce channel-cut crystal  $M$ . The Bragg angle is  $\theta_{111}$  and  $\tau_{111} \equiv 2k \sin \theta_{111}$ . The monochromatic beam is bent downwards through an angle  $\theta_s$  by tilting the monochromator by an angle  $\varphi = (k/\tau_{111})\theta_s$ . Horizontal smectic layers with layer spacing  $d$  will give Bragg reflection of this beam when  $Q_0 \equiv (2\pi/d) = 2k \sin \theta_s = 2\tau_{111}\varphi$ . Note that in this particular geometry the Bragg condition is independent of wavelength in the small-angle approximation. An analyzer system symmetric with the monochromator obtains a horizontal beam that is detected in the position-sensitive detector (PSD). For a given setting successive channels of the PSD probe a line of reciprocal space making an angle  $\varphi/\cos \theta_{111}$  with the longitudinal, vertical direction. By scanning the monochromator tilt an entire plane in wave-vector transfer space is probed. The transverse wave-vector transfer component perpendicular to this plane is probed by rotating the analyzer crystal around a vertical axis.

We now discuss the scattering as obtained from the liquid crystal octyloxycyanobiphenyl (8OCB)

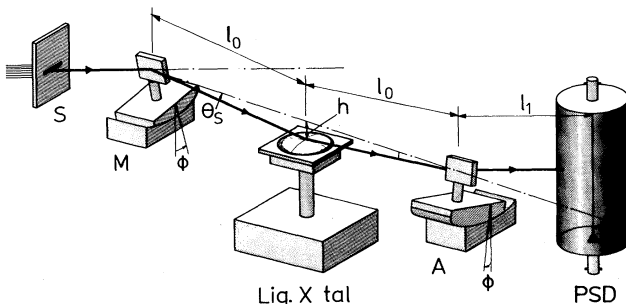

FIG. 1. Schematic illustration of the geometry for x-ray diffraction from a horizontal fluid surface. The slit  $S$  is  $0.1 \times 0.8 \text{ mm}^2$ ,  $l_0 = 575 \text{ mm}$ ,  $l_1 = 620 \text{ mm}$ , the wave vector  $k = 4.0786 \text{ \AA}^{-1}$ , and the Bragg vector for Si(111)  $\tau_{111} = 2.0039 \text{ \AA}^{-1}$ . Source-to-slit distance is 20 m.

held  $0.020^\circ\text{C}$  above the nematic to smectic-A transition temperature for bulk 8OCB,  $T_{AN} = 67.350^\circ\text{C}$ . Results for six different monochromator tilts are shown in Fig. 2(a). For each monochromator tilt setting, the intensity versus analyzer rotation was measured to be a sharp peak, less than  $0.001^\circ$  broader than the combined Darwin widths of the monochromator and analyzer ( $\sim 0.0023^\circ$ ). This implies a very sharply peaked cross section in the transverse wave-vector transfer  $\vec{Q}_\perp$ . The narrow width of each PSD spectrum in Fig. 2(a) is indeed consistent with this statement. If we take the cross section as a delta function in  $\vec{Q}_\perp$  [the intrinsic width,  $\Delta Q_\perp \approx (30\,000 \text{ \AA})^{-1}$ ], the peak intensity  $I_0(\varphi)$  of each PSD spectrum represents the dependence of the cross section on the longitudinal wave-vector transfer  $\alpha_z$ , folded of course with the longitudinal resolution function. Such data are shown in Fig. 2(c). The width  $w$  of the peak,  $0.0116^\circ$ , is at this temperature only slightly larger than the resolution of  $0.0090^\circ$ . Finally, the data in Fig. 2(b) of the peak channel versus tilt shows that the scattered beam peaks in the direction of specular reflection (line s) rather than that ex-

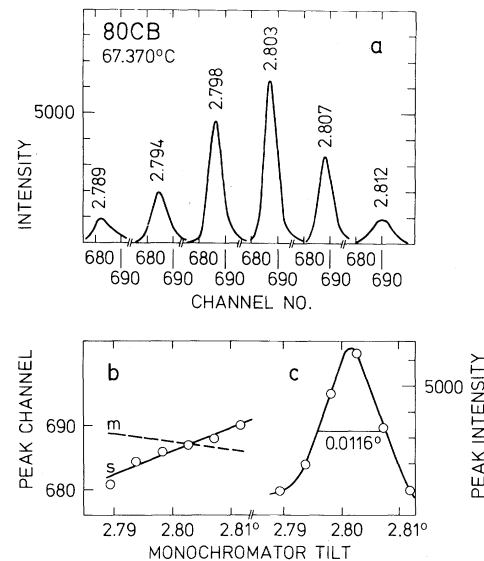

FIG. 2. (a) PSD spectra for different monochromator tilt angles. (b) Comparison between observed peak channel vs tilt and expected value if wave-vector transfer is normal to surface, that is, specular reflection (full line), and along the surface as in a mosaic crystal (dashed line). (c) Peak intensity vs tilt. Correction for resolution width ( $0.0090^\circ$ ) yields a longitudinal correlation range of  $\xi_{\parallel} \sim 6000 \text{ \AA}$  at a reduced temperature of  $5.9 \times 10^{-5}$ .

pected from a mosaic crystal (line m), again indicating an extremely sharply peaked cross section in  $\vec{Q}_\perp$ . With increasing temperature, the following features were observed: (i)  $I_0(\varphi)$  decreases and the width  $w$  increases but a peak remains even into the isotropic phase. Data are shown in Figs. 3(a) and 3(b). (ii) The width of each PSD spectrum remains as narrow as those in Fig. 2(a) and the widths of analyzer rotation scans remain Darwin limited. The free surface of 80CB acts as a temperature-dependent optically flat mirror for incident angles around  $1.4^\circ$ .

In obtaining these data the height  $h$  was adjusted to  $h = l_0(\tau_{111}/k)\varphi$  at each monochromator tilt setting  $\varphi$  and also the analyzer rotation was optimized at each setting. We shall now discuss and analyze these observations.

Item (ii) implies that the delta-function character in  $\vec{Q}_\perp$  is maintained at all temperatures whereas (i) implies a peak in the longitudinal direction  $q_z \equiv (\vec{Q} - \vec{Q}_0) \cdot \hat{z}$  which we take to be of Lorentzian form with a temperature-dependent width  $\xi_z^{-1}$ :

$$\alpha(\vec{Q}) = \alpha\sigma_0(\delta t)[1 + (\xi_z q_z)^2]^{-1}\delta(\vec{Q}_\perp), \quad (1)$$

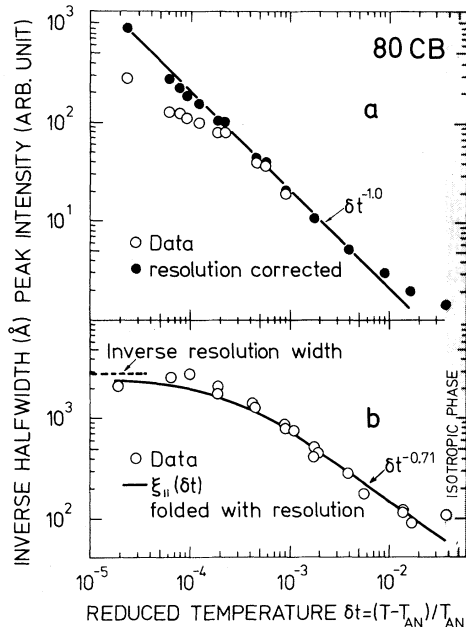

FIG. 3. (a) Temperature dependence of the peak intensity. The open circles are the raw data and the solid circles are the result of correction as described in the text. (b) Temperature dependence of the  $(\Delta Q_z)^{-1}$  for  $T > T_{AN}$ . The solid line is calculated by convolution of the resolution function with a Lorentzian with reciprocal of half width at half maximum of  $\xi_\parallel(T)$  as measured in the bulk nematic, Ref. 1.

$\alpha$  being a constant and  $\delta t$  the reduced temperature  $(T - T_{AN})/T_{AN}$ . The Lorentzian line shape and the width parameter  $\xi_z$  may be derived from the phenomenological free energy,

$$F = A(\delta t)|\psi|^2 + \gamma[(\partial/\partial z - iQ_0)\psi]^2 + \dots, \quad (2)$$

of the smectic order parameter  $\psi$ .<sup>8</sup> In the Landau or mean-field approximation  $A(\delta t)$  is taken to vary linearly with  $\delta t$ , yielding a spontaneous smectic phase below  $T_{AN}$  and critical fluctuations above  $T_{AN}$  with a longitudinal correlation range  $\xi_\parallel = (\gamma/A)^{1/2} \propto \delta t^{-1/2}$ . More generally  $\xi_\parallel = \xi_0(\delta t)^{-\nu_\parallel}$  and for bulk 80CB previous x-ray scattering studies have determined  $\xi_0 = 3.3 \text{ \AA}$  and  $\nu_\parallel = 0.71$ .<sup>1</sup> Under the assumption that the free surface is equivalent to a *boundary condition* of  $\psi = \psi_0$  at  $z = 0$ , the  $z$  dependence of  $\psi$  is found by minimizing  $F$ :

$$\psi = \psi_0 \exp[-z(iQ_0 + \xi_z^{-1})], \quad \xi_z = (\gamma/A)^{1/2}, \quad (3)$$

i.e., the penetration depth is simply identical to the correlation range of the bulk nematic phase.<sup>9</sup> The scattering cross section, Eq. (1), is obtained from the Fourier transform of Eq. (3), and we infer  $\sigma_0(\delta t) \propto \xi_\parallel^2 \propto (\delta t)^{-1.42}$ . The cross section must be folded with the instrumental resolution before comparison with experimental data. In Fig. 3(b) the full line shows the inverse width of a Lorentzian peak of width  $\xi_\parallel^{-1}$  folded with a triangular resolution function corresponding to a tilt width of  $0.0090^\circ$ ; c.f. Fig. 2(c). If we note that the comparison between this theoretical expectation and the observed widths does not involve any adjustable parameters the agreement must be said to be strikingly good. It was therefore somewhat surprising to find that the unfolded peak intensities, Fig. 3(a), do not vary as  $(\delta t)^{-2\nu_\parallel} = (\delta t)^{-1.42}$  but rather as  $(\delta t)^{-1.0}$ . One possibility, pointed out by B. Halperin, is that the boundary condition might be so strong, i.e.,  $\psi_0$  so large, that the linear theory represented by Eq. (2) is not applicable. In that case  $\psi$  would be expected to decrease from its surface value to a value within the linear range of the theory, in a distance much less than  $\xi_\parallel$ . This would have the effect of adding a broadened background to the line shape. We have not yet carried out detailed measurements of the tails of the peak.

In summary, we have demonstrated the feasibility of using synchrotron radiation, in a novel geometry, to study x-ray diffraction from the horizontal surface of fluid samples. Structure observed in specular reflection can be correlated with the propagation into the bulk of positional molecular order imposed by the surface.<sup>10</sup> In

the nematic phase of 8OCB the propagation length coincides precisely with the correlation length previously measured in bulk samples. We have also demonstrated that smectic-*A* samples with vanishingly small mosaic spreads can be obtained with the free-surface technique. Subjects for future research include (a) detailed line-shape studies of both melting from the smectic-*A* to the nematic phase and the temperature-dependent intensity in the nematic phase; (b) quantitative comparison between the intensities due to smectic layering at the free surface and specular reflection due to the small but finite value of the x-ray index of refraction mismatch between the liquid crystal and air—this should be observable at smaller  $\theta_s$  and would provide an absolute measurement of the smectic-*A* order parameter; and (c) in the vicinity of the smectic-*A* to smectic-*B* phase, measurements in the specular direction along  $z$ , but at finite values of  $\tilde{Q}_\perp$ , should obtain information on structural correlations within the surface layers.<sup>11</sup>

The excellent research conditions provided by HASYLAB and the competent assistance of Risø technical staff members E. Dahl Petersen, S. Jørgensen, J. Linderholm, and J. Munck are gratefully acknowledged. This work was supported in part by grants from the Danish National Science Foundation, by the Risø National Laboratory, by the National Science Foundation under Grant No. DRM-79-19479, and by the Joint Services Electronics Program (U. S. Army, Navy, and Air Force) under Grant No. 14-75-C-0648.

<sup>(a)</sup>Work partly performed as a visiting scientist at Risø National Laboratory, DK-4000 Roskilde, Denmark.

<sup>1</sup>A review of x-ray and light scattering results in given in J. D. Litster, J. Als-Nielsen, R. J. Birgeneau, S. S. Dana, D. Davidov, F. Garcia-Golding, M. Kaplan,

C. R. Safinya, and R. Schaetzling, *J. Phys. (Paris), Colloq.* **40**, C3-339 (1979). Specific heat of 8OCB has been reported by D. L. Johnson, C. F. Hayes, R. J. de Hoff, and C. A. Schantz, *Phys. Rev. B* **18**, 4902 (1978); C. W. Garland, G. B. Kasting, and K. J. Lushington, *Phys. Rev. Lett.* **43**, 1420 (1979); J. D. Le-Grange and J. M. Mochel, *Phys. Rev. Lett.* **45**, 35 (1980). For a recent discussion of the N-*A* transition, see R. J. Birgeneau, C. W. Garland, G. B. Kasting, and B. M. Ocko, *Phys. Rev. A* **24**, 2624 (1981).

<sup>2</sup>D. R. Nelson and J. Toner, *Phys. Rev. B* **24**, 363 (1981); G. Grinstein and R. B. Pelcovitz, *Phys. Rev. Lett.* **47**, 856 (1981); S. G. Dunn and T. C. Lubensky, *J. Phys. (Paris)* **42**, 1201 (1981); C. Dasgupta and B. I. Halperin, *Phys. Rev. Lett.* **47**, 1556 (1981).

<sup>3</sup>A. Caillé, *C. R. Acad. Sci., Ser. B* **274**, 891 (1972).

<sup>4</sup>J. Als-Nielsen, J. D. Litster, R. J. Birgeneau, M. Kaplan, C. R. Safinya, A. Lindegaard-Andersen, and S. Mathiesen, *Phys. Rev. B* **22**, 312 (1980).

<sup>5</sup>P. S. Pershan, *J. Appl. Phys.* **45**, 1590 (1974); P. S. Pershan and J. Prost, *J. Appl. Phys.* **46**, 2343 (1975).

<sup>6</sup>Previous phenomenological studies involving free surface samples include D. Langevin, *Phys. Lett.* **56A**, 61 (1976); C. H. Sohl, K. Miyano, J. B. Ketterson, and G. Wong, *Phys. Rev. A* **22**, 1256 (1980); M. R. Fisch, L. B. Sorensen, and P. S. Pershan, *Phys. Rev. Lett.* **47**, 43 (1981); M. G. J. Gannon and T. W. Farber, *Philos. Mag. A* **37**.

<sup>7</sup>Surface-induced smectic ordering at temperatures for which the bulk phase is nematic was previously observed in freely suspended thin films by C. Rosenblatt and N. M. Amer, *Appl. Phys. Lett.* **36**, 432 (1980). It was also predicted on the basis of a lattice model by C. Rosenblatt and D. Ronis, *Phys. Rev. A* **23**, 305 (1981).

<sup>8</sup>P. G. de Gennes, *Solid State Commun.* **10**, 783 (1972), and *The Physics of Liquid Crystals* (Clarendon, Oxford, 1974).

<sup>9</sup>An identical analysis was independently given by H. v. Känel, J. D. Litster, J. Melngailis, and H. I. Smith, *Phys. Rev. A* **24**, 2713 (1981).

<sup>10</sup>This technique may also be applied to study the liquid-metal-vapor interface, c.f., M. P. D'Evelyn and S. A. Rice, *Phys. Rev. Lett.* **47**, 1844 (1981).

<sup>11</sup>P. Eisenberger and W. C. Marra, *Phys. Rev. Lett.* **46**, 1081 (1981).

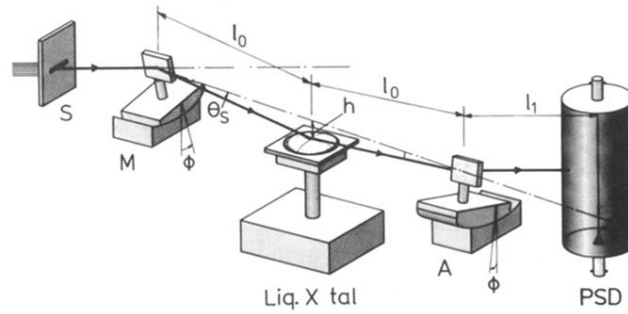

FIG. 1. Schematic illustration of the geometry for x-ray diffraction from a horizontal fluid surface. The slit  $S$  is  $0.1 \times 0.8 \text{ mm}^2$ ,  $l_0 = 575 \text{ mm}$ ,  $l_1 = 620 \text{ mm}$ , the wave vector  $k = 4.0786 \text{ \AA}^{-1}$ , and the Bragg vector for Si(111)  $\tau_{111} = 2.0039 \text{ \AA}^{-1}$ . Source-to-slit distance is 20 m.