

Production characteristics.—Finally we discuss the production mechanism for the $\rho(1630)$. Figure 3(c) shows the effective-mass plot of the $K(4\pi)^+$ system for the signal band before and after guard-band subtraction. There is an accumulation of events near threshold for the signal band only. We have fitted this and other related plots with a CLA model for Reaction (1) using the double peripheral diagrams also shown in Fig. 3(d) and the constants of Ref. 13. Possible exchange trajectories for the intercept of 0.5 are ρ , ω , A , and trajectories for the intercept of 0.3 are K^* and K^{**} . The one-dimensional distributions are fitted reasonably well and suggest that the threshold enhancement could be a kinematic effect, although the possibility that it could be a resonance is not ruled out.

We would like to thank the CERN proton synchrotron staff and the 2-m chamber crew for their help in obtaining the pictures. We are greatly indebted to Dr. P. Lazeyras and his colleagues who were responsible for the U5 beam. Thanks are also due to the Oxford University Film Analysis Group for their work on the earlier parts of the experiment. Lastly, we are grateful to the Science Research Council of Great Britain for their generous support.

†Accepted without review under policy announced in Editorial of 20 July 1964 [Phys. Rev. Letters 13, 79 (1964)].

¹G. Bellini *et al.*, Nuovo Cimento 40, 948 (1965).

²F. Conte *et al.*, Phys. Letters 22, 702 (1966).

³C. Baltay *et al.*, Phys. Rev. Letters 20, 887 (1968).

⁴N. N. Biswas *et al.*, Phys. Rev. Letters 21, 50 (1968).

⁵T. F. Johnston *et al.*, Phys. Rev. Letters 20, 1414 (1968).

⁶J. Ballam *et al.*, reported by B. French in *Proceedings of the Fourteenth International Conference on High Energy Physics, Vienna, Austria, September 1968*, edited by J. Prentki and J. Steinberger (CERN Scientific Information Service, Geneva, Switzerland, 1968).

⁷C. Caso *et al.*, reported by B. French in *Proceedings of the Fourteenth International Conference on High Energy Physics, Vienna, Austria, September 1968*, edited by J. Prentki and J. Steinberger (CERN Scientific Information Service, Geneva, Switzerland, 1968).

⁸W. J. Kernan, D. E. Lyon, and H. B. Crawley, Phys. Rev. Letters 15, 803 (1965).

⁹J. A. Danysz *et al.*, Phys. Letters 24B, 309 (1967).

¹⁰A. H. Rosenfeld *et al.*, Rev. Mod. Phys. 42, 1 (1970).

¹¹M. N. Focacci, W. Kienzle, B. Levrat, B. C. Maglič, and M. Martin, Phys. Rev. Letters 17, 890 (1966).

¹²The corresponding cross section after corrections for scanning losses, invisible decays, etc., are 817 ± 110 , $1090 \pm 115 \mu\text{b}$ for Reactions (2) and (3), and $62 \pm 8 \mu\text{b}$ for Reaction (4) uncorrected for invisible decays.

¹³H. M. Chan, J. Loskiewicz, and W. W. M. Allison, Nuovo Cimento 57A, 93 (1968).

¹⁴Figure 3(a) was fitted with a smooth hand-drawn background and Breit-Wigner resonance. The background to Fig. 3(b) was calculated for the process $K^+p \rightarrow K^0\omega\pi^+p$ using the model of Ref. 13. This background peaks near 1100 MeV and it was necessary to include both the B meson and $\rho(1630)$ to obtain a good overall fit.

LIMIT ON THE $K^+ \rightarrow \pi^+ + \nu + \bar{\nu}$ DECAY RATE*

J. H. Klems and R. H. Hildebrand

Lawrence Radiation Laboratory and University of Chicago, Chicago, Illinois 60637

and

R. Stiening

Lawrence Radiation Laboratory, University of California, Berkeley, California 94707

(Received 27 March 1970)

The branching ratio for the process $K^+ \rightarrow \pi^+ + \nu + \bar{\nu}$ is shown by a counter spark chamber experiment to be less than 1.2×10^{-6} of all decay modes, assuming a pion energy spectrum like that of $K^+ \rightarrow \pi^0 + e^+ + \nu$. Our apparatus was sensitive to pions in the kinetic energy range 117–127 MeV.

In 1964 Camerini, Cline, Fry, and Powell¹ reported the results of a search for the reaction $K^+ \rightarrow \pi^+ + e^+ + e^-$. They set an upper limit of 2.5×10^{-6} on the branching ratio for this decay mode. Other experiments² have been made to search for $K_L^0 \rightarrow e^+ + e^-$, $K_{L,S}^0 \rightarrow \mu^+ + \mu^-$, and $K^+ \rightarrow \pi^+ \mu^+ \mu^-$.

These decays have not been observed. In the experiment described here, we have searched for the decay

$$K \rightarrow \pi^+ + \nu + \bar{\nu}. \quad (1)$$

We have observed no examples of this decay. If

we assume that the energy spectrum of the π^+ is the same as that of the π^0 in the observed reaction³ $K^+ \rightarrow \pi^0 + e^+ + \nu$, we can set an upper limit on the branching ratio⁴ for the K^+ to decay in this manner of 1.2×10^{-6} (90% confidence level).

The significance of our result depends upon the manner in which we account for the absence of the reactions discussed above. We may suppose that $K^+ \rightarrow \pi^+ + \nu + \bar{\nu}$ should result from the same interaction that gives rise to $K^+ \rightarrow \pi^0 + e^+ + \nu$. The matrix element for this latter decay is known to be of the form⁵

$$2^{-1/2}G[\bar{U}_\nu \gamma_\lambda (1 + \gamma_5) U_e] \langle \pi^0 | J_\lambda | K^+ \rangle. \quad (2)$$

If we substitute $\langle \pi^+ | J_\lambda | K^+ \rangle$ for $\langle \pi^0 | J_\lambda | K^+ \rangle$ and $\bar{U}_\nu \gamma_\lambda (1 + \gamma_5) U_\nu$ for $\bar{U}_\nu \gamma_\lambda (1 + \gamma_5) U_e$, and if $\langle \pi^+ | J_\lambda | K^+ \rangle = \langle \pi^0 | J_\lambda | K^+ \rangle$, the above expression for the matrix element is practically unchanged. The energy release in the decay is so high that the electron mass is negligible. That our upper limit on the branching ratio for $K^+ \rightarrow \pi^+ + \nu + \bar{\nu}$ is at most very small in comparison with the branching ratio for $K^+ \rightarrow \pi^0 + e^+ + \nu$ (which is 0.05) can be accounted for by assuming either that $\langle \pi^+ | J_\lambda | K^+ \rangle$ vanishes or that some lepton selection rule is violated by a current $\bar{U}_\nu \gamma_\lambda (1 + \gamma_5) U_\nu$.

The current J_λ is known empirically to obey the $\Delta I = \frac{1}{2}$ rule. If we assume that the $\langle \pi^+ | J_\lambda | K^+ \rangle$ component of this current vanishes, it is impossible to account for the $\Delta I = \frac{1}{2}$ selection rule of nonleptonic strange particle decays in the usual fashion as the result of a current-current interaction where one current carries $\Delta I = \frac{1}{2}$, $\Delta S = 1$, and the other carries $\Delta I = 1$, $\Delta S = 0$. Thus it is necessary to abandon the hypothesis that all weak interactions occur as the self-interaction of a current made up of many parts. Our experiment is consistent with the assumption that the matrix element $\langle \pi^+ | J_\lambda | K^+ \rangle$ vanishes since both $K^+ \rightarrow \pi^+ + e^+ + e^-$ and $K^+ \rightarrow \pi^+ + \nu + \bar{\nu}$ would then vanish. On the other hand, if $\langle \pi^+ | J_\lambda | K^+ \rangle \neq 0$ there must be a selection rule among leptons which prohibits currents of the form $\bar{U}_\nu \gamma_\lambda (1 + \gamma_5) U_e$. Our experiment then shows that the combination $\bar{U}_\nu \gamma_\lambda (1 + \gamma_5) U_\nu$ is also forbidden. It is impossible to decide at present whether it is this leptonic current or the hadronic current matrix element $\langle \pi^+ | J_\lambda | K^+ \rangle$ that vanishes.

Oakes⁶ has suggested that although $K^+ \rightarrow \pi^+ + \nu + \bar{\nu}$ may occur in the framework of conventional weak-interaction theory for one of the reasons discussed above, there may be an additional type of weak-interaction current which does not conserve CP and gives rise to $K_2^0 \rightarrow 2\pi$ decay. The

branching ratio⁷ for $K^+ \rightarrow \pi^+ + \nu + \bar{\nu}$ in the theory of Oakes is 1.8×10^{-5} . Our result is inconsistent with this prediction. Other authors⁸ have calculated $K^+ \rightarrow \pi^+ + \nu + \bar{\nu}$ on the basis of higher order weak-interaction theories. A simple second-order application of weak-interaction theory as it is now known leads to a divergent result for the $K^+ \rightarrow \pi^+ + \nu + \bar{\nu}$ decay rate. Various models have been made to ameliorate the difficulties caused by this divergence.⁸ The interpretation of our result hinges then on details of the model employed.

The experiment depends on the fact that no observed K^+ decay at rest produces a π^+ with an energy greater than that from $K^+ \rightarrow \pi^+ + \pi^0$ ($T_\pi = 109$ MeV; branching ratio = 0.21). In order to produce a π^+ of higher energy the K^+ must decay into a π^+ and a neutral system with rest mass less than that of the π^0 . If we neglect decays into four or more particles, the only possibilities are $K^+ \rightarrow \pi^+ + e^+ + e^-$ (branching ratio $< 2.5 \times 10^{-6}$),¹ $K^+ \rightarrow \pi^+ + \gamma + \gamma$ (branching ratio $< 1.1 \times 10^{-4}$),⁹ and Reaction (1). The last two reactions may give pions with energies up to 127 MeV. Hence that we observe no π^+ emitted with energy between 117 and 127 MeV unaccompanied by high-energy γ 's or charged particles in the opposite hemisphere is sufficient to exclude the $\pi^+ \nu \bar{\nu}$ decay.

The experimental arrangement is shown in Fig. 1. Kaons in the incoming beam from the Beva-

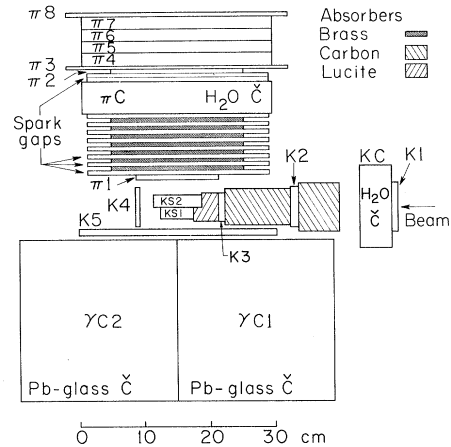

FIG. 1. Apparatus. Kaons stopping in the target scintillators KS1 and KS2 are selected from the incoming beam by signals K1, $\bar{K}C$, K2, K3, KS1 and/or KS2, $\bar{K}4$, $\bar{K}5$, where K2 and K3 have pulse heights $\geq 1.5 \times$ (pion pulse height). Low-velocity decay particles are selected by signals $\pi 1$, $\bar{\pi}C$, $\pi 2$, $\pi 3$, $\bar{\pi}8$, $\bar{K}C$, $\bar{K}4$, $\bar{K}5$, where $\pi 1$ is delayed ≥ 6 nsec after K3. Events which emit gammas into the opposite hemisphere are eliminated by signals $\gamma C1$ and/or $\gamma C2$. Pions are distinguished from stopping muons by scope displays of the $\pi-\mu-e$ decay pulses in counters $\pi 4-\pi 7$.

tron are brought to rest in the "K-stop" counters *KS1* and *KS2*. Scattered and transmitted particles are suppressed by the anticoincidence counters *K4* and *K5*. Those scattered toward the π counters are suppressed by the requirement that the pulses from counters $\pi 1$ and $\pi 2$ must be delayed ≥ 6 nsec after the pulse from the stopping *K*. Pions in the beam are excluded by (i) a water Cherenkov counter *KC* [actually consisting of two counters connected in parallel: $\beta(K) < \beta(\text{threshold}) < \beta(\pi)$], (ii) two dE/dX counters [$(dE/dX)_K > 1.5(dE/dX)_\pi$], and (iii) range ($R_\pi \gg R_K$ for the same initial momentum). In summary the K^+ signal is [*K1*, *K2*, *K3*, *KS1* and/or *KS2*, \overline{KC} , $\overline{K4}$, $\overline{K5}$]. We require that a subsequent π signal occur between 6 and 54 nsec after the K^+ signal, and we denote the K^+ signal together with this additional timing requirement as the "K-decay" signal.

The triggering system of the π^+ detector ($\pi 1$, $\overline{\pi C}$, $\pi 2$, $\pi 3$, $\overline{\pi 8}$, \overline{KC} , $\overline{K4}$, $\overline{K5}$) does not distinguish between stopping π 's and stopping μ 's, but high-velocity μ 's from $K_{\mu 2}$ are vetoed by the water Cherenkov counter πC and by the maximum-range counter $\pi 8$. A large counter, *KO*, which completely covers the incoming beam (not shown in Fig. 1) is used to detect events in which more than one beam particle enters the apparatus during the $K \rightarrow \pi \rightarrow \mu \rightarrow e$ decay sequence. These events are excluded if a beam particle enters in coincidence with the π , μ , or e . The requirement \overline{KC} in the π^+ triggering system further insures against detecting scattered beam pions.

Whenever the whole triggering system ("K decay," π , and γ) indicates that a K^+ has stopped in the target, that later a slow charged particle has passed through the π telescope and stopped in one of the decay counters $\pi 4$ to $\pi 7$, and that no high-energy γ has entered the lead-glass Cherenkov counters $\gamma C 1$ or $\gamma C 2$, then the spark chambers are pulsed and the signals from the decay counters are displayed on each of two four-beam oscilloscopes. One of the oscilloscopes has a sweep range of 200 nsec. The four traces on this oscilloscope are examined for the stopping π^+ and the $\pi^+ \rightarrow \mu^+$ decay. The μ^+ energy loss is determined by measuring the μ^+ pulse height. Since the μ^+ in $\pi^+ \rightarrow \mu^+ + \nu$ decay has an energy of 4.4 MeV, this measurement is helpful in eliminating accidental backgrounds. The other oscilloscope has a sweep range of 3 μ sec. The traces on this oscilloscope are examined for the $\mu^+ \rightarrow e^+$ decay. We require that an e^+ pulse occur in the counter in which the π^+ stopped, and that

either the e^+ have an energy loss of > 4.5 MeV in that counter or that it make a pulse in at least one adjacent counter.

The pion range is computed using the absorber thickness (which is varied according to the portion of the spectrum to be examined), the pion trajectory as seen in the spark gaps, and the positions of the counters showing the *K* stop and the π decay.

The $K^+ \rightarrow \pi^+ + \pi^0$ decays are used to calibrate the apparatus. The measured pion mean life using pions from $K^+ \rightarrow \pi^+ + \pi^0$ is 26.4 ± 1.0 nsec in good agreement with the accepted value. The inefficiency of the γC anticoincidence counters (determined by comparing the $K^+ \rightarrow \pi^+ + \pi^0$ event rates with γ 's vetoed versus the rate with γ 's required) is 6×10^{-4} . The branching ratio ($K^+ \rightarrow \pi^+ + \pi^0$)/($K^+ \rightarrow \mu^+ + \nu$) is found to be 0.36 ± 0.03 in satisfactory agreement with the accepted value 0.33. This agreement checks the assumed value for π^+ absorption.

Events with an apparent $\pi^+ \rightarrow \mu^+ \rightarrow e^+$ decay sequence and with a π^+ range of at least 50 g cm^{-2} were considered " $K^+ \rightarrow \pi^+ + \nu + \bar{\nu}$ " events. The most important source of background was $K^+ \rightarrow \mu^+ + \nu + \gamma$ events where an accidental particle struck the decay counters causing the $\mu \rightarrow e$ decay to be mistaken for a $\pi \rightarrow \mu \rightarrow e$ decay sequence. The probability of this was determined by examining a sample of 30 000 stopping μ^+ from $K^+ \rightarrow \mu^+ + \nu$ for apparent $\pi \rightarrow \mu \rightarrow e$ decays. The range of the stopping particles ($R > 70 \text{ g cm}^{-2}$) guaranteed that they could not be pions. Most of the spurious " π " " μ " $\rightarrow e$ events were found to have low " μ " pulse heights. The same probability for spurious events was assumed for the 32 000 stopping μ^+ (from $K^+ \rightarrow \mu^+ + \nu + \gamma$) seen during the search for $K^+ \rightarrow \pi^+ + \nu + \bar{\nu}$ ($50 \leq R \leq 59 \text{ g cm}^{-2}$). Another source of background was due to pions in the *K* beam which the *KC* counter failed to veto.

The numbers of " $K^+ \rightarrow \pi^+ + \nu + \bar{\nu}$ " events and the expected background events were considered for various cutoff values of the *K* lifetime, the π lifetime, and the " μ " pulse height. The numbers of " $K^+ \rightarrow \pi^+ + \nu + \bar{\nu}$ " were consistent with the expected background for a wide variety of cutoff values. In the final sample of " $K^+ \rightarrow \pi^+ + \nu + \bar{\nu}$ " events " μ " pulses were required to have between 0.5 and 1.5 times the mean pulse height of muons from $\pi \rightarrow \mu$ decays. The π and *K* lifetimes were required to be within two mean lives after our detection thresholds. Measurement with $K^+ \rightarrow \pi^+ + \pi^0$ events showed that these cuts excluded 33% of the pions. After the cuts the expected background is 0.8

events. There were no “ $K^+ \rightarrow \pi^+ + \nu + \bar{\nu}$ ” events in the final sample.

Our detector efficiency for $\pi^+ \nu \bar{\nu}$ events is shown in curve II of Fig. 2(a). The meaning of observing one event in our experiment depends on the convolution of this efficiency and an assumed pion spectrum. We denote this convolution by $\epsilon_{\pi^+ \nu \bar{\nu}}$. We have considered the possibilities shown in Table I.

Assuming a vector interaction if one event had been found, the branching ratio would have been

$$\frac{\Gamma(K^+ \rightarrow \pi^+ + \nu + \bar{\nu})}{\Gamma(\text{all modes})} = \frac{(\pi^+ \nu \bar{\nu})/K^+}{(\pi^+ \pi^0)/K^+} \frac{\epsilon_{\pi^+ \pi^0} T_I}{\epsilon_{\pi^+ \nu \bar{\nu}} T_{II}} \times \frac{\Gamma(\pi^+ \pi^0)}{\Gamma(\text{all modes})} = 5.3 \times 10^{-7}. \quad (3)$$

Here $\pi^+ \nu \bar{\nu}/K^+$ stands for the ratio of the number of “ $K^+ \rightarrow \pi^+ + \nu + \bar{\nu}$ ” events found to the number of K^+ signals examined by the triggering system (7.2×10^{-10} assuming 1 event); $\pi^+ \pi^0/K^+$ is the ratio of the number of $\pi^+ \pi^0$ events found to the number of K^+ signals examined when the apparatus was used to detect $K^+ \rightarrow \pi^+ \pi^0$ (1.5×10^{-3}); $\epsilon_{\pi^+ \pi^0}$

Table I. Effective detection efficiency $\epsilon_{\pi^+ \nu \bar{\nu}}$ (117 MeV $\leq T_\pi \leq 127$ MeV) and resultant branching ratio (90% confidence level) for several assumed π^+ spectra. p_π and T_π are the momentum and kinetic energy, respectively, of the π^+ . $T_{\text{max}} = 127$ MeV is the kinematic upper limit for $K^+ \rightarrow \pi^+ + \nu + \bar{\nu}$. The spectra were normalized to have unit area between 0 and T_{max} .

$\frac{dN}{dT_\pi}$ assumed	Type of first-order interaction	$\epsilon_{\pi^+ \nu \bar{\nu}}$	Branching ratio
p_π^3	vector	0.0105	1.2×10^{-6}
$p_\pi^3(T_{\text{max}} - T_\pi)$	tensor	0.0034	3.8×10^{-6}
$p_\pi(T_{\text{max}} - T_\pi)$	scalar	0.00072	1.8×10^{-5}

(0.054) is the detection efficiency for $\pi^+ \pi^0$ [the convolution of curve I with curve (i) in Fig. 2(a)]; $\epsilon_{\pi^+ \nu \bar{\nu}}$ (0.0105) is the detection efficiency for $\pi^+ \nu \bar{\nu}$ assuming a vector spectrum [the convolution of curve II with curve (ii) in Fig. 2(a)]; and T_I/T_{II} (1.05) is the ratio of π^+ transmissions for the absorbers corresponding to curves I and II in Fig. 2(a) (44 and 52 g cm⁻² Cu equivalent, respectively).

Table I contains the branching ratios which we infer from (3). By the 90% confidence level we mean the rate which we would compute had we found 2.3 events.

We are grateful to Professor E. Segrè for his encouragement and support and to Dr. C. Wiegand and D. Brandshaft for valuable assistance, especially in the early stages of this experiment. We also wish to thank W. Davis, J. Gallup, N. Green, E. Hahn, D. Hildebrand, P. Newman, and J. Wild for their help with scanning, analysis, and operation. One of us (RHH) wishes to acknowledge with thanks his support by the John Simon Guggenheim Foundation during the course of this experiment.

FIG. 2. Range distributions. (a) Calculated distributions for K^+ decays into $\pi^+ \pi^0$, $\pi^+ \nu \bar{\nu}$ (vector), and $\mu^+ \nu$ with straggling and small-angle multiple scattering taken into account. Dashed curves I, II, and III show detector efficiencies for different absorber thicknesses (curve II is weighted sum of curves corresponding to two nearly equal thicknesses). (b) Expected event distributions for $\pi^+ \pi^0$ and $\mu^+ \nu$ (curves I and III folded into i and iii) and corresponding observed distributions (histograms). (c) Expected and observed $\pi^+ \pi^0$ and “ $\pi^+ \nu \bar{\nu}$ ” distributions for absorber corresponding to curve II, (a). [$\gamma C1$ and/or $\gamma C2$ required in coincidence for $\pi^+ \pi^0$ (open histogram) and in anticoincidence for “ $\pi^+ \nu \bar{\nu}$ ” (shaded histogram).]

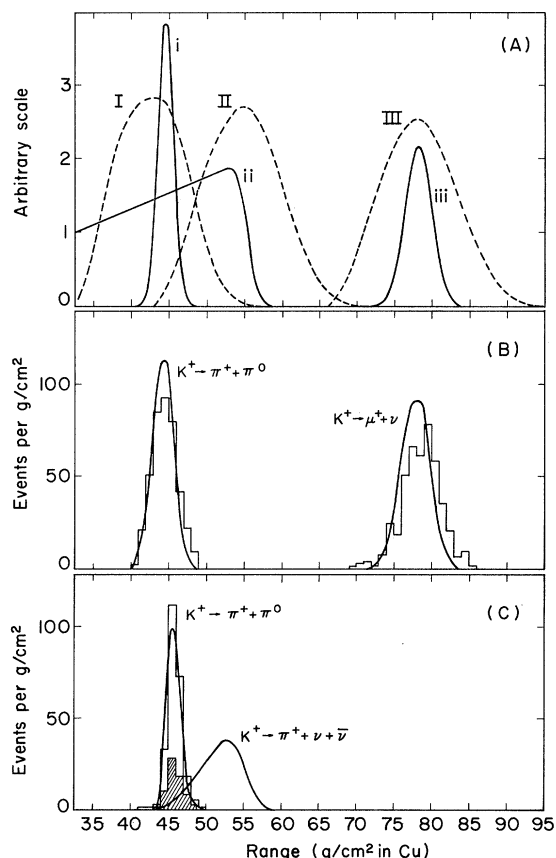

*Research supported by the U. S. Atomic Energy Commission and by the National Science Foundation Grant No. Gp 14521.

¹U. Camerini, D. Cline, W. F. Fry, and W. M. Powell, Phys. Rev. Letters 13, 318 (1964).

²Branching ratio limits (90% confidence level): $K_L^0 \rightarrow e^+ + e^- < 1.5 \times 10^{-7}$, $K_L^0 \rightarrow \mu^+ + \mu^- < 2.1 \times 10^{-7}$, H. Foeth *et al.*, Phys. Letters 30B, 282 (1969); $K_S^0 \rightarrow \mu^+ + \mu^- < 7.3 \times 10^{-6}$, B. D. Hyams *et al.*, Phys. Letters 29B, 521 (1969); $K^+ \rightarrow \pi^+ + \mu^+ + \mu^- < 2.4 \times 10^{-6}$, V. Bisi, R. Cester, A. Marzari Chiesa, and M. Vigone, Phys. Letters 25B, 572 (1967). See also D. W. Carpenter *et al.*, Phys. Rev. 142, 871 (1966); C. Alff-Steinberger *et al.*, Phys. Letters 21, 595 (1966); Camerini, Cline, Fry, and Powell, Ref. 1; and U. Camerini, D. Ljung, M. Sheaff, and D. Cline, Phys. Rev. Letters 23, 326 (1969).

³For a compilation of the experimental results on

this reaction see Particle Data Group, Rev. Mod. Phys. 42, 87 (1970).

⁴Previous upper limit: $K^+ \rightarrow \pi^+ + \nu + \bar{\nu} < 1.0 \times 10^{-4}$ per K^+ decay (90% confidence level), see Camerini, Ljung, Sheaff, and Cline, Ref. 2.

⁵P. Dennery and H. Primakoff, Phys. Rev. 131, 1334 (1963).

⁶R. J. Oakes, Phys. Rev. Letters 20, 1539 (1968).

⁷R. J. Oakes, Phys. Rev. 183, 1520 (1969).

⁸In a model containing a massive neutral muon-type lepton G. Segrè [Phys. Rev. 181, 1996 (1969)] estimates the branching ratio ($K^+ \rightarrow \pi^+ + \nu + \bar{\nu}$) $\approx [10^{-4} \times \text{branching ratio } (K^+ \rightarrow \pi^0 + e^+ + \nu)] \approx 5 \times 10^{-6}$. See also N. Christ, Phys. Rev. 176, 2086 (1968), and M. Gell-Mann, M. L. Goldberger, N. M. Kroll, and F. E. Low, Phys. Rev. 179, 1518 (1969).

⁹M. Chen, D. Cutts, P. Kijewski, R. Stiening, C. Wiegand, and M. Deutsch, Phys. Rev. Letters 20, 73 (1968).