

PHYSICAL REVIEW LETTERS

VOLUME 22

16 JUNE 1969

NUMBER 24

DECAY OF THE $(2s^2 2p)^2 P$ COMPOUND STATE IN HELIUM BY TWO-ELECTRON EMISSION*

P. D. Burrow and G. J. Schulz

Mason Laboratory, Yale University, New Haven, Connecticut 06520

(Received 9 May 1969)

Compound states of atoms are known to decay by the emission of a single electron into many states lying at lower energies. Compound states associated with doubly excited states lie at energies above the ionization potential, and therefore the decay into an ion by the emission of two electrons is energetically possible. This paper presents evidence for such a two-electron decay in the case of the $(2s^2 2p)^2 P$ compound state of helium which derives from the $(2s^2)^1 S$ atomic state.

Resonances associated with the existence of compound states, i.e., temporary negative ion states, above the ionization potential of helium are well established. These resonances, located near 57 and 58 eV, are associated with doubly excited states of helium. They were first observed by Kuyatt, Simpson, and Mielczarek¹ in the total scattering cross section using a transmission experiment. The same resonances were subsequently observed in three inelastic-decay channels by Simpson, Menendez, and Mielczarek.² We report here the observation that one of these compound states can decay into $\text{He}^+ + 2e$ by the simultaneous emission of two electrons. Although decay of compound states by two-particle emission has been reported for nuclear reactions,³ it has not been observed previously for atomic systems.

Figure 1 shows the relative positions and electronic configurations of two of the lower doubly excited states⁴ of helium and the two known compound states.⁵ The configuration assignment of the resonances was first made by Fano and Cooper.⁶ The "parent" of the $(2s^2 2p)^2 P$ compound state is the lowest doubly excited $(2s^2)^1 S$ state at 57.82 eV. This is analogous to the $(1s2s^2)^1 S$ resonance⁷ at 19.3 eV and its "parent" singly excited

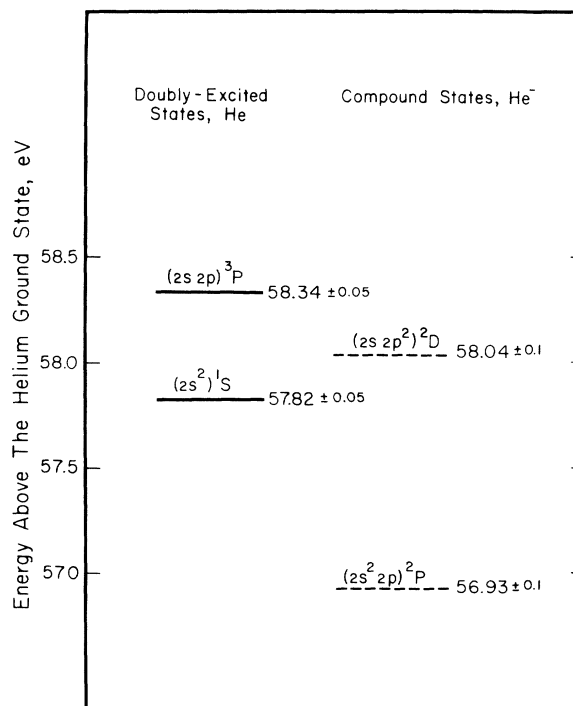

FIG. 1. Location of the lowest doubly excited states and the associated compound states.

$(1s2s)^3S$ state at 19.8 eV. Because the $(2s^22p)^2P$ resonance lies above all singly excited states of helium, numerous decay channels accompanied by the ejection of a single electron are available. In particular, the resonances have been observed in the excitation functions of the $(1s2s)^3S$, $(1s2s)^1S$, and $(1s2p)^1P$ states, but not in the elastic channel.² Decay into $He^+ + 2e$ is an additional decay channel which is energetically allowed.

I. Experiment.—We have applied the trapped-electron method⁸ to the study of excitation processes lying above the ionization potential. This method, which provides a sensitive technique for the study of slow electrons (0.0–0.1 eV) produced in collisions, has been previously described.^{8,9} Only a brief account is given here.

A diagram of the trapped-electron tube and the potential along the axis is shown in Fig. 2. An electron beam, collimated by an axial magnetic field of 240 G, is accelerated into a collision chamber. The collision chamber consists of two end plates and a highly transparent, axially symmetric grid. Surrounding the grid is a cylindrically shaped collector. The collector is biased positively with respect to the collision chamber. This produces a potential well, whose depth may be varied, along the axis of the tube. Electrons making inelastic collisions near the threshold of a process lose almost all of their kinetic energy. These electrons cannot pass through the potential barrier at the end plates. They move along the lines of the magnetic field and eventually migrate to the trapped-electron collector by means of elastic collisions. Once the incident energy exceeds that of the inelastic threshold by more than the well depth, the scattered electrons are too energetic to be trapped, and the trapped-electron

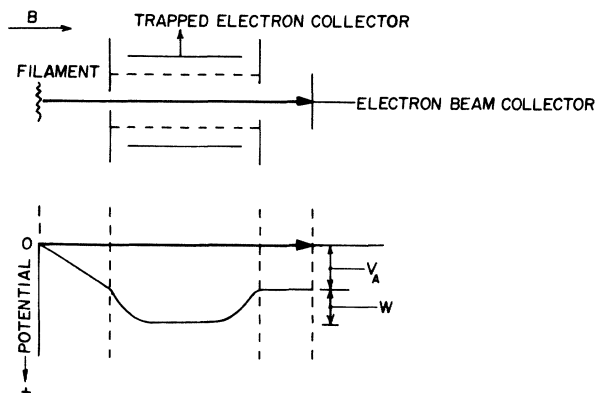

FIG. 2. Schematic diagram of the trapped-electron tube and the potential distribution along the path of the electron beam.

current vanishes. In summary, as a function of incident energy, the trapped-electron current is zero below the threshold of an inelastic process, rises to a peak at an energy above threshold equal to the well depth, and then falls to zero.

Operation above the ionization potential produces a large background of trapped-electron current resulting from excitation to the ionization continuum. The positive ions are produced with thermal energies and cannot reach the positively biased trapped-electron collector. The background current is relatively constant in the energy range of interest and is largely suppressed.

II. Results.—Figure 3 shows a plot of the trapped-electron current, taken with a well depth of 0.1 eV, in the region of the lowest two, optically forbidden, doubly excited states of helium. The height of the two peaks is proportional to the cross section for excitation of the $(2s^2)^1S$ and $(2s2p)^2P$ states at 0.1 eV above their thresholds. We have used the onset for excitation to the $(2s2p)^3P$ state to calibrate our energy scale within ± 0.1 eV. The energy of this state has been calibrated by Rudd⁴ against an optically allowed state which is located with high accuracy by spectroscopic means.¹⁰ The $(2s^2)^1S$ state is not suitable for the calibration of the electron energy scale because it has a large half width.¹¹

The feature of interest is the dip in the background current lying below the lowest doubly excited state. The dip comprises approximately

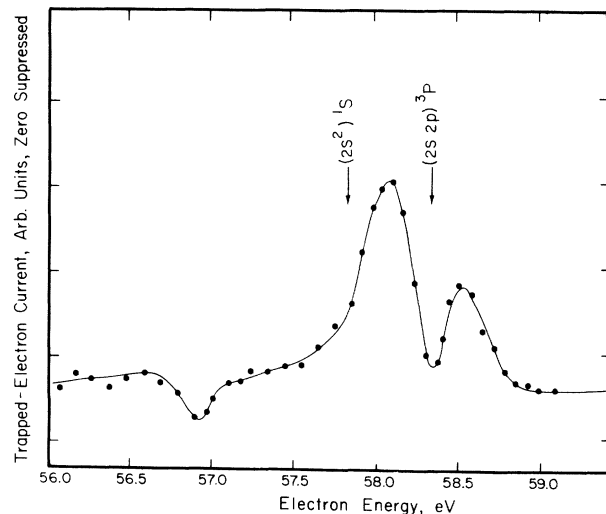

FIG. 3. Current of trapped-electron versus electron energy. The dip near 56.9 eV is interpreted as the $(2s^22p)^2P$ resonance decaying into $He^+ + 2e$. The two peaks at higher energy are the lowest doubly excited states.

1% of the trapped-electron current due to direct ionization. Within the range of calibration errors, this structure lies at the same energy as the $(2s^2 2p)^2 P$ resonance found by Kuyatt, Simpson, and Mielczarek.¹ When the temporary negative ion decays into a singly excited state by the ejection of a single electron, the ejected electron has a kinetic energy in excess of 32.5 eV. Such an electron does not contribute to the trapped-electron current because it is too energetic to be trapped. However, when decay to the helium positive ion by the emission of two electrons takes place, and one of the electrons has low energy, a contribution to the trapped-electron current results. Structure due to the resonance, therefore, can only appear in the present experiment from that fraction of the two-electron emission events in which one electron has less than 0.1 eV of kinetic energy.

Because the compound state is coupled to the continuum we expect the density of continuum states near the resonance to be perturbed. The total production of slow electrons from both direct ionization and the resonance will exhibit interference effects analogous to those found by Madden and Codling¹⁰ for the optically allowed doubly excited states which decay by autoionization.¹² The trapped-electron current at the resonance may in principle decrease, as observed here, or increase.

With the well depth used for obtaining Fig. 3, the upper resonance $(2s 2p^2) D$ falls near the peak for excitation to the $(2s^2)^1 S$ state and is not easily observed. A trace similar to that of Fig. 3 was

taken with a larger well depth, which serves to shift the peaks of the doubly excited states to higher energy. Such a plot reveals the upper resonance more clearly. Although this compound state may also decay by two-electron emission, the interpretation is not straightforward since the upper resonance may also appear as structure in the excitation function of the $(2s^2)^1 S$ state.

*Work supported by the National Science Foundation.

¹C. E. Kuyatt, J. A. Simpson, and S. R. Mielczarek, *Phys. Rev.* **138**, A385 (1965).

²J. A. Simpson, M. G. Menendez, and S. R. Mielczarek, *Phys. Rev.* **150**, 76 (1966).

³J. M. Blatt and V. F. Weisskopf, *Theoretical Nuclear Physics* (John Wiley & Sons, Inc., New York, 1952), p. 374.

⁴The energies of the doubly excited states are taken from M. E. Rudd, *Phys. Rev. Letters* **15**, 580 (1965). They are believed to be accurate within about 0.05 eV.

⁵We have positioned the compound states in Fig. 1 at 56.93 ± 0.1 and 58.04 ± 0.1 eV according to the energy calibration discussed in the text. The authors of Ref. 1 locate them somewhat higher, namely, at 57.1 ± 0.1 and 58.2 ± 0.1 eV.

⁶U. Fano and J. W. Cooper, *Phys. Rev.* **138**, A400 (1965).

⁷G. J. Schulz, *Phys. Rev. Letters* **10**, 104 (1963).

⁸G. J. Schulz, *Phys. Rev.* **112**, 150 (1958).

⁹G. J. Schulz, *Phys. Rev.* **116**, 1141 (1959).

¹⁰R. P. Madden and K. Codling, *Astrophys. J.* **141**, 364 (1965).

¹¹P. G. Burke, in *Advances in Atomic and Molecular Physics*, edited by D. R. Bates and I. Estermann (Academic Press, Inc., New York, 1968), Vol. 4, p. 209.

¹²U. Fano, *Phys. Rev.* **124**, 1866 (1961).

EXPERIMENTAL VALUE OF $\Delta E_H - \mathcal{S}_H$ IN HYDROGEN*

T. W. Shyn, W. L. Williams, R. T. Robiscoe,† and T. Rebane
Harrison M. Randall Laboratory of Physics, Ann Arbor, Michigan 48104
(Received 5 May 1969)

We have measured the $2^2S_{1/2} - 2^2P_{3/2}$ separation, $\Delta E_H - \mathcal{S}_H$, in atomic hydrogen by an atomic-beam rf method. We find $\Delta E_H - \mathcal{S}_H = 9911.213 \pm 0.058$ MHz. The quoted error is 1 average deviation from the mean for 115 line centers.

We have measured the $2^2S_{1/2} - 2^2P_{3/2}$ separation, $\Delta E_H - \mathcal{S}_H$, in atomic hydrogen. We employed an atomic-beam rf method using metastable $2^2S_{1/2}$ atoms. The method is similar to that used by Lamb and co-workers.¹ We have incorporated two important modifications which were introduced by Robiscoe² and Cosens.³ First, the atomic-beam trajectory is essentially parallel

to the direction of the dc magnetic field in which the rf transitions take place. This reduces Stark quenching of the metastable H atoms due to motional electric fields, which can cause asymmetries in the resonance lines. If the Stark quenching is large, it is necessary to know the velocity distribution of the atoms in the beam. We have found that with the electron-bombardment con-