

Dynamical Picture for the Formation and Decay of the Exotic XYZ Mesons

Stanley J. Brodsky*

SLAC National Accelerator Laboratory, Stanford University, Stanford, California 94039, USA

Dae Sung Hwang†

Department of Physics, Sejong University, Seoul 143-747, South Korea

Richard F. Lebed‡

Department of Physics, Arizona State University, Tempe, Arizona 85287-1504, USA

(Received 8 July 2014; published 10 September 2014)

We present a new dynamical picture that identifies the formation of the exotic $\bar{c}c$ -containing states XYZ with the confinement-induced hadronization of a rapidly separating pair of a compact diquark and antidiquark. This picture combines the advantages of diquark-based models, which can accommodate much of the known XYZ spectrum, with the experimental fact that such states are both relatively narrow and are produced promptly. It also naturally explains the preference of some of the exotic states to decay to $\psi(2S)$, rather than J/ψ , in terms of a simple wave-function overlap effect.

DOI: 10.1103/PhysRevLett.113.112001

PACS numbers: 14.40.Rt, 12.39.-x, 12.39.Mk, 14.40.Pq

The 2003 Belle discovery [1] of an unusual charmoniumlike state, appearing as a resonance of $\pi^+\pi^-J/\psi$ and now called $X(3872)$, has led to the observation of numerous related states during the past decade [2] at Belle, BaBar, CDF, D0, CLEO, CMS, LHCb, and BESIII. Indeed, the BESIII experiment continues to present evidence for new exotic states even in the past few months [3]. These states do not fit into the standard nonrelativistic quark model of a single $\bar{c}c$ pair with separation r interacting via a potential $V(r)$, which had been successful in accommodating all of the previously known charmonium states [4–6]; instead, they are believed to be tetraquark ($\bar{c}c\bar{q}q'$) states currently named X , Y , or Z (In the current nomenclature, the neutral (charged) states observed in B decays are labeled $X(Z)$, whereas the Y are the neutral, $J^{PC} = 1^{--}$ states observed in initial-state radiation e^+e^- processes). Notable evidence supporting this identification includes the facts that $X(3872)$ is an extremely narrow ($\Gamma < 1.2$ MeV) $J^{PC} = 1^{++}$ state but is tens of MeV lighter than the nearest quark-model candidate $\chi_{c1}(2P)$ [6], and the recent confirmation at LHCb [7] of the charged $J^P = 1^+$ state $Z(4430)$ as a resonance decaying into $\pi^-\psi(2S)$. This first verification of the existence of exotic hadrons, which possess neither meson ($\bar{q}q$) nor baryon (qqq) valence structure, is an exciting advance for QCD; a key challenge is to uncover the dynamical structure of these states.

One can imagine the binding of a $(\bar{q}_1q_2\bar{q}_3q_4)$ state to occur in a variety of ways. First, the four valence quarks can all interact democratically, which one may call a “true” tetraquark. However, simple SU(3) color group theory shows that the combination of two quarks (each a color $\mathbf{3}$) and two antiquarks (each a color $\bar{\mathbf{3}}$) can form an overall color singlet in only two independent ways—matching the color structure of factorized two-meson states $(\bar{q}_1q_2)(\bar{q}_3q_4)$

and $(\bar{q}_1q_4)(\bar{q}_3q_2)$. In large N_c QCD, this fact has long been used to argue that narrow tetraquark states do not occur, since the four-quark source operators needed to create them are saturated by two-meson states. Weinberg has recently showed [8] that this argument contains a loophole; however, his scenario requires modifications that go beyond the usual large N_c counting rules and structures [9–11].

The color factorization property of the tetraquark naively suggests a two-meson molecule structure for the observed states. Indeed, many of the XYZ states lie close to such thresholds (e.g., $m_{X(3872)} \approx m_D + m_{D^*} \approx m_{J/\psi} + m_\omega$), suggesting a molecule with a small binding energy E_b via a van der Waals-type attraction [12]. However, the typical scattering length of such a state is given by its Compton wavelength $\lambda_C \propto E_b^{-1/2}$, which for some of the observed cases can be as large as 10 fm in size. The prompt (pure QCD) experimental production rate of $X(3872)$ argues against the generation of such extended states [13]. Nevertheless, numerous papers have argued for the molecular picture (see Ref. [14] for many references and extensive discussion), e.g., as a mixture of the $\chi_{c1}(2P)$ and $(D^{*0}\bar{D}^0)$. Alternatively, the XYZ states could be *hadro-charmonium*, an ordinary charmonium state embedded in a light-quark cloud [15]; however, such states would presumably mix with conventional charmonium states with the same quantum numbers.

In this Letter, we have been inspired by a well-known hypothesis for the XYZ states—that of a diquark-antidiquark ($\delta\bar{\delta}$) pair, $[q_2q_4][\bar{q}_1\bar{q}_3]$ [16] (states formed from color $\mathbf{8}$ $[q\bar{q}]$ diquarks have also been considered [17,18]). The principal advantage of any diquark picture is its flexibility in incorporating QCD color physics not available in approaches in which the individual $\bar{q}q$ pairs are bound into color singlets before any other effects are

considered. This flexibility of the $\delta\bar{\delta}$ picture is also its chief drawback, because one must sort through many possible dynamical configurations in order to determine which ones capture the essential physics of the XYZ states. Moreover, the $\delta\bar{\delta}$ picture supports numerous hadronic states, due to the spin and flavor degrees of freedom of each quark; without some simplifying constraint on the allowed dynamics, the picture rapidly becomes unwieldy and loses predictivity. Nevertheless, at least one recent collaboration [19] finds that the charged $Z_c(4020)$ state emerges from lattice simulations only if diquark interpolating operators are included.

As a simple prototype of a $\delta\bar{\delta}$ state, consider a QED *tetralectron*, formed from $(\mu^+\mu^-e^+e^-)$. Such a state is not as exotic as it might first appear, since the dipositronium state $(e^+e^-)(e^+e^-)$ has actually been produced [20]. The strong internal Coulomb forces can be canceled by forming bound, neutral components in two ways, either as $(\mu^+\mu^-)(e^+e^-)$ (a “true muonium” [21]-positronium molecule) or $(\mu^+e^-)(e^+\mu^-)$ (a muonium-antimuonium molecule); then the strongest residual force between them is the coupling between their magnetic dipole moments, which in turn is strongest when each of the neutral components contains a lighter particle. Thus, one finds that the $(\mu^+e^-)(e^+\mu^-)$ pairing would be the most tightly bound; assuming the e^-e^+ annihilate first, the remnant $\mu^+\mu^-$ would then naturally form a true muonium atom, but at the larger characteristic size of ordinary muonium. For an even closer analogue to the QCD system, one can imagine a hypothetical μ^- with charge $-2|e|$. It would still combine as $(\mu^+e^-)(e^+\mu^-)$, but each component now has a net charge.

The case of QCD is, of course, more complicated. However, one may note that the qq pair can couple to only two irreducible color representations, $\mathbf{3} \otimes \mathbf{3} = \bar{\mathbf{3}} \oplus \mathbf{6}$ (cf. $\mathbf{3} \otimes \bar{\mathbf{3}} = \mathbf{1} \oplus \mathbf{8}$). The binding of qq or $\bar{q}q$ systems (call their component color representations $R_{1,2}$) depends only on the quadratic Casimir $C_2(R)$ of the product color representation R to which the quarks couple, according to $C_2(R) - C_2(R_1) - C_2(R_2)$. From this simple rule, one finds the relative size of the couplings for a quark-(anti)quark pair to be $\frac{1}{3}(-8, -4, +2, +1)$ for $R = (\mathbf{1}, \bar{\mathbf{3}}, \mathbf{6}, \mathbf{8})$, respectively; in particular, the $\mathbf{1}$ is the unique attractive color channel for $\bar{q}q$, and the $\bar{\mathbf{3}}$ is the unique attractive color channel for qq . It is thus natural to model the tetraquark as a bound color- $\bar{\mathbf{3}}$ diquark and a bound color- $\mathbf{3}$ antidiquark attracted by color-Coulomb forces; this is the picture implicitly assumed in Ref. [16].

If one adopts the further ansatz that the dominant nonuniversal interactions among the tetraquark components are spin-spin interactions within each diquark, one obtains a very reasonable explanation of the currently known XYZ states [22]. The primary limitation of this picture is the fact that the (charged) isospin partners of the neutral X , Y states have not yet been observed; for example, the $X(3872)$ in Ref. [22] has the structure

$1/\sqrt{2}([cq]_1[\bar{c}\bar{q}]_0 + [cq]_0[\bar{c}\bar{q}]_1)$, where q is a light quark and the subscript indicates the diquark spin. No obvious charged partners of the $X(3872)$ have been observed; however, in this case, one can argue that $\bar{q}q$ is really the $I = 0$ combination $1/\sqrt{2}(\bar{u}u - \bar{d}d)$, and that the corresponding $I = 1$ states are somewhat higher in mass. Furthermore, one can explain [23] its tiny width and its ability to decay into J/ψ and either ω ($I = 0$) or ρ ($I = 1$) by noting that the mass $m_{X(3872)}$ is slightly below $m_{J/\psi} + m_{\omega\text{peak}}$ but is very close to $m_{J/\psi} + m_{\rho\text{peak}}$; the former channel is preferred by isospin conservation (QCD) but suppressed by phase space, while the latter channel is favored by phase space but suppressed by isospin-violating (QED) ρ - ω mixing.

As mentioned above, the conventional charmonium states are well fit using solutions of a Schrödinger equation with a nonrelativistic potential $V(r)$. In the most thorough recent analysis [6], the potential is taken to be

$$V(r) = -\frac{4\alpha_s}{3r} + br + \frac{32\pi\alpha_s}{9m_c^2} \left(\frac{\sigma}{\sqrt{\pi}}\right)^3 e^{-\sigma^2 r^2} \mathbf{S}_c \cdot \mathbf{S}_{\bar{c}}, \quad (1)$$

where $\alpha_s = 0.5461$, $b = 0.1425$ GeV², $m_c = 1.4797$ GeV, and $\sigma = 1.0946$ GeV. The origin of the color $-4/3$ factor as the $\mathbf{3}\text{-}\bar{\mathbf{3}}$ coupling has already been noted. Since the first two terms in the potential $V(r)$ are determined solely by the nature of the color field, one may use the same potential to describe the interaction of the $\delta\bar{\delta}$ interaction. The third (spin-dependent) term does depend upon the sources being fermionic, but it is of short range, and its chief purpose is to accommodate 3S_1 - 1S_0 and 3P_J splittings. Should the $\delta\bar{\delta}$ potential require a $\mathbf{S}_{qq} \cdot \mathbf{S}_{\bar{q}\bar{q}}$ term, we note that it would still vanish for any state consisting solely of terms for which at least one of S_{qq} or $S_{\bar{q}\bar{q}}$ vanishes; this condition is believed to hold [22] for $X(3872)$, as well as for $Z(4430)^- = 1/\sqrt{2}([cd]_1[\bar{c}\bar{u}]_0 - [cd]_0[\bar{c}\bar{u}]_1)$.

Let us carry the notion of the binding of compact diquarks to its logical extreme, in which they can be considered as pointlike color-triplet sources bound in the potential given by Eq. (1). To compute their eigenvalues, one must input a value for the diquark mass m_{cq} . We prefer to use a determination that is independent of the nonrelativistic quark model, so we use the value computed using QCD sum rules [24]:

$$m_{cq} = 1.86 \pm 0.10 \text{ GeV}, \quad (2)$$

for both spin-0 and spin-1 diquarks. As long as $m_{cq} > m_c$, one finds that the wave function becomes more compact: $\langle r \rangle_{J/\psi} = 0.39$ fm $>$ $\langle r \rangle_{X_{1S}} = 0.31$ fm. However, this use of the Schrödinger equation now becomes suspect. If one believes each diquark to have a size like that of a D meson (say, ≈ 0.5 fm), it is difficult to justify treating them as pointlike compared to $\langle r \rangle$.

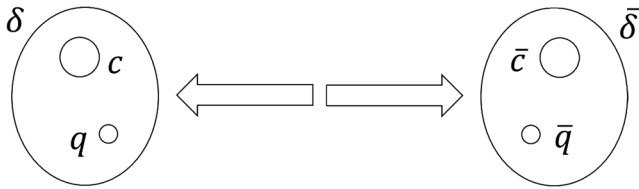

FIG. 1. Diquark-antidiquark production. The arrows indicate a color flux tube connecting the color- $\bar{3}$ diquark δ and the color- 3 antidiquark $\bar{\delta}$.

We come at last to the central idea of this Letter. We propose that the XYZ states are not conventional non-relativistic bound states in the sense of solutions of a Schrödinger equation for a static potential, but are instead collective modes of a $\delta\bar{\delta}$ pair produced at a high relative momentum (Fig. 1). Were it not for confinement, the diquarks would fly apart as compact, free (colored) mesons; instead, their large relative kinetic energy is gradually converted into potential energy of the color flux tube connecting them, an “open-string hadron” picture. Eventually they are brought relatively to rest after achieving a substantial separation (Fig. 2). We propose that this is the dynamical physics underlying the formation of exotic tetraquark states. The tetraquark has an observably narrow width because of its difficulty in hadronizing; if the $\delta\bar{\delta}$ pair were replaced by a $q\bar{q}$ pair (again, which has the same $\bar{3}-3$ color structure), the system would promptly fragment into two or more mesons upon the creation of an additional $q'\bar{q}'$ pair.

The corresponding scenario in the $\delta\bar{\delta}$ system would produce a baryon-antibaryon pair (Fig. 3); in fact, this

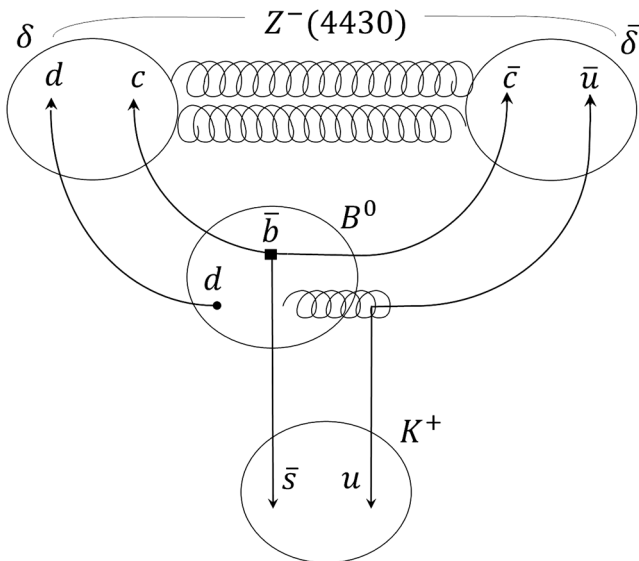

FIG. 2. Illustration of the production of a spatially extended diquark-antidiquark state $\delta\bar{\delta}$ attracted by long-range color forces (indicated by gluon lines). Here, the mechanism is illustrated for $B^0 \rightarrow Z(4430)^- K^+$, where the filled square indicates the \bar{b} -quark weak decay.

system has long been considered in the literature and is called *baryonium* [25]. Should this $\delta\bar{\delta}$ picture truly hold for the XYZ states, one would expect such a state with a dominant $\Lambda_c^+ \bar{\Lambda}_c^-$ decay mode (Λ_c^+ being the lightest charmed baryon) to appear very soon after the threshold at 4573 MeV is passed; indeed, as noted in Ref. [26], such a state has been observed, the $X(4632)$.

Ordinary fragmentation is not permitted below the $\Lambda_c^+ \bar{\Lambda}_c^-$ threshold, and another hadronization mechanism must occur. One mechanism that has been identified in older literature assumes that the quarks in δ meet their antiquark partners in $\bar{\delta}$ (to form mesons) through a tunneling process [27]; such a process would likely be very slow and leads to near-stable tetraquark mesons. However, we propose a much simpler and quicker fate for the $\delta\bar{\delta}$ states: Hadronization into charmonium and other mesons proceeds through the large- r tails of their wave functions stretching from the δ to the $\bar{\delta}$ (Fig. 4); the larger the $\delta\bar{\delta}$ separation, the more suppressed the overlap integrals; hence, a more highly suppressed amplitude, and ultimately, a smaller width.

Because the extended $\delta\bar{\delta}$ system contains a great deal of color energy, it hadronizes (albeit with a small width) almost as soon as a threshold for creating hadrons with the same quantum numbers is passed, and final states with the smallest number of particles should dominate. In the case of the $J^{PC} = 1^{++}$ $X(3872)$, the first such isospin-conserving threshold is $J/\psi + \omega$. The combination of the small $\langle J/\psi\omega | \delta\bar{\delta} \rangle$ overlaps, small phase space, and the role of isospin violation discussed above can conspire to give the $X(3872)$ its surprisingly small width. In this picture, one expects to find a $\delta\bar{\delta}$ resonance just beyond the threshold for the lowest charmonium-light meson threshold that has the same quantum numbers; for example, an isotriplet with $J^P = 1^+$ is expected not far above $m = m_{J/\psi} + m_{\rho^+} = 3872$ MeV or the $I = 1$ channel of $D\bar{D}^*$ (≈ 3876 MeV), and indeed, BESIII finds [3] a 1^+ state of mass $3883.9 \pm 1.5 \pm 4.2$ MeV [$Z_c(3885)$, which is believed to be the $Z(3900)$ coupled to the $D\bar{D}^*$ -meson modes]. The means by which a resonance can synchronize with a threshold (the so-called *cusp effect*) is discussed in Ref. [28], and interesting effects that occur when related channels couple near threshold is discussed in Ref. [29].

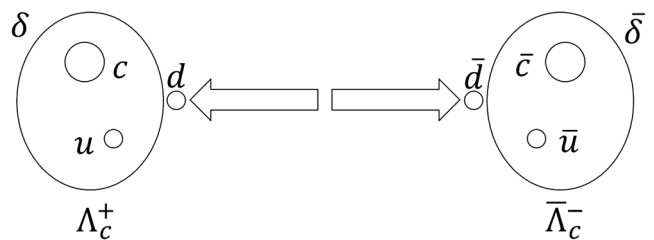

FIG. 3. The baryonium system: Fragmentation of the color flux tube connecting the diquark-antidiquark pair $\delta\bar{\delta}$ into the lowest-lying baryon-antibaryon state, $\Lambda_c^+ \bar{\Lambda}_c^-$.

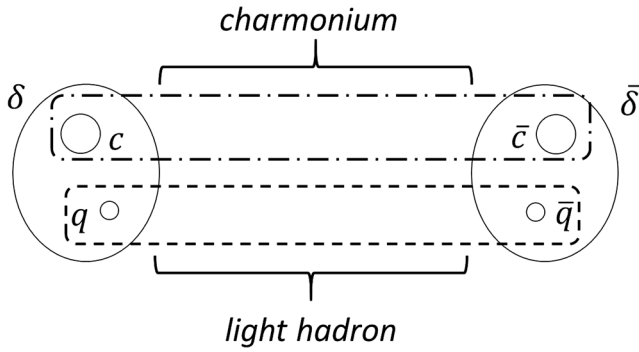

FIG. 4. Illustration of the mechanism that suppresses the hadronization rate of diquark-antidiquark ($\delta\bar{\delta}$) extended states, due to the small wave-function overlap (indicated by dashed lines) at large spatial separation.

However, not every XYZ state in this picture needs to lie near a threshold. In the diquark model of Ref. [22], multiplets arise from different orientations of the spins within δ and $\bar{\delta}$, as well as their combination to form the J^P of the full $\delta\bar{\delta}$ state. Once one state is formed from the appearance of a threshold, several others form as well. In addition, the color flux tube that connects the δ and $\bar{\delta}$ also can be excited; in Ref. [22] the $J^{PC} = 1^{--}Y$ states are identified as its orbital $L = 1$ excitations. Furthermore, the flux tube can have longitudinal excitations, which were identified in Ref. [22] as radial modes; in particular, the $Z(4430)$ is identified as the $2S$ partner to the $1S$ $Z(3900)$. This identification is made in part due to the strong preferential couplings of $Z(3900) \rightarrow J/\psi$ and $Z(4430) \rightarrow \psi(2S)$.

The preferential coupling of some of the XYZ states to the $\psi(2S)$ has been a longstanding mystery. After all, both J/ψ and $\psi(2S)$ are $J^P = 1^{--}$ states, and one naively expects any state that can decay to $\psi(2S)$ can also couple to the much lighter J/ψ . Let us now perform a simple calculation to show how our picture leads to a natural observed preference of $B^0 \rightarrow Z(4430)^- K^+ \rightarrow \psi(2S)\pi^- K^+$. Using as inputs m_{B^0} , m_{K^+} , and $m_{Z(4430)}$, transforming into the c.m. frame of the $\delta\bar{\delta}$ pair, and using m_{cq} from Eq. (2), one obtains the initial $\delta\bar{\delta}$ pair kinetic energy T_{cq} . Using Eq. (1) and its numerical inputs, all of the T_{cq} kinetic energy converts into potential energy at the large $\delta\bar{\delta}$ separation $r_Z = 1.16$ fm. In comparison, the corresponding value for the $X(3872)$ is $r_X = 0.56$ fm.

The natural figures of merit we use to compare the relative likelihood of $Z(4430) \rightarrow J/\psi + \pi$ and $Z(4430) \rightarrow \psi(2S) + \pi$ transitions are the ratios of probability densities of the $1S$ and $2S$ states evaluated at r_X and r_Z . Using Eq. (1), one finds the values $|\Psi_{1S}(r)/\Psi_{2S}(r)|_{r=r_X}^2 = 2.41 : 1$ and $|\Psi_{1S}(r)/\Psi_{2S}(r)|_{r=r_Z}^2 = 1 : 75.6$. The preference of the decay $Z(4430) \rightarrow \psi(2S) + \pi$ [and $Z(3900) \rightarrow J/\psi + \pi$] is thus very natural in this picture. Clearly, one may consider any suitable weighting functions about $r_{X,Z}$ and obtain comparable results. The anticipated preferential decay of

the tetraquark $\mu^+e^-\mu^-e^+$ to positronium plus a large-size $\mu^+\mu^-$ atom has a similar origin.

Why are tetraquark states obvious in the charm (and likely bottom [30]) sector but not in the light-quark sector? Again, we believe that our picture provides guidance, based on the energy scales of the tetraquark states. While the scalars $a_0(980)$ and $f_0(980)$ may also be $\delta\bar{\delta}$ states [31] (and indeed have been argued to be tetraquarks for a long time [32]; note also recent work [33,34] to measure their tetraquark content), it is not clear that their δ and $\bar{\delta}$ components are sufficiently compact that they do not overlap and instantly mix with a meson-meson configuration. In the case of decays with heavier quarks like charm, we have seen that the large energy release makes the $\delta\bar{\delta}$ separation sufficiently large to distinguish them.

This calculation is decidedly quite crude. We have used a classical turning point for the potential, which can be improved via the Wentzel-Kramers-Brillouin approximation. We have used one particular determination of the diquark mass (which in turn is treated as a compact quasiparticle), which of course can be varied. We have used the phenomenological nonrelativistic potential $V(r)$ of Eq. (1) to represent confinement physics and ignored that relativistic systems should be described in terms of helicities rather than spins; however, one may use instead a lattice-based determination, or the result of an AdS/QCD calculation which uses fully covariant front-form dynamics, and obtain comparable results [35].

In conclusion, we have presented a dynamical picture to explain the nature of the exotic XYZ states based on a diquark-antidiquark open-string configuration. Our model provides a natural explanation of why some, but not all, of the states lie very close to hadronic thresholds, and why some of the states prefer to decay to excited charmonium states. Although this picture is only semiquantitative, we believe it provides a good starting point for understanding the structure, formation, and decay of these exotica.

This work was supported by the U.S. Department of Energy under Grant No. DE-AC02-76SF00515 (S. J. B.); by the Korea Foundation for International Cooperation of Science & Technology (KICOS), and the Basic Science Research Programme through the National Research Foundation of Korea (2010-0011034) (D. S. H.); and by the National Science Foundation under Grant No. PHY-1068286 (R. F. L.). In addition, D. S. H. thanks H. Son for technical assistance, and R. F. L. thanks T. Cohen, L. Haibo, and T. Skwarnicki for enlightening exchanges.

*sjbth@slac.stanford.edu

†dshwang@sejong.ac.kr

‡richard.lebed@asu.edu

[1] S. K. Choi *et al.* (Belle Collaboration), *Phys. Rev. Lett.* **91**, 262001 (2003).

[2] N. Brambilla *et al.*, [arXiv:1404.3723](https://arxiv.org/abs/1404.3723).

- [3] C.-Z. Yuan, [arXiv:1404.7768](https://arxiv.org/abs/1404.7768).
- [4] E. Eichten, K. Gottfried, T. Kinoshita, K. D. Lane, and T.-M. Yan, *Phys. Rev. D* **17**, 3090 (1978); **21**, 313 (1980).
- [5] E. Eichten, K. Gottfried, T. Kinoshita, K. D. Lane, and T.-M. Yan, *Phys. Rev. D* **21**, 203 (1980).
- [6] T. Barnes, S. Godfrey, and E. S. Swanson, *Phys. Rev. D* **72**, 054026 (2005).
- [7] R. Aaij *et al.* (LHCb Collaboration), *Phys. Rev. Lett.* **112**, 222002 (2014).
- [8] S. Weinberg, *Phys. Rev. Lett.* **110**, 261601 (2013).
- [9] R. F. Lebed, *Phys. Rev. D* **88**, 057901 (2013).
- [10] T. D. Cohen and R. F. Lebed, *Phys. Rev. D* **89**, 054018 (2014).
- [11] T. D. Cohen and R. F. Lebed, *Phys. Rev. D* **90**, 016001 (2014).
- [12] S. J. Brodsky, I. A. Schmidt, and G. F. de Teramond, *Phys. Rev. Lett.* **64**, 1011 (1990).
- [13] C. Bignamini, B. Grinstein, F. Piccinini, A. D. Polosa, and C. Sabelli, *Phys. Rev. Lett.* **103**, 162001 (2009).
- [14] N. Brambilla *et al.*, *Eur. Phys. J. C* **71**, 1534 (2011).
- [15] M. B. Voloshin, *Prog. Part. Nucl. Phys.* **61**, 455 (2008).
- [16] L. Maiani, F. Piccinini, A. D. Polosa, and V. Riquer, *Phys. Rev. D* **71**, 014028 (2005).
- [17] H. Høgaasen, J.-M. Richard, and P. Sorba, *Phys. Rev. D* **73**, 054013 (2006).
- [18] F. Buccella, H. Høgaasen, J.-M. Richard, and P. Sorba, *Eur. Phys. J. C* **49**, 743 (2007).
- [19] S. Prelovsek, C. B. Lang, L. Leskovec, and D. Mohler, [arXiv:1405.7623](https://arxiv.org/abs/1405.7623) [*Phys. Rev. Lett.* (to be published)].
- [20] D. B. Cassidy and A. P. Mills, *Nature (London)* **449**, 195 (2007).
- [21] S. J. Brodsky and R. F. Lebed, *Phys. Rev. Lett.* **102**, 213401 (2009).
- [22] L. Maiani, F. Piccinini, A. D. Polosa, and V. Riquer, *Phys. Rev. D* **89**, 114010 (2014).
- [23] M. Karliner and H. J. Lipkin, [arXiv:1008.0203](https://arxiv.org/abs/1008.0203).
- [24] R. T. Kleiv, T. G. Steele, A. Zhang, and I. Blokland, *Phys. Rev. D* **87**, 125018 (2013).
- [25] G. C. Rossi and G. Veneziano, *Nucl. Phys.* **B123**, 507 (1977).
- [26] G. Cotugno, R. Faccini, A. D. Polosa, and C. Sabelli, *Phys. Rev. Lett.* **104**, 132005 (2010).
- [27] A. T. Aerts, P. J. Mulders, and J. J. De Swart, *Phys. Rev. D* **21**, 1370 (1980).
- [28] D. V. Bugg, *J. Phys. G* **35**, 075005 (2008).
- [29] M. B. Voloshin, [arXiv:hep-ph/0602233](https://arxiv.org/abs/hep-ph/0602233).
- [30] M. Karliner and S. Nussinov, *J. High Energy Phys.* **07** (2013) 153.
- [31] L. Maiani, F. Piccinini, A. D. Polosa, and V. Riquer, *Phys. Rev. Lett.* **93**, 212002 (2004).
- [32] R. L. Jaffe, *Phys. Rev. D* **15**, 267 (1977).
- [33] S. Stone and L. Zhang, *Phys. Rev. Lett.* **111**, 062001 (2013).
- [34] R. Aaij *et al.* (LHCb Collaboration), *Phys. Rev. D* **90**, 012003 (2014).
- [35] A. P. Trawiński, S. D. Głazek, S. J. Brodsky, G. F. de Teramond, and H. G. Dosch, [arXiv:1403.5651](https://arxiv.org/abs/1403.5651).