

Breakdown of the Cross-Kerr Scheme for Photon Counting

Bixuan Fan,¹ Anton F. Kockum,² Joshua Combes,³ Göran Johansson,² Io-chun Hoi,² C. M. Wilson,² Per Delsing,²
G. J. Milburn,^{1,†} and Thomas M. Stace^{1,*}

¹*Center for Engineered Quantum Systems, School of Mathematics and Physics, The University of Queensland,
St Lucia, Queensland 4072, Australia*

²*Microtechnology and Nanoscience, Chalmers University of Technology, S-41296 Göteborg, Sweden*

³*Center for Quantum Information and Control, University of New Mexico, Albuquerque, New Mexico 87131-0001, USA*

(Received 4 October 2012; published 30 January 2013)

We show, in the context of single-photon detection, that an atomic three-level model for a transmon in a transmission line does not support the predictions of the nonlinear polarizability model known as the cross-Kerr effect. We show that the induced displacement of a probe in the presence or absence of a single photon in the signal field, cannot be resolved above the quantum noise in the probe. This strongly suggests that cross-Kerr media are not suitable for photon counting or related single-photon applications. Our results are presented in the context of a transmon in a one-dimensional microwave waveguide, but the conclusions also apply to optical systems.

DOI: [10.1103/PhysRevLett.110.053601](https://doi.org/10.1103/PhysRevLett.110.053601)

PACS numbers: 42.50.Lc, 42.65.-k, 85.60.Gz

The cross-Kerr effect, whereby the phase of one field is changed proportional to the intensity of another, arises from the nonlinear response of an atomic medium to applied fields. It is usually described phenomenologically in terms of a third order term in the nonlinear polarizability, a description that is valid when the applied fields are strong and absorption is weak [1]. Microscopic derivations of the Kerr effect are discussed in Refs. [2–4].

Many proposed quantum applications of the cross-Kerr effect suppose that at least one of the fields is very weak—perhaps only a single photon—including nondemolition measurements [5–8], state preparation [9–13], teleportation [14], and logic gates buildup [15–19]. These schemes require strong Kerr nonlinearities at the single-photon level. It is not clear that the standard model of a cross-Kerr effect, based on a third-order nonlinear polarizability, should be valid for such weak fields.

Doubts regarding the utility of the Kerr effect in single-photon applications have been raised before. Shapiro and Razevi [20,21] considered the multimode nature of the single-photon pulse and found that there is extra phase noise compared to simple single mode calculations, leading to constraints on the achievable phase shifts. Gea-Banacloche [22] pointed out that it is impossible to obtain large phase shifts via the Kerr effect with single-photon wave packets. None of this prior work has addressed in detail the question of the cross-Kerr phase shift on a coherent probe field in the presence or absence of a single photon in the control field.

Recently, superconducting circuits have become important test beds for microwave quantum optics, demonstrating quantized fields, artificial “atoms” (i.e., with well-resolved energy levels), and strong “atom”-field interactions [23–25]. The transmon [26] is a promising superconducting artificial atom due to its insensitivity to $1/f$ noise, strong anharmonicity, and large dipole moment.

Indeed, the typical size of a transmon is comparable to the dielectric gap in an on-chip microwave waveguide, and so the dipole moment is within an order of magnitude of the maximum that it can possibly be, given the geometrical constraints of the dielectric gap [27]. This fact leads to very large cross-Kerr nonlinearities, where the transmon provides the nonlinear polarizability. Recent experiments using a superconducting transmon in a 1D microwave transmission line have demonstrated gigantic cross-Kerr nonlinearities: a control field with *on average* one photon induces a phase shift in the probe field of 11 degrees [28]. Importantly, in this experiment, the microwave fields were freely propagating; no cavity was involved.

This large cross-Kerr phase shift immediately suggests the possibility of constructing a broadband, number-resolving, microwave-photon counter, as long as the cross-Kerr induced displacement of the probe exceeds the intrinsic quantum noise in the probe. Indeed, broadband microwave photon counting is a crucial missing piece of the experimental quantum microwave toolbox, although there are several proposals for detecting microwave photons [29–33].

In fact, the cross-Kerr interaction is strictly an effective interaction based on weak field-dipole coupling approximations. Ultimately it is mediated by the strong nonlinearities inherent in an anharmonic oscillator (e.g., an atom), so it must eventually break down. The microscopic dynamics become important in the limit of very strong coupling, which was achieved in Ref. [28]. In this work we investigate the coupled field-transmon dynamics in this limit, using proposals for microwave-photon counting as a technical objective to evaluate the validity of the cross-Kerr approximation.

We consider two fields, a probe and a control, incident on a transmon, which is treated as a three-level, Ξ -type

system in a one-dimensional transmission line. Such three-level systems are prototypes for analyzing cross-Kerr nonlinearities [6]. We treat the transmon dynamics exactly, including quantum noise in the incident fields. The probe is assumed to be a coherent field (or possibly squeezed), while the control field is in a Fock state, whose photon number, n , we are trying to measure. For our purposes, we restrict to $n = 0$ or 1.

We show that in spite of the very large cross-Kerr nonlinearity, the induced probe displacement (i.e., the signal) in the presence of a single control photon is limited by saturation of the transmon, and is always less than the probe's own quantum noise. That is, the signal-to-noise ratio (SNR) is always below unity. Moreover, our conclusion also extends to the N-type four-level atomic level configuration, with which cross-Kerr media are often modeled [34–37]. These conclusions have profound implications for the quantum applications of cross-Kerr phenomena.

The transmon levels are $\{|a\rangle, |b\rangle, |c\rangle\}$, with corresponding energy levels, ω_i , and decay rates, γ_i , as shown in Fig. 1. Relaxation between transmon energy levels is fast compared to dephasing rates, which we neglect. The probe field, \hat{b} , is in a coherent state $|\beta\rangle$, and is nearly resonant with the $|b\rangle \leftrightarrow |c\rangle$ transition, while the control field is in a Fock state of $n = 0$ or 1 photons, at a frequency ω_{con} close to the $|a\rangle \leftrightarrow |b\rangle$ transition. Qualitatively, the control field induces a transient population transfer into the state $|b\rangle$, and the probe field induces transmon polarization, σ_{bc} , between states $|b\rangle$ and $|c\rangle$. This polarization couples back to the probe field, so that the probe field is modified from its input state according to the standard input-output relation

$$\hat{b}_{\text{out}} = \hat{b}_{\text{in}} + \sqrt{\gamma_c} \hat{\sigma}_{bc}, \quad (1)$$

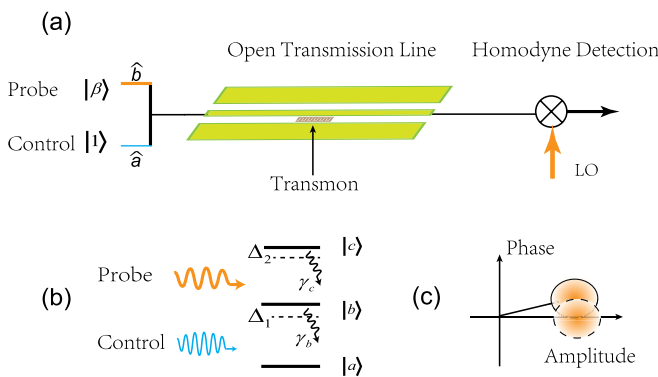

FIG. 1 (color online). (a) Illustrative experimental arrangement. A photon source emits a Fock state microwave photon into a 1D planar transmission line with a Ξ -type three-level transmon embedded in it. (b) Transmon level structure. The coherent probe couples $|b\rangle \leftrightarrow |c\rangle$, and the control couples $|a\rangle \leftrightarrow |b\rangle$. The interaction induced phase shift in the probe field is detected by homodyne detection. (c) Cartoon of the Kerr-induced probe displacement.

where \hat{b} is the annihilation operator of the probe field. The homodyne detector monitoring the output probe field yields a photocurrent given by

$$J_n^{\text{hom}}(t) = \langle \hat{y}(t) \rangle + \xi(t), \quad (2)$$

where $\hat{y} = -i\sqrt{\gamma_c}(\hat{\sigma}_{bc} - \hat{\sigma}_{cb})$ is the transmon polarization, $\hat{\sigma}_{ij} = |i\rangle\langle j|$, and $\xi dt = dW(t)$ is a Weiner process satisfying $E[dW] = 0$, $E[d^2W] = dt$. Here $E[X]$ represents the classical expectation value of the variable X . Finally, the useful signal is the weighted integral of the homodyne current over the lifetime, T , of the photon wave packet

$$S_n = \int_0^\infty dt J_n^{\text{hom}}(t) w(t) \quad (3)$$

where $w(t)$ is a weight function. To be more specific, we choose $f(t)$ to be the “top-hat” function, $w(t) = 1$ for $0 < t < T$, $w(t) = 0$ otherwise. If $n = 0$ the transmon dynamics are trivial, and $E[S_0] = 0$. For $n = 1$, $E[S_1] \neq 0$, and so S_1 represents the useful signal associated with a single photon in the control field. However, in any given measurement, the homodyne current includes quantum noise, characterized by the variance $(\sigma_{S_n})^2 = E[S_n^2] - E[S_n]^2$. To a good approximation, σ_{S_n} is independent of the photon number, n , so we define the signal-to-noise ratio, $\text{SNR} = E[S_1]/(\sqrt{2}\sigma_S)$. Note that we assume that the homodyne current will also include technical noise sources. We ignore these, so that the SNR represents the quantum limit for this scheme.

To study quantitatively the system consisting of a transmon interacting with propagating microwave fields, we adopt two different (but consistent) formulations, yielding both numerical and analytic results.

In the first formulation we suppose the control photon is generated by a fictitious cavity which is initially in a Fock state. The field in the cavity decays into the 1D waveguide, and propagates to the transmon, which mediates the interaction between the control and the probe [38]. To analyze this system, we employ a stochastic cascaded master equation (SME) [39,40]. The SME describing the conditional dynamics of the cascaded cavity field-transmon density matrix, ρ , is given by

$$\begin{aligned} d\rho = & (-i[H_s, \rho] + \gamma_{\text{con}} \mathcal{D}[\hat{a}_{\text{con}}] \rho + \mathcal{D}[\hat{L}_b] \rho \\ & + \mathcal{D}[\hat{L}_c] \rho) dt + \sqrt{\gamma_{\text{con}}} ([\hat{L}_b, \rho \hat{a}_{\text{con}}^\dagger] \\ & + [\hat{a}_{\text{con}} \rho, \hat{L}_b^\dagger]) dt + \mathcal{H}[\hat{L}_c e^{-i\pi/2}] \rho dW \end{aligned} \quad (4)$$

where $\hat{L}_b = \sqrt{\gamma_b} \hat{\sigma}_{ab}$, $\hat{L}_c = \sqrt{\gamma_c} \hat{\sigma}_{bc}$ and

$$H_s = \Delta_c \hat{\sigma}_{cc} + \Delta_b \hat{\sigma}_{bb} + \Omega_p (\hat{\sigma}_{bc} + \hat{\sigma}_{cb}),$$

$$\mathcal{D}[\hat{r}] \rho = \frac{1}{2} (2\hat{r} \rho \hat{r}^\dagger - \rho \hat{r}^\dagger \hat{r} - \hat{r}^\dagger \hat{r} \rho),$$

$$\mathcal{H}[\hat{r}] \rho = \hat{r} \rho + \rho \hat{r}^\dagger - \text{Tr}[\hat{r} \rho + \rho \hat{r}^\dagger] \rho,$$

$\Delta_b = \omega_{ba} - \omega_{\text{con}}$, $\Delta_c = \Delta_p + \Delta_b$ ($\Delta_p = \omega_{bc} - \omega_p$)
 $\Omega_p = \sqrt{\gamma_{\text{con}}} \beta$, β is the amplitude of the coherent probe

field, \hat{a}_{con} ($\hat{a}_{\text{con}}^\dagger$) are the annihilation (creation) operators for the control field, and γ_{con} is the control photon linewidth. Line 2 of Eq. (4) describes the unidirectional evolution between the photon source and the transmon. We solve Eq. (4) for the conditional state of the field-transmon system, from which we compute the conditional homodyne photocurrent, using Eq. (2). This approach allows us to generate a simulated measurement record for ensembles of events in which $n = 0$ or 1, from which we obtain a histogram of homodyne currents to estimate the SNR.

The second formulation uses the Fock state master equation (FME) [41,42], in which the propagating photon wave packet drives the transmon directly [43]. The transmon density matrix, $\rho_{m,n}$, acquires indices representing coherences between the transmon and photon Fock subspaces m and n . The FME is then

$$\begin{aligned} \dot{\rho}_{m,n}(t) = & -i[H_s, \rho_{m,n}] + \mathcal{D}[\hat{L}_b]\rho_{m,n} + \mathcal{D}[\hat{L}_c]\rho_{m,n} \\ & + \sqrt{n}f^*(t)[\hat{L}_b, \rho_{m,n-1}] + \sqrt{m}f(t)[\rho_{m-1,n}, \hat{L}_b^\dagger] \end{aligned} \quad (5)$$

where $f(t)$ is a complex valued probability amplitude that determines the photon counting rate, $|f(t)|^2$. We first solve the dynamics for $\rho_{0,0}(t)$, which drives $\rho_{0,1}(t)$ and $\rho_{1,0}(t)$, which in turn drives $\rho_{1,1}(t)$. Then, using the quantum regression theorem [44], we calculate the SNR analytically [45], part A.

If the photon is derived from exponential (E) decay of a cavity mode, then $f(t) = \sqrt{\gamma_{\text{con}}}\exp(-\gamma_{\text{con}}t/2)$. Further, this method can handle arbitrary photon wave packets, and we include Gaussian (G) and rectangular (R), shown in Fig. 2(top), where $T = 1/\gamma_{\text{con}}$ is the pulse's temporal width. The photon induces a polarization, $\langle \hat{y}(t) \rangle$, in the transmon, shown in Fig. 2(bottom). Different pulse shapes yield modest differences in $\langle \hat{y}(t) \rangle$.

Figure 3 shows the SNR as a function of the probe amplitude with detunings and γ_{con} optimized. The points represent 5000 trajectories of the SME, while the solid line is computed from the FME, showing good agreement. The inset shows histograms of stochastic calculations of the integrated homodyne current with $n = 0$ and $n = 1$ (using parameters that optimize the SNR). Figure 4 shows the SNR versus the detunings Δ_b and Δ_c . Clearly, the optimal SNR is located at $\Delta_b = \Delta_c = 0$. We also numerically investigated the effect of varying the ratio γ_c/γ_b and for $1 < \gamma_c/\gamma_b < 100$ found that the SNR changes little from the value for the transmon $\gamma_c/\gamma_b = 2$, and remains less than unity [45]. Regardless of parameter settings the SNR is less than unity, so we conclude it is impossible to reliably distinguish between $n = 0$ and 1 in a single shot. This is borne out by the large overlap of the histograms.

We can understand the fact that $\text{SNR} < 1$ in the following way: a single control photon induces a variation in the transmon polarization \hat{y} , which manifests as a fluctuation in the homodyne current according to Eq. (2). However the

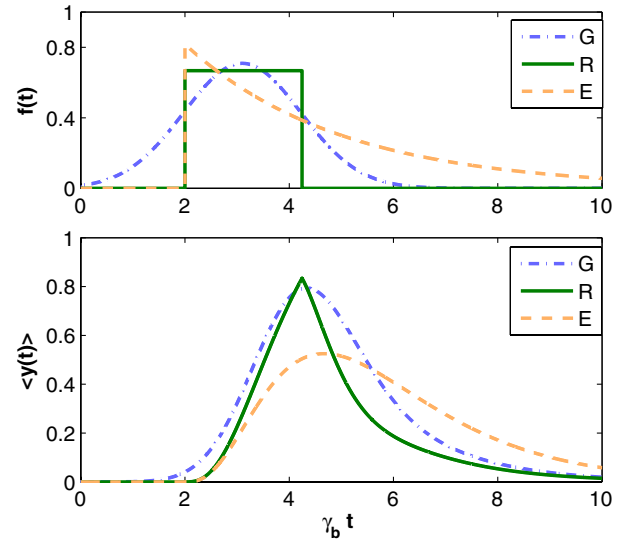

FIG. 2 (color online). The transmon responses for different control field wave packets. (top) Blue dot-dashed curve, Gaussian pulse (G); green solid curve, rectangular pulse (R); orange dashed curve, exponentially-decayed pulse (E); and (bottom) the corresponding polarization response of the transmon. The parameters are $\Delta_c = \Delta_b = 0$, $\gamma_{\text{con}} = 0.6672\gamma_b$, $\gamma_c = 2\gamma_b$, $\beta = 0.4\gamma_b$ (E); $0.47\gamma_b$ (R); $0.59\gamma_b$ (G).

polarization of the transmon is a bounded operator: $\|\hat{y}\| \leq \sqrt{\gamma_b}$. The optimal photon wave packet width is $T \sim \gamma_b^{-1}$ (any shorter and the transmon cannot respond to the field; any longer and vacuum noise in the homodyne signal

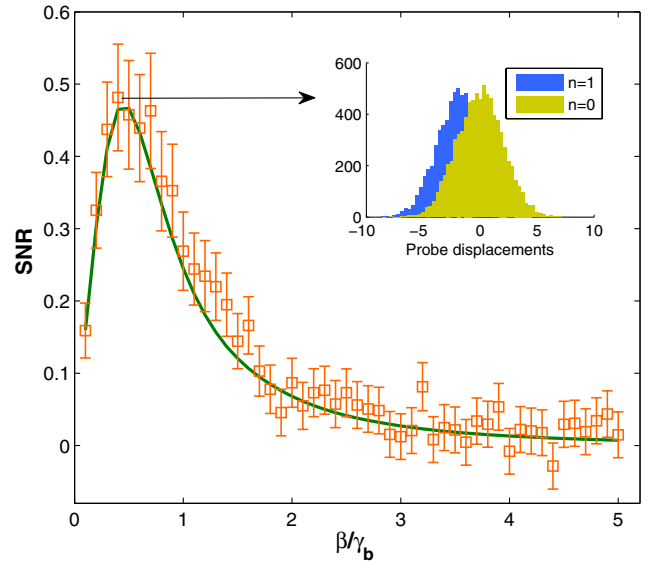

FIG. 3 (color online). The SNR as a function of the probe amplitude β at optimal parameter setting. The orange square represents the numerical SNR from the SME and the green curve represents the analytical SNR from the FME. The inset is a histogram of measurement outcomes, with parameters chosen to maximize the SNR.

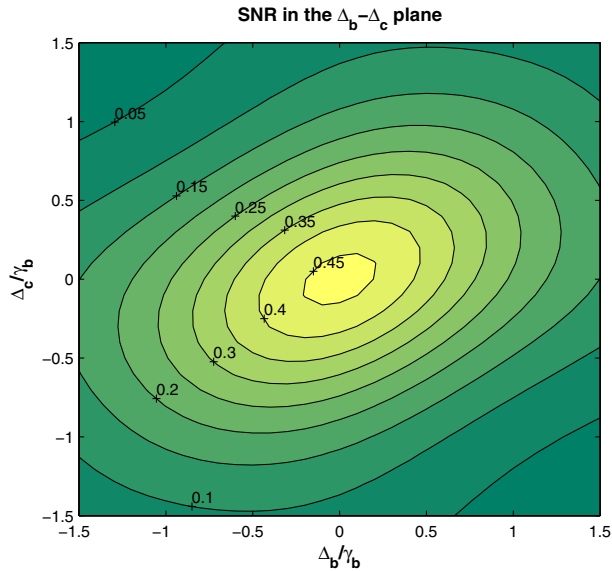

FIG. 4 (color online). The SNR of the probe field as functions of detunings Δ_b and Δ_c . The other parameters are: $\gamma_c = 2\gamma_b$, $\gamma_{\text{con}} = 0.6772\gamma_b$, $\beta = 0.4\gamma_b$.

grows), so the expected signal is bounded by $|E[S_1]| \leq \int_0^T dt |\hat{y}| \leq \gamma_b^{-1/2}$. Quantum noise in Eq. (2) gives $\sigma_S^2 \geq \text{var}[\int_0^T dt \xi] = \gamma_b^{-1}$ so we see that $\text{SNR} = |E[S_1]|/\sigma_S \leq 1$. Figure 3 bears out this analysis: for small probe field amplitudes, the SNR increases, however the transmon dynamics eventually saturates at large amplitudes.

This argument suggests that the fundamental problem is the saturation of the transmon transition. It may be thought that this can be addressed by increasing the number of transmons. We therefore briefly consider a system of N transmons, arranged such that the spacing between adjacent transmons is much smaller than the wavelength, the transmons are described by the collective atomic spin operators

$$\hat{S}_{ij} = \frac{1}{\sqrt{N}} \sum_k \sigma_{ij}^k. \quad (6)$$

The stochastic master equation describing the n -transmon system is given by

$$\begin{aligned} d\rho = & -i[H_s, \rho]dt + \gamma_{\text{con}} \mathcal{D}[\hat{a}_{\text{con}}]\rho dt + N\gamma_b \mathcal{D}[\hat{S}_{ab}]\rho dt \\ & + N\gamma_c \mathcal{D}[\hat{S}_{bc}]\rho dt - \sqrt{N\gamma_{\text{con}}\gamma_b}([\hat{S}_{ba}, \hat{a}_c\rho] \\ & + [\rho\hat{a}_c^\dagger, \hat{S}_{ab}])dt + \sqrt{N\gamma_c} \mathcal{H}[\hat{S}_{bc}e^{-i\pi/2}]\rho dW \end{aligned} \quad (7)$$

where

$$H_s = N(\Delta_c \hat{S}_{cc} + \Delta_b \hat{S}_b) + \sqrt{N\gamma_c}\beta(\hat{S}_{bc} + \hat{S}_{cb}). \quad (8)$$

We can see that the ensemble master equation (7) is the same form as the single-transmon master equation, albeit with decay rates and energies scaled by an N -dependent factor, leading to faster dynamics. This merely rescales the

parameters in the problem, so this cannot increase the SNR above the optimized single transmon case.

It is worth commenting on a number of other avenues that we have explored, but which yield similar negative results (for details, see the Supplemental Material [45]).

First, squeezing the probe field in an appropriate quadrature reduces the homodyne noise, and may improve the SNR. Since we are monitoring the phase displacement of the probe field, we should squeeze in this quadrature. However this enhances noise in the conjugate, amplitude quadrature. The additional noise in the probe amplitude adds noise to the transmon dynamics arising from fluctuations in Ω_p , which ultimately feed through to the output field. We find numerically that these tradeoffs yield no net improvement in the SNR [45].

Second, if the control photon interacts sequentially with M transmons in series, each with independent probes, the overall SNR would be increased by a factor of $M^{1/2}$. However, the Kramers-Kronig relations require that a large phase shift implies a large reflection probability, so that there is a tradeoff between the phase shift versus reflection probability at each transmon. Again, we find numerically that the tradeoff yields no net improvement in SNR [45].

Third, some schemes for inducing cross-Kerr nonlinearities in optical systems use an N-type four-level system [34,35], with a strong classical field addressing the intermediate transition. In the limit of strong driving, this maps onto the same three-level structure we consider in this Letter, so the conclusions we have reached here also apply to such N-type systems [45].

A number of proposals suggest using weak Kerr media to build controlled phase and controlled-NOT gates with fewer resources than linear optical schemes [17,19]. In these schemes the cross-Kerr phase shift per photon is much less than π , so a strong coherent bus compensates for the weak nonlinearity, such that the small cross-Kerr phase shift manifests as a large displacement of the strong coherent field. However the saturation of the cross-Kerr effect described above indicates that once the displacement of the strong coherent field approaches its own quantum noise, saturation effects lead to the breakdown of the effective cross-Kerr description, rendering such protocols ineffective.

In summary, we have investigated the feasibility of microwave photon counting based on an induced cross-Kerr nonlinearity arising from coupling to a large anharmonic dipole. We find that saturation of the transmon transition limits the SNR to less than unity. As such, it is not possible to use strong, atom-induced cross-Kerr nonlinearities to perform single-photon detection. This conclusion applies to a number of extensions of the basic model, including multiple transmons, cascaded transmons, and an N-type, four-level system. Further, it limits the applicability of any proposal that requires a cross-Kerr nonlinearity to produce a displacement of a coherent field

by an amount greater than the intrinsic quantum noise in the coherent field: it is precisely in this condition where the effective cross-Kerr description breaks down, and saturation effects become dominant.

This work is funded by the ARC Center of Excellence for Engineered Quantum Systems and China Scholarship Council. B.F. thanks Dr. Zhenglu Duan and Dr. Matt Woolley for helpful discussions. P.D., C.W., G.J., and I.H. acknowledge support from the Swedish Research Council and the EU through the ERC and the projects PROMISCE and SOLID. J.C. is supported by NSF Grants No. PHY-0903953, No. PHY-1212445, and No. PHY-1005540 and by ONR Grant No. N00014-11-1-0082.

*Corresponding author.

stace@physics.uq.edu.au

†Corresponding author.

milburn@physics.uq.edu.au

- [1] R. Boyd, *Nonlinear Optics* (Academic Press, New York, 2003).
- [2] P.D. Drummond and D.F. Walls, *Phys. Rev. A* **23**, 2563 (1981).
- [3] L. Hilico, C. Fabre, S. Reynaud, and E. Giacobino, *Phys. Rev. A* **46**, 4397 (1992).
- [4] G.F. Sinclair and N. Korolkova, *Phys. Rev. A* **77**, 033843 (2008).
- [5] N. Imoto, H. Haus, and Y. Yamamoto, *Phys. Rev. A* **32**, 2287 (1985).
- [6] P. Grangier, J.A. Levenson, and J.-P. Poizat, *Nature (London)* **396**, 537 (1998).
- [7] W.J. Munro, K. Nemoto, R. Beausoleil, and T. Spiller, *Phys. Rev. A* **71**, 033819 (2005).
- [8] C.F. Roos, T. Monz, K. Kim, M. Riebe, H. Häffner, D. James, and R. Blatt, *Phys. Rev. A* **77**, 040302(R) (2008).
- [9] M. Paternostro, M. Kim, and B. Ham, *Phys. Rev. A* **67**, 023811 (2003).
- [10] C.C. Gerry and A. Benmoussa, *Phys. Rev. A* **73**, 063817 (2006).
- [11] G.S. Jin, Y. Lin, and B. Wu, *Phys. Rev. A* **75**, 054302 (2007).
- [12] R.S. Said M.R.B. Wahiddin, and B.A. Umarov, *J. Phys. B* **39**, 1269 (2006).
- [13] T.V. Gevorgyan, A. Shahinyan, and G. Kryuchkyan, *Phys. Rev. A* **85**, 053802 (2012).
- [14] D. Vitali, M. Fortunato, and P. Tombesi, *Phys. Rev. Lett.* **85**, 445 (2000).
- [15] G.J. Milburn, *Phys. Rev. Lett.* **62**, 2124 (1989).
- [16] I.L. Chuang and Y. Yamamoto, *Phys. Rev. A* **52**, 3489 (1995).
- [17] K. Nemoto and W.J. Munro, *Phys. Rev. Lett.* **93**, 250502 (2004).
- [18] W.J. Munro, K. Nemoto, T.P. Spiller, S.D. Barrett, P. Kok, and R.G. Beausoleil, *J. Opt. B* **7**, S135 (2005).
- [19] W.J. Munro, K. Nemoto, and T.P. Spiller, *New J. Phys.* **7**, 137 (2005).
- [20] J.H. Shapiro, *Phys. Rev. A* **73**, 062305 (2006).
- [21] J.H. Shapiro and M. Razavi, *New J. Phys.* **9**, 16 (2007).
- [22] J. Gea-Banacloche, *Phys. Rev. A* **81**, 043823 (2010).
- [23] O. Astafiev, A.M. Zagoskin, A.A. Abdumalikov, Yu. A. Pashkin, T. Yamamoto, K. Inomata, Y. Nakamura, and J.S. Tsai, *Science* **327**, 840 (2010).
- [24] I.C. Hoi, C. Wilson, G. Johansson, T. Palomaki, B. Peropadre, and P. Delsing, *Phys. Rev. Lett.* **107**, 073601 (2011).
- [25] I.C. Hoi, T. Palomaki, J. Lindkvist, G. Johansson, P. Delsing, and C. Wilson, *Phys. Rev. Lett.* **108**, 263601 (2012).
- [26] J. Koch, T. Yu, J. Gambetta, A. Houck, D. Schuster, J. Majer, A. Blais, M. Devoret, S. Girvin, and R. Schoelkopf, *Phys. Rev. A* **76**, 042319 (2007).
- [27] M. Devoret, S. Girvin, and R. Schoelkopf, *Ann. Phys. (Berlin)* **16**, 767 (2007).
- [28] I.C. Hoi *et al.*, [arXiv:1207.1203](https://arxiv.org/abs/1207.1203).
- [29] G. Romero, J. García-Ripoll, and E. Solano, *Phys. Rev. Lett.* **102**, 173602 (2009).
- [30] G. Romero, J.J. García-Ripoll, and E. Solano, *Phys. Scr.* **T137**, 014004 (2009).
- [31] B. Johnson *et al.*, *Nat. Phys.* **6**, 663 (2010).
- [32] B. Peropadre, G. Romero, G. Johansson, C. Wilson, E. Solano, and J. García-Ripoll, *Phys. Rev. A* **84**, 063834 (2011).
- [33] Y.F. Chen, D. Hover, S. Sendelbach, L. Maurer, S. Merkel, and E. Pritchett, *Phys. Rev. Lett.* **107**, 217401 (2011).
- [34] H. Schmidt and A. Imamoglu, *Opt. Lett.* **81**, 3611 (1998).
- [35] H. Kang and Y. Zhu, *Phys. Rev. Lett.* **91**, 093601 (2003).
- [36] Y.F. Chen, C.-Yi. Wang, S.-H. Wang, and I. Yu, *Phys. Rev. Lett.* **96**, 043603 (2006).
- [37] Y. Hu, G.-Q. Ge, S. Chen, X.-F. Yang, and Y.-L. Chen, *Phys. Rev. A* **84**, 012329 (2011).
- [38] We emphasize that the cavity is included simply as a model photon source; the transmon outside the cavity.
- [39] C.W. Gardiner and P. Zoller, *Quantum Noise* (Springer, New York, 2004).
- [40] H. Wiseman and G. Milburn, *Quantum Measurement and Control* (Cambridge University Press, Cambridge, England, 2011).
- [41] B.Q. Baragiola, R. Cook, A. Brańczyk, and J. Combes, *Phys. Rev. A* **86**, 013811 (2012).
- [42] K. Gheri, K. Ellinger, T. Pellizzari, and P. Zoller, *Fortschr. Phys.* **46**, 401 (1998).
- [43] That is no photon source is invoked.
- [44] M. Lax, *Phys. Rev.* **129**, 2342 (1963).
- [45] See Supplemental Material at <http://link.aps.org/supplemental/10.1103/PhysRevLett.110.053601>: part A, for analytical solution for a three-level system on resonance; part B, for the effect of different relaxation rate ratio γ_c/γ_b ; part C, for squeezed probe case; part D, for cascaded multi-transmon case; and part E, for conversion from N-type Four-level structure to ladder-type three-level structure.