

## Coherent Control of Single-Photon Absorption and Reemission in a Two-Level Atomic Ensemble

Shanchao Zhang,<sup>1</sup> Chang Liu,<sup>1</sup> Shuyu Zhou,<sup>1</sup> Chih-Sung Chuu,<sup>2</sup> M. M. T. Loy,<sup>1</sup> and Shengwang Du<sup>1,\*</sup>

<sup>1</sup>*Department of Physics, The Hong Kong University of Science and Technology,  
Clear Water Bay, Kowloon, Hong Kong, People's Republic of China*

<sup>2</sup>*Physics Department, National Tsing Hua University, Hsinchu 30013, Taiwan, Republic of China*  
(Received 7 August 2012; published 27 December 2012)

We demonstrate coherent control of single-photon absorption and reemission in a two-level cold atomic ensemble. This is achieved by interfering the incident single-photon wave packet with the emission (or scattering) wave. For a photon with an exponential growth waveform with a time constant equal to the excited-state lifetime, we observe that the single-photon emission probability during the absorption can be suppressed due to the perfect destructive interference. After the incident photon waveform is switched off, the absorbed photon is then reemitted to the same spatial mode as that of the incident photon with an efficiency of 20%. For a photon with an exponential decay waveform with the same time constant, both the absorption and reemission occur within the waveform duration. Our experimental results suggest that the absorption and emission of a single photon in a two-level atomic ensemble may possibly be manipulated by shaping its waveform in the time domain.

DOI: [10.1103/PhysRevLett.109.263601](https://doi.org/10.1103/PhysRevLett.109.263601)

PACS numbers: 42.50.Nn, 03.65.Ta, 32.80.Qk, 42.50.Ct

Photon absorption and emission are two key probes to study the light-matter quantum interaction, which lays down the foundations for atomic, molecular, and optical physics [1–3]. When a coherent optical pulse propagates through a medium, the absorption and emission can coherently modify its spectral components and lead to many interesting and important optical phenomena, such as attenuation, amplification, distortion, and slow and fast light effects [4–8]. For a single photon, causality requires that the absorption and reemission follow the right time order: the reemission can only occur following the absorption. Although this quantum time order has been observed as the antibunching effect in resonance fluorescence measured by two-photon correlations [9,10], it is not controllable on demand in these experiments. When a single photon enters a two-level atomic medium, the absorption and emission usually both occur within the photon pulse duration. Recently, Scully *et al.* proposed a scheme for observing directed “spontaneous” emission excited by a single photon [11].

In this Letter, we demonstrate coherent control of single-photon absorption and reemission in a two-level cold atomic ensemble in free space by shaping the single-photon waveform. Making use of the destructive interference between the emission (or scattering) and the incident photon wave packet, we show that the probability of reemitting the photon during the absorption can be completely suppressed when the incident photon has an exponential growth waveform with a time constant equal to the excited-state lifetime. The reemission process only starts after the incident photon waveform is switched off and thus can be controlled on demand. This technique can be used to efficiently excite atoms with a given single atom. Our result may have potential applications in the quantum

networks that require efficient conversion between flying single-photon states and local atomic states [12].

Figure 1 illustrates the schematics of our modeled system. A single photon with an initial (single mode) wave packet  $\psi_{in}$  passes through a two-level atomic ensemble with atom density  $N$  and length  $L$ .  $|g\rangle$  and  $|e\rangle$  are the ground and excited states, respectively. Inside the atomic medium, this single photon with resonance frequency can be absorbed and reemitted. The elastically scattered (or reemitted) wave packet is denoted as  $\psi_s$ . A detector is placed far away to measure single-photon count along the incident direction.

We describe our theory in the Heisenberg picture where the single-mode single-photon wave packet can be expressed as  $\psi_{in}(t) = \langle 0|\hat{E}(t)|\Psi\rangle$ . Here,  $|0\rangle$  and  $|\Psi\rangle$  are the vacuum and single-photon states, respectively.  $\hat{E}(t)$  is the electric field operator. In this work, we are interested in the case where the single-photon scattering (into the same spatial mode as that of the incident photon) is completely suppressed by interfering with the incident wave packet. In this situation, the probability of finding an

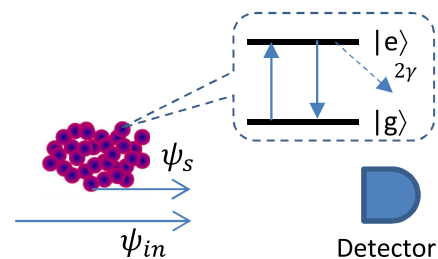

FIG. 1 (color online). A single photon propagates through a two-level atomic ensemble.  $\psi_{in}$  and  $\psi_s$  denote the incident and elastically scattered single-photon wave packets.

excited atom accumulates over time (due to the absorption), and thus the amplitude of stimulated electric dipole (operator) is proportional to the time integral of the photon waveform. In order to match their ( $\psi_{\text{in}}$  and  $\psi_s$ ) amplitudes for a complete destructive interference, it is required that the incident photon takes an exponential growth waveform. A number of theoretical papers have suggested that a single photon with the exponential growth waveform, which has a time constant equal to the excited-state lifetime, can be maximally absorbed and interacted with a single atom [13–17]. Following this, we take the incident single-photon field operator as

$$\hat{E}_{\text{in}}(t) = 2\sqrt{\frac{\hbar\omega\gamma}{c\varepsilon_0 A}} e^{\gamma t} \hat{a}_0 \theta(-t), \quad (1)$$

where  $\omega$  is the angular frequency of the photon that is on resonance to the two-level transition,  $c$  is the speed of light in vacuum,  $\varepsilon_0$  is the vacuum dielectric constant,  $A$  is the single-mode area, and  $\gamma$  is half of the population decay rate of the excited state  $|e\rangle$ .  $\hat{a}_0$  is the annihilation operator and satisfies  $[\hat{a}_0, \hat{a}_0^\dagger] = 1$ .  $\theta(-t)$  is the Heaviside function. As  $t < 0$ , the atomic operator  $\hat{\sigma}_{ge}$  driven by the external field follows

$$\frac{\partial}{\partial t} \hat{\sigma}_{ge} = -\gamma \hat{\sigma}_{ge} + \frac{i}{2} \frac{\mu}{\hbar} \hat{E}_{\text{in}}(t) (\hat{\sigma}_{gg} - \hat{\sigma}_{ee}), \quad (2)$$

where  $\mu$  is the electric dipole matrix element. We work at the weak-coupling regime for a single atom, and the mode area  $A$  is sufficiently large so that the atoms most likely remain in the ground state. Under such a ground-state approximation ( $\hat{\sigma}_{gg} - \hat{\sigma}_{ee} \approx 1$ ), we obtain  $\hat{\sigma}_{ge}(t) = \frac{i\mu}{4\hbar\gamma} \hat{E}_{\text{in}}(t)$  and thus the induced electric dipole operator

$$\hat{P}(t) = 2N\mu \hat{\sigma}_{ge}(t) = \frac{iN\mu^2}{2\hbar\gamma} \hat{E}_{\text{in}}(t). \quad (3)$$

In the optical thin regime, the radiation (or elastically scattered) field can be estimated as

$$\hat{E}_s(t) \approx \frac{ikL}{2\varepsilon_0} \hat{P}(t) = -\frac{\text{OD}}{4} \hat{E}_{\text{in}}(t), \quad (4)$$

where the optical depth is defined as  $\text{OD} = \alpha_0 L = (Nk\mu^2 L)/(\varepsilon_0 \hbar \gamma)$ . Here,  $\alpha_0$  is the on-resonance absorption coefficient.

As shown in Eq. (4), the strength of elastically scattered field (operator) is proportional to the input field but with a negative sign. At  $\text{OD} = 4$ ,  $\hat{E}_s = -\hat{E}_{\text{in}}$ , and a complete destructive interference occurs. Equivalently, from the observer's viewpoint (the detector in Fig. 1), the photon is completely absorbed but not reemitted. The probability of finding an atom in the excited state accumulates, and the strength of the induced electric dipole in Eq. (3) grows exponentially, but the reemission (or scattering) into the same mode as that of the input photon is completely suppressed. As  $t > 0$  after the incident photon wave packet is

switched off, the interference turns off and the photon is then reemitted. Hence, the single-photon absorption and reemission processes are well separated in time. One can also understand this as a storage process: the photon quantum state is converted into the atomic state which is reemitted back to the photon in the same optical mode at a later time. This quantum storage process is induced by the single-photon self interference, which is different from the quantum memories based on electromagnetically induced transparency [18–20].

In the above discussion, we solve the photon field perturbatively to get insight into the physics picture. We also performed a numerical simulation based on the linear dispersion theory, which more precisely predicts the complete destructive interference condition at an OD value of more than 6. This difference is mainly caused by the propagation and reabsorption of  $\hat{E}_s$  inside the medium, which is not taken into account in the above simple first-order perturbative analysis.

The experimental configuration we use to study the single-photon absorption and emission is illustrated in Fig. 2(a). The setup is composed of two two-dimensional  $^{85}\text{Rb}$  magneto-optical traps (MOT) with a length  $L = 1.5$  cm [21]. In MOT1, narrow-band paired Stokes ( $\omega_s$ ) and anti-Stokes ( $\omega_{as}$ ) photons are produced via the spontaneous four-wave mixing nonlinear process in the presence of counterpropagating pump ( $\omega_p$ , 780 nm, 10  $\mu\text{W}$ ) and coupling ( $\omega_c$ , 795 nm, 1 mW) laser beams [22]. The pump laser is blue detuned by 60 MHz from  $|1\rangle \rightarrow |4\rangle$  transition, and the coupling laser is on resonance with the  $|2\rangle \rightarrow |3\rangle$  transition. Both the pump and coupling lasers have the same collimated beam diameter of 1.6 mm. The Stokes photons are coupled into a single-mode fiber (SMF) and detected by a single-photon counter  $D_1$ . The anti-Stokes photons are coupled into and pass through a fiber-connected amplitude electro-optical modulator (EOM, EOspace, 10 GHz), which is driven by a waveform function generator (Tektronix AFG3252) triggered by the detection of Stokes photons. In this way, we are able to generate heralded single anti-Stokes photons with controllable waveforms [23]. Then the anti-Stokes photon propagates through a two-level cold atomic ensemble in MOT2 where all the atoms are prepared in the ground state  $|g\rangle = |1\rangle$ . The anti-Stokes photon's single mode, with a  $1/e^2$  beam diameter of 245  $\mu\text{m}$  at the waist, is focused to the center of MOT2, coupled into another SMF, and detected by a second single-photon counter  $D_2$ . The two-photon coincidence counts between the detectors  $D_1$  and  $D_2$  are recorded by a time-to-digit converter (Fast Comtec P7888). We run the experiment with a repetition rate of 600 Hz and a duty cycle of 30% [21].

We first characterize the photon source. The OD of MOT1 in the anti-Stokes transition is maintained at 25. Figure 2(b) displays the heralded anti-Stokes photon waveform without atoms in MOT2, measured as coincidence

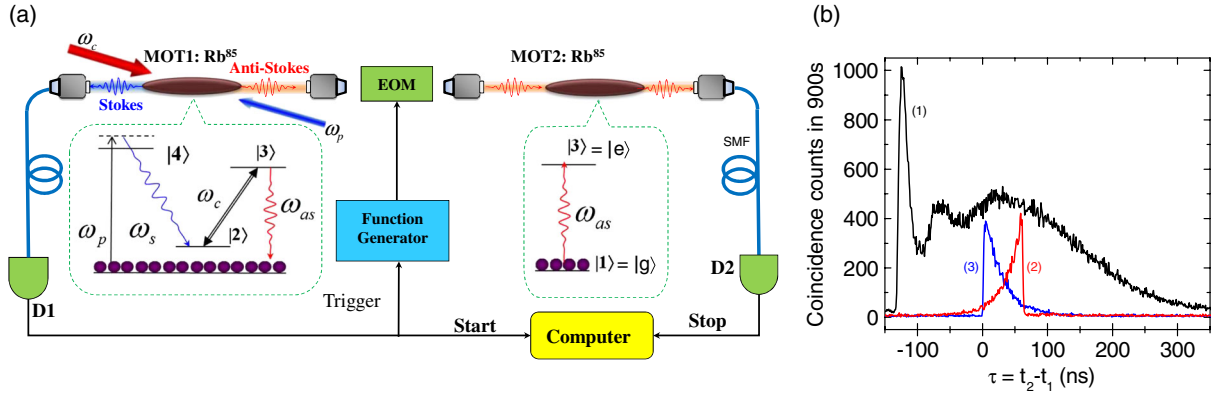

FIG. 2 (color online). (a) Experimental setup. The  $^{85}\text{Rb}$  energy levels are  $|1\rangle = |5S_{1/2}, F=2\rangle$ ,  $|2\rangle = |5S_{1/2}, F=3\rangle$ ,  $|3\rangle = |5P_{1/2}, F=3\rangle$ , and  $|4\rangle = |5P_{3/2}, F=3\rangle$ . (b) Two-photon coincidence counts collected for 900 s with 1 ns bin width between the detectors  $D_1$  and  $D_2$ , with no atoms in MOT2.  $\tau$  is the relative time between the anti-Stokes photon detection time  $t_2$  at  $D_2$  and the Stokes trigger time  $t_1$  at  $D_1$ . Plot (1) is measured without the EOM modulation. Plots (2) and (3) are the exponential growth and decay waveforms shaped by the EOM, respectively.

counts collected for 900 s with 1 ns bin width between the detectors  $D_1$  and  $D_2$ .  $\tau$  is the relative time between the anti-Stokes photon detection time  $t_2$  at  $D_2$  and the Stokes trigger time  $t_1$  at  $D_1$ . The plot (1) is the heralded narrow-band single-photon waveform without modulation; i.e., the EOM is fully open. The total measured coincidence counts are 133 476, corresponding to a photon pair detection rate of 148 pairs/s. Taking into account the detector quantum efficiency (50% each), fiber-fiber coupling efficiencies (70% at each MOT), EOM transmission (50%), filter efficiency (77% for Stokes channel and 76% for anti-Stokes channel), fiber connectors efficiency (81%), and the duty cycle, we estimate a generation rate of about 17 500 pairs/s from MOT1. The long temporal coherence time of more than 300 ns allows us to shape its waveform into predefined shapes, such as the exponential growth and decay waveforms shown in plots (2) and (3). Thus, the spontaneous four-wave mixing nonlinear process in MOT1 and the EOM amplitude modulation prepare and provide heralded single anti-Stokes photons with desired waveforms, which is on resonance with the two-level transition in MOT2.

Following the previous discussion, we send the heralded anti-Stokes photons into the two-level atomic medium in MOT2. By driving the EOM with a feedback control, we obtained an exponential growth waveform with a time constant equal to  $1/(2\gamma) = 26.5$  ns for the incident anti-Stokes photons, as shown in Fig. 3(a). Here,  $2\gamma = 2\pi \times 6$  MHz is the population decay rate in the excited state. At  $\tau = t_2 - t_1 = 0$ , the waveform is switched off with a fall time of 3 ns. Since we use a SMF to collect the transmitted anti-Stokes photons, the scattering of the anti-Stokes photons through incoherent spontaneous emission into the detector  $D_2$  is far below the noise level and can be neglected. Figure 3(b) shows the result at OD = 3. At this modest OD, during the exponential growth period ( $\tau < 0$ ), the photon waveform is only partially absorbed. After the

incident photon is switched off at  $\tau = 0$ , this partially absorbed waveform is released (reemitted) following an exponential decay curve that is determined by the lifetime  $[1/(2\gamma)]$  of the excited state. This exponential decay waveform is the free-induction decay induced by a single photon. This directional reemission efficiency, defined as the ratio of reemission to absorption, is 22%. As we increase

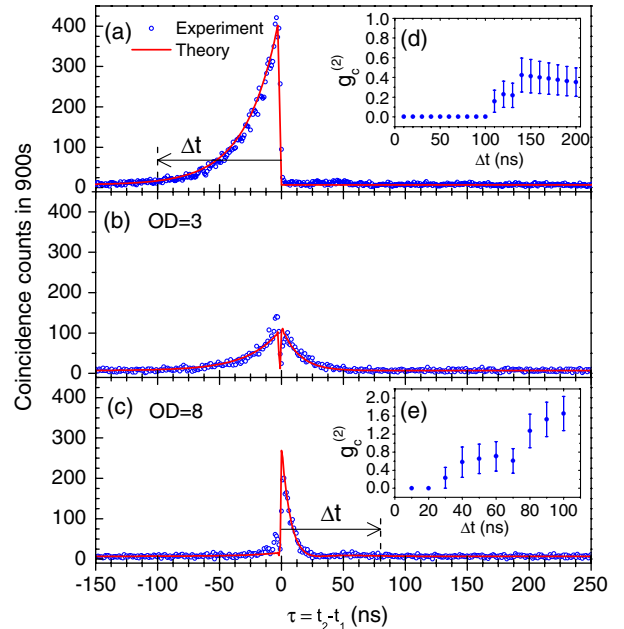

FIG. 3 (color online). Photon coincidence counts (between the detectors  $D_1$  and  $D_2$ ) after the heralded anti-Stokes photons with an exponential growth waveform pass through the two-level atomic ensemble at (a) OD = 0 (vacuum), (b) OD = 3, and (c) OD = 8. The exponential growth waveform in (a) has a time constant of 26.5 ns. The insets (d) and (e) show the measured conditional autocorrelation  $g_c^{(2)}$  as functions of coincidence window width.

the OD, the incident photon gets absorbed more heavily. At  $OD = 8$ , as shown in Fig. 3(c), the photon is completely absorbed and the probability in finding the reemitted photon at  $\tau < 0$  is nearly zero due to the destructive interference. As expected, at  $\tau > 0$ , the interference between the incident waveform and the emission disappears, and we observe the reemitted photon. While in the previous simple theoretical analysis we expected the reemitted photon waveform to have the same amplitude as the incident photon, in the experiment we find the reemitted photon has a reduced amplitude and shorter temporal length. This is mainly caused by the finite fall time (3 ns) at the falling edge of the waveform as well as the reabsorption and propagation effects that have not been taken into account previously. The efficiency of this directional photon re-emission is about 20%. The solid curves in (b) and (c) are obtained by using the frequency domain linear dispersion theory, and they agree with experiments very well.

We further verify the single-photon quantum nature by measuring the conditional autocorrelation function  $g_c^{(2)}$  of the anti-Stokes photon using a beam splitter [24]. The results are shown in Figs. 3(d) and 3(e), as functions of coincidence window width. It is clear that  $g_c^{(2)} < 0.5$  (the threshold of two-photon events) holds well within the waveform temporal length and confirms that both incident and reemitted waveforms are indeed in the single-photon state.

On the other side, a single photon with an exponential decay waveform behaves differently. As shown in Fig. 4(a), the exponential decay waveform has the same time constant as that in the exponential growth case [Fig. 3(a)]. The transmitted waveforms after passing through the two-level atomic ensemble at  $OD = 3$  and  $8$  are shown in Figs. 4(b) and 4(c). It is obvious that the absorption and re-emission both occur during the single-photon pulse duration ( $\tau > 0$ ), which leads to the waveform distortion. The measurement of the conditional autocorrelation functions, shown as the insets Figs. 4(d) and 4(e), confirm that both the incident and transmitted cases are single-photon waveforms.

In conclusion, we have studied the coherent interaction between a single photon and a two-level cold atomic ensemble, whose OD can be experimentally varied. We find that for a photon with an exponential growth waveform, the quantum interference between the incident wave packet and the scattering wave packet can be used to switch off the emission process on demand. As we turn off the interference, the absorbed photon can be reemitted into the same spatial mode as that of the incident wave. This is confirmed experimentally using narrow-band heralded single photons with controllable waveforms. At  $OD = 8$ , we observe a well-defined time boundary ( $\tau = 0$ ) between the absorption and re-emission processes. On the other side, a single photon with an exponential decay waveform behaves differently. Even at  $OD = 8$ , there is no complete absorption, and the transmitted photon waveform is

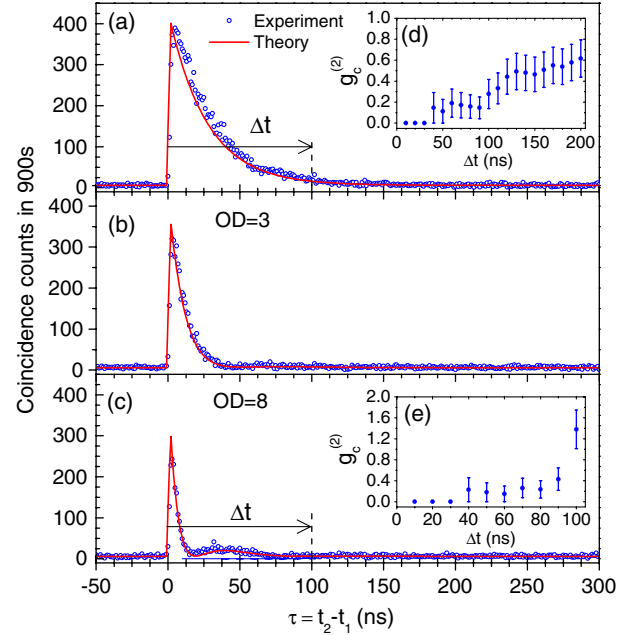

FIG. 4 (color online). Photon coincidence counts (between the detectors  $D_1$  and  $D_2$ ) after the heralded anti-Stokes photons with an exponential decay waveform pass through the two-level atomic ensemble at (a)  $OD = 0$  (vacuum), (b)  $OD = 3$ , and (c)  $OD = 8$ . The exponential decay waveform in (a) has a time constant of 26.5 ns. The insets (d) and (e) show the measured conditional autocorrelation  $g_c^{(2)}$  as functions of coincidence window width.

distorted. Our results confirm that the interaction between a single-photon wave packet and two-level atoms is a coherent process, even though there is no induced macroscopic electric dipole. We show that this coherent process can be manipulated by controlling the photon waveform in the time domain. Even though our experiment was performed in free space, the technique may be extended for cavity quantum electrodynamics [17,25,26].

We recognize that the use of amplitude EOM in this work introduces unavoidable insertion loss and waveform shaping loss of single photons. This problem can be overcome using single photons with controlled temporal waveform produced directly from atom-cavity-based schemes [27,28]. Other lossless single-photon shaping techniques may implement phase-frequency modulation [29] and dispersion compensation [30]. In a three-level atomic system (such as electromagnetically induced transparency [6,31]) with an additional control laser field, a single photon with an arbitrary temporal profile can be captured efficiently by either a single atom strongly coupled inside an optical cavity [32,33] or an atomic ensemble at a high OD in free space [34,35].

The authors thank S.E. Harris and Y. Silberberg for stimulating and helpful discussions. The work was supported by the Hong Kong Research Grants Council (Project No. 601411).

- \*dusw@ust.hk
- [1] C. J. Foot, *Atomic Physics* (Oxford University, New York, 2005).
- [2] A. Einstein, *Dtsch. Phys. Ges.* **18**, 318 (1916).
- [3] C. K. Carniglia, L. Mandel, and K. H. Drexhage, *J. Opt. Soc. Am.* **62**, 479 (1972).
- [4] M. Tanaka, M. Fujiwara, and H. Ikegami, *Phys. Rev. A* **34**, 4851 (1986).
- [5] F. Y. Wu, S. Ezekiel, M. Ducloy, and B. R. Mollow, *Phys. Rev. Lett.* **38**, 1077 (1977).
- [6] S. E. Harris, *Phys. Today* **50**, 36 (1997).
- [7] L. V. Hau, S. E. Harris, Z. Dutton, and C. H. Behroozi, *Nature (London)* **397**, 594 (1999).
- [8] M. A. I. Talukder, Y. Amagishi, and M. Tomita, *Phys. Rev. Lett.* **86**, 3546 (2001).
- [9] H. J. Kimble, M. Dagenais, and L. Mandel, *Phys. Rev. Lett.* **39**, 691 (1977).
- [10] S. Du, J. Wen, M. H. Rubin, and G. Y. Yin, *Phys. Rev. Lett.* **98**, 053601 (2007).
- [11] M. O. Scully, E. S. Fry, C. H. R. Ooi, and K. Wodkiewicz, *Phys. Rev. Lett.* **96**, 010501 (2006).
- [12] H. J. Kimble, *Nature (London)* **453**, 1023 (2008).
- [13] M. Stobińska, G. Alber, and G. Leuchs, *Europhys. Lett.* **86**, 14007 (2009).
- [14] Y. Wang, J. Minář, L. Sheridan, and V. Scarani, *Phys. Rev. A* **83**, 063842 (2011).
- [15] M. Sondermann, R. Maiwald, H. Konermann, N. Lindlein, U. Peschel, and G. Leuchs, *Appl. Phys. B* **89**, 489 (2007).
- [16] G. Leuchs and M. Sondermann, *Phys. Scr.* **85**, 058101 (2012).
- [17] E. Rephaeli, J.-T. Shen, and S. Fan, *Phys. Rev. A* **82**, 033804 (2010).
- [18] C. Liu, Z. Dutton, C. H. Behroozi, and L. V. Hau, *Nature (London)* **409**, 490 (2001).
- [19] S. Zhang, S. Zhou, M. M. T. Loy, G. K. L. Wong, and S. Du, *Opt. Lett.* **36**, 4530 (2011).
- [20] S. Zhou, S. Zhang, C. Liu, J. F. Chen, J. Wen, M. M. T. Loy, G. K. L. Wong, and S. Du, *Opt. Express* **20**, 24124 (2012).
- [21] S. Zhang, J. F. Chen, C. Liu, S. Zhou, M. M. T. Loy, G. K. L. Wong, and S. Du, *Rev. Sci. Instrum.* **83**, 073102 (2012).
- [22] S. Du, P. Kolchin, C. Belthangady, G. Y. Yin, and S. E. Harris, *Phys. Rev. Lett.* **100**, 183603 (2008).
- [23] P. Kolchin, C. Belthangady, S. Du, G. Y. Yin, and S. E. Harris, *Phys. Rev. Lett.* **101**, 103601 (2008).
- [24] P. Grangier, G. Roger, and A. Aspect, *Europhys. Lett.* **1**, 173 (1986).
- [25] T. Aoki, A. S. Parkins, D. J. Alton, C. A. Regal, B. Dayan, E. Ostby, K. J. Vahala, and H. J. Kimble, *Phys. Rev. Lett.* **102**, 083601 (2009).
- [26] J.-T. Shen and S. Fan, *Phys. Rev. A* **79**, 023837 (2009).
- [27] M. Keller, B. Lange, K. Hayasaka, W. Lange, and H. Walther, *Nature (London)* **431**, 1075 (2004).
- [28] G. S. Vasilev, D. Ljunggren, and A. Kuhn, *New J. Phys.* **12**, 063024 (2010).
- [29] H. P. Specht, J. Bochmann, M. Mücke, B. Weber, E. Figueroa, D. L. Moehring, and G. Rempe, *Nat. Photonics* **3**, 469 (2009).
- [30] S. E. Harris, *Phys. Rev. Lett.* **98**, 063602 (2007).
- [31] M. Mücke, E. Figueroa, J. Bochmann, C. Hahn, K. Murr, S. Ritter, C. J. Villas-Boas, and G. Rempe, *Nature (London)* **465**, 755 (2010).
- [32] J. Dilley, P. Nisbet-Jones, B. W. Shore, and A. Kuhn, *Phys. Rev. A* **85**, 023834 (2012).
- [33] A. D. Boozer, A. Boca, R. Miller, T. E. Northup, and H. J. Kimble, *Phys. Rev. Lett.* **98**, 193601 (2007).
- [34] A. V. Gorshkov, A. André, M. Fleischhauer, A. S. Sørensen, and M. D. Lukin, *Phys. Rev. Lett.* **98**, 123601 (2007).
- [35] I. Novikova, N. B. Phillips, and A. V. Gorshkov, *Phys. Rev. A* **78**, 021802(R) (2008).