

## Phase-Dependent Electron-Ion Recombination in a Microwave Field

K. R. Overstreet, R. R. Jones, and T. F. Gallagher

*Department of Physics, University of Virginia, Charlottesville, Virginia 22904-4714, USA*

(Received 14 December 2010; published 21 January 2011)

Using picosecond laser photoionization of Li in a microwave field we have observed phase-dependent recombination of the photoelectrons with their parent  $\text{Li}^+$  ions. Recombination occurs at phases of the microwave field such that energy is removed from the photoelectron in the first microwave cycle after excitation, and there are two maxima in the recombination in each microwave cycle. These observations are consistent with observations made using an attosecond pulse train phase locked to an infrared pulse and with the “simpleman’s” model, modified to account for the fact that the photoelectrons are produced in a Coulomb potential.

DOI: 10.1103/PhysRevLett.106.033002

PACS numbers: 32.80.Rm, 78.60.–b

Short wavelength extreme ultraviolet (XUV) attosecond pulses phase synchronized with infrared (IR) laser fields can be used to both characterize the field of the infrared pulse and to create electronic wave packets under controllable conditions [1–3]. In contrast to forming a continuum wave packet with the IR alone, which usually produces near zero energy electrons, at the temporal peak of the IR field, excitation by an XUV pulse in the presence of an IR field can produce an electronic wave packet at any energy and phase of the IR field. Furthermore, the IR field does not have to be so strong that it significantly alters the atomic potential.

Elegant examples of the use of phase synchronized pulses are the experiments of Johnsson *et al.* and Ranitovic *et al.*, who ionized He atoms with attosecond XUV pulse trains synchronized with IR fields [2,3]. The XUV photons alone are not energetic enough to photoionize He. However, if the XUV pulse arrives when the IR field is present, ionization is possible, and it exhibits a clear dependence on the phase of the IR field at which the XUV excitation occurs. For future use it is convenient to label the XUV field the high frequency field and the IR field the low frequency field. The essential physics behind such phenomena is often described by the classical simpleman’s model, in which the electron is assumed to be created in a flat potential and gains energy from or loses it to the low frequency field. The simpleman’s model was originally developed to describe above threshold ionization [4–6], and it is an excellent approximation in cases in which there is high frequency excitation far above the ionization limit or very strong low frequency fields [1,7–9]. In these terms the excitation of He occurs at an IR phase such that the He electron gains energy from the IR field.

In the He experiments the XUV excitation is to energies below the ionization limit, where the simpleman’s model is inapplicable, due to the neglect of the Coulomb potential. A more subtle shortcoming of the simpleman’s model is that it grossly underestimates the energy transfer to or from the low frequency field, as shown by frequency

domain measurements of microwave induced above threshold recombination [10]. A modification of the simpleman’s model taking into account the Coulomb potential provides an excellent description of the energy transfer in microwave induced above threshold recombination. Here we report time domain observations showing that the same process exhibits the dependence on the microwave phase expected of a simpleman’s model.

Specifically, we have observed that photoelectrons produced by a picosecond (ps) 819 nm laser pulse are recombined with their parent ions if the excitation occurs at the phase of a 17.43 GHz microwave field such that the microwave field extracts energy from the electron. The essential physics is similar to that observed by Johnsson *et al.* and Ranitovic *et al.* [2,3], except the frequencies are different and the sign of the energy transfer from the low frequency field is reversed. In our case the 819 nm pulse instead of the XUV pulse is the high frequency field, and the 17.43 GHz microwave field, instead of the IR field, is the low frequency field. In both the He experiments and this one the high frequency excitation is to the vicinity of the ionization limit, and simpleman’s model fails. In the sections which follow we outline the modified simpleman’s model, describe our experiment, present the results confirming the model, and discuss the implications of the related experimental work.

The essential features of the problem are shown in the one-dimensional picture of Fig. 1. The ps laser excites atoms to an energy  $W_0$  just above the ionization limit at a well-defined phase of the microwave field. As electrons leave the ion core, at  $r \approx 0$ , the microwave field accelerates them to the left or right. Here  $r$  is the distance of the electron from the ion. A photoelectron produced at time  $t_A$ , at the peak of the microwave field, is accelerated to the left. If the electron is ejected to the left it begins to gain energy, and if it is ejected to the right it begins to lose energy. A photoelectron produced at  $t_B$ , a zero crossing of the field, experiences no acceleration at the instant it is excited. If the electron is created in the microwave field

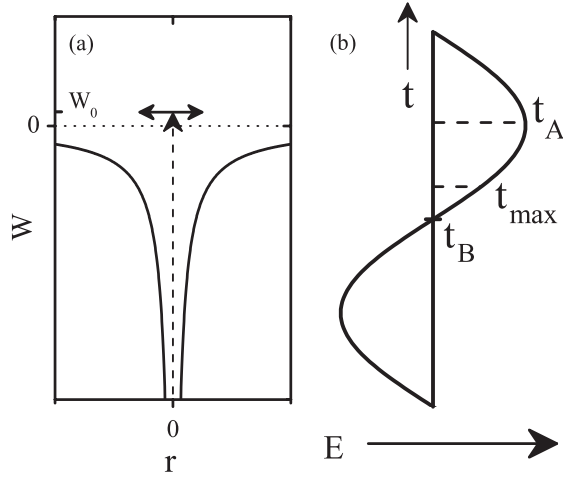

FIG. 1. (a) Excitation in a one-dimensional potential by a ps laser, shown by the broken arrow, at a well-defined phase of the microwave field, as shown in (b). Laser excitation produces electrons moving both to the left and the right from  $r \approx 0$  in the Coulomb potential. With excitation at  $t_A$ , at a microwave field maximum, electrons are accelerated to the left, and electrons ejected to the left begin to gain energy, while those ejected to the right begin to lose energy. There is no instantaneous force if the electrons are ejected at  $t_B$ , a zero crossing of the field, but the acceleration is in the same direction for the entire first half microwave cycle. The maximum time integrated energy transfer from the field occurs when the excitation occurs at  $\omega t_{\max} \cong \pi/6$ .

$E(t) = E \sin \omega t$  at time  $t_0$ , the energy which has been transferred from the microwave field to the electron at a later time  $t$  is given by [10]

$$W(t) = \int_{t_0}^t E(t') p(t') dt', \quad (1)$$

where  $p(t)$  is the momentum of the electron at time  $t$ . Unless otherwise noted, we use atomic units throughout. When the electron is near the core  $p(t) = \sqrt{2}/r$ , and, as a result, the dominant contribution to  $W$  occurs during the first half cycle of the microwave field, when the electron's momentum is largest. The physics is very similar to analyzing the electron's momentum with a half cycle field pulse [11].

In the microwave field  $E \sin \omega t$  the maximum energy transfer occurs for  $\omega t_0 = \pi/6$ , shown by  $t_{\max}$  in Fig. 1(b). This time is between excitation at the field maximum,  $\omega t_0 = \pi/2$ , shown by  $t_A$  in Fig. 1(b), and excitation at  $t_B$ , the zero crossing, where the field does not change sign for half a period. For relatively weak fields and laser excitation to energies near the limit,  $W_0 \approx 0$ , Eq. (1) can be reduced to a simple expression for the maximum energy transfer to or from the field. Explicitly,

$$W_{\max} = \frac{E}{\omega^{2/3}}, \quad (2)$$

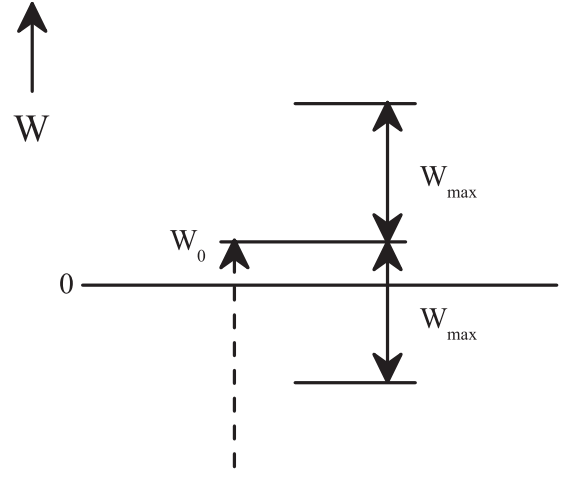

FIG. 2. If the ps laser excitation to energy  $W_0$  occurs at  $\omega t_0 = \omega t_{\max} = \pi/6$ , energy transfer up and down by  $W_{\max}$  occurs. If  $W_{\max} > W_0$ , recombination can occur.

which is in excellent agreement with the experimental observations of Shuman *et al.* [10] and Gurian *et al.* [12].

In Fig. 2 we show an expanded view of the energy region near the ionization limit. If excitation occurs to energy  $W_0$ , slightly above the limit, laser excitation at the microwave phase  $\omega t_0 = \pi/6 + n\pi$ , where  $n$  is an integer, leads to the maximum energy transfer  $W_{\max}$  up and down in energy, as shown, since the laser excitation produces photoelectrons going to the left and the right. In contrast, excitation at  $\omega t_0 = \pi/6 + (n + 1/2)\pi$  leads to no energy transfer. For recombination to occur requires  $W_{\max} > W_0$ .

In the experiment a beam of Li atoms passes through a microwave cavity where atoms are excited by an 819 nm ps laser pulse to a band of energies centered 125 GHz above the ionization limit. The excitation occurs at a well-defined phase of a 17.43 GHz microwave field, which is turned off 50 ns after the laser pulse. The recombined atoms are then detected by a field ionization pulse. The resulting electrons are ejected from the interaction region through a hole in the upper field plate and detected by a dual microchannel plate detector.

The laser excitation occurs at a 1 kHz repetition rate. Two 20 ns dye laser pulses at 670 and 610 nm drive the  $2s \rightarrow 2p$  and  $2p \rightarrow 3d$  transitions [13], and a 2 ps 819 nm pulse drives the  $3d \rightarrow \epsilon f$  transition. The 670 and 610 nm laser beams are 0.5 mm in diameter and propagate along the axis of the microwave cavity. They are crossed by the 2.2 mm diameter 819 nm ps laser beam at the microwave field antinode in the center of the cavity, producing a pencil shaped sample of atoms which experiences the same microwave field to within 3%. The uncertainty in the position of the ps laser beam relative to the microwave field maximum is 10%. The 819 nm pulse originates in a mode locked Ti:sapphire oscillator which runs at a 91 MHz repetition rate and is amplified at a 1 kHz repetition rate in a regenerative amplifier. Using a mask in the stretcher

or compressor of the regenerative amplifier we convert the 100 fs pulses of the oscillator into 2 ps pulses. The mask is used to tune the laser.

The 91 MHz pulse train of the Ti:sapphire oscillator is detected with a 25 GHz bandwidth photodiode, producing a microwave frequency comb. We phase lock the microwave oscillator, a Hewlett Packard (HP) 8350B/83550A sweep oscillator, to the 191st harmonic of 91 MHz, and the jitter between the microwave field and the ps laser pulse is 3 ps, comparable to the pulse width of the ps laser and substantially shorter than the microwave period of 56 ps. The output of the sweep oscillator is formed into 500 ns long pulses with a HP 11720 pulse modulator, amplified to a maximum power of 400 mW and sent by coaxial cable to the microwave cavity inside the vacuum chamber. The phase of the microwave field at which the ps laser excitation occurs is controlled by sending the ps laser beam through an optical delay line.

The Fabry-Perot microwave cavity is composed of two brass mirrors of 10.2 cm radius of curvature with an on axis separation of 7.91 cm. Since the cavity  $Q = 2900$ , the energy filling time of the cavity is 27 ns. There are field plates, separated by 8 cm, above and below the region between the mirrors which are used for field ionization. A similar pair of plates on the sides of the cavity, the field plates, and the cavity mirrors are separately biased to reduce stray fields to less than 3 mV/cm.

In Fig. 3 we show the recombination field ionization signal obtained when scanning the delay of the ps laser. The center frequency of the ps laser is tuned 125 GHz over

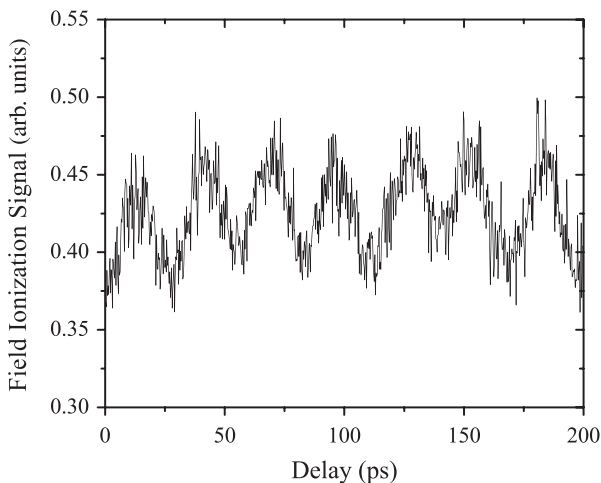

FIG. 3. Field ionization signal as a function of the time delay of the ps laser pulse relative to the 17.43 GHz microwave field, which has an amplitude of 70 V/cm and a period of 56 ps. The signal level with no microwave field, due to the low frequency wing of the ps laser which excites bound Rydberg atoms, is 1.00 on this scale. The total number of atoms excited by the ps laser is 100 on this scale. The observed signal exhibits the expected 28 ps period, corresponding to two maxima per microwave cycle.

the ionization limit and its bandwidth is approximately 250 GHz. The microwave field amplitude is 70 V/cm. In the absence of a microwave field there is a constant background signal, with an amplitude of 1.00 on the scale of Fig. 3. It comes from field ionization of bound atoms excited by the low frequency wing of the ps laser. The background signal represents 1% of the total excitation by the ps laser. Adding the microwave field produces the signal shown in Fig. 3. The background signal decreases due to microwave ionization of the high  $n$  states produced by the low frequency tail of the ps laser. More important, we observe a sinusoidal oscillation with a 28 ps period. The Fourier transform of the signal gives a frequency of 35(3) GHz, twice the microwave frequency, as expected on the basis of the discussion of Figs. 1 and 2.

Although we do not show it here, if the ps laser is tuned below the ionization limit we observe an increase in the ionization signal, analogous to that observed by Johnsson *et al.* and Ranitovic *et al.* [2,3], at the same phase at which we observe the maximum recombination signal shown in Fig. 3. Energy transfer to both higher and lower energies occurs at the same microwave phase, as suggested by Figs. 1 and 2.

We are able to see the recombination for the ps laser tuned over a 50 GHz range centered 125 GHz over the limit. At lower laser frequencies there are so many bound atoms that any recombination signal is partially cancelled by ionization of bound atoms and generally drowned in the noise. At higher laser frequencies we believe the signal disappears due to stray fields which inhibit the recombination.

In Fig. 4 we show the dependence on the microwave field amplitude with the laser tuned 125 GHz above the limit. Open circles represent the phase-average signal, and filled circles represent the peak-to-peak recombination signal, multiplied by 10. Since the microwave field can ionize the bound atoms excited by the low frequency tail of the ps laser, it is not particularly surprising that the phase-average field ionization signal decreases with increasing microwave field. In contrast, the phase-dependent recombination signal increases with microwave field, exhibits a peak at approximately 35 V/cm, and then decreases.

As shown by Fig. 2 and Eq. (2), our simple picture predicts recombination to occur up to the energy  $W_{\max}$  above the limit, so we expect the phase-dependent recombination signal to increase until  $W_{\max} = 250$  GHz, the ps laser bandwidth, and then remain constant. For a 17.43 GHz field  $W_{\max} = 250$  GHz at  $E = 35$  V/cm, so we would expect something approximately like the solid line of Fig. 4, which matches the data for fields less than 35 V/cm but not for higher fields.

A substantial part of the decrease in the recombination signal at fields above 35 V/cm can be attributed to microwave ionization later in the pulse, a process which we have ignored. The similar fractional decrease of the

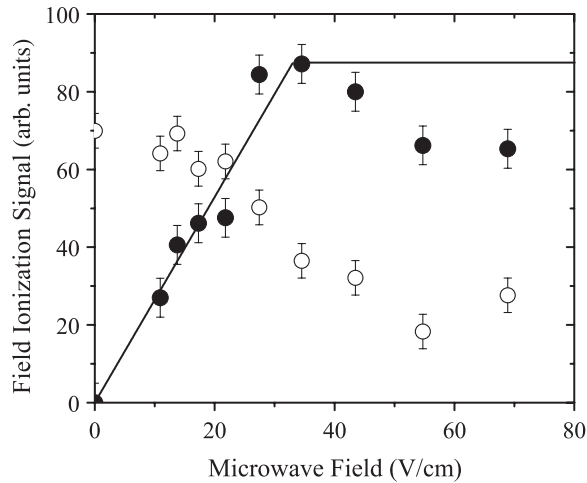

FIG. 4. Microwave field dependence of the field ionization, or recombination, signal. The phase-averaged signal (○) decreases with the microwave field. It is present, even with no microwave field, due to excitation of bound Rydberg atoms by the low frequency wing of the ps laser. The peak-to-peak phase sensitive signal, multiplied by 10 (●) rises with the microwave field to a peak at a field of 30 V/cm and then declines. The expected field dependence based on Eq. (2) and the ps laser bandwidth (solid line).

phase-averaged and phase-dependent recombination signals at fields above 35 V/cm suggests the importance of microwave ionization of the bound atoms excited by the low frequency wing of the ps laser and of the recombined atoms. In the frequency domain recombination experiments, while the energy extent above the limit increases with field according to Eq. (2), the amplitude of the signal for a specific laser tuning close to the limit often decreases [10,12]. Since our ps laser excitation only addresses a 250 GHz wide band just above the limit, as the extent of the above threshold recombination grows beyond 250 GHz the recombination signal decreases.

It is useful to compare our ps (microwave) experiments with the analogous attosecond pulse train (IR) experiments. In both cases the energy transfer from the low frequency field depends on the phase of the low frequency field at which the high frequency pulse arrives. We have observed only a small phase dependence using a single ps pulse, and the result for a single attosecond pulse is calculated to be similarly small [2]. In the attosecond case the observed effect is attributed to the coherent addition of amplitudes over multiple IR cycles, which implies that the electron returns to the ionic core on several cycles of the IR field and that the frequency domain spectrum should be periodic at the IR frequency.

In frequency domain experiments analogous to the one reported here, we have observed structure periodic at the microwave frequency. Collectively, these observations suggest that quasistable Floquet states are formed in both

cases, as suggested by Gurian *et al.* and Tong *et al.* [12,14]. In the He case, there are bound levels of He separated by frequencies close to the IR frequency, so it is easy to imagine a quasistable wave packet based on these coupled states. In our case the microwave frequency is far higher than the natural Kepler frequency of the states near the ionization limit, so any quasistable motion is that driven by the microwave field. If the electron is localized far from the ionic core, this motion is of small spatial amplitude with a variation in energy during the microwave field cycle equal to twice the ponderomotive energy. On the other hand, if the electron is nearer to the core the amplitude of the motion is larger, and so is the energy variation, as shown by Fig. 2. The stability arises from the states at which the electron is at long range, but we gain access to these states over a large energy range by means of the short range states.

In conclusion, we have observed the phase dependence of the recombination in a microwave field phase locked to a ps laser pulse. While the results cannot be explained by the original simpleman's model, they are completely consistent with its extension to include the Coulomb potential. The electron cannot be treated as a plane wave; the Coulomb potential must be taken into account. Finally, this and related work suggest a Floquet approach to the problem [15].

It is a pleasure to acknowledge useful conversations with A. Becker and C. L. Cocke. This work has been supported by the Department of Energy, Office of Basic Energy Sciences.

- 
- [1] E. Goulielmakis *et al.*, *Science* **305**, 1267 (2004).
  - [2] P. Johnsson *et al.*, *Phys. Rev. Lett.* **95**, 013001 (2005).
  - [3] P. Ranitovic *et al.*, *New J. Phys.* **12**, 013008 (2010).
  - [4] H.B. van Linden van den Heuvell and H.G. Muller, *Multiphoton Processes*, edited by S.J. Smith and P.L. Knight (Cambridge University Press, Cambridge, England, 1988).
  - [5] T.F. Gallagher, *Phys. Rev. Lett.* **61**, 2304 (1988).
  - [6] P.B. Corkum, N.H. Burnett, and F. Brunel, *Phys. Rev. Lett.* **62**, 1259 (1989).
  - [7] J.M. Schins *et al.*, *Phys. Rev. Lett.* **73**, 2180 (1994).
  - [8] M. Drescher *et al.*, *Nature (London)* **419**, 803 (2002).
  - [9] D.A. Tate, D.G. Papaioannou, and T.F. Gallagher, *Phys. Rev. A* **42**, 5703 (1990).
  - [10] E.S. Shuman, R.R. Jones, and T.F. Gallagher, *Phys. Rev. Lett.* **101**, 263001 (2008).
  - [11] R.R. Jones, *Phys. Rev. Lett.* **76**, 3927 (1996).
  - [12] J.H. Gurian, K.R. Overstreet, H. Maeda, and T.F. Gallagher, *Phys. Rev. A* **82**, 043418 (2010).
  - [13] J.H. Gurian, H. Maeda, and T.F. Gallagher, *Rev. Sci. Instrum.* **81**, 073111 (2010).
  - [14] X.M. Tong *et al.*, *Phys. Rev. A* **81**, 021404 (2010).
  - [15] A. Giusti-Suzor and P. Zoller, *Phys. Rev. A* **36**, 5178 (1987).