

## Characterization of Collective Gaussian Attacks and Security of Coherent-State Quantum Cryptography

Stefano Pirandola,<sup>1</sup> Samuel L. Braunstein,<sup>2</sup> and Seth Lloyd<sup>1,3</sup>

<sup>1</sup>Research Laboratory of Electronics, MIT, Cambridge, Massachusetts 02139, USA

<sup>2</sup>Computer Science, University of York, York YO10 5DD, United Kingdom

<sup>3</sup>Department of Mechanical Engineering, MIT, Cambridge, Massachusetts 02139, USA

(Received 5 June 2008; published 14 November 2008)

We provide a simple description of the most general collective Gaussian attack in continuous-variable quantum cryptography. In the scenario of such general attacks, we analyze the asymptotic secret-key rates which are achievable with coherent states, joint measurements of the quadratures and one-way classical communication.

DOI: 10.1103/PhysRevLett.101.200504

PACS numbers: 03.67.Dd, 42.50.-p, 89.70.Cf

During recent years, quantum systems with infinite dimensional Hilbert spaces have become the object of increasing interest within the quantum information community [1]. These systems are generally called *continuous-variable* systems, and their standard prototype is given by the bosonic modes of the radiation field. In ordinary experiments in quantum optics, bosonic modes are generated in states with Gaussian statistics [2], and these statistics are commonly preserved during subsequent optical manipulation. Further, the Gaussian statistics can be preserved at the end of quantum communication lines (e.g., optical fibers), where noisy transformations of the state are induced by the interaction with an external environment. From a theoretical point of view, the standard model for this kind of transformation is represented by the one-mode Gaussian channel. This is a completely positive trace-preserving (CPT) map that transforms Gaussian states into Gaussian states, without creating any kind of correlation among the various bosonic modes. The mathematical structure of this map is relatively simple and has been further simplified in Ref. [3] via the introduction of canonical forms.

In the context of continuous-variable quantum key distribution (cvQKD), one-mode Gaussian channels can be interpreted as the effect of collective Gaussian attacks. Starting from this consideration, here we extend the results of Refs. [3,4] to provide a full characterization of the most general collective Gaussian attack in cvQKD. Recall that collective Gaussian attacks have been recognized as the most powerful collective attacks in cvQKD with Gaussian resources [5]. Furthermore, under suitable conditions [6], collective attacks have been recently proven to bound the most general attacks (coherent attacks) against cvQKD protocols. Using our general characterization of collective Gaussian attacks, we then analyze the security of a cvQKD protocol, where coherent states are used to generate secret correlations. Such a protocol is a simple generalization of the nonswitching protocol of Ref. [7], where further post-processing of the classical data is also used to compensate possible squeezing and rotation of the output quadratures.

Let us consider a single bosonic mode, whose quadratures  $\hat{\mathbf{x}}^T := (\hat{q}, \hat{p})$  satisfy  $[\hat{\mathbf{x}}, \hat{\mathbf{x}}^T] = 2i\mathbf{\Omega}$ , where the matrix  $\mathbf{\Omega}$  is defined by the entries  $\mathbf{\Omega}_{11} = \mathbf{\Omega}_{22} = 0$  and  $\mathbf{\Omega}_{12} = -\mathbf{\Omega}_{21} = 1$ . Every Gaussian state  $\rho$  [2] of the system is characterized by a displacement vector  $\bar{\mathbf{x}} := \text{Tr}(\hat{\mathbf{x}}\rho)$  and a covariance matrix  $\mathbf{V} := \text{Tr}\{[\hat{\mathbf{x}}\hat{\mathbf{x}}^T + (\hat{\mathbf{x}}\hat{\mathbf{x}}^T)^T]\rho\}/2 - \bar{\mathbf{x}}\bar{\mathbf{x}}^T$ . In a quantum communication scenario, this kind of state can be used by a sender (Alice) to transmit classical information to a receiver (Bob) through a noisy quantum channel. Usually, Alice chooses  $\rho(\bar{\mathbf{x}}, \mathbf{V})$  from an ensemble of *signal* states  $\mathcal{A} := \{p(\bar{\mathbf{x}}), \rho(\bar{\mathbf{x}}, \mathbf{V})\}$  encoding a classical variable  $X := \{p(\bar{\mathbf{x}}), \bar{\mathbf{x}}\}$ . This variable describes the modulation of the displacement  $\bar{\mathbf{x}}$  via some probability distribution  $p(\bar{\mathbf{x}})$ . The signal states are then sent to Bob, in independent uses of the quantum channel. At the output, Bob gets a noisy ensemble  $\mathcal{B}$ , whose (incoherent) detection gives a classical variable  $Y$  which is correlated to  $X$  (see Fig. 1, step 1). In this scenario, the standard model for the noise process is represented by the one-mode Gaussian channel. By definition, this channel is a CPT map  $\mathcal{G}$  acting on a single bosonic mode and preserving the Gaussian statistics of the input state. The mathematical description of this channel is fully contained in a triplet  $\{\mathbf{T}, \mathbf{N}, \mathbf{d}\}$ , where  $\mathbf{d}$  is an  $\mathbb{R}^2$  vector and  $\mathbf{T}, \mathbf{N}$  are  $2 \times 2$  real matrices [8]. Explicitly, the action of  $\mathcal{G}(\mathbf{T}, \mathbf{N}, \mathbf{d})$  on a Gaussian state  $\rho(\bar{\mathbf{x}}, \mathbf{V})$  corresponds to the simple transformations

$$\bar{\mathbf{x}} \rightarrow \mathbf{T}\bar{\mathbf{x}} + \mathbf{d}, \mathbf{V} \rightarrow \mathbf{T}\mathbf{V}\mathbf{T}^T + \mathbf{N}. \quad (1)$$

In particular, for  $\mathbf{N} = \mathbf{0}$  and  $\mathbf{T} := \mathbf{S}$  symplectic (i.e.,  $\mathbf{S}\mathbf{\Omega}\mathbf{S}^T = \mathbf{\Omega}$ ), the channel represents a Gaussian unitary. This means that we can set  $\mathcal{G}(\mathbf{S}, \mathbf{0}, \mathbf{d}) := \mathcal{U}(\mathbf{S}, \mathbf{d})$  where  $\mathcal{U}: \rho \rightarrow \hat{U}\rho\hat{U}^\dagger$  with  $\hat{U}$  a unitary operator.

Remarkably, the mathematical structure of  $\mathcal{G}(\mathbf{T}, \mathbf{N}, \mathbf{d})$  can be further simplified thanks to recent results of Ref. [3]. In fact, every  $\mathcal{G}(\mathbf{T}, \mathbf{N}, \mathbf{d})$  can be decomposed as  $\mathcal{G} = \mathcal{U}_B \circ \mathcal{C} \circ \mathcal{U}_A$ , where  $\{\mathcal{U}_A, \mathcal{U}_B\}$  are Gaussian unitaries, while the map  $\mathcal{C}$ , called the *canonical form*, represents a Gaussian channel with  $\mathbf{d} = \mathbf{0}$  and  $\mathbf{T}_c, \mathbf{N}_c$  diagonal. The explicit expressions of  $\mathbf{T}_c$  and  $\mathbf{N}_c$  depend on three symplectic invariants of the channel: the generalized *trans-*

mission  $\tau := \det \mathbf{T}$  (ranging from  $-\infty$  to  $+\infty$ ), the rank  $r := [\text{rk}(\mathbf{T})\text{rk}(\mathbf{N})]/2$  (with possible values  $r = 0, 1, 2$ ), and the temperature  $\bar{n}$  (which is a positive number related to  $\det \mathbf{N}$  [9]). These three invariants  $\{\tau, r, \bar{n}\}$  completely characterize the two matrices  $\mathbf{T}_c, \mathbf{N}_c$  and, therefore, the corresponding canonical form  $\mathcal{C} = \mathcal{C}(\tau, r, \bar{n})$ . In particular, the first two invariants  $\{\tau, r\}$  determine the class of the form [3]. The full classification is explicitly shown in the following Table

$\tau$	$r$	Class	Form	$\mathbf{T}_c$	$\mathbf{N}_c$
0	0	$A_1$	$\mathcal{C}(0, 0, \bar{n})$	$\mathbf{0}$	$(2\bar{n} + 1)\mathbf{I}$
0	1	$A_2$	$\mathcal{C}(0, 1, \bar{n})$	$\frac{\mathbf{I}+\mathbf{Z}}{2}$	$(2\bar{n} + 1)\mathbf{I}$
1	1	$B_1$	$\mathcal{C}(1, 1, 0)$	$\mathbf{I}$	$\frac{\mathbf{I}-\mathbf{Z}}{2}$
1	2	$B_2$	$\mathcal{C}(1, 2, \bar{n})$	$\mathbf{I}$	$\bar{n}\mathbf{I}$
1	0	$B_2(\text{Id})$	$\mathcal{C}(1, 0, 0)$	$\mathbf{I}$	$\mathbf{0}$
(0, 1)	2	$C(\text{Att})$	$\mathcal{C}(\tau, 2, \bar{n})$	$\sqrt{\tau}\mathbf{I}$	$(1 - \tau)(2\bar{n} + 1)\mathbf{I}$
$>1$	2	$C(\text{Amp})$	$\mathcal{C}(\tau, 2, \bar{n})$	$\sqrt{\tau}\mathbf{I}$	$(\tau - 1)(2\bar{n} + 1)\mathbf{I}$
$<0$	2	$D$	$\mathcal{C}(\tau, 2, \bar{n})$	$\sqrt{-\tau}\mathbf{Z}$	$(1 - \tau)(2\bar{n} + 1)\mathbf{I}$

In this Table, the values of  $\{\tau, r\}$  in the first two columns specify a particular class  $A_1, A_2, B_1, B_2, C$ , and  $D$  [10]. Within each class, the possible canonical forms are expressed in the third column, where also the third invariant  $\bar{n}$  must be considered. The corresponding expressions of  $\mathbf{T}_c, \mathbf{N}_c$  are shown in the last two columns, where  $\mathbf{Z} := \text{diag}(1, -1)$ ,  $\mathbf{I} := \text{diag}(1, 1)$  and  $\mathbf{0}$  is the zero matrix.

Thus, an arbitrary one-mode Gaussian channel  $\mathcal{G}(\mathbf{T}, \mathbf{N}, \mathbf{d})$  can be expressed by a unique canonical form  $\mathcal{C}(\tau, r, \bar{n})$  up to a pair of input-output Gaussian unitaries  $\{\mathcal{U}_A, \mathcal{U}_B\}$ . Now, it is known that every quantum channel can be represented by a unitary interaction coupling the signal system to an environment, prepared in some initial state  $\rho_E$ . When  $\rho_E$  is pure, such a dilation is called a ‘‘Stinespring dilation’’ and is unique up to partial isometries [11]. By extending the results of Ref. [4], we easily construct the Stinespring dilations of all the canonical forms. In detail, a generic  $\mathcal{C}(\tau, r, \bar{n})$  can be dilated to a three-mode Gaussian unitary corresponding to a symplectic transformation  $\mathbf{L} = \mathbf{L}(\tau, r)$  [12]. This transformation mixes the input state  $\rho_A$  with a two-mode squeezed vacuum (TMSV) state  $|w\rangle_E$  of variance  $w = 2\bar{n} + 1$  (see Fig. 1, step 2). Compactly, we denote by  $\{\mathbf{L}(\tau, r), |w\rangle\}$  the Stinespring dilation of a generic canonical form  $\mathcal{C}(\tau, r, \bar{n})$ . For particular choices of the class  $\{\tau, r\}$ , this dilation corresponds to well-known Gaussian models of interaction. In particular, for  $\{\tau, r\} = \{1, 2\}$ , it corresponds to a universal Gaussian cloner [13], while for  $0 < \tau < 1$  and  $r = 2$ , it describes an entangling cloner [14], i.e., a beam splitter of transmission  $\tau$  mixing the signal with one mode of the TMSV state  $|w\rangle$ .

Thus, every one-mode Gaussian channel  $\mathcal{G}(\mathbf{T}, \mathbf{N}, \mathbf{d})$  can be uniquely represented by the Stinespring dilation  $\{\mathbf{L}(\tau, r), |w\rangle\}$ , up to Gaussian unitaries  $\{\mathcal{U}_A, \mathcal{U}_B\}$  on the channel and isometries on the environment  $\tilde{\mathbf{E}}$ . By assuming an environment which is bounded in Euclidean space (i.e., a finite box), the total set of environmental modes is

countable. In such a case, the action of an isometry on  $\tilde{\mathbf{E}}$  is equivalent to a unitary  $\hat{U}_E$  involving the two output ancillas  $\tilde{\mathbf{E}}$  and all the remaining ancillas  $\mathbf{e} = \{e_i\}_{i=1}^\infty$  of the environment (prepared in the vacuum state). In other words,  $\mathcal{G}(\mathbf{T}, \mathbf{N}, \mathbf{d})$  can be represented by the maximal Stinespring dilation  $\{\mathbf{L}(\tau, r) \oplus \mathbf{I}_e, |w\rangle \otimes |0\rangle_e\}$ , up to Gaussian unitaries  $\{\mathcal{U}_A, \mathcal{U}_B\}$  on the channel and unitaries  $\hat{U}_E$  on the environment  $\{\tilde{\mathbf{E}}, \mathbf{e}\}$  (see Fig. 1, step 3) [15].

Let us now consider the standard cryptographic scenario, where the whole environment is under control of a malicious eavesdropper (Eve). For each signal state, Eve can store the corresponding output ancillas  $\{\tilde{\mathbf{E}}, \mathbf{e}\}$  in a quantum memory, detectable by a coherent measurement  $\mathcal{M}_E$  at any time of the quantum communication. For infinite uses of the channel, the output ancillas  $\{\tilde{\mathbf{E}}, \mathbf{e}\}$  will provide an output ensemble of states  $\mathcal{E}$ . Such an ensemble

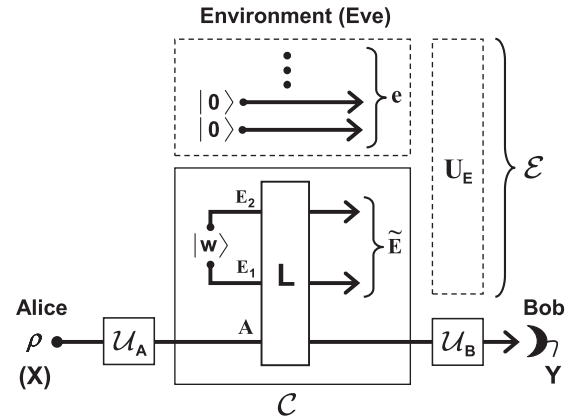

FIG. 1. The general scenario in five steps. (1) Quantum communication. Alice randomly picks signal states  $\rho$  from an ensemble  $\mathcal{A}$  encoding a classical variable  $X$ . At the output of the channel, Bob detects the states via a quantum measurement. The corresponding outcomes define an output classical variable  $Y$  correlated to  $X$ . (2) One-mode Gaussian channel. A one-mode Gaussian channel  $\mathcal{G}$  corresponds to a canonical form  $\mathcal{C}$  up to a pair of Gaussian unitaries  $\mathcal{U}_A$  (at the input) and  $\mathcal{U}_B$  (at the output). The central canonical form  $\mathcal{C}$  can be dilated to a symplectic interaction  $\mathbf{L}$  involving two ancillary modes  $\mathbf{E} := \{E_1, E_2\}$  prepared in a TMSV state  $|w\rangle_E$ . The dilation of the form is unique up to isometries acting on  $\tilde{\mathbf{E}} := \{\tilde{E}_1, \tilde{E}_2\}$ . (3) Maximal dilation. By assuming Eve is in a finite box, the dilation can be extended (via an identity) to the remaining modes  $\mathbf{e} = \{e_i\}_{i=1}^\infty$  of the environment (prepared in vacua). This maximal dilation of  $\mathcal{C}$  is now unique up to unitaries  $\hat{U}_E$  acting on  $\{\tilde{\mathbf{E}}, \mathbf{e}\}$ . (4) Collective Gaussian attack. All the output ancillas  $\{\tilde{\mathbf{E}}, \mathbf{e}\}$  provide an ensemble  $\mathcal{E}$ , which Eve can detect to estimate  $X$  or  $Y$ . By using an entropic bound for Eve’s accessible information, the extra ancillas and the extra unitary (dashed boxes in the figure) can be neglected. As a consequence, only the set  $G := \{\mathbf{L}(\tau, r), |w\rangle, \mathcal{U}_A, \mathcal{U}_B\}$  (solid boxes in the figure) is needed to characterize the attack. (5) Coherent-state protocol. Alice’s signal states  $\rho$  are coherent states  $|\alpha\rangle$  whose amplitudes encode a Gaussian variable ( $X = \alpha$ ). Bob’s measurement is a heterodyne detection retrieving the output amplitudes ( $Y = \beta$ ).

can be expressed in terms of Alice's variable  $X$  or Bob's variable  $Y$ . In other words, there always exist two coherent measurements,  $\mathcal{M}_E(X)$  and  $\mathcal{M}_E(Y)$ , which are optimal in the estimation of  $X$  and  $Y$ , respectively. This scenario represents the most general description for a collective Gaussian attack. Luckily, this description can be greatly simplified if we adopt a suitable "entropic bound" to restrict Eve's accessible information on her output ensemble  $\mathcal{E}$ . This bound can be provided by the Holevo information, but also by the quantum mutual information or, more generally, by the von Neumann entropy. On the one hand, this bound enables us to ignore the details of the quantum measurement  $\mathcal{M}_E$ . On the other, since the bound is unitarily invariant, the environmental unitary  $\hat{U}_E$  and the extra ancillas "e" can be also neglected. As a consequence, the attack's description can be reduced to the set  $G := \{\mathbf{L}(\tau, r), |w\rangle, \mathcal{U}_A, \mathcal{U}_B\}$ , where  $\{\tau, r, w\}$  are the channel symplectic invariants and  $\{\mathcal{U}_A, \mathcal{U}_B\}$  the input-output Gaussian unitaries (see Fig. 1, step 4). In particular, the Gaussian unitaries  $\{\mathcal{U}_A, \mathcal{U}_B\}$  are equivalent to a pair of displacements  $\{\mathbf{d}_A, \mathbf{d}_B\}$  and a pair of symplectic matrices  $\{\mathbf{M}_A, \mathbf{M}_B\}$ . These matrices may be written as  $\mathbf{M}_A = (\mathbf{a}_1, \mathbf{a}_2)^T$  and  $\mathbf{M}_B = (\mathbf{b}_1, \mathbf{b}_2)$ , where  $\{\mathbf{a}_1, \mathbf{a}_2, \mathbf{b}_1, \mathbf{b}_2\}$  are  $\mathbb{R}^2$  column-vectors. The scalar products of these vectors define three important parameters  $\{\theta, \theta_A, \theta_B\}$ , which contain the basic information about the noninvariant action of the attack. Explicitly, these parameters are  $\theta := |\mathbf{a}_1|^2|\mathbf{b}_1|^2 + 2(\mathbf{a}_1 \cdot \mathbf{a}_2)(\mathbf{b}_1 \cdot \mathbf{b}_2) + |\mathbf{a}_2|^2|\mathbf{b}_2|^2$ ,  $\theta_A := |\mathbf{a}_1|^2 + |\mathbf{a}_2|^2$  and  $\theta_B := |\mathbf{b}_1|^2 + |\mathbf{b}_2|^2$ . Using the Euler decomposition [2] of the symplectic matrices, we can prove the lower bounds [16]

$$\theta \geq 2, \quad \theta_A \geq 2, \quad \theta_B \geq 2. \quad (2)$$

Notice that we may call "canonical" the attacks of the form  $C := \{\mathbf{L}(\tau, r), |w\rangle, I_A, I_B\}$ , where  $I$  is the ideal channel (i.e., the identity map). For this kind of attack it is easy to prove the minimal condition  $\theta = \theta_A = \theta_B = 2$ .

Let us now analyze the security of a cvQKD protocol, which is a direct generalization of the nonswitching protocol of Ref. [7]. In this protocol, Alice prepares a coherent state  $|\alpha\rangle$  whose complex amplitude  $\alpha$  is randomly modulated by a Gaussian distribution with zero mean and variance  $\mu$ . Then, Alice sends  $|\alpha\rangle$  to Bob, who decodes a conditional amplitude  $\beta|\alpha$  by heterodyne detection. Such a process is repeated many times, with Bob getting an output random amplitude  $\beta$  (see Fig. 1, step 5). At the end of the quantum communication, part of the data  $\{\alpha, \beta\}$  is publicly disclosed by Alice and Bob. This step allows them to realize quantum tomography of the Gaussian channel  $\mathcal{G}(\mathbf{T}, \mathbf{N}, \mathbf{d})$ , which completely discloses  $\mathbf{T}$ ,  $\mathbf{N}$ , and  $\mathbf{d}$ . In fact, from the analysis of the first and second statistical moments, they can fully retrieve the two transformations of Eq. (1). Thanks to this information, Bob is able to process his classical data  $\beta$  in order to make an optimal estimation of Alice's signal  $\alpha$ . Such a classical

post-processing is equivalent to inverting the displacement transformation in Eq. (1), which generally involves squeezing and rotation of the two quadratures. Alternatively, Alice can exploit Eq. (1) to process her data  $\alpha$  and estimate Bob's variable  $\beta$ . The first situation corresponds to *direct reconciliation*, where  $\alpha$  is the reference variable, decoded by Bob with the help of one-way classical communication (CC) from Alice. By contrast, the second situation corresponds to *reverse reconciliation* [14], where  $\beta$  is the reference variable, decoded by Alice with the help of one-way CC from Bob. In both cases, the classical mutual information of Alice and Bob is given by  $I(\alpha:\beta) = H(\beta) - H(\beta|\alpha)$ , where  $H(\cdot|\cdot)$  is the Shannon entropy for bivariate Gaussian variables [17].

The Gaussian channel  $\mathcal{G}(\mathbf{T}, \mathbf{N}, \mathbf{d})$  between the users is the effect of a collective Gaussian attack. Bounding Eve with the Holevo information, this attack can be fully characterized by the set  $G := \{\mathbf{L}(\tau, r), |w\rangle, \mathcal{U}_A, \mathcal{U}_B\}$ . In this description, the Holevo information  $I(\gamma:E)$  of Eve on the reference variable  $\gamma = \alpha, \beta$  can be computed from the restricted set of ancillas  $\tilde{\mathbf{E}}$  (see Fig. 1). The secret-key rate  $R$  of the protocol is then equal to  $R = \max\{0, R(\alpha), R(\beta)\}$ , where  $R(\gamma) := I(\alpha:\beta) - I(\gamma:E)$  is the rate with respect to Alice's variable  $\gamma = \alpha$  (direct reconciliation) or Bob's variable  $\gamma = \beta$  (reverse reconciliation). Let us consider the asymptotic secret-key rate  $R_\infty := \lim_{\mu} R$  that can be reached in the limit of high modulation ( $\mu \rightarrow +\infty$ ). Here, we consider all the values of the transmission  $\tau$  with the exception of  $\tau = 1$ . The asymptotic rate  $R_\infty$  can be easily proven to be zero for every  $\tau \leq 0$  [16]. By contrast, in the positive region  $0 < \tau \neq 1$ , the explicit formula of  $R_\infty$  is extremely hard to compute. For this reason, we provide a lower bound  $B_\infty \leq R_\infty$  which has the nontrivial advantage of further simplifying the description of the attack. Therefore, we only consider the positive range  $0 < \tau \neq 1$  in the remainder of the Letter. It is easy to prove that the mutual information of Alice and Bob has the asymptotic expression  $\lim_{\mu} I(\alpha:\beta) = \log(\mu/\eta)$ , where

$$\eta := \frac{1}{\tau} [1 + \tau^2 + (1 - \tau)^2 w^2 + \tau\theta + |1 - \tau|w(\tau\theta_A + \theta_B)]^{1/2}.$$

The latter quantity  $\eta$  represents the *total noise* affecting the quantum communication. It depends on the two invariants  $\{\tau, w\}$  plus the three noninvariant parameters  $\{\theta, \theta_A, \theta_B\}$  coming from  $\{\mathcal{U}_A, \mathcal{U}_B\}$ . Let us now bound the Holevo information  $I(\gamma:E)$  of Eve. In direct reconciliation,  $I(\alpha:E)$  can be bounded using the condition  $\theta_A \geq 2$  [16], while, in reverse reconciliation,  $I(\beta:E)$  can be bounded by the quantum mutual information. As a consequence, we get the following bound on the secret-key rate  $R_\infty \geq B_\infty := \max\{0, B_\infty(\alpha), B_\infty(\beta)\}$ , where

$$B_\infty(\alpha) = \log\left(\frac{2}{e|1 - \tau|\eta}\right) - g(w) + g(\tau + |1 - \tau|w), \quad (3)$$

and



$$B_\infty(\beta) = \log\left(\frac{2}{e|1 - \tau|\tau\eta}\right) - g(w), \quad (4)$$

with  $g(x) := [(x + 1)/2] \log[(x + 1)/2] - [(x - 1)/2] \times \log[(x - 1)/2]$ . Notice that these asymptotic rates depend only on the three parameters  $\{\tau, w, \eta\}$ . In other words, the significant information about the Gaussian attack  $G$  is fully contained in the triplet  $\{\tau, w, \eta\}$ , where  $\tau$  and  $w$  are symplectic invariants of the channel, while  $\eta$  includes the noninvariant effect of the input-output unitaries  $\{\mathcal{U}_A, \mathcal{U}_B\}$ . Such a triplet is completely known to the honest users thanks to the tomography of the channel; therefore, the corresponding value of  $B_\infty$  can be easily derived.

It is now interesting to analyze the performances of the canonical attacks in terms of the asymptotic rate  $B_\infty$ . It is easy to show that, for fixed invariants  $\tau$  and  $w$ , canonical attacks are the less perturbative and less powerful attacks. In fact, for a canonical attack, we have  $\theta = \theta_A = \theta_B = 2$ , so that the total noise  $\eta$  takes the minimum value

$$\eta = 1 + \frac{1}{\tau} + \frac{|1 - \tau|}{\tau} w := \eta_c(\tau, w). \quad (5)$$

Then, since  $B_\infty$  is monotonic in  $\eta$  [according to Eqs. (3) and (4)], the minimization of  $\eta$  is equivalent to the maximization of  $B_\infty$  (for fixed  $\tau$  and  $w$ ). By contrast, we can easily prove that the canonical attacks are the most powerful Gaussian attacks for fixed transmission  $\tau$  and total noise  $\eta$ . In other words, for every Gaussian attack, with triplet  $\{\tau, w, \eta\}$ , there always exists a canonical attack, with triplet  $\{\tau, w', \eta\}$ , such that  $B_\infty(\tau, w', \eta) \leq B_\infty(\tau, w, \eta)$ . The proof is very easy. The noise  $\eta$  of an arbitrary Gaussian attack  $G$  with  $\{\tau, w, \eta\}$  is minimized by the noise  $\eta_c(\tau, w)$  of a canonical attack  $C$  with  $\{\tau, w, \eta_c(\tau, w)\}$ . Now, let us increase  $w$  while keeping  $\tau$  fixed in  $\{\tau, w, \eta_c(\tau, w)\}$ . From Eq. (5), we see that  $\eta_c(\tau, w)$  increases in  $w$ , and, therefore, we can choose a value  $w' \geq w$  such that  $\eta_c(\tau, w') = \eta$ . Then, we get a new canonical attack  $C'$  with triplet  $\{\tau, w', \eta\}$ . But now, also the two quantities  $g(w)$  and  $g(w) - g(\tau + |1 - \tau|w)$  are increasing in  $w$ . Therefore, for fixed  $\tau$  and  $\eta$ , the condition  $w' \geq w$  minimizes the rates of Eqs. (3) and (4), which concludes the proof. By combining the previous results on the asymptotic rate  $B_\infty(\tau, w, \eta)$ , we deduce that canonical attacks can be seen as extremal Gaussian attacks, since they provide upper bounds for fixed  $\{\tau, w\}$  and lower bounds for fixed  $\{\tau, \eta\}$ .

In conclusion, we have given a simple and compact description of a completely general collective Gaussian attack. Using such a characterization, we have derived the asymptotic secret-key rates that are reachable by a protocol using coherent states, joint measurements of the

quadratures, and one-way classical communications. In particular, the secret-key rates can be bounded by relatively simple quantities depending on three channel parameters only. In terms of these bounds, a particular class of attacks (canonical attacks) can be considered as extremal. Finally, this work paves the way for completely general security analyses of cvQKD protocols, where explicit derivations of secret-key rates can be made without any assumptions on the eavesdropper's interaction.

We thank F. Caruso, V. Giovannetti, and A. Holevo for helpful comments. S.P. was supported by a Marie Curie Action within the 6th European Community Framework Programme. S.L. was supported by the W.M. Keck center for extreme quantum information theory (xQIT).

- 
- [1] S.L. Braunstein and A.K. Pati, *Quantum Information Theory with Continuous-Variables* (Kluwer Academic, Dordrecht, 2003).
  - [2] J. Eisert and M. B. Plenio, *Int. J. Quantum. Inform.* **1**, 479 (2003).
  - [3] A. S. Holevo, *Probl. Inf. Transm.* **43**, 1 (2007).
  - [4] F. Caruso *et al.*, *New J. Phys.* **8**, 310 (2006).
  - [5] M. Navascués *et al.*, *Phys. Rev. Lett.* **97**, 190502 (2006); R. García-Patrón and N.J. Cerf, *Phys. Rev. Lett.* **97**, 190503 (2006).
  - [6] R. Renner and J.I. Cirac, arXiv:0809.2243.
  - [7] C. Weedbrook *et al.*, *Phys. Rev. Lett.* **93**, 170504 (2004); A. M. Lance *et al.*, *Phys. Rev. Lett.* **95**, 180503 (2005).
  - [8] In particular,  $\mathbf{N}$  and  $\mathbf{T}$  must satisfy the properties  $\mathbf{N}^T = \mathbf{N} > 0$  and  $\det \mathbf{N} \geq (\det \mathbf{T} - 1)^2$ .
  - [9] In particular,  $\bar{n} = (\det \mathbf{N})^{1/2}$  for  $\tau = 1$ , while  $\bar{n} = [|1 - \tau|^{-1}(\det \mathbf{N})^{1/2} - 1]/2$  for  $\tau \neq 1$ .
  - [10] In particular, class  $C$  describes an attenuator for  $0 < \tau < 1$  and an amplifier for  $\tau > 1$ . Class  $B_2$  includes the ideal channel for  $r = 0$ . See Refs. [3,4] for a physical interpretation of all the classes.
  - [11] W.F. Stinespring, *Proc. Am. Math. Soc.* **6**, 211 (1955).
  - [12] For  $\tau \neq 1$ , one always has  $\mathbf{L}(\tau, r) = \mathbf{M}(\tau, r) \oplus \mathbf{I}_{E_2}$ , where the expressions of  $\mathbf{M}(\tau, r)$  can be found in Ref. [4] but in different shot-noise units. For  $\tau = 1$  (additive classical-noise channel), the decomposition of  $\mathbf{L}(1, r)$  heavily depends on the rank  $r$ . In fact, one has  $\mathbf{L}(1, 0) = \mathbf{I}$ ,  $\mathbf{L}(1, 1) = \mathbf{M}(1, 1) \oplus \mathbf{I}_{E_2}$ , and an irreducible  $\mathbf{L}(1, 2)$ .
  - [13] N.J. Cerf *et al.*, *Phys. Rev. Lett.* **85**, 1754 (2000).
  - [14] F. Grosshans *et al.*, *Nature (London)* **421**, 238 (2003); F. Grosshans, *Phys. Rev. Lett.* **94**, 020504 (2005); M. Navascués and A. Acín, *ibid.* **94**, 020505 (2005).
  - [15] Results can be then extended to an infinite box.
  - [16] Detailed derivations will be presented elsewhere.
  - [17] See, e.g., Theorem 8.4.1 in T.M. Cover, and J.A. Thomas, *Elements of Information Theory* (Wiley, New York, 2006).