

Minimum energy dissipation required for a logically irreversible operationNaoki Takeuchi^{1,2,*} and Nobuyuki Yoshikawa^{1,3}¹*Institute of Advanced Sciences, Yokohama National University, 79-5 Tokiwadai, Hodogaya, Yokohama 240-8501, Japan*²*PRESTO, Japan Science and Technology Agency, 4-1-8 Honcho, Kawaguchi, Saitama 332-0012, Japan*³*Department of Electrical and Computer Engineering, Yokohama National University, 79-5 Tokiwadai, Hodogaya, Yokohama 240-8501, Japan*

(Received 31 July 2017; published 18 January 2018)

According to Landauer's principle, the minimum heat emission required for computing is linked to logical entropy, or logical reversibility. The validity of Landauer's principle has been investigated for several decades and was finally demonstrated in recent experiments by showing that the minimum heat emission is associated with the reduction in logical entropy during a logically irreversible operation. Although the relationship between minimum heat emission and logical reversibility is being revealed, it is not clear how much free energy is required to be dissipated for a logically irreversible operation. In the present study, in order to reveal the connection between logical reversibility and free energy dissipation, we numerically demonstrated logically irreversible protocols using adiabatic superconductor logic. The calculation results of work during the protocol showed that, while the minimum heat emission conforms to Landauer's principle, the free energy dissipation can be arbitrarily reduced by performing the protocol quasistatically. The above results show that logical reversibility is not associated with thermodynamic reversibility, and that heat is not only emitted from logic devices but also absorbed by logic devices. We also formulated the heat emission from adiabatic superconductor logic during a logically irreversible operation at a finite operation speed.

DOI: [10.1103/PhysRevE.97.012124](https://doi.org/10.1103/PhysRevE.97.012124)**I. INTRODUCTION**

Understanding the thermodynamic connection between energy and computing is crucial for future computer design, because the minimum heat emission in computing is predicted to be linked to the entropy of logic devices by Landauer's principle [1]. According to Landauer's principle, the entropy of a logic device is associated with its logical entropy and thus $\Delta S = \Delta H$, where ΔS is the change of the entropy, and ΔH is the change of the logical entropy or the Shannon entropy [2] regarding the probability distribution of logic states. Therefore, the minimum heat emission during an irreversible logic operation is expected to be given by the Landauer bound or $-k_B T \Delta H$, where k_B is the Boltzmann constant and T is temperature. Numerous studies investigated the physical limits in computing based on Landauer's principle [3–8], and the validity of Landauer's principle has been investigated and discussed extensively [9–14]. Recent precise experiments using Brownian particles [11,12] clearly demonstrated that a logically irreversible operation with $\Delta H = -\ln 2$ induces a heat emission larger than $k_B T \ln 2$ in accordance with Landauer's principle. Although the relationship between minimum heat emission and logical reversibility is being revealed, it is not clear how much free energy is required to be dissipated for a logically irreversible operation and if logical reversibility is associated with thermodynamic reversibility. Theoretically, a logically irreversible operation can be performed without dissipation [15,16]. However, in conventional logic such as

complementary metal-oxide semiconductor (CMOS), switching events are always far from equilibrium and dissipative due to its operation principle [7]. Therefore, it is worth investigating if a logically irreversible operation can be performed without free energy dissipation using a practical logic device.

In the present study, numerical calculations using superconductor logic devices are performed in order to reveal the minimum free energy dissipation required for a logically irreversible operation. We first demonstrate a restore-to-one (RT1) protocol [1], which is a typical logically irreversible operation, and discuss the minimum heat emission during the protocol via a numerical calculation of the work performed on the superconductor devices by power supplies. Followed by some modification to the RT1 protocol, we then investigate the minimum free energy dissipation for a logically irreversible operation. The calculation results reveal that, while the minimum heat emission during a logically irreversible operation conforms to the Landauer bound, the free energy dissipation during a logically irreversible operation can be arbitrarily reduced. This is a circuit-level demonstration revealing the difference between logical and thermodynamic reversibility.

II. RESTORE-TO-ONE (RT1) OPERATION

For the numerical calculation, we use adiabatic quantum flux parametron (AQFP) [17], which is an adiabatic superconductor logic based on quantum flux parametron (QFP) [18]. The switching energy of a single AQFP gate can be arbitrarily reduced [19] via adiabatic switching [20,21], in which the potential energy of the gate evolves gradually between a single-well shape and a double-well shape through

*takeuchi-naoki-kx@ynu.jp

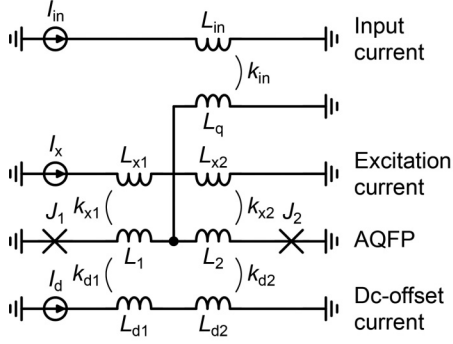

FIG. 1. Schematic of the AQFP circuit used for numerical calculation. $L_1 = L_2 = 6.58$ pH, $L_q = 26.3$ pH. The critical currents of J_1 and J_2 are $I_c = 10$ μ A. Since typical AQFP gates are designed symmetrically, $L_1 = L_2 = L$, $L_{x1} = L_{x2} = L_x$, and $L_{d1} = L_{d2} = L_d$. I_d decides the initial potential energy shape. I_x evolves the potential energy shape between a single well and a double well. I_{in} determines to which logic state the gate switches.

using ac excitation currents. The operation principle of AQFP logic is described in detail in previous works [17,19]. In the present study, we investigate the minimum energy dissipation required for a logically irreversible operation by introducing stochastic processes into an AQFP gate. Figure 1 shows the schematic of the AQFP circuit used in the numerical calculation, the circuit parameters of which are described in the caption. The device parameters, such as a subgap resistance, are based on the AIST high-speed standard process (HSTP) [22]. Here we briefly explain how the circuit works. An AQFP gate is composed of the inductors, L_1 , L_2 , and L_q , and the Josephson junctions, J_1 and J_2 . The input flux, $\Phi_{in} = k_{in}(L_{in}L_q)^{0.5}I_{in}$, decides to which logic state the gate switches. The dc-offset flux, $\Phi_d = k_{d1}(L_{d1}L_1)^{0.5}I_d + k_{d2}(L_{d2}L_2)^{0.5}I_d = 2k_d(L_dL)^{0.5}I_d$, decides the initial potential energy shape, where we assumed that $k_d = k_{d1} = k_{d2}$, $L_d = L_{d1} = L_{d2}$, and $L = L_1 = L_2$. The excitation flux, $\Phi_x = k_{x1}(L_{x1}L_1)^{0.5}I_x + k_{x2}(L_{x2}L_2)^{0.5}I_x = 2k_x(L_xL)^{0.5}I_x$, evolves the potential energy shape between a single well and a double well, where we assumed that $L_x = L_{x1} = L_{x2}$. For $\Phi_d = 0$ ($\Phi_d = \pm\Phi_0$), the initial potential energy shape is a single well (a double well), and the potential energy evolves into a double-well shape (a single-well shape) by increasing Φ_x from 0 to Φ_0 , where $\Phi_0 = h/2e$ is a single flux quantum, h is the Planck constant, and e is the elementary charge. The detailed relationship between potential energy shapes and applied magnetic fluxes is given in the literature [23]. For $\Phi_{in} > 0$ ($\Phi_{in} < 0$), the AQFP gate switches into logic 1 (logic 0) while the potential energy evolves from a single-well shape into a double-well shape. It is noteworthy that, for $\Phi_{in} = 0$, the AQFP gate stochastically switches to either logic 0 or logic 1, because the shape of the potential energy changes symmetrically, which indicates the ease of introducing stochastic processes into an AQFP gate.

Through using the circuit shown in Fig. 1, we perform an RT1 operation, which is a typical logically irreversible operation in information thermodynamic studies [9–14]. Figure 2 shows the protocol to perform an RT1 operation using the AQFP gate with a dc-offset flux of $\Phi_d = -\Phi_0$. Figure 2(a) describes the evolution of the potential energy

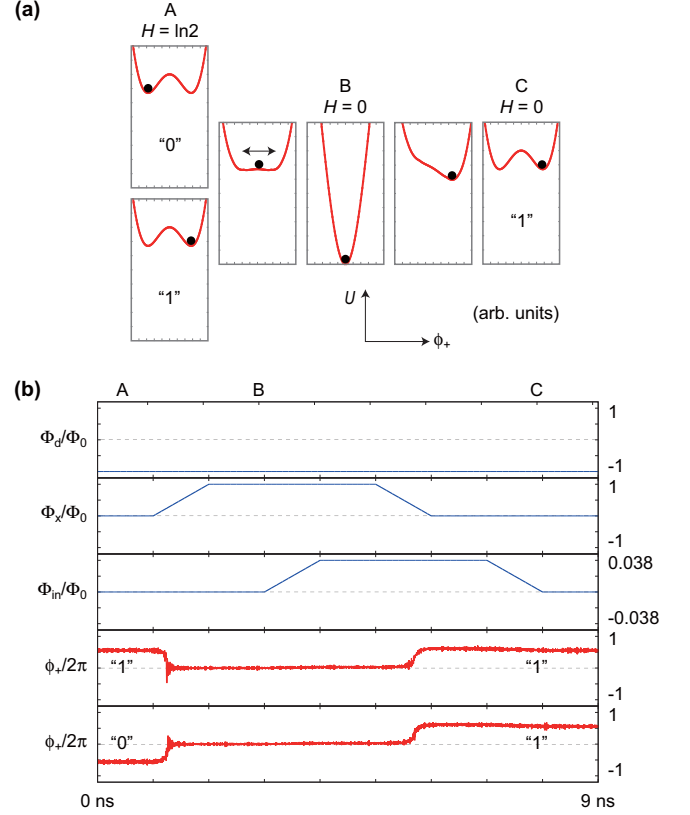

FIG. 2. RT1 protocol. (a) Evolution of the potential energy of the AQFP gate. (b) Waveforms of the AQFP gate. At the initial stage (A), the logical entropy of the AQFP gate, H , is $\ln 2$, because the probability of being in logic 1 is equal to that of being in logic 0. Through forming a single-well potential in stage B, H reduces to 0 in the final stage (C). This protocol is logically irreversible due to the reduction in logical entropy.

of the AQFP gate during the protocol, which was obtained using the equation reported by Ko and Lee [24]. The potential energy, U , is a function of ϕ_+ , where $\phi_+ = \phi_1 + \phi_2$, and ϕ_1 and ϕ_2 are the phase differences of the Josephson junctions, J_1 and J_2 , respectively. Figure 2(b) shows the waveforms during the protocol at 4.2 K, which was obtained using the Josephson circuit simulator, JSIM_n [25]. ϕ_+ represents the logic state of the AQFP gate; positive ϕ_+ represents logic 1 and negative ϕ_+ represents logic 0. At the initial stage (A), the shape of the potential energy is a double well due to $\Phi_d = -\Phi_0$ but the logic state is stochastically determined, because no input flux is applied ($\Phi_{in} = 0$). Therefore, the logical entropy of the AQFP gate at stage A is given by $H = \ln 2$, because the probability of being in logic 0 is the same as that of being in logic 1. After stage A, Φ_x increases and the potential energy evolves from a double-well shape into a single-well shape at stage B. Followed by increasing Φ_{in} to approximately $0.038\Phi_0$ during stages B and C, Φ_x returns to zero and the AQFP gate switches to logic 1 at stage C due to $\Phi_{in} > 0$. As a result, whether the initial logic state is 0 or 1 (A), the final logic state (C) is fixed to 1, which indicates the reduction in logical entropy from $\ln 2$ to 0. The RT1 operation is logically irreversible [26], because it is not possible to determine the initial logic state (A) after reaching the final state (C) due to the reduction in logical

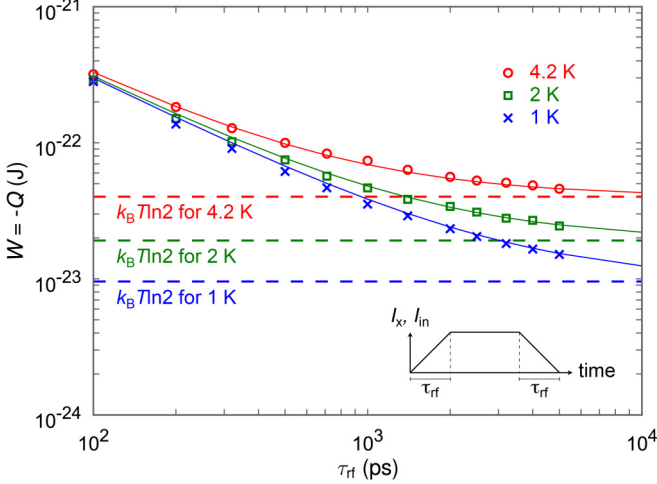

FIG. 3. Numerical calculation results of the average heat emission, $-Q$, during the RT1 protocol. $-Q$ was calculated over 2000 iterations of the protocol at three different temperatures: 4.2, 2, and 1 K. The fitting curves are $-Q = 2.89 \times 10^{-32} / \tau_{\text{rf}} + k_{\text{B}} T \ln 2$. As the rise and fall time of the excitation and input currents, τ_{rf} , increases, the average heat emission decreases and asymptotically approaches $k_{\text{B}} T \ln 2$ in accordance with Landauer's principle.

entropy. According to Landauer's principle, the minimum heat emission during the RT1 operation equals $k_{\text{B}} T \ln 2$ so that the total entropy of the relevant system does not decrease.

III. HEAT EMISSION REQUIRED FOR A LOGICALLY IRREVERSIBLE OPERATION

In this section, we calculate the heat emission during the RT1 protocol to confirm if the Landauer bound ($k_{\text{B}} T \ln 2$) appears in the AQFP gate. First we discuss how to calculate heat emission. Let E be the average energy of the AQFP gate, let W be the average work performed on the AQFP gate by the power supplies, which generate I_x and I_{in} , and let Q be the average heat absorbed by the AQFP gate from the thermal bath. According to the first law of thermodynamics, the change in E is given by $\Delta E = W + Q$. In the RT1 protocol, the energy of the initial state (A) is the same as that of the final state (C), and therefore $\Delta E = 0$ between the initial and final states. As a result, $-Q = W$ is obtained, which shows that the average heat emission ($-Q$) from the AQFP gate during the RT1 protocol is directly obtained by calculating the average work (W) performed on the AQFP gate by the power supplies (I_x and I_{in}) during the protocol. We calculate the work by using JSIM_n. The work performed by I_x (I_{in}) is obtained by integrating the product of I_x (I_{in}) and voltages across L_{x1} and L_{x2} (L_{in}) over time [27]. Note that I_d is dc and thus does not perform work during the protocol. In the numerical calculation using JSIM_n, thermal noise current sources are added in parallel to the Josephson junctions [28], the amplitude of which is given by the Monte Carlo method and follows the Gaussian law with the standard deviation given by $(2k_{\text{B}} T / R_{\text{sg}} \Delta t)^{0.5}$, where Δt is a simulation time step, and R_{sg} is the subgap resistance. In the present study, $\Delta t = 0.2$ ps, $R_{\text{sg}} = 1000 \Omega$. Figure 3 shows the calculation results of the average work (W) or average heat emission ($-Q$) as a function of the rise and fall

time of the excitation and input currents, τ_{rf} , at three different temperatures: 4.2 K, which is a typical operation temperature for AQFP, 2 K, and 1 K. W was calculated over 2000 iterations of the RT1 protocol (A–C in Fig. 2) at each temperature. The figure shows that, as τ_{rf} increases and the RT1 protocol is performed more slowly, $-Q$ decreases and asymptotically approaches $k_{\text{B}} T \ln 2$ at all temperatures, which agrees well with Landauer's principle and studies related to it [11, 12, 14]. The above results clearly indicate that the entropy of an AQFP gate is associated with its logical entropy, or $\Delta S = \Delta H$.

IV. FREE ENERGY DISSIPATION REQUIRED FOR A LOGICALLY IRREVERSIBLE OPERATION

In this section, we investigate the minimum free energy dissipation during an RT1 operation, in order to see if a logically irreversible operation (RT1) can be performed in a thermodynamically reversible manner. If logical reversibility is tied to thermodynamic reversibility, an RT1 operation determines a nonzero minimum energy dissipation, as well as the minimum heat emission of $k_{\text{B}} T \ln 2$. First, we discuss how to calculate free energy dissipation. Dissipated free energy or work is given by [29]

$$F_{\text{diss}} = W - \Delta F, \quad (1)$$

where ΔF is the change in the free energy of the AQFP gate. We assume a protocol, in which the initial and the final states of the AQFP gate are the same in terms of energy and entropy. For this protocol, ΔF is zero and thus Eq. (1) becomes

$$F_{\text{diss}} = W, \quad (2)$$

which shows that free energy dissipation can be directly obtained by calculating average work, if the initial and the final states of the AQFP gate are the same. In other words, in the RT1 protocol shown in Fig. 2, it is not possible to obtain free energy dissipation from the calculation of work, because the initial and final logical entropy are different. In order to calculate the minimum free energy dissipation during an RT1 operation, we modify the RT1 protocol so that the initial and the final states are the same. Figure 4 shows the modified RT1 protocol with $\Phi_d = 0$. At stage A, the potential energy shape is a single well due to $\Phi_d = 0$. During stages A and B, Φ_x increases and the potential energy evolves from a single-well shape into a double-well shape. Since no input flux is applied ($\Phi_{\text{in}} = 0$), the AQFP gate stochastically switches to either logic 0 or 1 at stage B ($H = \ln 2$). Between stages B and D, an RT1 operation is performed in a way similar to the procedure shown in Fig. 2. At stage E, Φ_x returns to zero and potential energy shape returns to a single well. In the modified protocol, the initial (A) and the final (E) states are the same and an RT1 operation is included between stages B and D. Figure 5 shows the calculation results of the average work (W) or free energy dissipation (F_{diss}) as a function of τ_{rf} at three different temperatures: 4.2, 2, and 1 K. W was calculated over 2000 iterations of the modified RT1 protocol (A to E in Fig. 4) at each temperature. The figure shows that, unlike the calculation results shown in Fig. 3, F_{diss} decreases without energy bounds at all temperatures, which indicates that free energy dissipation or the total entropy production of the relevant system including the AQFP gate and the thermal bath

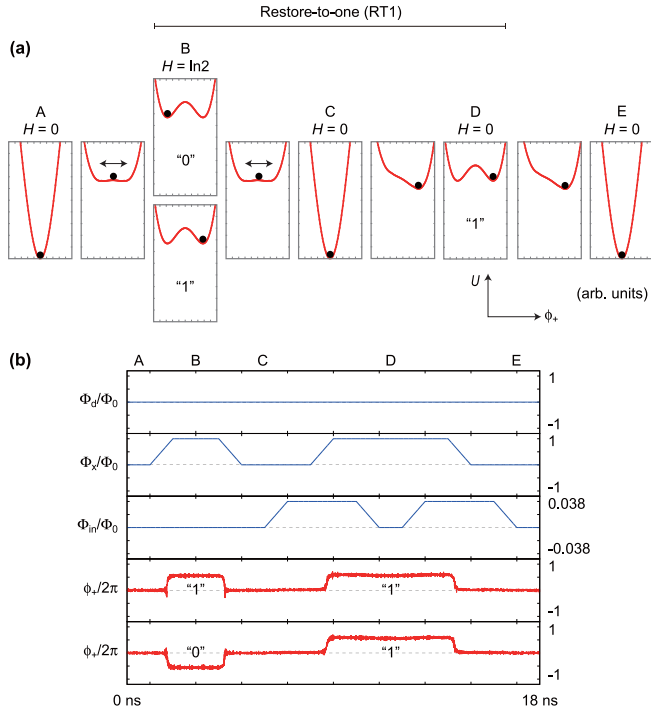

FIG. 4. Modified RT1 protocol. (a) Evolution of the potential energy of the AQFP gate. (b) Waveforms of the AQFP gate. The initial state of the AQFP gate at stage A is the same as the final state at stage E. An RT1 operation is performed between stages B and D.

is zero in the quasistatic limit. In other words, the modified protocol can be performed in a thermodynamically reversible manner due to the conservation of the total entropy of the relevant system, even if a logically irreversible operation (RT1) is included. This demonstrates that a logically irreversible operation can be performed in a thermodynamically reversible manner, and that logical reversibility is not associated with thermodynamic reversibility, as recent theoretical studies sug-

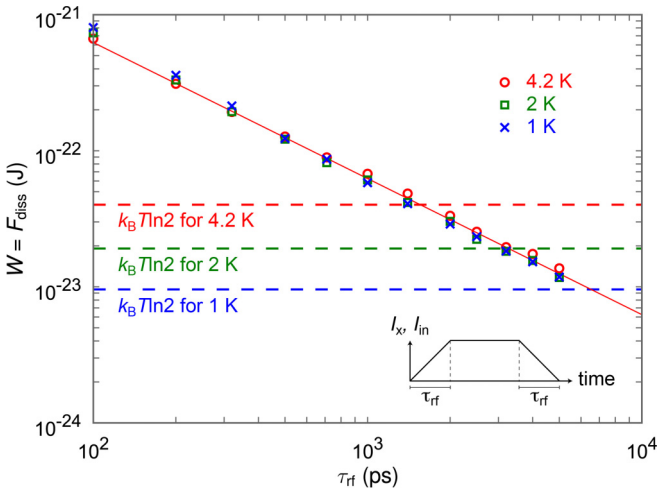

FIG. 5. Numerical calculation results of the free energy dissipation, F_{diss} , during the modified RT1 protocol. F_{diss} was calculated over 2000 iterations of the modified protocol at three different temperatures: 4.2, 2, and 1 K. The fitting curve is $F_{\text{diss}} = 6.25 \times 10^{-32} / \tau_{\text{rf}}$. As τ_{rf} increases, the energy dissipation decreases without energy bounds.

gested [15,16]. In fact, both the protocols shown in Figs. 2 and 4 are considered to be thermodynamically reversible from the viewpoint of time reversibility [15,16,29–32]; the probability distribution of the logic state at each stage is the same, even if we perform the protocols in a time-reversal way. Moreover, the above calculation results show that heat is not only emitted ($-Q = k_B T \ln 2$) from the AQFP gate during an RT1 operation ($\Delta H = -\ln 2$) but also absorbed ($Q = k_B T \ln 2$) by the AQFP gate during stages A and B ($\Delta H = \ln 2$).

From the fitting curves shown in Figs. 3 and 5, one can derive an equation regarding the heat emission during an RT1 operation as follows:

$$-Q = \frac{\Theta}{\tau_{\text{rf}}} - k_B T \Delta H, \quad (3)$$

where the first term on the right-hand side represents free energy dissipation, the second term on the right-hand side represents the heat due to logical entropy change, and Θ is the energy-delay product (EDP) of the system, which is independent of temperature. In AQFP logic, the energy scale is given by $I_c \Phi_0$, and the time scale is given by $\Phi_0 / I_c R_{\text{sg}}$ [33], where R_{sg} is the subgap resistance and shows the damping condition of Josephson junctions, and hence the EDP of an AQFP gate should be proportional to $I_c \Phi_0^2 / I_c R_{\text{sg}}$. By using the fitting curves shown in Fig. 3 and the device parameters: $I_c = 10 \mu\text{A}$ and $I_c R_{\text{sg}} = 10 \text{mV}$, the EDP of an AQFP gate during an RT1 operation is determined as follows:

$$\Theta \approx 6.7 \frac{I_c \Phi_0^2}{(I_c R_{\text{sg}})}. \quad (4)$$

Equations (3) and (4) formulate the heat emission from an AQFP gate during an RT1 operation.

V. CONCLUSION

We numerically performed two types of protocols using adiabatic superconductor logic in order to calculate both the minimum heat emission and the minimum energy dissipation required for a logically irreversible operation. Via the RT1 protocol, which is a logically irreversible operation accompanied by a reduction in logical entropy of $\ln 2$, the heat emission from the AQFP gate into the thermal bath was calculated from the work performed on the AQFP gate by power supplies. The calculation results showed that the minimum heat emission during an RT1 operation equals $k_B T \ln 2$ in accordance with Landauer's principle, which indicates that logical entropy is associated with entropy. Via the modified RT1 protocol, where the initial and final states of the AQFP gate are the same and an RT1 operation is performed in the middle of the modified protocol, free energy dissipation was calculated from the work. It was found that the energy dissipation decreases without energy bounds as the modified protocol is performed more slowly, which indicates that a logically irreversible operation can be performed in a thermodynamically reversible manner and that logical reversibility is not associated with thermodynamic reversibility. Based on the above numerical calculation results, we also formulated the heat emission from the AQFP gate during an RT1 operation.

ACKNOWLEDGMENTS

The present study was supported by a Grant-in-Aid for Scientific Research (S) (Grant No. 26220904) from the Japan

Society for the Promotion of Science (JSPS), PRESTO of the Japan Science and Technology Agency (JST) (Grant No. JPMJPR1528), and the MEXT Program for Promoting the Reform of National Universities.

- [1] R. Landauer, Irreversibility and heat generation in the computing process, *IBM J. Res. Dev.* **5**, 183 (1961).
- [2] C. E. Shannon, A mathematical theory of communication, *Bell Syst. Tech. J.* **27**, 623 (1948).
- [3] R. W. Keyes, Fundamental limits in digital information processing, *Proc. IEEE* **69**, 267 (1981).
- [4] C. H. Bennett, The thermodynamics of computation—a review, *Int. J. Theor. Phys.* **21**, 905 (1982).
- [5] J. D. Meindl and J. A. Davis, The fundamental limit on binary switching energy for terascale integration (TSI), *IEEE J. Solid-State Circuits* **35**, 1515 (2000).
- [6] S. Lloyd, Ultimate physical limits to computation, *Nature* **406**, 1047 (2000).
- [7] V. V. Zhirnov, R. K. Cavin, J. A. Hutchby, and G. I. Bourianoff, Limits to binary logic switch scaling—a gedanken model, *Proc. IEEE* **9**, 1934 (2003).
- [8] I. L. Markov, Limits on fundamental limits to computation, *Nature* **512**, 147 (2014).
- [9] K. Shizume, Heat generation required by information erasure, *Phys. Rev. E* **52**, 3495 (1995).
- [10] A. O. Orlov, C. S. Lent, C. C. Thorpe, G. P. Boechler, and G. L. Snider, Experimental test of Landauer’s principle at the sub- $k_B T$ level, *Jpn. J. Appl. Phys.* **51**, 06FE10 (2012).
- [11] A. Bérut, A. Arakelyan, A. Petrosyan, S. Ciliberto, R. Dillenschneider, and E. Lutz, Experimental verification of Landauer’s principle linking information and thermodynamics, *Nature* **483**, 187 (2012).
- [12] Y. Jun, M. Gavrilov, and J. Bechhoefer, High-Precision Test of Landauer’s Principle in a Feedback Trap, *Phys. Rev. Lett.* **113**, 190601 (2014).
- [13] L. Martini, M. Pancaldi, M. Madami, P. Vavassori, G. Gubbiotti, S. Tacchi, F. Hartmann, M. Emmerling, S. Höfling, L. Worschech, and G. Carloti, Experimental and theoretical analysis of Landauer erasure in nano-magnetic switches of different sizes, *Nano Energy* **19**, 108 (2016).
- [14] J. Hong, B. Lambson, S. Dhuey, and J. Bokor, Experimental test of Landauer’s principle in single-bit operations on nanomagnetic memory bits, *Sci. Adv.* **2**, e1501492 (2016).
- [15] T. Sagawa, Thermodynamic and logical reversibilities revisited, *J. Stat. Mech. Theory Exp.* (2014) P03025.
- [16] J. M. R. Parrondo, J. M. Horowitz, and T. Sagawa, Thermodynamics of information, *Nat. Phys.* **11**, 131 (2015).
- [17] N. Takeuchi, D. Ozawa, Y. Yamanashi, and N. Yoshikawa, An adiabatic quantum flux parametron as an ultra-low-power logic device, *Supercond. Sci. Technol.* **26**, 035010 (2013).
- [18] M. Hosoya, W. Hioe, J. Casas, R. Kamikawai, Y. Harada, Y. Wada, H. Nakane, R. Suda, and E. Goto, Quantum flux parametron: a single quantum flux device for Josephson supercomputer, *IEEE Trans. Appl. Supercond.* **1**, 77 (1991).
- [19] N. Takeuchi, Y. Yamanashi, and N. Yoshikawa, Thermodynamic Study of Energy Dissipation in Adiabatic Superconductor Logic, *Phys. Rev. Appl.* **4**, 034007 (2015).
- [20] K. Likharev, Dynamics of some single flux quantum devices: I. Parametric quantron, *IEEE Trans. Magn.* **13**, 242 (1977).
- [21] J. G. Koller and W. C. Athas, Adiabatic switching, low energy computing, and the physics of storing and erasing information, in *Proceedings of Workshop on Physics and Computing, 1992* (IEEE, New York, 1992), pp. 267–270.
- [22] N. Takeuchi, S. Nagasawa, F. China, T. Ando, M. Hidaka, Y. Yamanashi, and N. Yoshikawa, Adiabatic quantum-flux-parametron cell library designed using a 10 kA cm^{-2} niobium fabrication process, *Supercond. Sci. Technol.* **30**, 035002 (2017).
- [23] K. Fang, N. Takeuchi, T. Ando, Y. Yamanashi, and N. Yoshikawa, Multi-excitation adiabatic quantum-flux-parametron, *J. Appl. Phys.* **121**, 143901 (2017).
- [24] H. L. Ko and G. S. Lee, Noise analysis of the quantum flux parametron, *IEEE Trans. Appl. Supercond.* **2**, 156 (1992).
- [25] S. R. Whiteley, Josephson junctions in SPICE3, *IEEE Trans. Magn.* **27**, 2902 (1991).
- [26] C. H. Bennett, Logical reversibility of computation, *IBM J. Res. Dev.* **17**, 525 (1973).
- [27] N. Takeuchi, Y. Yamanashi, and N. Yoshikawa, Measurement of 10 zJ energy dissipation of adiabatic quantum-flux-parametron logic using a superconducting resonator, *Appl. Phys. Lett.* **102**, 052602 (2013).
- [28] M. Jeffery, P. Y. Xie, S. R. Whiteley, and T. Van Duzer, Monte Carlo and thermal noise analysis of ultra-high-speed high temperature superconductor digital circuits, *IEEE Trans. Appl. Supercond.* **9**, 4095 (1999).
- [29] C. Jarzynski, Nonequilibrium Equality for Free Energy Differences, *Phys. Rev. Lett.* **78**, 2690 (1997).
- [30] G. E. Crooks, Entropy production fluctuation theorem and the nonequilibrium work relation for free energy differences, *Phys. Rev. E* **60**, 2721 (1999).
- [31] C. Jarzynski, Hamiltonian derivation of a detailed fluctuation theorem, *J. Stat. Phys.* **98**, 77 (2000).
- [32] G. E. Crooks, On thermodynamic and microscopic reversibility, *J. Stat. Mech. Theory Exp.* (2011) P07008.
- [33] N. Takeuchi, Y. Yamanashi, and N. Yoshikawa, Energy efficiency of adiabatic superconductor logic, *Supercond. Sci. Technol.* **28**, 015003 (2015).