

Full reduction of large finite random Ising systems by real space renormalization group

Avisay Efrat and Moshe Schwartz

Raymond and Beverly Sackler Faculty of Exact Sciences, School of Physics and Astronomy, Tel Aviv University, Ramat Aviv, Tel Aviv 69978, Israel

(Received 3 January 2003; published 18 August 2003)

We describe how to evaluate approximately various physical interesting quantities in random Ising systems by direct renormalization of a finite system. The renormalization procedure is used to reduce the number of degrees of freedom to a number that is small enough, enabling direct summing over the surviving spins. This procedure can be used to obtain averages of functions of the surviving spins. We show how to evaluate averages that involve spins that do not survive the renormalization procedure. We show, for the random field Ising model, how to obtain $\overline{\Gamma}(\vec{r}) = \langle \sigma(0)\sigma(\vec{r}) \rangle - \langle \sigma(0) \rangle \langle \sigma(\vec{r}) \rangle$, the “connected” correlation function, and $S(\vec{r}) = \langle \sigma(0)\sigma(\vec{r}) \rangle$, the “disconnected” correlation function. Consequently, we show how to obtain the average susceptibility and the average energy. For an Ising system with random bonds and random fields, we show how to obtain the average specific heat. We conclude by presenting our numerical results for the average susceptibility and the function $\overline{\Gamma}(r)$ along one of the principal axes. (In this work, the full three-dimensional (3D) correlation is calculated and not just parameters such ν or η). The results for the average susceptibility are used to extract the critical temperature and critical exponents of the 3D random field Ising system.

DOI: 10.1103/PhysRevE.68.026114

PACS number(s): 05.50.+q, 64.60.Cn, 75.10.Nr, 75.10.Hk

I. INTRODUCTION AND OUTLINE

Real space renormalization group (RSRG) served as a major tool, over the past 30 years, in the field of critical phenomena. By simplifying calculations near a critical point, the various RSRG techniques, such as using the majority rule [1], the well known Migdal-Kadanoff (MK) [2,3], the Casher-Schwartz [4], and others [5], allow one to penetrate the critical regime to a point at which critical exponents can be extracted. For translational invariant (pure) systems, only a single renormalization step is required to obtain the recursion relations for the parameters of the Hamiltonian, from which critical fixed points may be derived along with critical exponents. For random systems, the recursion relations are position dependent. Therefore, a natural approach is to consider the recursion for the distribution of disorder. Equivalently, recursion relations may be obtained for all the parameters defining the distribution, moments, correlations, etc. Practically, in this approach, the recursion relations are truncated to obtain relations involving only the mean and variance, keeping the random couplings independent [6–9]. An alternative approach, suggested first by Berker and Ostlund [10], is to consider a given realization of disorder on a finite system. Renormalization is then used to reduce the system to a size where brute force calculation is possible. Thermal averages of certain quantities can thus be obtained for that realization and ensemble average is obtained by repeating the procedure for many realizations and averaging the results. The advantage of the method is that all the moments and correlations generated by renormalization are kept. The disadvantage is that the renormalization leaves in the end a small number of spins and, therefore, only thermal averages of functions of those spins can be evaluated directly. This is good enough to obtain directly the ensemble average of the magnetization [11], because the average magnetization obtained from the surviving spins is exactly the true average

magnetization. If, on the other hand, we are interested in averages involving spins that do not survive the renormalization process, things become much more complicated. Take, for example, the ensemble averaged correlation, $\overline{\Gamma}(r_{ij}) = \langle \sigma_i \sigma_j \rangle - \langle \sigma_i \rangle \langle \sigma_j \rangle$, where $\langle \dots \rangle$ denotes thermal average and $\overline{\dots}$ denotes ensemble average. It can be calculated directly from the remaining spins provided that the vector r_{ij} connecting the sites i and j equals a vector connecting two of the surviving spins or obtained from it by a symmetry operation on the initial lattice. In any other case, a direct calculation is impossible. It is true that quantities, such as the susceptibility that involves $\overline{\Gamma}_{ij}$'s for all pairs of sites, can be calculated indirectly [11–14]. The zero-field susceptibility is the derivative of the magnetization with respect to a uniform field H at $H=0$. This was used, by Dayan *et al.* [11], to calculate the zero-field susceptibility by RSRG. They added a uniform field H to each realization of the random field and obtained the average magnetization (as described above) as a function of H . Numerical differentiation was then employed to obtain the average susceptibility. In fact, many ensemble averages of interesting quantities may be obtained by applying this method. The trouble with this approach is that even in the relatively simple case of evaluating the susceptibility, the numerical differentiation is quite problematic. Berker and co-workers [12–14] used the chain rule to approximately recover thermodynamic densities of the original system from the renormalized couplings of the reduced system. The main problem here is that the method is limited only to the obtainment of thermal averages of products of spins showing in the Hamiltonian. The purpose of the present paper is to show how to calculate various interesting quantities that involve spins that do not survive the renormalization by a direct and effective method.

The paper is organized as follows. In Sec. II, we describe briefly the Casher-Schwartz (CS) renormalization procedure, which is the RSRG that we use here for the numerical dem-

onstration of our method in Sec. IV. Note, however, that the method we present is more general and can be used with any other renormalization procedure that involves a decimation scheme. (This includes the extensively used MK technique [2,3] but excludes schemes of the nature of the “majority rule” [1].) In Sec. III, the elements of our method are mainly considered for the random field Ising system. It is shown how to calculate the average “connected” spin-spin correlation function $\overline{\Gamma}_{ij}$ and the average “disconnected” spin-spin correlations $\overline{S}_{ij} = \langle \sigma_i \sigma_j \rangle$, from which the average susceptibility $\overline{\chi}$ and the average total energy \overline{E} can be easily obtained. It is further shown how to calculate the average specific heat \overline{C} for an Ising system with random bonds and random fields. Note that the method presented here enables a full evaluation (though approximate) of quantities such as $\overline{\Gamma}_{ij}$ and \overline{S}_{ij} that depend on distance. As we shall show later, this follows from two facts: (a) The finite and small number of spins we are left with at the end of the renormalization procedure; (b) the fact that the system is random. (It will be shown how, in principle, this method can be used to calculate, by a similar method of a finite system renormalization, such quantities in the pure system. The practicality of the method for the pure system will prove, however, to be questionable.) In the last section, we demonstrate the usefulness of our method by calculating the average susceptibility $\overline{\chi}$ and $\overline{\Gamma}(r)$ for r 's lying on a main axis of the lattice, for the random field Ising system. The evaluation of $\overline{\chi}$ is used to derive critical exponents that may be compared with the exponents derived by other methods. Note that the approximate values of the exponents, obtained in such a calculation, depend not only on the numerical application of the method presented here, but also on the specific scheme of renormalization employed.

II. RENORMALIZATION

Although our method is general, we will use the CS scheme [4] for the numerical demonstration of our method and present the results in Sec. IV. Like in any other renormalization procedure (such as MK [2,3] and others [5]), when performed on a regular lattice, recovering the original form of the Hamiltonian is not an exact procedure. Nevertheless, for the translational invariant (pure) Ising system, it produces good results [4]. In most RSRG calculations for random systems, correlations generated by the renormalization are simply ignored. It was suggested, however, many years ago by Harris and Lubensky [15] that those correlations are important. The CS scheme generates, indeed, such correlations. Schwartz and Fishman [6] used the CS scheme to renormalize the mean and variance of the distribution of random bonds. They took into account the generated correlations and found that inclusion of the effect of generated correlations in renormalized variance is essential.

The CS renormalization method for the pure Ising system is described in detail in Ref. [4], while a detailed demonstration of how it can be used, locally, for a random bond system can be found in Ref. [6]. Moreover, our numerical renormalization procedure here, as conducted for the random field

Ising model, follows almost exactly the numerical procedure used by Dayan *et al.* [11]. Here, therefore, we only describe it in brief. According to the CS scheme, an integration of every other site is performed exactly, but then, all non-nearest-neighbor bonds, generated by the RG transformation, are symmetrically bent onto available nearest-neighbor bonds; many-spin odd interactions may be grouped to form the renormalized field, while many-spin even interactions are simply omitted. Here, though, as in Ref. [11], in order to simplify computer programming, we only keep the renormalized fields and ignore the many-spin odd interactions as well. The integration of every other site is, relatively, an easy task, even in three-dimensions, since every spin situated on an even site interacts only with neighboring spins situated on odd sites.

We start then with a set of $N=L^3$ Ising spins, $\sigma_i = \pm 1$, with $L=2^n$, situated on a three-dimensional (3D) simple cubic (sc) lattice. Suppose, now, that the Ising system is not translational invariant and represented by the Hamiltonian

$$\mathcal{H} = - \sum_{\langle i,j \rangle} J_{ij} \sigma_i \sigma_j - \sum_i h_i \sigma_i, \quad (1)$$

where $\langle i,j \rangle$ refers to nearest neighbors only. Performing the trace over every other site, each of the erased spins, contributes separately to each of the terms in the new Hamiltonian, generating all possible interactions among its six nearest neighbors (nn 's). We arrive, then, at a new Hamiltonian, containing fields, nn 's, next nearest neighbors (nnn 's), and multispin interaction terms, from three-spin to six-spin interactions. All the couplings are again local. The result is even further complicated by the fact that the resulting lattice is not a sc but a face-centered cubic (fcc) lattice. As was mentioned above, the multispin interactions are simply ignored, while the values of the three generated nnn interactions are symmetrically distributed over the 12 nn interactions. To bring the lattice back to its sc form, we still need to integrate over each of the face centered spins. To do that, we first bend all nn bonds connecting between face centers, onto nn bonds that lie on the face of the cube and connecting between face-centers and vertices. The extra decimation step can now be easily executed following the CS 2D renormalization scheme. This is a much simpler procedure, which we shall not describe here, but can also be found in Refs. [4,6].

In our study, the above two-step procedure is performed locally and repeated iteratively until the system is brought down to a size of $2 \times 2 \times 2$, for which a trace can be performed exactly. The details of the calculation, to be presented in the following sections, depend on the specific scheme we use. However, the general structure of our method, presented in the following section, depends only on one feature of the CS scheme that is common to many RSRG techniques. This is the fact that the renormalized Hamiltonian depends on a small finite number of original spins. Therefore, our method is not limited to a specific scheme and will work with any decimation procedure.

III. THE METHOD

In this section, we describe, mainly, how to calculate the connected and disconnected correlation functions for the three-dimensional random field system. We consider the random field Hamiltonian

$$\mathcal{H} = -J \sum_{\langle i,j \rangle} \sigma_i \sigma_j - \sum_i h_i \sigma_i. \quad (2)$$

The h_i 's are random uncorrelated fields, distributed around zero,

$$\overline{h_i} = 0, \quad \overline{h_i h_j} = h^2 \delta_{ij}. \quad (3)$$

We assume that the random fields are distributed according to a Gaussian distribution,

$$P\{h\} = \prod_i P_i(h_i) \equiv \frac{1}{\Lambda} \exp\left(-\frac{1}{2h^2} \sum_i h_i^2\right), \quad (4)$$

where $\Lambda \equiv (h\sqrt{2\pi})^N$. We are interested in calculating the average spin-spin correlations and susceptibility of a large, but finite, system, over a large number of realizations of the random field. Consider first

$$\Gamma_{ij} \equiv \langle \sigma_i \sigma_j \rangle - \langle \sigma_i \rangle \langle \sigma_j \rangle. \quad (5)$$

The susceptibility is related to the spin-spin correlations by

$$\chi = \frac{\beta}{N} \sum_{i,j} \Gamma_{ij}. \quad (6)$$

The average susceptibility

$$\overline{\chi} = \beta \sum_j \overline{\Gamma_{ij}} \quad (7)$$

is obtained by averaging over a large enough number of realizations. The true average of Γ_{ij} depends, of course, only on the radius separating i and j . Namely, translational invariance is restored by averaging. Obviously, since we consider a large system, calculating the above quantities directly involves the impossible task of performing a trace over a large number of spins numerically. We, thus, turn to real space renormalization. By choosing first a specific renormalization scheme (CS, MK, etc.), the rescaling factor b is set. We then choose the linear size of our system, L , to be b to some integer power, $n \geq 2$. The renormalization transformation is then used locally, by performing $n-1$ repeated iterations, to fully reduce the size of the system to $b \times b \times b$. The thermal average of each of the b^3 remaining spins can now be calculated exactly by performing the trace using the Hamiltonian of the reduced system. (It is hard to see how brute force summation can be done for $b > 3$.) In fact, the averaging over large enough number of realizations, we may expect $\overline{\langle \sigma_i \rangle}$ to be translational invariant and, therefore, to be equal to the average magnetization per spin. In practice, in order to improve our averaging, we will calculate it as follows:

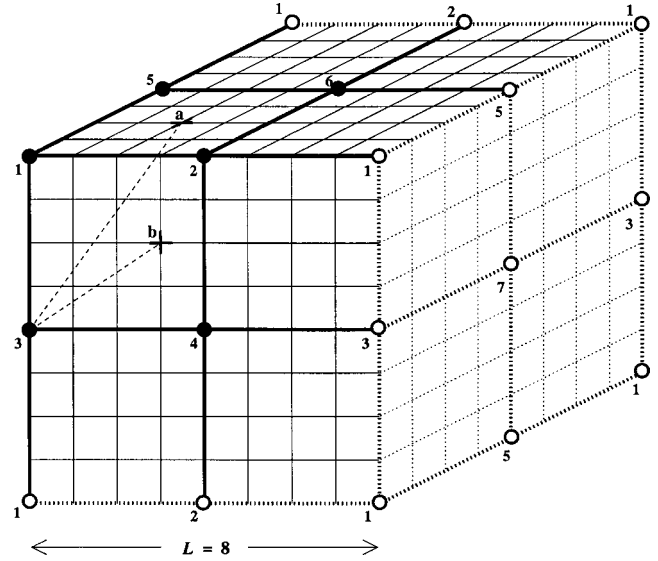

FIG. 1. Starting with a large system of linear size $L=2^n$ (here demonstrated with $n=3$), the system is fully reduced, using some RSRG transformation, to its minimal linear size of $L=2$. The black numbered dots and the thickened lines connecting them, indicate, respectively, the eight remaining sites (only six of them are shown) and the remaining bonds connecting them, of the renormalized system. The circles and the dotted lines reflect the boundary conditions imposed on the system. Sites that are nn 's in the reduced system (such as 1 and 2) are, in fact, $L/2$ lattice constants apart in the original system. From all distances available in the original system (such as $3 \leftrightarrow a$ and $3 \leftrightarrow b$), only $L/2$ for nn 's, $L/\sqrt{2}$ for nnn 's (such as $1 \leftrightarrow 4$), and $\sqrt{3}L/2$ on the main diagonals (such as $3 \leftrightarrow 6$) are available in the reduced system.

$$\overline{M} \equiv \frac{1}{N} \sum_{i=1}^N \overline{\langle \sigma_i \rangle}_{\mathcal{H}_N} = \frac{1}{8} \sum_{i=1}^8 \overline{\langle \sigma_i \rangle}_{\mathcal{H}_8}. \quad (8)$$

Although, in principle, calculating thermal averages for the renormalized eight-spin system is a reasonable task, we are now faced with a different problem. The problem is that the reduced system only carries information about the eight spins that survived the renormalization procedure. While this makes no difference when calculating quantities containing thermal averages of a single spin (such as the average magnetization above), it makes it impossible to calculate directly quantities that contain thermal averages of more than one spin. Such are the average spin-spin correlations, $\overline{\Gamma_{ij}}$ at distances other than $L/2$, $L/\sqrt{2}$, and $\sqrt{3}L/2$, and such is the average susceptibility, which, according to Eq. (7), requires the sum of Γ_{ij} over all distances available in the original system. This is simply because spins that are NN 's in the reduced system are, in fact, $L/2$ lattice constants apart in the original system (see Fig. 1). Indeed, as was done by Dayan *et al.* [11], one may calculate the susceptibility by applying a small external field H to the original system and then use the derivative of \overline{M} with respect to H . This method, though, is quite problematic, because it concerns a numerical derivative at $H=0$. As was discussed by Dayan *et al.*, H must be small enough, so that $M(H)$ is linear in H . This is difficult to achieve, since, below the transition, the size of the region

where that linearity exists shrinks to zero as the size of the system tends to infinity. If, on the other hand, the field is too small, one may encounter numerical problems from roundoff errors.

Our solution to the problem is obtained by using the identity

$$\overline{\Gamma_{ij}} = \frac{1}{\beta h^2} \overline{\langle \sigma_i \rangle h_j}. \quad (9)$$

This identity was used in the past [16–19] but since its proof is very short and simple, we will derive it here again for the sake of completeness of the presentation. We start with the right hand side of Eq. (9):

$$\begin{aligned} \frac{1}{\beta h^2} \overline{\langle \sigma_i \rangle h_j} &= -\frac{1}{\beta} \int \langle \sigma_i \rangle \frac{\partial}{\partial h_j} P\{h\} Dh \\ &= \frac{1}{\beta} \int \frac{\partial \langle \sigma_i \rangle}{\partial h_j} P\{h\} Dh. \end{aligned} \quad (10)$$

This completes the proof since it is easy to see, using the random field Hamiltonian (2), that

$$\frac{1}{\beta} \frac{\partial \langle \sigma_i \rangle}{\partial h_j} = \langle \sigma_i \sigma_j \rangle - \langle \sigma_i \rangle \langle \sigma_j \rangle. \quad (11)$$

Note that identity (9) implies that in order to calculate $\overline{\Gamma_{ij}}$ we need, in principle, only one thermal average $\langle \sigma_i \rangle$. Any decimation scheme will produce one such thermal average, at least. Therefore, $\overline{\Gamma_{ij}}$ can be obtained, for any such decimation scheme, MK for example, by using the same identity (9).

Connected spin-spin correlations and susceptibility. To obtain $\Gamma(\vec{r})$, the following procedure is used. The thermal average of σ_i is calculated in a given realization for i that is one of the surviving spins. It is, then, multiplied by the value of h_j in that realization, where j is a site separated by a vector \vec{r} from i on the original lattice. The product $\langle \sigma_i \rangle h_j$ is then averaged over many realizations. Since the true average should depend only on the vector connecting the sites and that up to a symmetry of the lattice, the statistics can be considerably improved by averaging $\Gamma(\vec{r})$ as follows:

$$\overline{\Gamma(\vec{r})_x} = \frac{1}{\beta h^2} \frac{1}{8} \sum_{i=1}^8 \frac{1}{n_r} \overline{\langle \sigma_i \rangle \sum_{k=1}^{n_r} h_{i_k}}, \quad (12)$$

where i_k runs over all equivalent sites around i that are at a distance r from it. The number of these sites is n_r . In our numerical study, presented in Sec. IV, we have limited ourselves to correlations in the directions of the principal axes of the lattice, so that $n_r=6$ (except, of course, for self-correlations, where $r=0$ and $n_r=1$). For the average susceptibility, the statistics are improved by writing

$$\bar{\chi} = \frac{1}{8h^2} \sum_{i=1}^8 \overline{\langle \sigma_i \rangle \sum_j h_j}. \quad (13)$$

In the following, we will show how to evaluate disconnected correlation functions. Since, in practice, this involves much heavier computations, we just describe how it should be done, and postpone actual numerical application to future publications.

The “sites translation” method for the disconnected spin-spin correlations and the total average energy. The main point in the evaluation of disconnected correlations is that, actually, the method of integrating out many degrees of freedom and remaining with a small number of spins can yield not only σ_i , where i is a surviving spin, but indeed all the local magnetizations. Namely, the method enables one to calculate σ_i for all i in the original lattice. For a given realization, this can be done by translating the eight surviving spins or, equivalently, by translating the field configuration. That is, we choose a realization, evaluate the eight $\langle \sigma_i \rangle$'s corresponding to the surviving spins, then translate the field configuration by one lattice spacing, thus obtaining the local magnetization of the eight sites translated from the original set by one lattice spacing in the opposite direction. This is repeated until all the local magnetizations are obtained. As is easily seen, this involves order of N repetitions of the original procedure. It is clear now how, by obtaining all the $\langle \sigma_i \rangle$'s, we can obtain

$$\overline{S_{ij}} = \overline{\Gamma_{ij}} + \overline{\langle \sigma_i \rangle \langle \sigma_j \rangle} = \frac{1}{\beta h^2} \overline{\langle \sigma_i \rangle h_j} + \overline{\langle \sigma_i \rangle \langle \sigma_j \rangle}. \quad (14)$$

This is generally time consuming but not so bad if we are interested, say, in the energy given by

$$\bar{E} = -J \sum_{\langle i,j \rangle} \overline{\langle \sigma_i \sigma_j \rangle} - \sum_i \overline{h_i \langle \sigma_i \rangle}, \quad (15)$$

for which our method yields the following expression:

$$\bar{E} = -J \sum_{\langle i,j \rangle} \overline{\left(\frac{h_j}{\beta h^2} + \langle \sigma_j \rangle \right) \langle \sigma_i \rangle} - \sum_i \overline{h_i \langle \sigma_i \rangle}. \quad (16)$$

The calculation involves taking the ensemble average of the magnetization multiplied by the field at the same point (which is just $\overline{\Gamma_{ii}}$) and the product $\langle \sigma_i \rangle \langle \sigma_j \rangle$, where i and j are nn 's. To obtain the same degree of accuracy in $\overline{S_{ij}}$ as in $\overline{\Gamma_{ij}}$, for ij nn 's, we need to perform for each field configuration, seven renormalization procedures instead of the one needed for calculating $\overline{\Gamma_{ij}}$. The reason is that we need the original set of surviving spins and the sets obtained from it by the six unit translations in all directions. For other disconnected correlation, the time factor needed to attain the accuracy of the connected correlation is n_r+1 .

Specific heat for systems of random bonds and fields. Next, we show how to obtain the average specific heat for an Ising Hamiltonian with both, random fields and random bonds. The evaluation of the average specific heat, $\bar{C} = kT^2(\overline{\langle \mathcal{H}^2 \rangle} - \langle \mathcal{H} \rangle^2)$, is also made possible by our method. It is given by

$$\bar{C} = \frac{N}{k\beta^2} \left(\frac{N}{2} \sum_{\langle k,l \rangle} \overline{J_{ij}J_{kl}\Gamma_{(ij)(kl)}} + 2 \sum_{\langle k,l \rangle} \overline{h_i J_{kl} \Gamma_{(i)(kl)}} + \sum_j \overline{h_i h_j \Gamma_{ij}} \right), \quad (17)$$

where for A and B , two sets of indices, we define $\Gamma_{AB} \equiv \langle \sigma_A \sigma_B \rangle - \langle \sigma_A \rangle \langle \sigma_B \rangle$ and $\sigma_A \equiv \prod_{i \in A} \sigma_i$. The parentheses in the subscripts of Γ are used to describe the sets of spins. Operating on the three terms of Eq. (17) (from the less complicated on the right to the more complicated on the left), basically using integration by parts, we obtain first

$$\begin{aligned} \overline{h_i h_j \Gamma_{ij}} &= h_i \left(h_j \Gamma_{ij} + \frac{1}{\beta} \langle \sigma_i \rangle \right) - \frac{1}{\beta} h_i \langle \sigma_i \rangle \\ &= \frac{1}{\beta} h_i \left[\frac{\partial}{\partial h_j} (h_j \langle \sigma_i \rangle) - \langle \sigma_i \rangle \right] = \frac{1}{\beta} \left(\frac{h_j^2}{h^2} - 1 \right) h_i \langle \sigma_i \rangle. \end{aligned} \quad (18a)$$

The next two terms are obtained similarly by following the same steps. The only difference is that, since we assume that the random bonds are distributed around some mean value, μ_j , and uncorrelated with a standard deviation Δ_j , as a preliminary step, J_{ij} and J_{kl} are replaced with $\mu_j + \delta J_{ij}$ and $\mu_j + \delta J_{kl}$, respectively. These are collected back by the end of the calculation. The results are similar to Eq. (18a) only with the appropriate indices,

$$\overline{h_i J_{kl} \Gamma_{(i)(kl)}} = \frac{1}{\beta} \left(\frac{J_{kl} \delta J_{kl}}{\Delta_j^2} - 1 \right) h_i \langle \sigma_i \rangle \quad (18b)$$

and

$$\overline{J_{ij} J_{kl} \Gamma_{(ij)(kl)}} = \frac{1}{\beta} \left(\frac{J_{kl} \delta J_{kl}}{\Delta_j^2} - 1 - \delta_{ij,kl} \right) J_{ij} \langle \sigma_i \sigma_j \rangle. \quad (18c)$$

Now, Eq. (18c) is not yet in its final form, since it still contains the term $\langle \sigma_i \sigma_j \rangle$. We thus first need to use Eq. (14) in order to fix that, and then substitute Eqs. (18) back into Eq. (17).

It may seem plausible that techniques of the nature described above can be used also for correlations of quantities coupled by position independent coupling constants (that may be even zero). In principle, this is true because we can always add random couplings with a Gaussian distribution, do the calculation and, in the end, take the variance of those couplings to zero. Practically, it is unclear whether such a procedure is more effective than taking a numerical derivative, since both imply taking the limit where certain couplings tend to zero. (In the random field problem, with no random bonds, we can either add random bonds with variance that will eventually tend to zero, or take a numerical derivative with respect to T .)

IV. NUMERICAL RESULTS

To demonstrate the usefulness of our method, we present in this section results for the less time consuming quantities. We present calculation of the average susceptibility and derive from it the critical exponents, comparing the results with those of Ref. [11], which uses the same renormalization scheme. We also present a calculation of an \vec{r} dependent correlation. We evaluate $\Gamma(\vec{r})$ as a function of temperature and distance, for \vec{r} 's on the principal axes of the lattice. All figures are presented with error bars, although, in some of them, the error bars are too small to be noticed. The errors are the standard deviation calculated from the data. All quantities presented in the figures are dimensionless according to the following. Length is measured in units of lattice constant and, therefore, r and L are dimensionless. Taking the σ_i variables to be dimensionless, $\Gamma(\vec{r})$ is also dimensionless and that is according to Eq. (5). It also means that the parameters h and J of the Hamiltonian (2) are assumed to have the dimensions of energy. h and T are, thus, made dimensionless by rescaling $h/J \rightarrow h$ and $kT/J \rightarrow T$. A dimensionless inverse temperature is then obtained by $\beta J \rightarrow \beta$. Finally, according to Eq. (6), a dimensionless susceptibility is obtained with $\chi^J \rightarrow \chi$.

Using the CS approximation, we choose our input parameters, for calculating the average susceptibility, equal to those used by Dayan *et al.* [11], who also used the CS scheme. We also partially follow their line of analysis for extracting the critical exponents η , γ , and ν . This serves as a baseline, with which part of our results may be compared. We, thus, set $J=1$ and $h=1$ in the Hamiltonian (2) and use $1/\beta$ as temperature. We have calculated the susceptibility as a function of temperature for systems of linear sizes $L=2, 4, 8, 16, 32, 64$, and 128 , averaging, each, over 10 000 realizations of the random field, except for the largest system for which we had to be satisfied with only 1000 realizations. This is shown in Fig. 2(a) in a *log-log* plot. Like Dayan *et al.*, we have also included the mirror image of each random field realization, and that is in order to preserve, in our finite systems, the basic reflection symmetry of the infinite system. As seen in the figure, there is an upward displacement of the average susceptibility for the largest, $L=128$, system. This is probably because the relatively small number of $N=1000$ realizations, for that system, is too little to statistically rely on. It may also be that, since the renormalization procedure is used in an approximation, the large number of renormalization steps generates an error which is too large. It is, therefore, excluded in the following analysis concerning the susceptibility. From Fig. 2(b), we extract the value of η , using the finite size scaling [20] behavior of the susceptibility,

$$\chi(T_c(L)) \sim L^{\gamma/\nu}, \quad (19)$$

together with the scaling relation

$$\gamma = (2 - \eta)\nu. \quad (20)$$

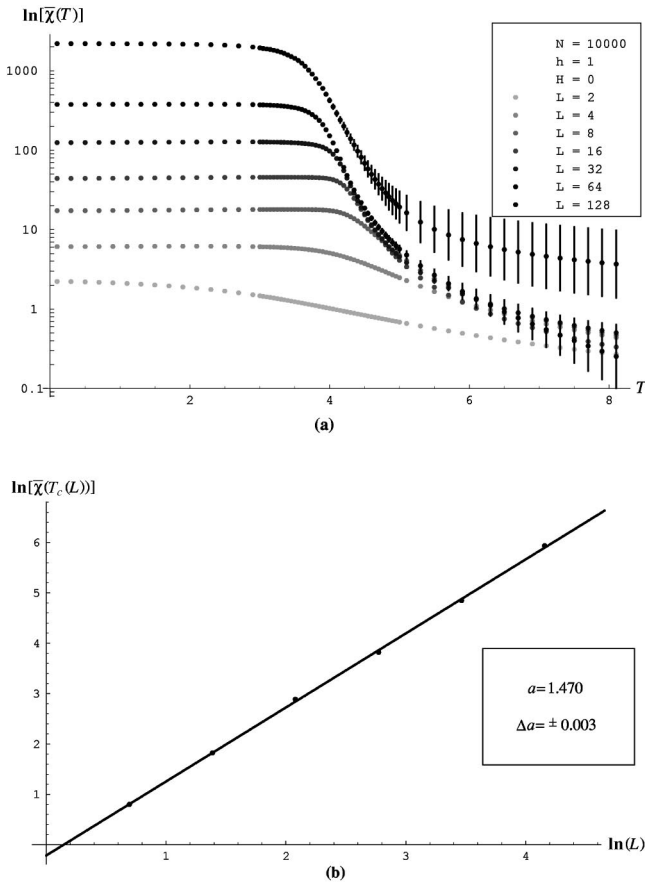

FIG. 2. In (a), the average susceptibility χ is shown as a function of temperature T . It is presented in a *log* plot. The external field H is zero while the standard deviation of the random field is $h = 1$. As indicated in the figure, the different levels of gray scaling correspond to systems of different linear size L . While for L 's up to 64, the system is averaged over 10 000 realizations, the largest, $L = 128$, system is averaged only over 1000 realizations. This may be the cause for the upward displacement of the average susceptibility for the largest, $L = 128$, system. In (b), excluding the largest system, the logarithm of the maximum of the susceptibility is plotted versus the logarithm of L . The value of η is obtained from a linear fit, as, by Eq. (19), the slope a is $\gamma/\nu = 2 - \eta$.

We thus obtain $\eta = 0.53 \pm 0.003$, where the error is the statistical one and errors generated by the renormalization approximate procedure are, therefore, not taken into account.

To estimate the critical temperature T_c of the infinite system together with the critical exponent γ , the logarithm of the average susceptibility of the largest system ($L = 64$) is plotted versus the logarithm of $T - T_c$, for temperatures above T_c and for different values of T_c . Acceptable values of T_c are such that, by lowering the temperature towards T_c , the graph enters a linear region until finite size effects become important. We find that $3.71 \leq T_c \leq 3.95$. The two extremes are presented in Figs. 3(a) and 3(c). For critical temperatures above $T_c = 3.95$, the linear region disappears, while for critical temperatures around 3.71, an opposite curvature begins to appear, as demonstrated in Fig. 3(c) for $T_c = 3.71$. We consider $T_c = 3.8$ [Fig. 3(b)], for which the largest linear region is obtained, to be the more probable value

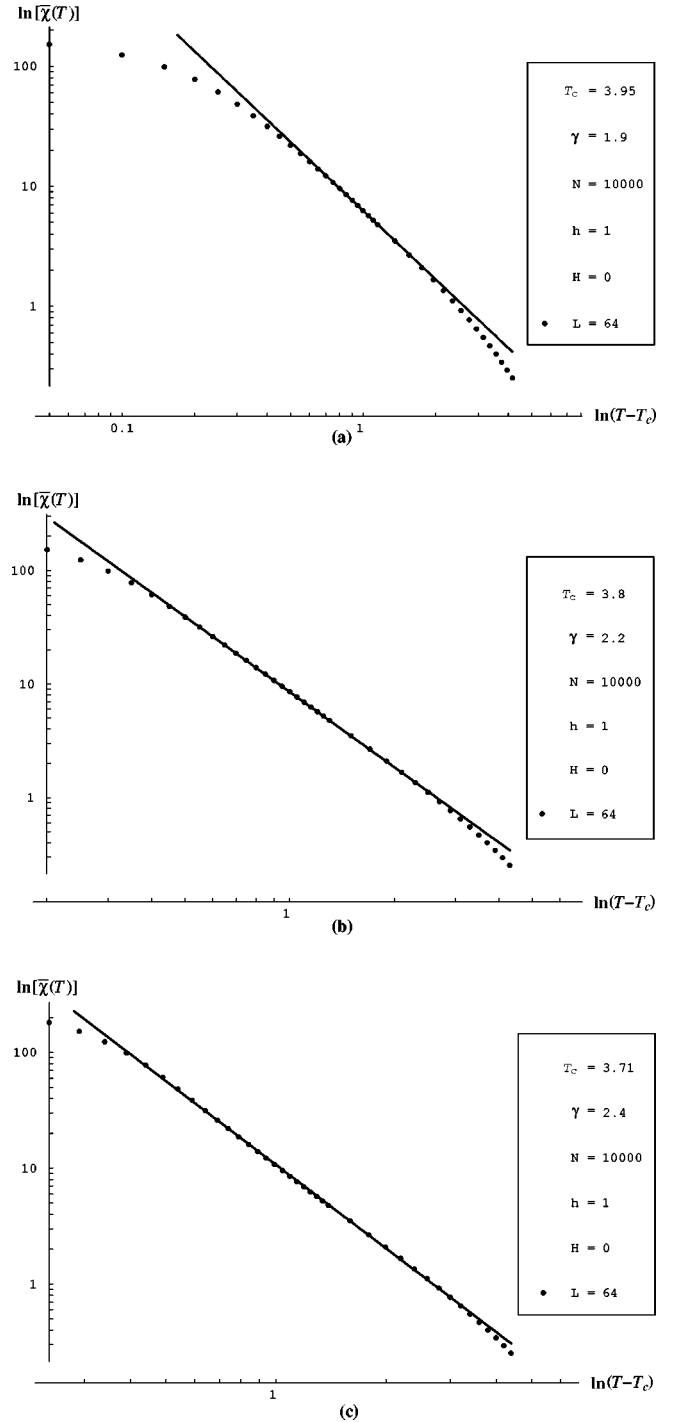

FIG. 3. The logarithm of the average susceptibility of a large system ($L = 64$) is shown as a function of the logarithm of $T - T_c$, for temperatures above T_c and for three different values of T_c . The two extreme, but yet acceptable, values of T_c , as discussed in the text, are presented in (a) and (c). It appears that the largest linear region is obtained for $T_c = 3.8$, as shown in (b). In (c), one may already notice that linearity breaks by the appearance of an opposite curvature. The value of γ for a given T_c is determined by taking the logarithm of both sides of Eq. (21).

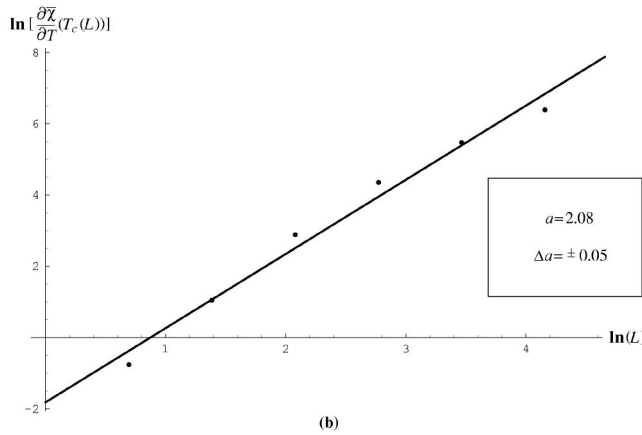
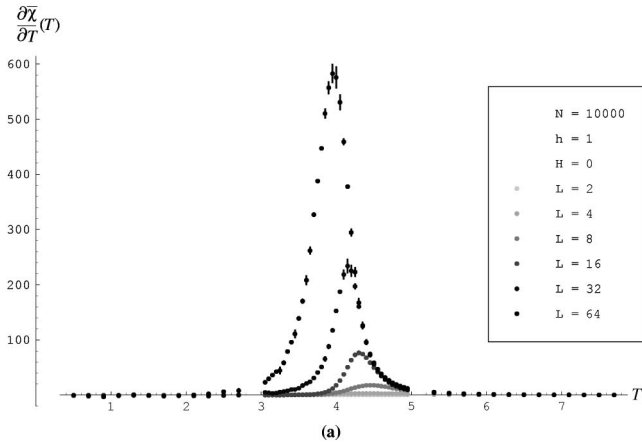

FIG. 4. In (a), the average of the absolute value of the derivative of the susceptibility is shown as a function of temperature. The external field H is zero while the standard deviation of the random field is $h = 1$. As indicated in the figure, the different levels of gray scaling correspond to systems of different linear size L . In (b), the logarithm of the maximum of $-\partial\chi/\partial T$ is plotted versus the logarithm of L . The value of $(\gamma + 1)/\nu$ obtained from the slope of the linear fit here together with γ/ν obtained from the linear fit presented in Fig. 2(b) determine the values for γ and ν .

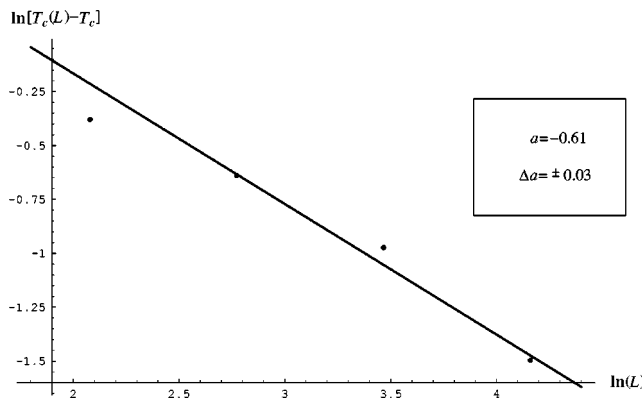

FIG. 5. The logarithm of $T_c(L) - T_c$, for systems of linear size $L = 8, 16, 32, 64$, is plotted versus the logarithm of L . The slope a is $-1/\nu$ and T_c is tuned to 3.77 to make the slope of the linear fit to fit the negative inverse value of $\nu = 1.64$.

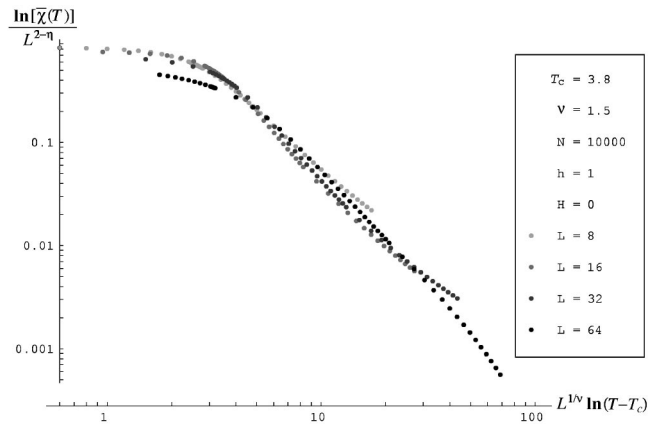

FIG. 6. The logarithm of the susceptibility, scaled by a factor of $1/L^{2-\eta}$, is plotted versus the logarithm of $T - T_c$, scaled by a factor of $L^{-1/\nu}$. The data collapse is shown here for $\eta = 0.53$ and $\nu = 1.5$, which, by Eq. (20), corresponds to $\gamma = 2.2$. The critical temperature is taken to be $T_c = 3.8$.

for the critical temperature. Next, the value of γ for a given T_c is estimated using the critical behavior of the susceptibility,

$$\chi(T) \approx A |T - T_c|^{-\gamma}, \tag{21}$$

where A is some constant. Taking the logarithm of both sides of Eq. (21), for a given T_c , the resulting straight line is, then, fitted to the linear region by varying γ and the constant A . As indicated by Fig. 3, the range of acceptable T_c 's corresponds to a range of possible values for γ : $1.9 \leq \gamma \leq 2.4$, which is quite similar to that obtained by Dayan *et al.* [11]. Using the scaling relation (20), the resulting values for the critical exponent ν are roughly $1.3 \leq \nu \leq 1.65$. For $T_c = 3.8$, the corresponding values for γ and ν are $\gamma = 2.2$ and $\nu = 1.5$.

In a search for a more refined estimation of γ , we turn to the absolute value of the derivative of χ with respect to T . Here we use the numerical derivative of our data for the

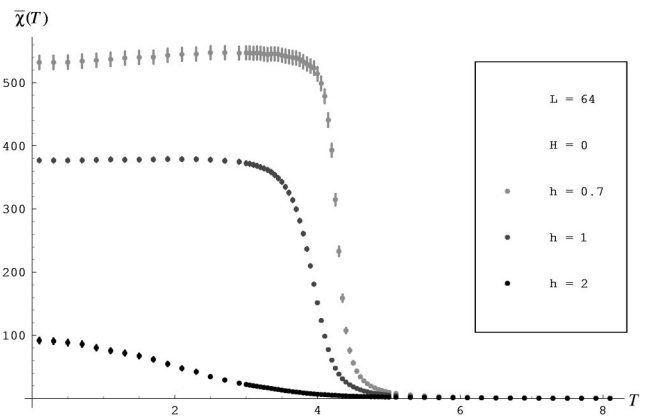

FIG. 7. The average susceptibility $\bar{\chi}$ is shown as a function of temperature T . The external field H is zero, while, as indicated in the figure, the different levels of gray scaling correspond to different values of the standard deviation of the random field. The system is of linear size $L = 64$.

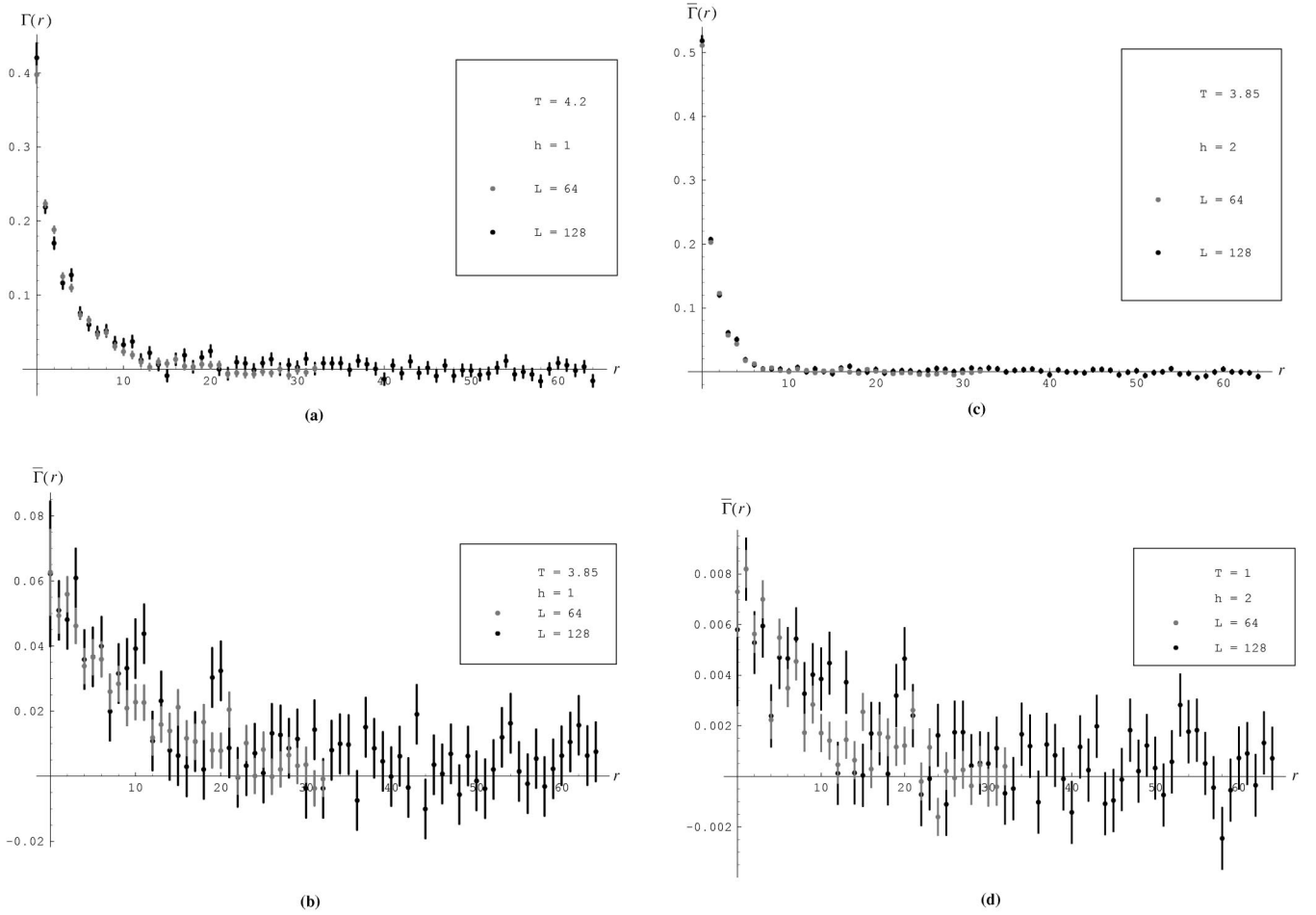

FIG. 8. The average spin-spin correlation function $\bar{\Gamma}$ is shown as a function of distance r taken along the main axes of the lattice and measured in units of lattice constant. The external field H is zero while the standard deviation of the random field is $h=1$ in (a) and (b) and $h=2$ in (c) and (d). As indicated in each figure, the two different levels of gray scaling correspond to systems of different linear size, L , indicating the size independence of $\bar{\Gamma}$ for these temperatures. The points of the larger system, with $L=128$, appear to be more scattered since it is averaged only over 3500 realizations, while the smaller, $L=64$, system is averaged over 10 000 realizations. The different figures correspond to different temperatures. Note the broadening of $\bar{\Gamma}$ as the temperature is reduced towards entering the ordered phase at about $T=3.8$ for $h=1$ and at $T \geq 0$ for $h=2$. Also note that for $h=2$, even at a temperature as low as $T=1$, the correlations are kept relatively short ranged, indicating the persistence of the disorder phase to lower temperatures.

average susceptibility, although one should note that it is, probably, better calculated directly from

$$\frac{\partial \chi}{\partial T} = \frac{k\beta^2}{h^2} \overline{[\langle \mathcal{H}(\sigma_i) \rangle - \langle \mathcal{H} \rangle \langle \sigma_i \rangle] \sum_j h_j}, \quad (22)$$

following our method and using the ideas presented in Sec. III. Similar to the finite size scaling behavior of χ , as given by Eq. (19), its derivative with respect to T is expected to behave as

$$\frac{\partial \chi}{\partial T}(T_c(L)) \sim L^{(\gamma+1)/\nu}. \quad (23)$$

Here $T_c(L)$ is the temperature of the maximum of the derivative for a given L and is, therefore, different from that of the maximum of χ , used in Eq. (19). We have calculated,

then, $-\overline{\partial \chi / \partial T}$ as a function of temperature for systems of linear sizes $L=2,4,8,16,32,64$, as presented in Fig. 4(a). In Fig. 4(b), we have used a linear fit for the logarithm of the maximum of $-\overline{\partial \chi / \partial T}$ plotted versus the logarithm of L , from which we obtain the value of $(\gamma+1)/\nu$. That together with γ/ν obtained earlier from the finite size scaling of χ [Fig. 2(b)] determine the values of γ and ν . We obtain $\gamma = 2.41 \pm 0.07$ and $\nu = 1.64 \pm 0.07$. Note that together with our previously obtained value of $\eta = 0.53 \pm 0.003$, the scaling relation (20) is satisfied.

As a consistency check, we use the set of $T_c(L)$'s of the derivative (as they are better defined than those of the susceptibility itself), together with our estimation of $\nu = 1.64$, to extract the critical temperature T_c , directly from the finite size scaling behavior,

$$|T_c(L) - T_c| \sim L^{-1/\nu}. \quad (24)$$

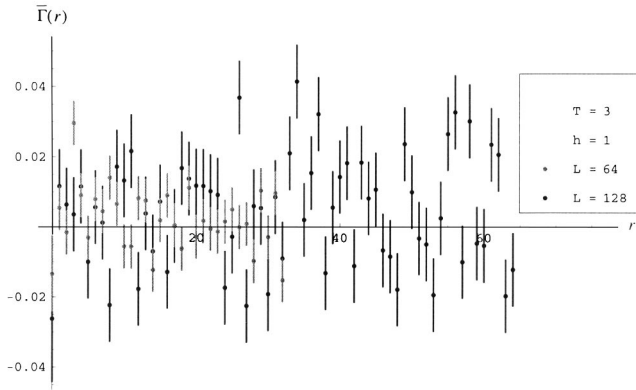

FIG. 9. The average spin-spin correlation function $\bar{\Gamma}$ is again shown as a function of distance r , as in Fig. 8, only for a point on the phase diagram, $(T, h) = (3.0, 1.0)$, located below the transition. Note the noisiness and loss of trend compared with points in the phase diagram located above the transition (Fig. 8).

In Fig. 5, we use a linear fit for the logarithm of $T_c(L) - T_c$ plotted versus the logarithm of L . We obtain $T_c = 3.77$ and that is by tuning T_c to reach a slope that fits the negative inverse value of $\nu = 1.64$.

Taking all the results above into account, we arrive at our final estimation of $\eta = 0.53 \pm 0.003$, $\gamma = 2.2 \pm 0.3$, $\nu = 1.5 \pm 0.15$, and $T_c = 3.8 \pm 0.1$. Note that our result for η satisfies the inequality $2 - \eta < d/2$, by Schwartz and Soffer [16], and

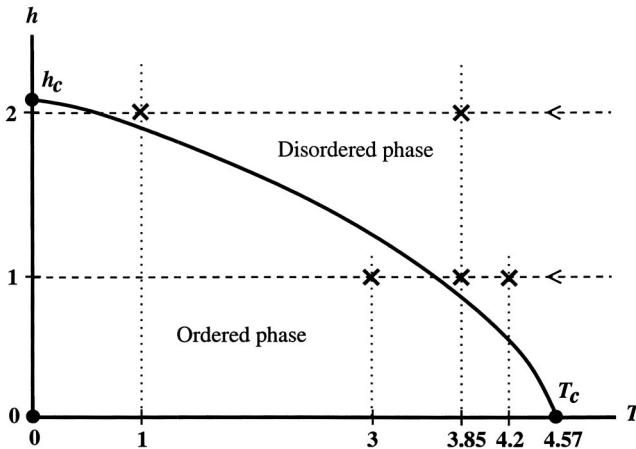

FIG. 10. Schematic phase diagram for the random field Ising system is shown for $d=3$ (the thick lines). The zero-temperature fixed point $(0, h_c)$ controls the whole of the critical line $h_c(T)$ [or $T_c(h)$], while the zero-field thermal fixed point $(T_c, 0)$, that of the pure Ising system, is unstable (It is $T_c = 4.57$ for the Casner-Schwartz renormalization scheme [4].) The lower horizontal dashed line represents the lowering of temperature from the high temperature and disordered phase, at $h = 1 < h_c$. The critical line is, thus, crossed and the ordered phase is penetrated. In our simulations (Fig. 9), this is expressed by the flattening of $\bar{\Gamma}$. The higher horizontal dashed line represents the same, only at $h = 2 \sim h_c$. As indicated by Fig. 8, the level of flattening of $\bar{\Gamma}$ at a given point (T, h) on the phase diagram depends on the distance of that point from the critical line. The crosses in the figure represent the points used in the simulations.

is in good agreement with the results cited in Refs. [11,21–26]. Also, our result for γ is in good agreement with the results of Refs. [11,19,23,27,28], while our result for ν is in good agreement with the results of Refs. [24,26,28–30]. In Fig. 6, we use these values to obtain a data collapse for the susceptibility, scaled by a factor of $1/L^{2-\eta}$, when plotted versus $T - T_c$, scaled by a factor of $L^{-1/\nu}$. It is presented in a *log-log* plot. It should be noted, though, that, within the range of values we have obtained for the parameters above, this data collapse picture, is almost insensitive so that it is impossible to prefer one set of parameters over the other.

We conclude our study of the average susceptibility by presenting it for different values of the strength of the random field (Fig. 7).

We now turn to our evaluation of the average spin-spin correlation function $\bar{\Gamma}$, calculated according to Eq. (12) as discussed in Sec. III. In Fig. 8, we present $\bar{\Gamma}(r)$ for two values of the strength of the random field and for two temperatures. For $h = 1$, we know that $T = 4.2$ is above the transition [Fig. 8(a)]. We present our full results although it is clear that for $r > 10$, the values of $\bar{\Gamma}(r)$ are dominated by noise and therefore meaningless. For $h = 2$ at $T = 3.85$ [Fig. 8(c)], we see a similar picture. Again the function decays quickly and already below $r = 10$, its significance is questionable. It may be expected that increasing the number of realizations considerably may improve the evaluation of the correlation where it is small. As the temperature is lowered for $h = 1$ to $T = 3.85$, that is, at the transition region [Fig. 8(b)], the behavior becomes very noisy and statistically meaningless, but still a trend can be discerned. A similar behavior is observed in Fig. 8(d), for $h = 2$ and $T = 1$. We have chosen to present Figs. 8(b) and 8(d) although, as far as $\bar{\Gamma}(r)$ is concerned, they are not very informative. The reason for doing so is that it is known [11,31–34] that self-averaging is destroyed below the transition and thus we expect the enhanced noisiness of those figures to indicate approach to the transition. The existence of a trend suggests, though, that we may be still above the transition. Figure 9 presents $\bar{\Gamma}(r)$ for $h = 1$ and $T = 3$ (below the transition). The noisiness is larger than in that Figs. 8(b) and 8(d) and no trend as a function of r can be observed. The above observations, in addition to information about the zero-temperature transition ($h_c = 1.956$ according to Ref. [25], while it is $h_c = 2.28$ and $h_c = 2.27$ according to Ref. [26] and Ref. [30], respectively), are consistent with the qualitative phase diagram presented in Fig. 10. The above may suggest an alternative method of identifying the critical temperature by the amount of noise in the data and by losing the trend as a function of r . This line of investigation is postponed, however, to future work.

V. SUMMARY

We have presented a method for calculating thermodynamic quantities, directly from a fully reduced renormalized random system. Our method works with any decimation renormalization scheme, though it is essential that the

random variables are distributed according to a Gaussian distribution. It relies on an exact mathematical transformation, so that the quality of the results obtained by using it depends solely on the quality of the renormalization approximation and the number of realizations considered. As examples, we have developed explicit expressions for the average connected spin-spin correlations, the average susceptibility, the average spin-spin correlations (disconnected), the total average energy, and the average specific heat. We have demonstrated our method by calculating the susceptibility and the connected correlation function for the 3D random field Ising

system. From the results for the susceptibility, we have calculated the following critical exponents: $\eta=0.53\pm 0.003$, $\gamma=2.2\pm 0.3$, and $\nu=1.5\pm 0.15$, while the critical temperature obtained is $T_c=3.8\pm 0.1$ for the case where the variance of the field is $h=1$. As for the average connected spin-spin correlation function, we have presented it as a function of the distance between spins. Starting at the high temperature and disordered phase, it shows a sharp decay. By lowering the temperature towards the critical line, it decays over longer and longer distances until the behavior becomes very noisy and no trend can be detected.

-
- [1] J.J. Binney, N.J. Dowrick, A.J. Fisher, and M.E.J. Newman, *The Theory of Critical Phenomena* (Oxford University Press, Oxford, 1992), Sec. 5.2, p. 115.
- [2] A.A. Migdal, Zh. Éksp. Teor. Fiz. **69**, 1457 (1975) [Sov. Phys. JETP **42**, 743 (1975)].
- [3] L.P. Kadanoff, Ann. Phys. (N.Y.) **100**, 359 (1976); Rev. Mod. Phys. **49**, 267 (1977).
- [4] A. Casher and M. Schwartz, Phys. Rev. B **18**, 3440 (1978).
- [5] C. Tsallis, A.M. Mariz, A. Stella, and L.R. da Silva, J. Phys. A **23**, 329 (1990), Refs. [1–4] therein.
- [6] M. Schwartz and S. Fishman, Physica A **104**, 115 (1980).
- [7] W. Kinzel and E. Domany, Phys. Rev. B **23**, 3421 (1981).
- [8] D. Andelman and A.N. Berker, Phys. Rev. B **29**, 2630 (1984).
- [9] D. Andelman and A. Aharony, Phys. Rev. B **31**, 4305 (1985).
- [10] A.N. Berker and S. Ostlund, J. Phys. C **12**, 4961 (1979).
- [11] I. Dayan, M. Schwartz, and A.P. Young, J. Phys. A **26**, 3093 (1993).
- [12] A. Falicov, A.N. Berker, and S.R. McKay, Phys. Rev. B **51**, 8266 (1995).
- [13] A. Falicov and A.N. Berker, Phys. Rev. Lett. **76**, 4380 (1996); J. Low Temp. Phys. **107**, 51 (1997).
- [14] D. Yeşiltepe and A.N. Berker, Phys. Rev. Lett. **78**, 1564 (1997).
- [15] A.B. Harris and T.C. Lubensky, Phys. Rev. Lett. **33**, 1540 (1974).
- [16] M. Schwartz and A. Soffer, Phys. Rev. Lett. **55**, 2499 (1985).
- [17] M. Schwartz and A. Soffer, Phys. Rev. B **33**, 2059 (1986).
- [18] M. Schwartz, M. Gofman, and T. Natterman, Physica A **178**, 6 (1991).
- [19] M. Gofman, J. Adler, A. Aharony, A.B. Harris, and M. Schwartz, Phys. Rev. Lett. **71**, 1569 (1993); **71**, 2841 (1993); Phys. Rev. B **53**, 6362 (1996).
- [20] The use of finite size scaling in the context of RSRG was first introduced by P.J. Reynolds, H.E. Stanley, and W. Klein, Phys. Rev. B **21**, 1223 (1980).
- [21] H.F. Cheung, Phys. Rev. B **33**, 6191 (1986).
- [22] A.T. Ogielski and D.A. Huse, Phys. Rev. Lett. **56**, 1298 (1986).
- [23] H. Rieger and A.P. Young, J. Phys. A **26**, 5279 (1993).
- [24] H. Rieger, Phys. Rev. B **52**, 6659 (1995).
- [25] J-Y. Fortin and P.C.W. Holdsworth, J. Phys. A **29**, L539 (1996); **31**, 85 (1998).
- [26] A.K. Hartmann and A.P. Young, Phys. Rev. B **64**, 214419 (2001).
- [27] M. Schwartz, J. Phys. C **21**, 753 (1988).
- [28] Q. Feng, Q.J. Harris, R.J. Birgeneau, and J.P. Hill, Phys. Rev. B **55**, 370 (1997).
- [29] R.J. Birgeneau, R.A. Cowley, G. Shirane, and H. Yoshizawa, Phys. Rev. Lett. **54**, 2147 (1985).
- [30] A.A. Middleton and D.S. Fisher, Phys. Rev. B **65**, 134411 (2002).
- [31] S. Wiseman and E. Domany, Phys. Rev. E **52**, 3469 (1995).
- [32] A. Aharony and A.B. Harris, Phys. Rev. Lett. **77**, 3700 (1996).
- [33] S. Wiseman and E. Domany, Phys. Rev. Lett. **81**, 22 (1998); Phys. Rev. E **58**, 2938 (1998).
- [34] A. Aharony, A.B. Harris, and S. Wiseman, Phys. Rev. Lett. **81**, 252 (1998).