

Generalized synchronization of chaos in He-Ne lasersA. Uchida,¹ K. Higa,¹ T. Shiba,¹ S. Yoshimori,¹ F. Kuwashima,² and H. Iwasawa³¹*Department of Electronics and Computer Systems, Takushoku University, 815-1 Tatemachi, Hachioji, Tokyo 193-0985, Japan*²*Hiroshima National College of Maritime Technology, 4272-1 Higashino, Oosakamishima-cho, Toyota-gun, Hiroshima 725-0231, Japan*³*Hiroshima Kokusai Gakuin University, 6-20-1 Nakano, Akiku, Hiroshima-shi, Hiroshima 739-0321, Japan*

(Received 31 July 2002; revised manuscript received 28 April 2003; published 18 July 2003)

We experimentally demonstrate synchronization of chaos in one-way coupled He-Ne lasers with optical feedback. We observe different types of synchronization such as identical synchronization, inverse synchronization, and random amplification. These dynamics are maintained only for a short duration of several hundred milliseconds. We also observe generalized synchronization of chaos by using one master and two slave lasers. The generalized synchronization is achieved for a long duration of tens of seconds under injection locking. The generalized synchronization is always maintained while the injection locking is achieved.

DOI: 10.1103/PhysRevE.68.016215

PACS number(s): 05.45.Xt, 42.65.Sf, 42.55.Lt

I. INTRODUCTION

Synchronization of chaos in laser systems has recently attracted increasing interest because of its potential applications in optical secure communications and optical spread spectrum communications [1,2]. Synchronization of chaos in lasers has been experimentally investigated for variety of lasers in one-way coupling configurations [3–16] and mutually coupled configurations [17–23]. Many different types of synchronization phenomena have been observed in laser systems, such as identical synchronization [3–23], inverse synchronization [24,25], lag synchronization [26,27], phase synchronization [28–32], and generalized synchronization [33–35]. Identical synchronization is a simple case of synchronization, where two temporal wave forms are exactly identical. Inverse synchronization can be observed when one of two identical wave forms is inverted from the other. The existence of time delay between two identical chaotic wave forms implies lag synchronization. The phase of chaotic temporal wave forms can be synchronized, which is called phase synchronization. Generalized synchronization is a more generic type of synchronization where there is a functional relationship between two nonidentical wave forms. Although many kinds of synchronization have been observed in different laser systems, the condition for achieving each synchronization phenomenon has not been well investigated so far.

For optically (coherently) coupled laser systems, the achievement of synchronization of chaos is strongly dependent upon injection locking [12], which is the frequency pulling effect of fast oscillations of optical carrier [36]. Frequency locking of the fast optical carriers between optically coupled lasers results in the synchronization of slow envelope components that correspond to chaotic oscillations [12]. Identical synchronization of chaos is observed in many kinds of optically coupled systems under the injection locking condition [5–14]. However, the relationship between synchronization of chaos and injection locking has not been well known for the other kinds of synchronization phenomena; for example, there has been no report of generalized synchronization of chaos in optically coupled laser systems, to the best of our knowledge.

Chaotic dynamics have been experimentally and numeri-

cally reported in He-Ne lasers, which have been commonly used as one of the standardized lasers. Chaotic oscillations have been observed in He-Ne lasers at the wavelength of 632.8 nm [37–41], 1.15 μm [42–44], and 3.39 μm [45–48]. Chaotic instabilities in He-Ne lasers can be generated by delayed optical feedback [39–41,49], frequency modulation [50], and multimode dynamics [37,38]. Although the generation of chaos in He-Ne lasers has been well investigated [39–41,51,52], synchronization phenomena in chaotic He-Ne lasers have not been reported so far. The characteristics of synchronization phenomena in chaotic He-Ne lasers are important issues as well as the dynamics in other laser systems [53,54].

In this paper, we demonstrate the synchronization of chaos in optically coupled He-Ne lasers with optical feedback in a one-way coupling configuration. We use two He-Ne lasers for the observation of identical synchronization. We also observe generalized synchronization of chaos by using one master and two slave lasers.

II. IDENTICAL SYNCHRONIZATION OF CHAOS**A. Experimental setup**

Figure 1 shows our experimental setup for identical synchronization of chaos. We use two He-Ne lasers (NEC: GLG5380) as a master and a slave laser, which are linearly polarized. The gas cylinder of each laser is surrounded by a copper holder in order to maintain homogeneous distribution of temperature. The temperatures of the He-Ne lasers are controlled by thermoelectric coolers (resolution of 0.01 K) for fine tuning of the laser frequencies.

Chaotic outputs in He-Ne lasers are obtained at frequencies of tens of hertz by optical feedback from the external mirror [39–41]. We set an external mirror in front of the master laser at the distance of 0.6 m to obtain chaotic oscillations. A fraction of the master laser output is injected into the slave-laser cavity for chaos synchronization. An optical isolator is used to achieve one-way coupling from the master to the slave lasers (isolation of -60 dB). A $\lambda/2$ wave plate is used for changing the direction of polarization. The polarization of the master laser is rotated at 45° of that of the slave laser. Due to the difference of polarization direction between

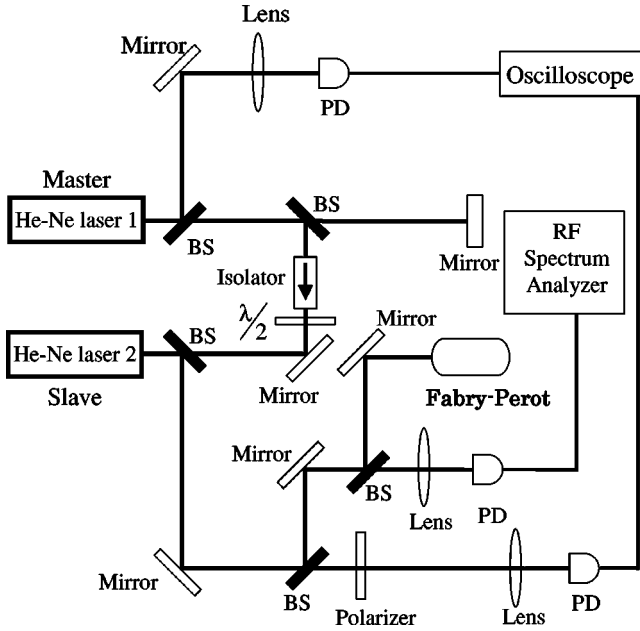

FIG. 1. Experimental setup for identical synchronization of chaos in two He-Ne lasers. BS, beam splitter; PD, photodiode; $\lambda/2$, half-wave plate.

the two lasers, we can separate the output of the slave laser from the output of the master laser reflected from the facet of the slave-laser cavity, by using a polarizer. Chaotic temporal wave forms are detected by photodiodes (Hamamatsu Photonics Inc., G3804) and digital oscilloscopes (Sony Tektronix, TDS410). The optical frequencies of the lasers are measured by a Fabry-Perot scanning interferometer (TEC-Optics, SA-2) with a free spectral range of 2.0 GHz. The beat frequencies between the two lasers are measured with a radio-frequency (rf) spectrum analyzer (Advantest, R3131) through a photodiode.

B. Experimental results

The achievement of synchronization of chaos is highly dependent upon injection locking performance in the slave oscillator. The optical frequencies between the two individual lasers can be perfectly matched by injection locking when the frequency difference is set within an injection locking range. The injection locking range $\Delta\nu_{\text{lock}}$ is described as [36]

$$\Delta\nu_{\text{lock}} \leq \frac{\nu_s}{Q_s} \sqrt{\frac{P_m}{P_s}}, \quad (2.1)$$

where ν_s is the optical frequency in the slave laser; Q_s is the Q value of the slave-laser cavity; and P_m , P_s is the injected power from the master and the intracavity power of the slave laser, respectively. The injection locking range is dependent on the injection power from the master laser. In our experiments, the injection locking range is ≈ 1.5 MHz.

The optical frequencies of He-Ne lasers can be tuned linearly as a function of the temperature of the lasers. The temperature of the gas cylinder in the master laser is kept con-

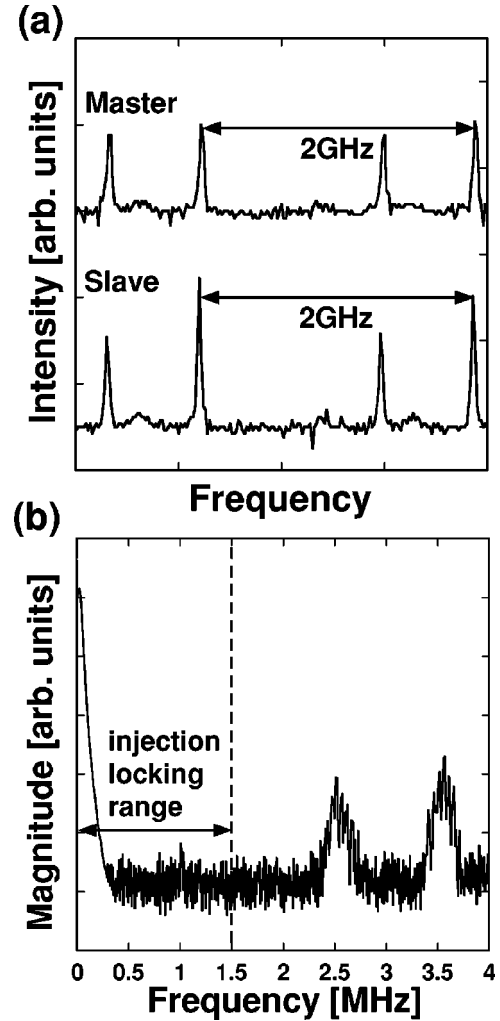

FIG. 2. (a) Optical spectra measured by the Fabry-Perot scanning interferometer. (b) Beat frequencies between the two lasers measured by the radio-frequency spectrum analyzer. The injection locking range is within 1.5 MHz.

stant. The temperature of the slave laser is changed so that the difference of the two optical frequencies is within the injection locking range. The optical frequencies are adjusted from a low resolution to a high resolution by monitoring the spectra with the Fabry-Perot scanning interferometer and the radio-frequency spectrum analyzer as shown in Fig. 2. We observe that both of the lasers oscillate with two longitudinal modes, whose frequency interval is 684 MHz in Fig. 2(a). Two frequency beats between the two longitudinal modes of the master and slave lasers are observed on the radio-frequency spectrum analyzer as shown in Fig. 2(b). The difference of the two beat frequencies is 1.1 MHz. When both of the beat frequencies are settled within the injection locking range (~ 1.5 MHz) with more accurate temperature control, the beat frequencies disappear and the two laser frequencies are perfectly matched.

Figures 3(a) and 3(b) show the chaotic temporal wave forms and distribution of correlation plots between the two laser outputs. The output of the slave laser is stable without injection locking. There is no correlation between the outputs

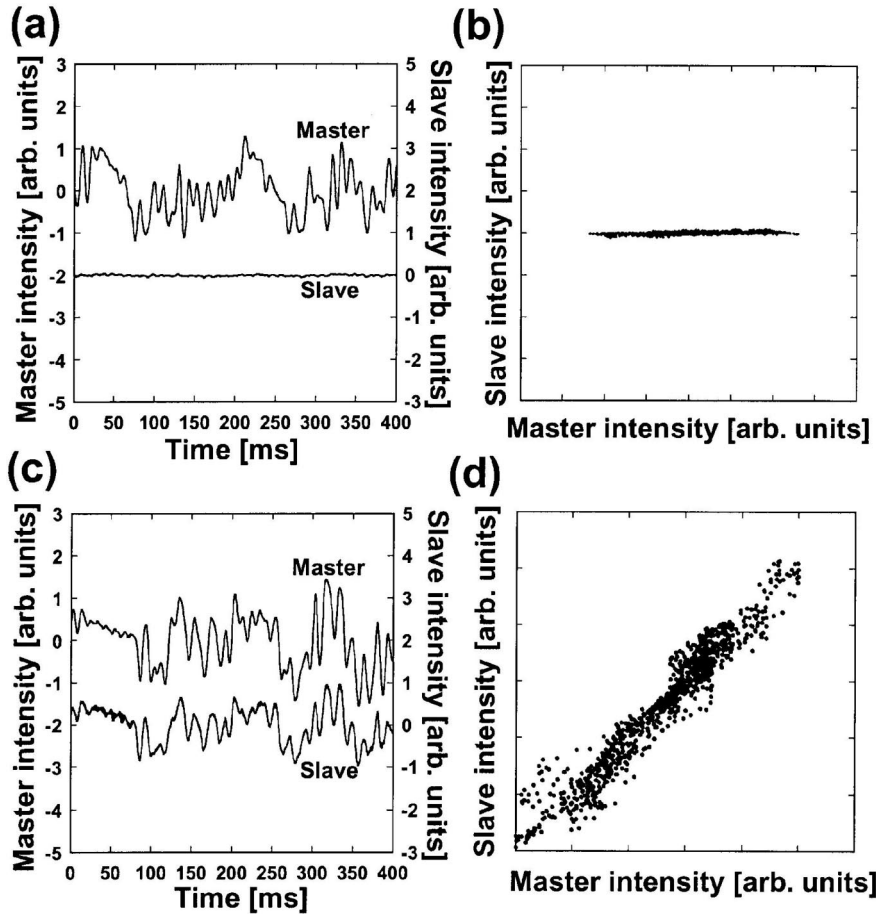

FIG. 3. Chaotic temporal wave forms and correlation plots for the two laser outputs: (a), (b) without synchronization and (c), (d) with identical synchronization. The synchronization is maintained for several hundred milliseconds.

of the two lasers. When a fraction of the master laser output is injected into the slave-laser cavity and the beat frequencies of the two lasers are adjusted within the injection locking range under precise temperature control, the two chaotic oscillations are synchronized as shown in Fig. 3(c). A linear correlation between the two laser outputs observed in Fig. 3(d) exhibits the identical synchronization. However, this synchronization can be maintained only for several hundred milliseconds even though the injection locking of the two laser frequencies is maintained. The identical synchronization is observed only in the boundary of the injection locking range for a short time. These results are different from the synchronization of chaos in optically coupled semiconductor lasers [5–10] and microchip lasers [11–14].

We observe some interesting phenomena of synchronization dynamics under injection locking. Figure 4 shows some examples of synchronization between the two lasers as the beat frequency is changed within the injection locking range. We observe inverse synchronization [Figs. 4(a,b)], generalized case of synchronization [Figs. 4(c,d)], and random amplification of the slave-laser oscillations [Figs. 4(e,f)] as the beat frequencies approach 0 Hz. These phenomena are observed for a short time (several hundred milliseconds) and switch to each other. It is difficult to obtain a certain rule of synchronization, and the relationship between the synchronization and injection locking is not clearly observed.

To evaluate the quantitative accuracy of chaos synchronization, variance σ^2 of the normalized correlation plot from a

best-fit linear relation is used, which is defined as [12]

$$\sigma^2 = \frac{1}{N} \sum_i^N (I_{m,i} - I_{s,i})^2, \quad (2.2)$$

where N is the total number of sampling of the temporal wave forms, $I_{m,i}$ and $I_{s,i}$ are the normalized intensities of the master and the slave lasers at the i th sampling point. Smaller variance σ^2 implies higher accuracy of chaos synchronization. For example, the variance of Fig. 3(d) and Fig. 4(f) are $\sigma^2 = 0.0047$ and 0.32 , respectively. Figure 5 shows the accuracy of synchronization as a function of the average value of the two beat frequencies. The accuracy is distributed to different values and there is no clear relationship between the accuracy of synchronization and the beat frequencies. The accuracy is widely distributed even within the injection locking range, because many kinds of synchronization appear as shown in Figs. 3 and 4. Therefore, synchronization properties are always changed within the injection locking range.

III. GENERALIZED SYNCHRONIZATION OF CHAOS

A. Experimental setup

To evaluate the synchronization properties in optically coupled He-Ne lasers, we conduct the observation of generalized synchronization of chaos. The definition of generalized synchronization is the case if a functional relation exists

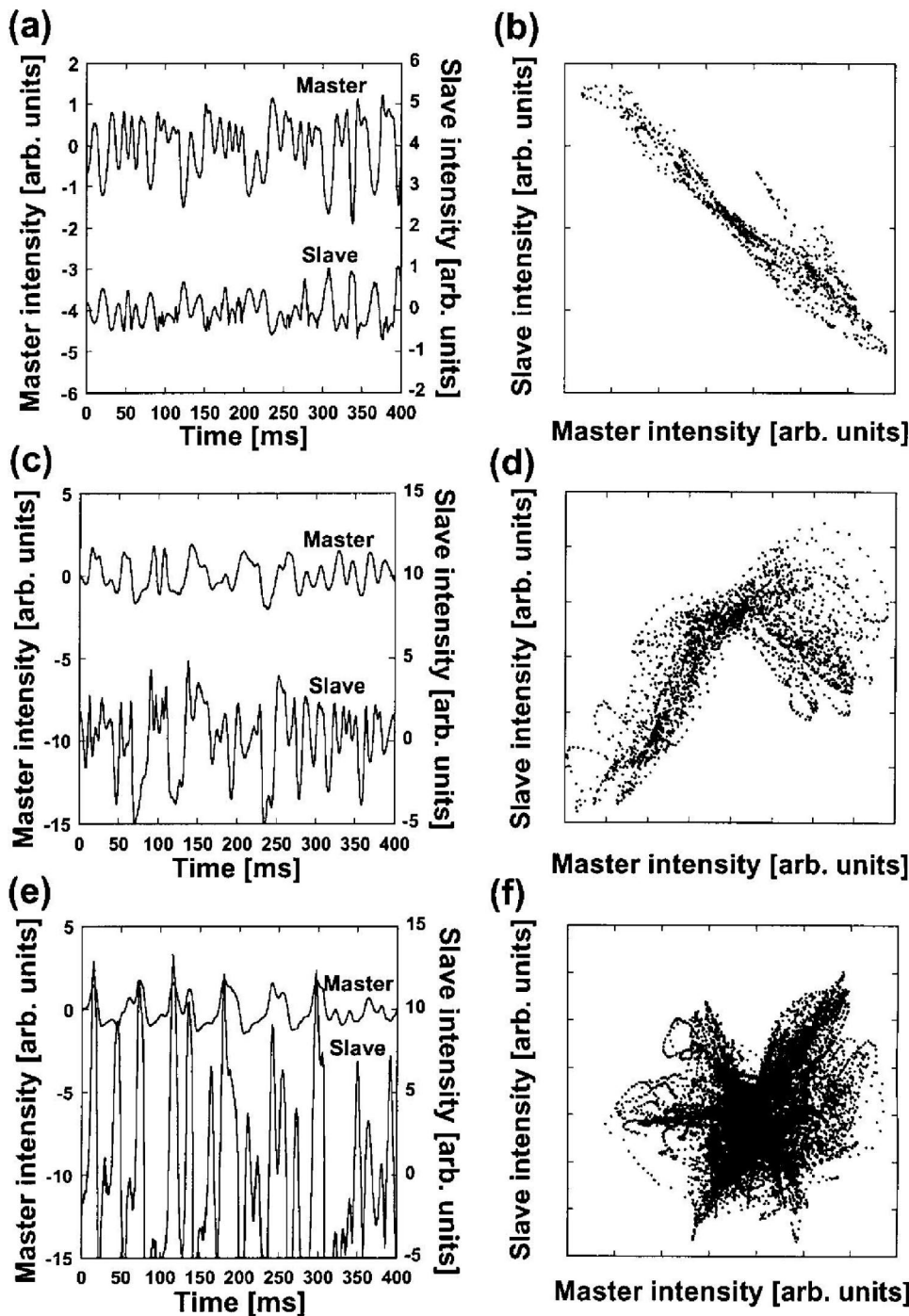

FIG. 4. Examples of chaotic temporal wave forms and correlation plots for the two laser outputs at various beat frequencies within the injection locking range: (a), (b) inverse synchronization; (c), (d) generalized case of synchronization; (e), (f) random amplification. The synchronization dynamics switch to each other.

between the states of both systems. Rulkov and co-workers [55,56] have suggested a simple way for the detection of generalized synchronization by plotting a variable of one of the response systems versus the same variable of the other system, identical response system starting from different initial conditions. In the case of generalized synchronization, the resulting curve converges to the diagonal [57].

The experimental setup for the demonstration of generalized synchronization is shown in Fig. 6. We use an additional He-Ne laser and construct a new system with one master laser (referred to as M) and two slave lasers (referred to as $S1$ and $S2$). An external mirror is set in front of the master

laser for generation of chaos, whereas the two slave lasers have stable laser outputs without optical injection from the master laser. A beam from the chaotic master laser is divided into two beams and injected into the cavities of the two slave lasers. The temperatures of the three lasers are precisely controlled with thermoelectric coolers. The temporal wave forms of the three lasers are simultaneously detected by the digital oscilloscope through photodiodes. The beat frequencies between M and $S1$ (referred to as $M-S1$) and between M and $S2$ (referred to as $M-S2$) are also measured by the rf spectrum analyzer through a photodiode. The other components in this setup are the same as in Fig. 1.

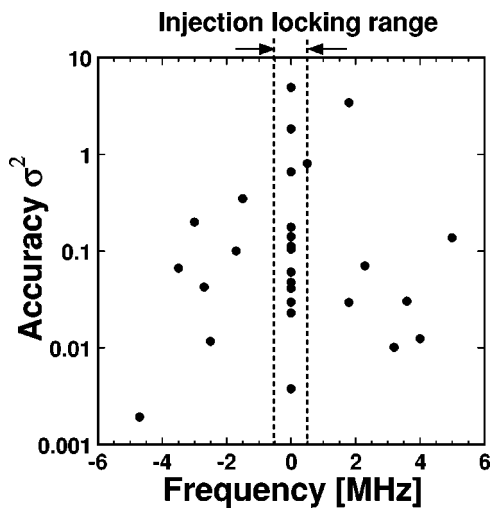

FIG. 5. Accuracy of synchronization as a function of the average value of the two beat frequencies.

B. Experimental results

We adjust the temperatures of *S1* and *S2* for matching the beat frequencies of *M-S1* and *M-S2*. When both of the beat frequencies are set within the injection locking range, the beat frequencies disappear and chaotic oscillations are observed in both of *S1* and *S2*. Figure 7 shows the temporal wave forms of *M*, *S1*, and *S2*, and the correlation plots of *M-S1* and *M-S2*. The laser outputs oscillate chaotically in

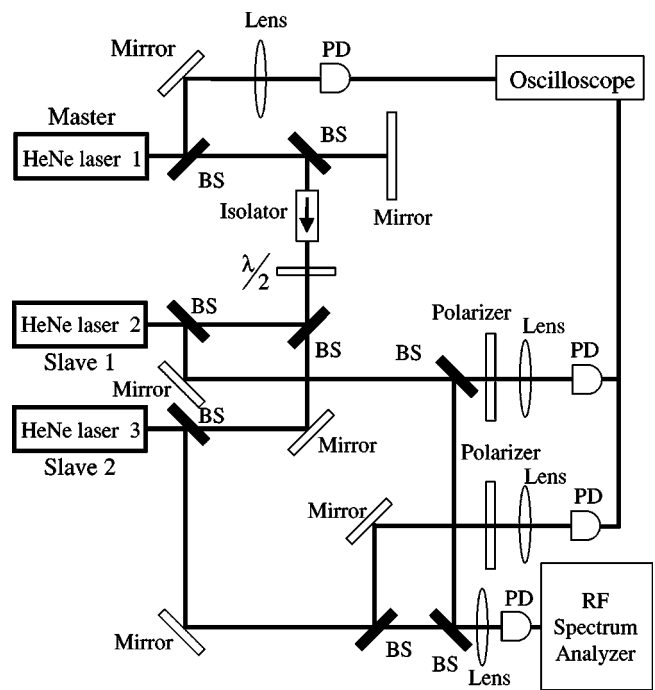

FIG. 6. Experimental setup for generalized synchronization of chaos in three He-Ne lasers. The output of one master laser is injected into two slave lasers. BS, beam splitter; PD, photodiode; $\lambda/2$, half-wave plate.

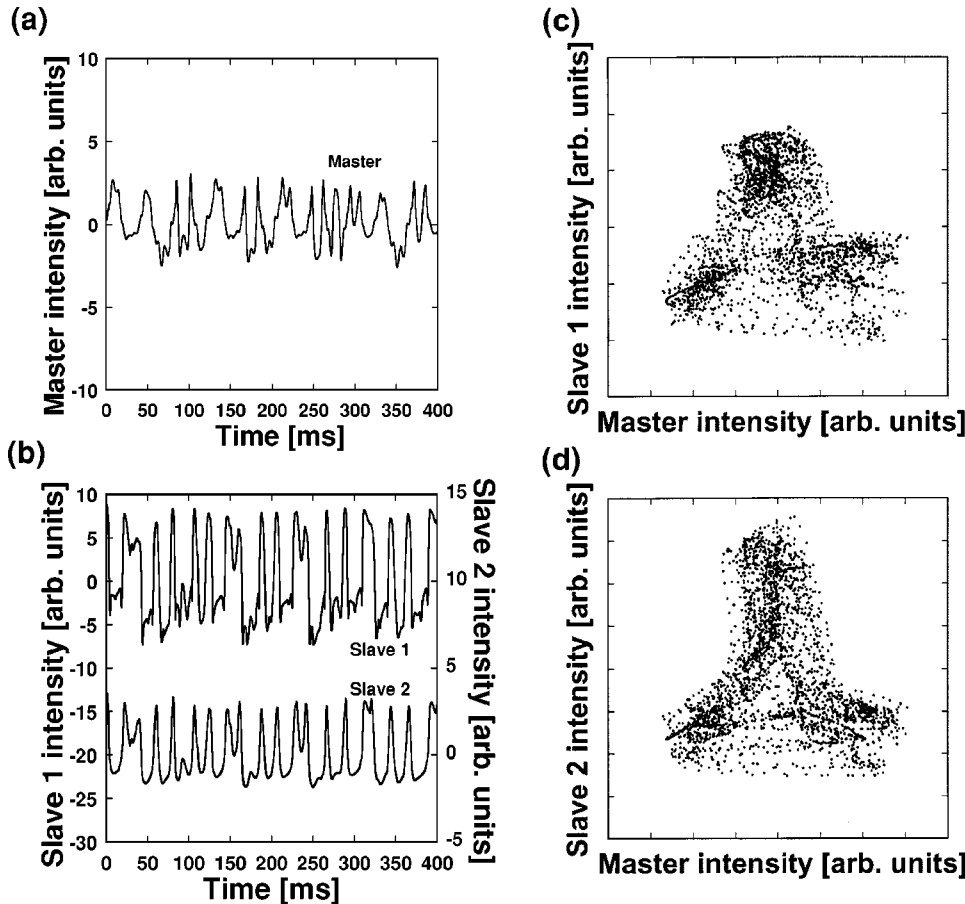

FIG. 7. (a) Chaotic temporal wave form of the master laser. (b) Chaotic temporal wave forms of the slave lasers 1 and 2. (c) Correlation plots between the master and slave 1. (d) Correlation plots between the master and slave 2.

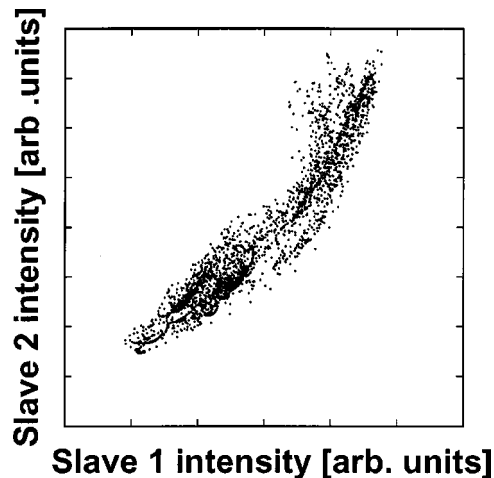

FIG. 8. Correlation plots between the slave 1 and slave 2 obtained from Fig. 7(b). Diagonal correlation is observed, which implies the existence of generalized synchronization of chaos between the master and slave lasers. The synchronization is maintained for tens of seconds while the injection locking is achieved.

all the three lasers. However, the outputs of M and $S1$ are not linearly correlated as shown in Fig. 7(c). The relationship between M and $S2$ also has no diagonal correlation as shown in Fig. 7(d). The shape of the correlation plots of Figs. 7(c) and 7(d) looks very similar. In fact, the shape of the correlation plots is changing in time for a short duration. Figure 8 shows the correlation plots between $S1$ and $S2$. A linear correlation is clearly observed between $S1$ and $S2$ in Fig. 8. This diagonal correlation of $S1$ - $S2$ implies the existence of generalized synchronization between the master and slave lasers [55–57]. We thus conclude that generalized synchronization of chaos is experimentally confirmed in optically coupled He-Ne lasers. It is worth noting that the diagonal correlation of $S1$ - $S2$ is maintained for a long duration (more than tens of seconds) while the injection locking is achieved

for both M - $S1$ and M - $S2$. The duration maintaining the linear correlation of $S1$ - $S2$ is much longer than that for identical synchronization of M - $S1$ shown in Fig. 3(d). The generalized synchronization is always achieved when the injection locking is maintained between the two lasers, whereas the other synchronization phenomena shown in Figs. 3 and 4 are not stable under the injection locking condition. These results are different from the synchronization phenomena in optically coupled microchip lasers, where identical synchronization can be maintained under the injection locking range [12–14].

IV. CONCLUSION

We have experimentally demonstrated synchronization of chaos in optically coupled He-Ne lasers with optical feedback in a one-way coupling configuration. We have observed different types of synchronization, i.e., identical synchronization, inverse synchronization, and random amplification. These dynamics are observed only for a short duration of several hundred milliseconds. We have also demonstrated generalized synchronization of chaos by using one master and two slave lasers. The generalized synchronization has been experimentally achieved for a long duration of tens of seconds. The generalized synchronization is always maintained while the injection locking is achieved.

ACKNOWLEDGMENTS

We thank K. Yoshimura for helpful discussions. We thank H. Niki for providing the Fabry-Perot scanning interferometer. We are also thankful for expert technical assistance from M. Hoshino. This work was financially supported by The Sumitomo Foundation, The Telecommunications Advancement Foundation, the Sasakawa Scientific Research Grant from The Japan Science Society, The Promotion and Mutual Aid Corporation for Private Schools of Japan, and Grant-in-Aid for Encouragement of Young Scientists from the Japan Society for the Promotion of Science.

-
- [1] G.D. VanWiggeren and R. Roy, *Science* **279**, 1198 (1998).
 - [2] J.-P. Goedgebuer, L. Larger, and H. Porte, *Phys. Rev. Lett.* **80**, 2249 (1998).
 - [3] T. Sugawara, M. Tachikawa, T. Tsukamoto, and T. Shimizu, *Phys. Rev. Lett.* **72**, 3502 (1994).
 - [4] T. Tsukamoto, M. Tachikawa, T. Hirano, T. Kuga, and T. Shimizu, *Phys. Rev. E* **54**, 4476 (1996).
 - [5] S. Sivaprakasam and K.A. Shore, *Opt. Lett.* **24**, 466 (1999).
 - [6] Y. Takiguchi, H. Fujino, and J. Ohtsubo, *Opt. Lett.* **24**, 1570 (1999).
 - [7] H. Fujino and J. Ohtsubo, *Opt. Lett.* **25**, 625 (2000).
 - [8] I. Fischer, Y. Liu, and P. Davis, *Phys. Rev. A* **62**, 011801(R) (2000).
 - [9] I. Wallace, D. Yu, W. Lu, and R.G. Harrison, *Phys. Rev. A* **63**, 013809 (2000).
 - [10] A. Uchida, Y. Liu, I. Fischer, P. Davis, and T. Aida, *Phys. Rev. A* **64**, 023801 (2001).
 - [11] A. Uchida, M. Shinozuka, T. Ogawa, and F. Kannari, *Opt. Lett.* **24**, 890 (1999).
 - [12] A. Uchida, T. Ogawa, M. Shinozuka, and F. Kannari, *Phys. Rev. E* **62**, 1960 (2000).
 - [13] A. Uchida, S. Kinugawa, T. Matsuura, and S. Yoshimori, *Opt. Lett.* **28**, 19 (2003).
 - [14] A. Uchida, S. Kinugawa, T. Matsuura, and S. Yoshimori, *Phys. Rev. E* **67**, 026220 (2003).
 - [15] Y. Liu and P. Davis, *Opt. Lett.* **25**, 475 (2000).
 - [16] S. Tang and J.M. Liu, *Opt. Lett.* **26**, 596 (2001).
 - [17] R. Roy and K.S. Thornburg, Jr., *Phys. Rev. Lett.* **72**, 2009 (1994).
 - [18] Y. Liu, P.C. de Oliveira, M.B. Danailov, and J.R. Rios Leite, *Phys. Rev. A* **50**, 3464 (1994).
 - [19] D.Y. Tang, R. Dykstra, and N.R. Heckenberg, *Phys. Rev. A* **54**, 5317 (1996).
 - [20] M. Möller, B. Forsmann, and W. Lange, *Quantum Semiclass. Opt.* **10**, 839 (1998).
 - [21] J.R. Terry, K.S. Thornburg, Jr., D.J. DeShazer, G.D. VanWig-

- geren, S. Zhu, P. Ashwin, and R. Roy, *Phys. Rev. E* **59**, 4036 (1999).
- [22] K. Otsuka, R. Kawai, S.-L. Hwong, J.-Y. Ko, and J.-L. Chern, *Phys. Rev. Lett.* **84**, 3049 (2000).
- [23] T. Heil, I. Fischer, W. Elsässer, J. Mulet, and C.R. Mirasso, *Phys. Rev. Lett.* **86**, 795 (2001).
- [24] S. Sivaprakasam, I. Pierce, P. Rees, P.S. Spencer, K.A. Shore, and A. Valle, *Phys. Rev. A* **64**, 013805 (2001).
- [25] I. Wedekind and U. Parlitz, *Int. J. Bifurcation Chaos Appl. Sci. Eng.* **11**, 1141 (2001).
- [26] B.F. Kuntsevich and A.N. Pisarchik, *Phys. Rev. E* **64**, 046221 (2001).
- [27] A. Barsella and C. Lepers, *Opt. Commun.* **205**, 397 (2002).
- [28] E. Allaria, F.T. Arecchi, A. Di Garbo, and R. Meucci, *Phys. Rev. Lett.* **86**, 791 (2001).
- [29] D.J. DeShazer, R. Breban, E. Ott, and R. Roy, *Phys. Rev. Lett.* **87**, 044101 (2001).
- [30] S. Boccaletti, E. Allaria, R. Meucci, and F.T. Arecchi, *Phys. Rev. Lett.* **89**, 194101 (2002).
- [31] R. McAllister, R. Meucci, D. DeShazer, and R. Roy, *Phys. Rev. E* **67**, 015202 (2003).
- [32] C.S. Zhou, J. Kurths, E. Allaria, S. Boccaletti, R. Meucci, and F.T. Arecchi, *Phys. Rev. E* **67**, 015205(R) (2003).
- [33] D.Y. Tang, R. Dykstra, M.W. Hamilton, and N.R. Heckenberg, *Phys. Rev. E* **57**, 5247 (1998).
- [34] D.Y. Tang, R. Dykstra, M.W. Hamilton, and N.R. Heckenberg, *Chaos* **8**, 697 (1998).
- [35] J.R. Terry and G.D. VanWiggeren, *Chaos, Solitons Fractals* **12**, 145 (2001).
- [36] A.E. Siegman, *Lasers* (University Science Books, Mill Valley, CA, 1986).
- [37] V.I. Chetverikov, *Sov. Tech. Phys. Lett.* **11**, 190 (1985).
- [38] M.V. Danileiko, A.L. Kravchuk, V.N. Nechiporenko, A.M. Tselinko, and L.P. Yatsenko, *Sov. J. Quantum Electron.* **16**, 1420 (1986).
- [39] F. Kuwashima, I. Kitazima, and H. Iwasawa, *Jpn. J. Appl. Phys., Part 2* **37**, L325 (1998).
- [40] F. Kuwashima, T. Ichikawa, I. Kitazima, and H. Iwasawa, *Jpn. J. Appl. Phys., Part 1* **38**, 6321 (1999).
- [41] F. Kuwashima, I. Kitazima, and H. Iwasawa, *Jpn. J. Appl. Phys., Part 1* **40**, 601 (2001).
- [42] L.A. Melnikov, E.M. Rabinovich, and V.V. Tuchin, *J. Opt. Soc. Am. B* **5**, 1134 (1988).
- [43] V.G. Gudelev and Y.P. Zhurik, *Quantum Electron.* **27**, 3 (1997).
- [44] V.G. Gudelev, L.P. Svirina, and Y.P. Zhurik, *Proc. SPIE* **2792**, 118 (1996).
- [45] C.O. Weiss and H. King, *Opt. Commun.* **44**, 59 (1982).
- [46] N.J. Halas, S.-N. Liu, and N.B. Abraham, *Phys. Rev. A* **28**, 2915 (1983).
- [47] R.S. Gioggia and N.B. Abraham, *Phys. Rev. A* **29**, 1304 (1984).
- [48] K. Lu, J. Wang, Z. Liu, G. Kao, and S. Chang, *Chin. J. Lasers* **A23**, 35 (1996) (in Chinese).
- [49] A.G. Akchurin, G.G. Akchurin, and L.A. Melnikov, *Proc. SPIE* **4243**, 75 (2001).
- [50] I.E. Zuikov, P.G. Krivitskii, A.M. Samson, and S.I. Turovets, *Sov. Tech. Phys. Lett.* **16**, 779 (1990).
- [51] P.W. Milonni, J.R. Ackerhalt, and M.L. Shin, *Opt. Commun.* **53**, 133 (1985).
- [52] M.L. Minden and L.W. Casperson, *J. Opt. Soc. Am. B* **2**, 120 (1985).
- [53] F.T. Arecchi, G. Giacomelli, A. Lapucci, and R. Meucci, *Phys. Rev. A* **43**, 4997 (1991).
- [54] F.T. Arecchi, G. Giacomelli, A. Lapucci, and R. Meucci, *Phys. Rev. A* **45**, R4225 (1992).
- [55] N.F. Rulkov, M.M. Sushchik, L.S. Tsimring, and H.D.I. Abarbanel, *Phys. Rev. E* **51**, 980 (1995).
- [56] H.D.I. Abarbanel, N.F. Rulkov, and M.M. Sushchik, *Phys. Rev. E* **53**, 4528 (1996).
- [57] L. Kocarev and U. Parlitz, *Phys. Rev. Lett.* **76**, 1816 (1996).