

Growth models and the question of universality classes

W. E. Hagston and H. Ketterl*

Department of Applied Physics, University of Hull, Hull, HU6 7RX, United Kingdom

(Received 23 June 1998)

In the past many papers have appeared which simulated surface growth with different growth models. The results showed that, if models differed only slightly in their “growth” rules, the resulting surfaces may belong to different universality classes, i.e., they are described by different differential equations. In the present paper we describe a mapping of “growth rules” to differential operators and give plausibility arguments for this mapping. We illustrate the validity of our theory by applying it to published results. [S1063-651X(99)05603-2]

PACS number(s): 68.35.Ct, 68.35.Dv, 68.55.-a

I. INTRODUCTION

During the past few years the kinetic roughening of surfaces has become a field of increasing interest. In particular, many papers have appeared concerned with computer simulations of surface growth (see, e.g., Ref. [1]).

In general, the surface is characterized by a height h appropriate to a d dimensional substrate of size L . The width of the surface $w(t, L)$ at a time t is characterized by $w(t, L) = \sqrt{\overline{(h)^2} - (\overline{h})^2}$ where the bar denotes an average. If the resulting surface is self-affine it can be represented by a dynamical scaling law,

$$w(t, L) \sim L^\alpha f\left(\frac{t}{L^z}\right), \quad (1)$$

where the function $f(x) \rightarrow \text{constant}$ for $x \rightarrow \infty$ and $f(x) \sim x^\beta$, with $\beta = \alpha/z$ as $x \rightarrow 0$. The unit of time corresponds to depositing L particles. For models which do not contain vacancies or overhangs, so-called solid on solid models (SOS), this means that the average height \overline{h} and the time t are identical. The exponents α , β , and z determine which universality class the given model belongs to. In the present paper we wish to examine the implications of some of the standard assumptions in the theory, and in particular to provide a mapping of prescribed rules of growth to the corresponding differential operators appearing in the associated stochastic growth equations.

II. THEORY AND DISCUSSION

A. Simple growth systems

The dynamical evolution of a surface prior to any movement of the deposited particles is presumed to be described by the equation

$$\frac{\partial h(x, t)}{\partial t} = F + \eta(x, t), \quad (2)$$

where η is a noise term with zero mean (i.e., $\overline{\eta} = 0$) and F is the flux rate of incident particles. For the particular case, usually considered in the literature, that F is a constant we obtain $\overline{h} = Ft$. The last result is only true if there are no vacancies in the system. A similar result (but with F replaced by a larger entity, F' say) would also hold, if the vacancy concentration stays constant over time, i.e., in this case we would again have $\overline{h} = F't$. However, for such a situation the starting equation would not be equal to Eq. (2), and $F' \neq F$, the incident flux. In general, the form of the starting equation for situations where vacancies and overhangs occur is far from obvious and is a problem we will return to later. Before we can answer such questions it is pertinent to address a far simpler problem. Namely, what type of deposition process is Eq. (2) applicable to anyway? One class of such processes is the so called SOS models in which particles are deposited randomly at lattice sites, i.e., a number is chosen at random and the number of particles at the site characterized by that number is increased by one. This is usually referred to as (pure) random deposition (RD) and corresponds to a constant flux F with a random noise term η . (We refer to it as pure since the deposited atoms are not permitted to move.) It is well known that the interface width for (pure) RD increases indefinitely with time, i.e., the associated surface is not self-affine with the consequence that the width itself does not saturate [1].

A variant of (pure) RD is to allow the particles to move after they have been deposited. Two types of movement are possible. One is “horizontal” movement in which the height of the moving particle does not change, and the other is vertical movement in which the height of the particle does change. With regard to the latter there are two possible types. One is upward vertical movement in which the height of the particle increases and the other is downward vertical movement in which the height of the moving particle decreases. In order to complete the rules of growth with regard to the “allowed” moves we need to specify the conditions under which horizontal or vertical movement is terminated. We will refer to these collectively as “sticking rules.”

In what follows we will show that what superficially appear to be “trivial” or “obvious” rules of movement (often designed for convenience of implementation on a computer) can have extremely subtle implications for the resulting mathematics (and, in particular, the associated differential

*Present address: Institut für Experimentelle und Angewandte Physik, Universität Regensburg, 93040 Regensburg, Germany. Electronic address: hermann.ketterl@physik.uni-regensburg.de

equations purporting to model the resulting surface structure). Furthermore, we will show that the implications for the mathematics (even for the same set of rules) can be different dependent on the dimensionality of the surface d' under consideration.

We examine a $d'=1$ surface, i.e., a two-dimensional structure ($d=2$) having a y axis (the height) and an x axis (the coordinate defining the position along the surface). A possible set of rules is the following. Permit the particle to be displaced horizontally up to a maximum of l lattice sites provided always that there is another particle immediately below it. If such a situation always prevails, then at the end of the l moves leave the particle where it is. If, on the other hand, in the course of making these moves the particle encounters a gap, then allow it to move vertically down until it reaches a position where there is again a particle immediately below it at which point the particle movement is terminated. Similarly, if in the course of making up to l moves, it meets another particle on the same level all movement is terminated.

It is clear that surface relaxation processes involving such SOS movements have the effect of changing the noise term η in Eq. (2) to a new value η' . Thus this situation could be described by the equation

$$\frac{\partial h}{\partial t} = F + \eta'. \quad (3)$$

Such an equation, although correct, is of little use from an analytical viewpoint because we do not know the form of the noise term η' . However the essential characteristic of SOS movement that we can make use of is that it leaves the average height of the surface unchanged. In effect one lattice site loses a particle and another lattice site (which could be anywhere up to a distance l away horizontally) gains one. This suggests that we write the noise term η' in the form

$$\eta' = \eta + \frac{\partial G}{\partial x}, \quad (4)$$

where G is any (well-behaved) function we care to choose. The reason being that the act of averaging over a finite (but large) number of discrete particles is deemed as being equivalent (in a continuum description) to the act of integrating and then dividing by the “length” of the region of integration. Consequently, expressing the change in the noise as a divergence means (at least in the limit that the length of the system becomes infinite) that the average of η' is zero (just like η). This then gives the formal result

$$\bar{h} = \langle h \rangle = Ft,$$

which is known to be correct for SOS models. (One might note that, strictly speaking, this result is not “exact” for a finite system since the divergence term integrates to a small but finite entity. Such “errors” are an inherent feature of the modeling of finite systems by continuum differential equations.) Thus, for SOS models invoking “surface relaxation” we expect the generalization of the equation of motion Eq. (2), for (pure) RD to be

$$\frac{\partial h}{\partial t} = F + \frac{\partial G}{\partial x} + \eta, \quad (5)$$

where G is, at this stage, some unspecified function. A computer model of $d'=1$ RD plus surface relaxation was evaluated by Family [2] many years ago. According to this author the resulting surface was self-affine, i.e., was described by Eq. (1) with the value of the parameters α , β , and z being independent of the maximum number of lattice sites l over which a particle was allowed to move horizontally (a point we will return to later). Furthermore Family [2] found that the scaling properties of the surface (or equivalently, the values of α , β , and z) were consistent with the choice

$$G = \nu \frac{\partial h}{\partial x} \quad (6)$$

with ν constant.

The resulting equation,

$$\frac{\partial h}{\partial t} = F + \nu \frac{\partial^2 h}{\partial x^2} + \eta, \quad (7)$$

is well known in the literature and is referred to as the Edwards Wilkinson (EW) equation [3]. It is important to note exactly how the mapping of the horizontal and vertical motion onto a differential operator occurs in Eq. (7). The entity $\nu(\partial^2 h/\partial x^2)$ (with ν positive) corresponds (as shown in Fig. 1) to a movement of particles from the top of a “hill” to the bottom of it, i.e., a flattening of the hill. In other words it is consistent with movements both horizontally and vertically downwards. This manifests itself clearly in that model of Family [2] in which all possible downwards moves of a particle are allowed to occur, and the particle moves to the nearest-neighbor position only in the horizontal movement (i.e., $l=1$). The form of the associated surface is shown in Fig. 2. Examination of the latter shows that the “vertical” separation of nearest-neighbor columns is also small for this situation. Hence the model leads self-consistently (as a result of the rules of movement) to a situation where both small horizontal and downward vertical motion is the norm. Thus the situation where all possible downward motion is permitted to occur with 100% probability is replicated in the mathematics by the differential form $\nu(\partial^2 h/\partial x^2)$ (Fig. 3).

This having been established we now return to the claim by Family [2] that the parameters α , β , and z are independent of the magnitude of l . To see that this cannot possibly be true let us take a $d'=1$ surface of length L and allow the number of horizontal moves to be up to a maximum of L . For such a situation it is clear that we will obtain layer by layer growth—the reason being the following. During the first monolayer coverage “islands” will develop of size L_i say. With increasing coverage it becomes increasingly probable that the next particle added will be on one of these islands. However, if the particle is allowed L horizontal moves, it will migrate readily to the edge of the island, go over the side and then adhere to the rim of it, thus extending the size of the island. There are several important results to be deduced from these considerations. First, if we have a surface of total length L , then as long as we allow horizontal moves up to some maximum l say, we may well find a series

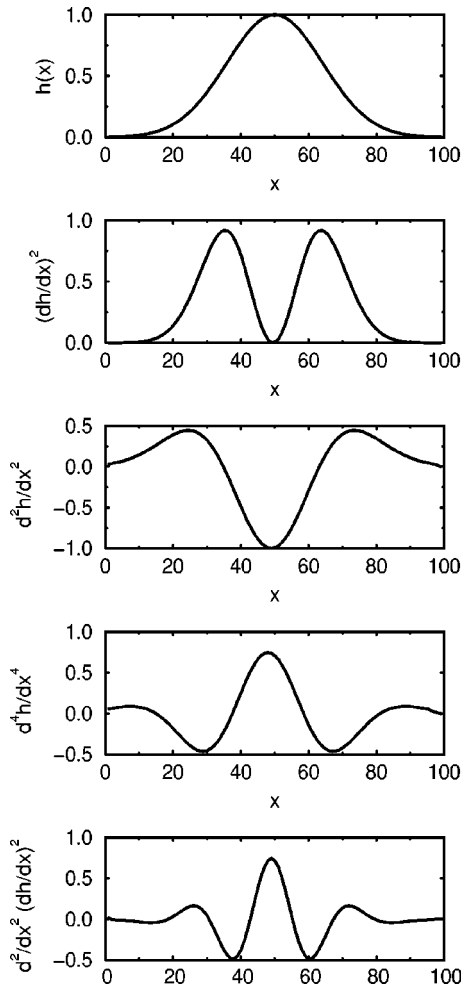

FIG. 1. Differential operators acting on the function $h(x)$. $[(\partial h/\partial x)]^2$ increases the particles at the side of the hill but does not transport them to the top of it. $+(\partial^2 h/\partial x^2)$ removes particles from the top of the hill and redistributes them to the sides and bottom of it. $-(\partial^4 h/\partial x^4)$ is similar to the previous case. $+(\partial^2/\partial x^2)(\partial h/\partial x)^2$ moves particles from the base of the hill to the top of it.

of surfaces belonging to the same universality class. However, this can only be true as long as l is less than some fraction of the total ‘‘length’’ L of the surface. Once l exceeds this fraction, an increasing number of islands will coalesce and we will very quickly obtain layer by layer growth. In short, dependent on the size of the system, universality classes will only be obtained if we permit a limited number of horizontal movements only. The precise number is ill defined at this stage, but typically in the literature this number is chosen to be 1 or 2 only.

B. Surface relaxation involving vertical motion downwards only

We consider next vertical motion and, in particular, (pure) ballistic deposition (BD). In such a model one imagines the particles being deposited vertically onto a substrate in a random sequence. The rule of movement is to move vertically down until the particle meets another particle. The latter can be either directly underneath or at the side of the moving particle. In either event movement is then terminated. As is

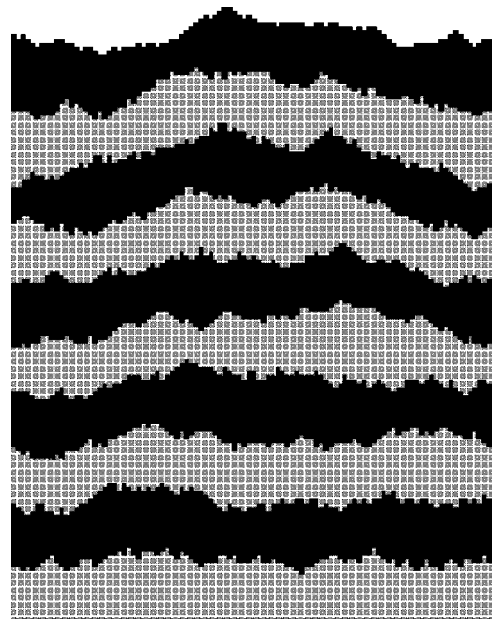

FIG. 2. Surface for RD plus relaxation after Family (taken from Ref. [1]).

well known, such a model does have overhangs and vacancies present in it. Consider next (pure) BD plus surface relaxation. The specification of the latter is the following. If there is another particle immediately beneath the one under consideration then no movement occurs. On the other hand, if there is no particle immediately beneath the one under consideration move the latter down until it comes into contact with either the substrate or another particle which lies immediately below it. At this point motion ceases. In other words we are looking at a model of BD plus surface relaxation where the latter is defined to be vertical movement downwards. At this stage the extent of the movement downwards is ill defined. It is obvious that such a model of BD plus vertical movement downward gives us exactly the same end result as (pure) RD. Hence the equation of motion for BD plus vertical movement downward (or pure RD) is Eq. (2). However, the interface width for such a situation increases without limit and hence, after an infinite time, the width is infinite. Correspondingly the vertical movements downward must be infinite. What this shows us is that when we define the rules of movement for BD plus vertical relaxation, we have no idea of the extent of the vertical movement. However, the model, when evolved self-consistently according to these same rules, shows us that the motion in

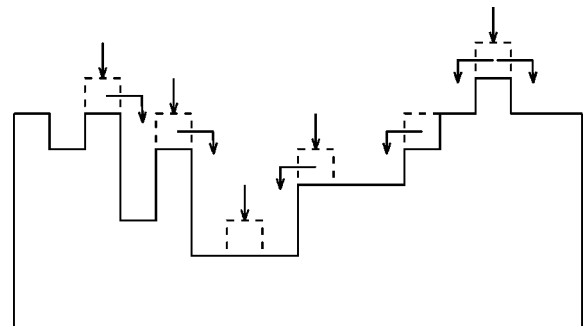

FIG. 3. Growth rules of Family.

the vertical direction is unlimited. Furthermore, although vertical movement is occurring, the equation of motion, i.e., Eq. (2), does not contain any differential operators, the structure itself is free of vacancies and the surface is not self-affine.

1. Surface relaxation involving vertical motion upwards only

Let us consider next a variant on this model but this time involving upward motion. In essence, the previous model started from (pure) BD allowed vertical motion downwards and ended up with (pure) RD. We will now consider the converse, i.e., we will start with (pure) RD allow vertical motion upwards and end up with (pure) BD. Thus the rules of motion are the following. Choose a random number and add one particle to the corresponding lattice point. If the added particle has no neighboring points occupied by particles to a higher level, then leave it where it is. On the other hand, if the added particle finds higher columns next to it, move it up the side of the highest such column until it is level with the top most point. Again at this stage we have no idea of the extent of the upward motion that will ultimately be involved in such a model. It is well known of course that (pure) BD, which is in essence the model we are describing, leads to a surface width which ultimately saturates. In turn this means that the upward motion is in fact finite and determined by the surface width. Furthermore, the associated equation of motion for the surface is well known. However we deliberately refrain from writing it down at this stage for reasons that will be apparent later. Suffice it to say that our original starting point was (pure) RD for which the equation of motion is Eq. (2). We then included what turns out to be finite upward motion. The latter can, apparently, be described by adding two differential operators to Eq. (2). One of these turns out to have the same form as that given in Eq. (7). However the other cannot be written as a divergence term, i.e., it is a nonconservative term and is in fact represented by a nonlinear operator.

Another interesting aspect of these two cases is the following. At the outset it is not apparent in either model just what the extent of the vertical motion is. However, the models themselves evolve in such a way that the downward vertical motion is unlimited in extent whereas the upward vertical motion is limited. This shows that the rules of movement, which appear to be the “mirror image” of one another, lead to models which evolve in such a way that up-down symmetry in the growth direction is broken, i.e., motion downwards can occur to a significantly greater extent than motion upwards.

2. Surface relaxation involving limited vertical motion downwards only

When considering horizontal movement, we argued that the existence of universality classes, associated with surface relaxation processes, was in fact a consequence of the limited amount of horizontal movement that was permitted to occur. We will now examine the corresponding question of imposing a limited amount of vertical movement downwards. Thus we begin with a model which initially starts from (pure) BD and then allows a limited number of vertical moves downward (i.e., a maximum of 100 lattice spacings say). Initially, when “growing” such a model on the computer, we will be

dealing with essentially pure RD. This is because the interface width in the early stages of growth will be much less than 100 lattice spacings. Hence initially we will have a SOS pure RD growth mode in which there are no vacancies present in the structure. For this stage of the growth the governing equation will be Eq. (2). However, as we know, the interface width grows without limit for (pure) RD and a stage will eventually be reached at which the interface width approaches and then exceeds 100 lattice spacings. Once this occurs a situation will develop where some of the downward vertical motion will leave vacancies in the structure, i.e., some of the downward motion will not be SOS. For such a situation we would expect from our earlier considerations that the form of the equation of motion would change and, by analogy with the previous case, we might anticipate nonlinear terms to appear in it. The hybrid nature of the present case from the earlier viewpoint of describing (pure) BD starting from (pure) RD is that only some of the particles having higher columns next to them are eventually moved up, and even then they are only moved part of the way up the column.

The essential point here is the following. We started from a model with well defined rules of movement. In the early stages of growth, the resultant structure was defect free (i.e., no vacancies) and was described by a particular equation. However, as a self-consistent result of the rules of movement, the surface eventually evolves according to a different differential equation from the one describing the earlier stages of growth. During the second stage of growth defects (i.e., vacancies) do occur in the structure and the resulting equation would be anticipated to contain nonlinear terms. It is important to stress that it is *not* the case that the equation of motion is the same throughout all the growth, but with a cross-over from one regime of dominance to another regime. Rather different forms of equation are required to describe the evolution of the different stages of growth. What is more, if we increased the maximum number of allowed downwards vertical moves from 100 to, say, 1000, the time during which the first growth stage was governed by pure RD would increase correspondingly. This shows clearly that the “cross-over” time between the two regimes is governed by the number of vertical moves that are permitted to occur. Given that (pure) RD is not a self-affine surface, we can see that in general whether such a surface (i.e., self-affine) is ever seen to evolve in a finite time computer model can be crucially dependent on the nature and extent of the permitted movements.

C. Heuristic rules

As a prelude to describing the proposed rules we consider a simplified model that permits some insight into this question. Consider first pure random deposition in one dimension and the question of the change in the interface width following the deposition of one monolayer. The expression for the final height $\langle h \rangle_f$ reads

$$\langle h \rangle_f = \frac{1}{L} \left(\sum_i (h_i + 1 + \eta_i) \right) = \langle h \rangle_i + 1, \quad (8)$$

where $\langle h \rangle_i$ is the initial average height and L the length of the substrate.

Similarly,

$$\langle h^2 \rangle_f = \frac{1}{L} \left(\sum_i (h_i^2 + 2h_i + 1) + 2\eta_i(h_i + 1) + \eta_i^2 \right),$$

i.e.,

$$\langle h^2 \rangle_f = \langle h^2 \rangle_i + 2\langle h \rangle_i + 1 + \langle \eta_i^2 \rangle. \quad (9)$$

It follows from Eqs. (8) and (9) that the final interface width w_f is related to the initial interface width w_i by the relation

$$w_f^2 = \langle h^2 \rangle_f - \langle h \rangle_f^2 = w_i^2 + \langle \eta_i^2 \rangle. \quad (10)$$

If we now imagine a relaxation process occurring involving the movement of particles downwards in which a fraction α of the columns lose a particle and a fraction α of them gain one, a similar analysis leads readily to the result

$$w_f^2 = w_i^2 + \langle \eta_i^2 \rangle + 2\alpha + 2\alpha[\langle h_i \rangle_g - \langle h_i \rangle_L], \quad (11)$$

where $\langle h_i \rangle_g$ ($\langle h_i \rangle_L$) is the average height of the columns that gain (lose) a particle. It follows from Eq. (11) that saturation will occur if the following relation is obeyed:

$$\langle h_i \rangle_L - \langle h_i \rangle_g = \frac{1}{2\alpha} \langle \eta_i^2 \rangle + 1. \quad (12)$$

Since the noise term (i.e., $\langle \eta_i^2 \rangle$) is fixed it is clear that it will be difficult, in general, to satisfy this equation on a layer by layer growth basis and that in general large fluctuations (or oscillations) about the ‘‘equilibrium’’ width will occur in computer simulations on finite size substrates. Another important feature that is apparent from examination of Eq. (12) is the following. If, within a class of allowed moves, we permit only a fraction β of any given move to occur, we would replace α by the fraction $\alpha\beta$. This means that the entity on the left hand side of Eq. (12) would increase progressively as we decreased the value of β . In turn this implies that the corresponding interface width would increase. Since allowed moves of a given class are presumed to be associated with a universality class of a particular type, this implies that the interface width of the latter can be increased continuously simply by reducing the probability of movement uniformly for all allowed moves in the class (clearly the range of possible values of β , although undefined at this stage, cannot be over the entire region $0 \leq \beta \leq 1$ since, e.g., $\beta=0$ gives the model involving no relaxation, i.e., exactly how small β can be is not known at this stage). Put alternatively, this suggests that interface width alone is a poor indicator of the universality class since the prefactor of the term describing the time evolution of this width for such a class can be increased by simply varying the probability of occurrence of all allowed moves in the class. It is revealing to pursue this argument further and to distinguish between the various types of move contained within a given class of moves. This can be done on the basis of the coordination number v_i of the particle prior to movement. For example, in the case of $v_i=1$ we could distinguish between the fraction of particles α_1 having a $v_i=1$ and sat on top of a column, from the fraction α_2 having a $v_i=1$ and sat next to a step

edge. Yet again these are to be distinguished from the fraction α_3 of particles having a $v_i=2$. For generality we will assume that the fraction of particles are α_1 up to α_n . [In terms of the previous notation ($\alpha = \alpha_1 + \alpha_2 + \dots + \alpha_n$)]. The generalization of Eq. (11) can be readily shown to be

$$\begin{aligned} w_f^2 = & w_i^2 + \langle \eta_i^2 \rangle + 2\alpha + 2\{\alpha_1[\langle h_i \rangle_g - \langle h_i \rangle_L] \\ & + \alpha_2[\langle h_i \rangle_{2g} - \langle h_i \rangle_{2L}] + \dots \\ & + \alpha_n[\langle h_i \rangle_{ng} - \langle h_i \rangle_{nL}]\} \end{aligned} \quad (13)$$

where, in an obvious notation $\langle h_i \rangle_{ng}$ ($\langle h_i \rangle_{nL}$) is the average height of type n columns that gain (lose) a particle. Once again the effect of reducing all the α_i by the *same* factor β will give the immediate generalization of the result described earlier. However, it is clear from the present equation that the functional form of the equation remains unchanged only when all the α_i are reduced in this way. As opposed to this, if the α_i are all reduced by different factors β_i , then the functional form of the equation is changed. For such a situation it is far from obvious whether the resultant class of moves belongs to the same universality class as for $\beta=1$ (or for a uniform value of β). In the extreme case that $\beta_i=0$ for some of the moves, but exists for others, we would clearly anticipate a different universality class. However, even for the latter situation, it is not clear whether increasing the β_i values that were previously identically zero to extremely small values would change the universality class type, i.e., the stability of the latter to small changes of movement type is not presently known.

D. Heuristic arguments for the differential operators appearing in the stochastic differential equation

We form next a set of rules for which differential operators are to be associated with which situation (see also Fig. 1). In the latter, following conventional wisdom, we have considered four types of differential operators only namely, $(\partial h/\partial x)^2$, $\partial^2 h/\partial x^2$, $(\partial^2/\partial x^2)(\partial h/\partial x)^2$, and $\partial^4 h/\partial x^4$. (As should be clear from Fig. 1 the effect of such operators on a ‘‘symmetric hill’’ is symmetric—hence as long as the prescribed rules of deposition and surface relaxation possess this left—right symmetry one would expect such even order operators.)

Our suggested rules are the following.

For surfaces whose interface width saturates:

(i) For movement vertically downwards (further refinement of these rules are presented later) (1) employ the operator $+\nu(\partial^2/\partial x^2)$ if the rules of movement include all possible downward motion, (2) employ the operator $-\kappa(\partial^4/\partial x^4)$ if the rules of movement exclude certain $v_i=2$ particles.

(ii) For movement vertically upwards (further refinement of these rules are presented later) (1) employ the operator $+\gamma(\partial h/\partial x)^2$ if the rules of movement involve the creation of vacancies in the structure and correspond to maximal movement (with 100% probability) of particles up the side of columns but do *not* involve movement to the top of the adjacent column (i.e., non-SOS models), (2) employ the operator $\lambda(\partial^2/\partial x^2)(\partial h/\partial x)^2$ if the rules of movement do not involve the creation of vacancies in the structure and

correspond to the movement of particles (with 100% probability) upward from the top of one column to the top of an adjacent column (i.e., SOS models). Note that upwards motion can, on its own, destabilize a surface, and for SOS relaxation needs to be counterbalanced by an equivalent downwards motion “current.”

For surfaces whose interface width does not saturate there are at least two distinct possibilities. Either the growth equation does not contain differential operators (e.g., pure RD or, as we will argue in a later paper, pure shading) or it contains an instability.

It should be clear from our earlier discussions that instabilities can be induced in a given model by reversal of the motion in surface relaxation processes. Such time reversal has the effect of, e.g., replacing ν by $-\nu$ in Eq. (7). Clearly reversing the sign of the four differential operators we discussed earlier could therefore result in instabilities in the associated differential equation. Hence one has to examine carefully the permitted movements in order to ensure that such movements do not ultimately lead, via self-consistency, to terms in the associated differential equation, which makes its solution unstable. An example of this is given later.

E. Comparison of the heuristic rules with computer models reported in the literature

Most computer models reported in the literature permit the deposited particle one move in the horizontal direction. Which direction the particle moves vertically is also determined by the rules of movement. In certain cases both upward and downward motion is permitted, whereas in other cases upward (or downward) motion only is permitted. For many cases reported in the literature the rules governing surface relaxation (which are almost invariably of the SOS type) are not even stated in this simple form, rather, in an effort to mimic the physics, the rules are defined in terms of the coordination number ν_i of the particle to be moved. In particular, when $\nu_i \geq 2$ movement is not usually permitted unless the coordination number increases—i.e., in those situations where the coordination would be the same at the end of the movement as it was prior to movement (the so-called “tie” situation) no movement is permitted. On the other hand where the coordination number increases via the movement, the rule could either be (a) move to the nearest-neighbor site that increases the value of ν_i or (b) move to the nearest-neighbor site which gives the maximum value of ν_i .

The subtlety of these rules is that, because of the topology of the surface, (a) and (b) define different types of allowed moves in different dimensions. For example, Kotrla, Levi, and Smilauer [4] have shown that both (a) and (b) lead to vertical motion downwards in $d' = 1$. However, in $d' = 2$ rule (a) leads to predominantly downward motion whereas rule (b) leads to both downward and appreciable upward motion.

We will now consider various models from this viewpoint. For the well known $d' = 1$ case studied by Family [2] the tie situation occurs frequently for $\nu_i = 2$ and the rules of movement permit the particle to move down only under these circumstances. Correspondingly the resulting interface is smooth—hence we are led to the conclusion that if all moves downward are permitted (including the tie situation)

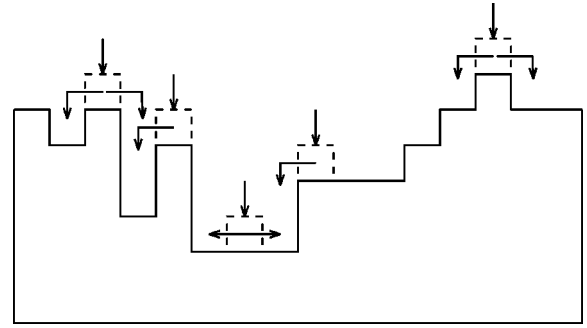

FIG. 4. Growth rules of Wolf.

the resulting interface is smooth and the associated relaxation downward is described by the operator $\nu(\partial^2 h / \partial x^2)$. As opposed to this it is found that if, in $d' = 1$, moves downwards for the tie situation when $\nu_i = 2$ are forbidden (Figs. 4 and 5) and downward motion only allowed if the coordination number is increased, we obtain a rough interface (Fig. 6 the properties of which are described by the operator $-\kappa(\partial^4 h / \partial x^4)$ [5,6]. The generalization of these same rules to $d' = 2$ presents an interesting situation in that for case (a) discussed above, this leads to predominantly downward motion only and is hence described by the operator $-\kappa(\partial^4 h / \partial x^4)$ [5,6]. However, for case (b), significant upward motion is also allowed which is essentially SOS in nature. The corresponding interface (which is rough) will be described by an equation in which the downward motion is represented by the operator $-\kappa(\partial^4 h / \partial x^4)$ whereas the upward motion is described by $\lambda(\partial^2 / \partial x^2)(\partial h / \partial x)^2$. This is in agreement with what is found in the computer modeling [4,7]. Hence we here have a situation where the equation of motion, because of the permitted rules of movement, is governed by the following equation:

$$\frac{\partial h}{\partial t} = F - \kappa \frac{\partial^4 h}{\partial x^4} + \eta \quad (14)$$

in $d' = 1$, but is described by the equation

$$\frac{\partial h}{\partial t} = F - \kappa \frac{\partial^4 h}{\partial x^4} + \lambda \frac{\partial^2}{\partial x^2} \left(\frac{\partial h}{\partial x} \right)^2 + \eta \quad (15)$$

in $d' = 2$. We would argue, in contrast with statements in the literature [4] that this is not an unusual situation in physical terms but is merely a consequence of the fact that the permitted movements in $d' = 1$ and $d' = 2$ are different. Equally

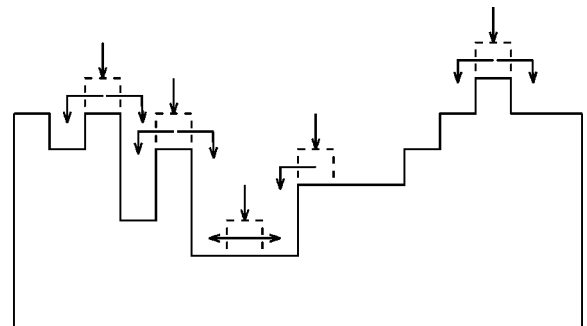

FIG. 5. Growth rules of Das Sarma and Tamborenea.

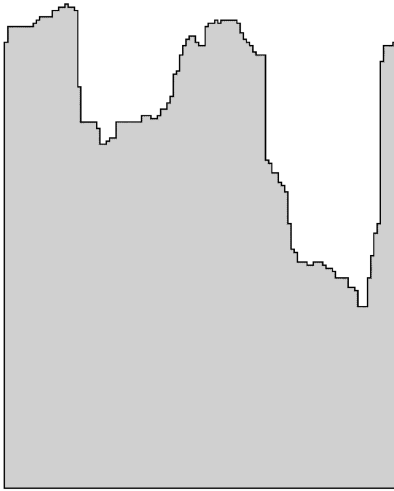

FIG. 6. Surface of the Wolf and Villain model (taken from Ref. [1]).

we would argue [1] that it is not true that the equation of motion is the same in $d' = 1$ and $d' = 2$ but that the crossover has not been seen in $d' = 1$.

Consider next the model of Lai and Das Sarma [8]. These authors considered a similar model in $d' = 1$ to the one of Wolf and Villain [5] and Das Sarma and Tamborenea [6]. However, in the case of tie with $v_i = 2$ the particle was moved to the nearest neighbor site with the smaller height difference (i.e., sometimes upwards and sometimes downward motion occurred). For the case of a tie with $v_i = 1$ the particle was allowed to diffuse to higher bonding within a distance l —i.e., for $d' = 1$ downward motion could also occur for this situation. Given that these rules are all SOS type and that significant amounts of upward and downward motion is occurring, we would expect that the resulting equation is the fourth-order nonlinear equation appearing in Eq. (15). This is precisely what Lai and Das Sarma [8] found.

In view of our earlier comments we would envisage an interesting situation developing if, in the case of tie with $v_i = 2$, the downward motion was forbidden and only the upward motion was allowed. For such a situation we could anticipate an instability could develop in the system since such upwards motion is not counterbalanced by an equivalent downwards motion “current.” This is precisely what happens in the model of Park, Provata, and Redner [9] where no saturation of the interface width was found for systems larger than a critical size.

As a final example we consider model 1 in $d' = 2$ of Kotrla, Levi, and Smilauer [4]. This model is a straightforward generalization of the Wolf and Villain [5] and Das Sarma and Tamborenea [6] model in that if there is a neighboring site with a higher value of v_i the particle relaxes to it in either the upward or the downward direction. In the case of a tie the particle remains where it is. It should be obvious from our previous discussion that once again we have SOS relaxation in the upward and the downward direction and that the fourth order nonlinear equation, i.e., Eq. (15) will describe the evolution of the surface. This is exactly what Kotrla, Levi, and Smilauer [4] found.

Given the success of our heuristic rules we could then invert the problem of predicting the permitted movements to

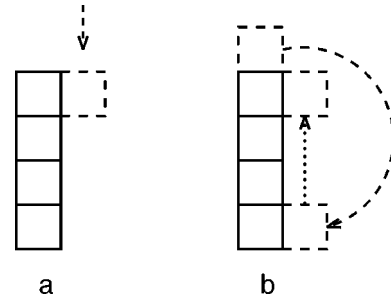

FIG. 7. Different rules with the same result.

be associated with a given stochastic differential equation. Consider, for example, the equation

$$\frac{\partial h}{\partial t} = F + \nu \frac{\partial^2 h}{\partial x^2} + \gamma \left(\frac{\partial h}{\partial x} \right)^2 + \eta. \quad (16)$$

The terms $F + \eta$ imply that the initial deposition is SOS and is pure RD. The second term represents movements horizontally and vertically downwards. Similarly the term $(\partial h / \partial x)^2$ implies relaxation vertically upwards with the particle being moved up the side of a column until it was (at most) placed level with the top of it (i.e., non-SOS vertical motion, which creates vacancies in the system). In summary, we would expect that Eq. (16) represented RD followed by surface relaxation in which the process involves both downward and upward motion. It comes as somewhat of a surprise therefore to find that Eq. (16) is apparently applicable in $d' = 1$, to pure BD. If anything we might have expected that the latter corresponds to (pure) RD followed by limited vertical movement upwards along the side of higher (neighboring) columns—i.e., one might have expected (pure) BD to have obeyed the equation

$$\frac{\partial h}{\partial t} = F + \gamma \left(\frac{\partial h}{\partial x} \right)^2 + \eta.$$

A possible resolution of this paradox would be (as indicated by our previous reasoning) that (pure) RD followed by surface relaxation in both the downward and upward direction is mathematically indistinguishable from pure BD. This problem will be addressed in future publications. For the present we note that, in graphical terms, what we are suggesting is that the situation depicted in Fig. 7(a) (appropriate to “pure” BD) is ultimately physically indistinguishable from that depicted in Fig. 7(b), i.e., RD plus surface relaxation in the downward and upward direction. Alternatively we could argue that we need both a downward and an upward current of particles to obtain a stable interface.

III. CONCLUSION

In the present paper we have presented arguments to the effect that observation of universality classes in computer simulations of surface growth is a consequence of the limited number of horizontal moves that a given particle is permitted to make. (Conversely, if the particle was permitted to make any number of moves up to a maximum value determined to be equal to the substrate size, then interface roughness would never develop in the sense that growth would be of the layer

by layer type.) Given the limited number of horizontal moves, the universality class is then determined by the nature and extent of the vertical motion. This ultimately is controlled by the rules associated with the coordination number v_i taken in conjunction with the dimensionality d' of the surface. In particular, rules may be defined that in effect allow, for example,

(a) downward motion only in both $d' = 1$ and $d' = 2$ or
 (b) downward motion in $d' = 1$ but both downward and upward motion in $d' = 2$.

If downward motion only is allowed and this is of the SOS type (i.e., a particle has another particle beneath it at the beginning and end of the motion) then the degree of the differential operator, i.e., $\partial^2 h / \partial x^2$ or $\partial^4 h / \partial x^4$ is determined by the rules of motion associated with the tie situation. If motion downwards is allowed in the tie situation, then the second order differential operator is appropriate since this corresponds to all moves downwards being permitted. On the other hand, if motion downwards is forbidden in the tie situation, then the fourth order differential operator is applicable since such an operator is appropriate for the situation where only a fraction of the moves that can occur are permitted to occur. Similarly, if both upward and downward motion is allowed in the tie situation the fourth-order equation is again applicable.

In the case of upward motion the form of the differential

operator will again be determined by the rules of movement. If the upward motion is of the SOS type then it is described by the operator $\partial^2 / \partial x^2 (\partial h / \partial x)^2$. However if it is non-SOS type (i.e., it leads to the creation of vacancies) it will be described by the operator $(\partial h / \partial x)^2$.

We have shown, in the body of the text, that these heuristic rules are consistent with many standard results reported in the literature. Furthermore we have presented arguments to show that the nature and extent of the permitted vertical motion can lead to situations where, for example, initially the growth contains no vacancies and is described by a particular differential equation. However, eventually vacancies will enter the structure (as a result of the rules of movement) and subsequently for this situation, the growth is described by a different differential equation.

Further substantiation for the validity of these arguments will be presented in a series of subsequent papers where we will also address the question of the apparent anomaly of the equation of motion for pure BD, and the question of the universality class when the β_i is chosen to have different values for the different move types i .

ACKNOWLEDGMENT

H. K. is very grateful for the support of the Hans Böckler Stiftung.

-
- [1] L. Barabasi and H. E. Stanley, *Fractal Concepts in Surface Growth* (Cambridge University Press, Cambridge, 1995).
 [2] F. Family, *J. Phys. A* **19**, L441 (1986).
 [3] S. F. Edwards and D. R. Wilkinson, *Proc. R. Soc. London* **381**, 17 (1982).
 [4] M. Kotrla, A. C. Levi, and P. Smilauer, *Europhys. Lett.* **20**, 25 (1992).
 [5] D. E. Wolf and J. Villain, *Europhys. Lett.* **13**, 389 (1990).
 [6] S. Das Sarma and P. Tamborenea, *Phys. Rev. Lett.* **66**, 325 (1990).
 [7] S. Das Sarma and S. V. Ghaisas, *Phys. Rev. Lett.* **69**, 3762 (1992).
 [8] Z. W. Lai and S. Das Sarma, *Phys. Rev. Lett.* **66**, 2348 (1991).
 [9] H. Park, A. Provata, and S. Redner, *J. Phys. A* **24**, L1391 (1991).