

## Nature of the smectic-*A*–hexatic-*B*–crystal-*E* transitions in extremely thin films determined by optical reflectivity measurements

T. Stoebe and C. C. Huang

*School of Physics and Astronomy, University of Minnesota, Minneapolis, Minnesota 55455*

(Received 12 November 1993; revised manuscript received 28 February 1994)

Employing high-resolution optical reflectivity measurements, we have investigated the nature of the smectic-*A*–hexatic-*B*–crystal-*E* transitions in extremely thin *n*-alkyl-4'-*n*-alkoxybiphenyl-4-carboxylate (*nm*OBC) films. The reflectivity data are shown to yield quantitative information on the molecular density of the films. The experimental technique has been found to be extremely powerful in establishing the continuous nature of the smectic-*A*–hexatic-*B* transition.

PACS number(s): 64.70.Md, 61.30.-v, 64.60.Kw

### I. INTRODUCTION

The study of dimensionally constrained systems has been of increased interest in recent years and the theories regarding melting in two dimensions have generated quite a large body of important literature. Many experimental systems have subsequently been developed to test these theoretical predictions and explore the interesting phenomena observed. One of the richest such systems has proven to be that of liquid crystals in the free-standing film geometry. In the appropriate temperature range and mesophase, many liquid-crystal compounds can be spread across an opening to form freely suspended films, like soap films. Since stable, uniform films can be created as thin as two molecular layers in thickness ( $\approx 50$  Å), they are well suited for the study of physics in two dimensions. Moreover, their free-standing nature avoids many of the serious problems associated with sample-substrate coupling.

A number of other experimental probes have been applied to examine these free-standing films. High resolution x-ray and electron-beam scattering studies have been performed allowing the structural identification of many mesophases [1,2]. Light-scattering experiments have provided insight into the elastic properties of the films [3]. Mechanical measurements have been conducted to probe the shear mechanical response of the two-dimensional solid phase [4]. Calorimetric studies have shed light on their thermal properties [5], etc. In this paper, we describe a relatively simple, high-resolution, optical reflectivity experiment that yields quantitative data on the molecular density of extremely thin free-standing liquid-crystal films as a function of temperature. This experimental technique has allowed us to significantly improve our temperature resolution and conclude that the smectic-*A*–hexatic-*B* transition in two-layer 3(10)OBC films is continuous to within only 2 mK.

### II. EXPERIMENTAL SETUP

The films [6,7] are created inside a sealed two-stage oven backfilled with  $\frac{1}{2}$  atm of pure argon gas by the motion of a glass spreader across a 1 cm square opening

in a stainless steel film plate (see Fig. 1). The temperature of the oven is computer controlled and has been found to be stable to better than 1 mK. Details of the oven construction have been described in Ref. [7]. Optical access is provided through quartz windows tilted  $10^\circ$  relative to the plane of the film to eliminate interference and multiple reflections off the film. A model 117A Spectra Physics 1-mW polarized He-Ne laser operating at 638 nm and in its amplitude-stabilized mode is used as the light source. The laser is mounted in an Al enclosure to further reduce drifts in laser power output due to thermally induced fluctuations of the lasing cavity. Employing standard ac techniques, the laser beam is mechanically chopped at 675 Hz. A variable neutral density filter is used to insure optimal performance of the photovoltaic detectors (Model PIN-10DP, United Detector Technology). A small portion of the beam is split off to monitor laser power intensity while the majority of the beam is directed to intersect the film at near normal incidence ( $\theta_i < 7^\circ$ ). The intensities of the laser light reflected off the film and of the monitor beam are detected using similar photovoltaic cells and a lock-in amplifier (Model 124 A, Princeton Applied Research). A rotating polarizer is mounted in front of the monitor photovoltaic cell so its

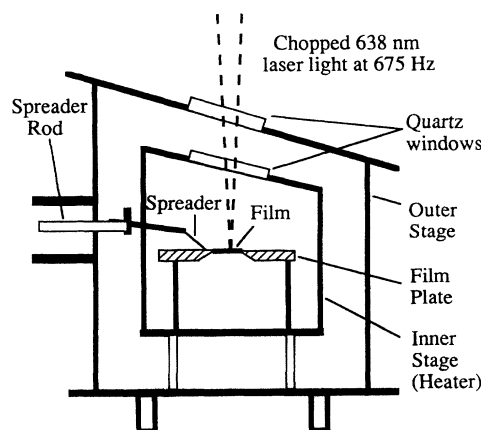

FIG. 1. Oven schematic.

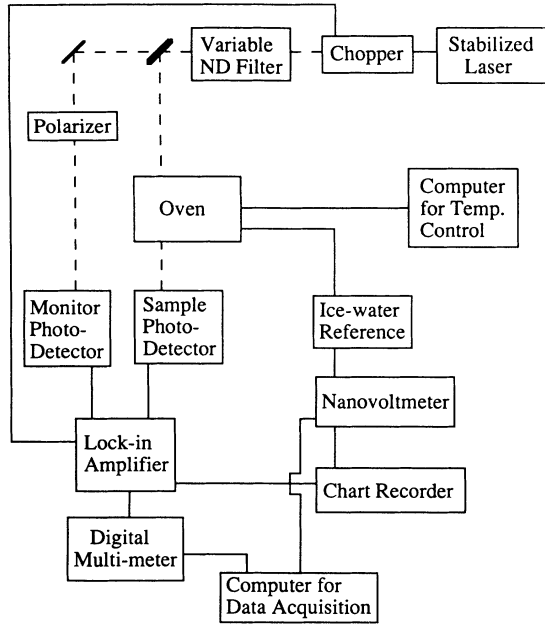

FIG. 2. System schematic.

signal level can be adjusted to greatly reduce the effects of residual laser power fluctuations by operating the lock-in amplifier in the differential mode between the film and monitor signals. The system typically operates at over 98% subtraction yielding reflectivity data with a signal-to-noise ratio better than  $5 \times 10^4$ . The system schematic is shown in Fig. 2.

### III. MEASUREMENT RESULTS AND DATA ANALYSES

The orthogonal smectic films exist as quantized stacks of single molecular thick layers in which the long axis of the molecules are parallel to the layer and film normals [8]. Because the molecules are highly anisotropic ( $25 \times 6 \times 3 \text{ \AA}^3$ ), many liquid-crystal phases are optically biaxial. However, since the molecules may exhibit collective rotation about their long axes in both the smectic-*A* (Sm-*A*) and hexatic-*B* (Hex-*B*) phases, free-standing films of these phases may be treated simply as uniform uniaxial dielectric slabs over the  $100\text{-}\mu\text{m}$  spot size of the illuminating laser. The reflectivity for light polarized perpendicular to the plane of incidence on such a slab is given by [9]

$$R = \left[ \frac{4n_0^2 \cos^2(i) \cos^2(r)}{[\cos^2(i) - n_0^2 \cos^2(r)]^2 \sin^2(a)} + 1 \right]^{-1}, \quad (1)$$

where  $i$  is the angle of incidence,  $r$  is the angle of reflection,  $n_0$  is the ordinary component of the index of refraction of the slab, and  $a = n_0 h k \cos(r)$ . The thickness of the slab is given by  $h$  and  $k$  denotes the wave vector of the incident beam ( $k = 9.93 \times 10^{-4} \text{ \AA}^{-1}$ ). Taking  $h = N\epsilon$ , where  $\epsilon$  is the average layer spacing and  $N$  gives the film thickness in units of layers, the parameter  $a (= n_0 h k \cos(r))$  can be seen to be small for sufficiently thin films. For example, since  $n_0 \approx 1.5$ ,  $k = 9.93 \times 10^{-4}$

$\text{\AA}^{-1}$ ,  $\cos(r) \leq 1$ , and  $h \approx 50 \text{ \AA}$  for a two-layer film,  $a \approx 7.5 \times 10^{-2}$  and, therefore,  $\sin(a) \approx a$  in this case. Furthermore, since the system was constructed so that  $i \approx r \approx 0$ , Eq. (1) can be greatly simplified for sufficiently thin films ( $N < 15$ ) so that

$$R \approx (1 - n_0^2)^2 (N\epsilon k)^2 / 4. \quad (2)$$

Because of the quantized nature of the films and since  $R = \xi N^2$ , the film thickness (in units of smectic layers) can be determined by spreading films until the measured values for the reflectivity begin to repeat, allowing the constant  $\xi$  (and the thickness of subsequent films) to be obtained [10].

The semimicroscopic nature of such films excludes many standard measurements and the construction of a simple table-top experiment capable of resolving phase transitions, especially the nature of the phase transition, in these films is not an easy task. However, the impressive signal-to-noise ratio of the reflectivity measurement has allowed it to provide information unobtainable by any other means presently available and become a powerful tool in investigating the nature of phase transitions in effectively two-dimensional free-standing films.

Figure 3 displays the measured reflectivity near the Sm-*A*-Hex-*B* transition of a two molecular layer thick film of the liquid-crystal compound 3(10)OBC (a member of the *nm*OBC, *n*-alkyl-4'-*n*-alkoxybiphenyl-4-carboxylate, homologous series). Previously, we have reported heat capacity and optical reflectivity results from simultaneous measurements of two-layer 3(10)OBC films [11]. To obtain the heat capacity data, an ac heat source (a chopped ir laser) was used to induce  $a \pm 5 \text{ mK}$  temperature oscillation in the film. It is well known that the presence of such a temperature oscillation generally precludes the accurate detection of the latent heat associated with a first-order transition. Therefore, due to these limitations, we were only able to assert that the Sm-*A*-Hex-*B* transition observed in two-layer 3(10)OBC films was continuous to within our 10-mK experimental resolution. Because the reflectivity experiment alone requires no such

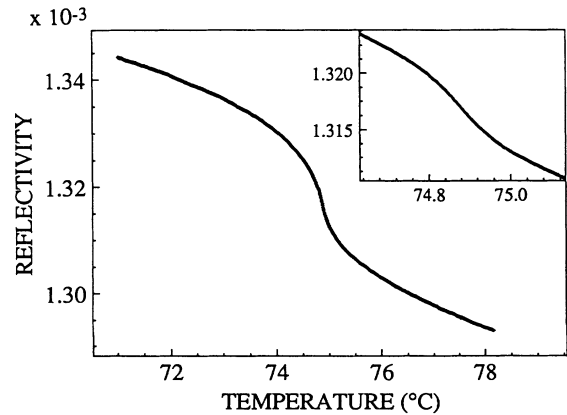

FIG. 3. Measured reflectivity near the Sm-*A*-Hex-*B* transition of a two-molecular layer thick 3(10)OBC film. The inset shows the details of the reflectivity in the immediate vicinity of the transition temperature.

temperature oscillation, it can be used to probe much closer to the transition temperature and substantially improve the temperature resolution. Moreover, because, as will be shown below, the reflectivity is related to a first derivative of the free energy (namely, the molecular density), it should be sensitive to the presence of a first order transition. The two-layer 3(10)OBC Sm-*A*-Hex-*B* phase transition is apparent in the reflectivity data presented in Fig. 3 by the sign change in the curvature near 74.9°C. The smooth variation in the slope of the curve provides strong evidence of the continuous nature of this transition. Furthermore, the inset allows the temperature dependence of the reflectivity to be examined in the immediate vicinity of the transition. From this data, we can conclude that this transition is continuous to within only 2 mK, a significant improvement.

Figure 4 exhibits reflectivity data near the Sm-*A*-Hex-*B* transition of the two interior layers and Hex-*B*-Cry-*E* transition of the two outer layers of a four-layer 75OBC film. The Sm-*A*-Hex-*B* transition again appears as a continuous variation in the slope near 64.5°C but the strongly first-order Hex-*B*-Cry-*E* transition appears as a very sharp jump in the reflectivity data. Because the Sm-*A*-Hex-*B* transition of the two outer layers was found to occur above 74°C and the film ruptured irreproducibly near the interior Hex-*B*-Cry-*E* transition (at about 58°C), these transitions could not be included in Fig. 4. The phase sequences have been identified through both electron-beam and x-ray diffraction experiments [12].

The reflectivity data is important because it can be related to the molecular density of the films. This can be understood simply as the increased packing efficiency of the more ordered phase increasing the index of refraction and, by Eq. (2), the measured reflectivity. This argument can be formalized using the Lorentz-Lorenz equation [13] relating the index of refraction,  $n_0$ , to the number density,  $\rho$ , through

$$\rho = \frac{3}{4\pi\gamma} \left[ \frac{n_0^2 - 1}{n_0^2 + 2} \right]. \quad (3)$$

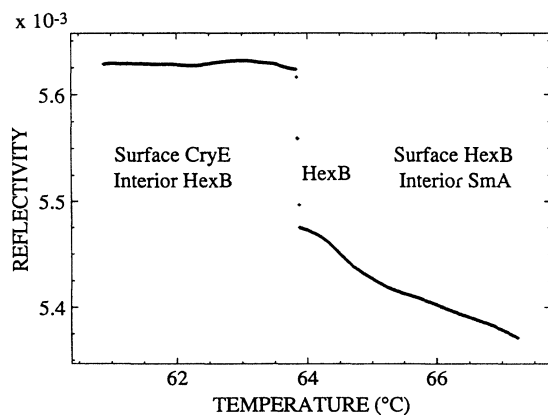

FIG. 4. Measured reflectivity near the interior Sm-*A*-Hex-*B* and surface Hex-*B*-Cry-*E* transitions of a four-molecular layer thick 75OBC film.

The molecular polarizability is given by  $\gamma$ . Taking  $c = 3/4\pi\gamma$ , this can be rewritten as

$$n_0 = \left[ \frac{c + 2\rho}{c - \rho} \right]^{1/2}. \quad (4)$$

Substituting this into Eq. (2), and solving for the molecular number density,  $\rho$ , gives

$$\rho(R) = \frac{c}{1 + \frac{3hk}{2\sqrt{R}}}. \quad (5)$$

The density can therefore be determined as a function of the measured reflectivity. It should be noted that, in principle, there are no adjustable parameters in this analysis. However, since no reliable values for the molecular polarizability could be obtained and because the Lorentz-Lorenz relation may not be expected to hold exactly for the (relatively dense, semimicroscopic) films, the constant,  $c$  ( $=6.0 \times 10^{-3} \text{ \AA}^{-3}$ ), was determined using nominal values for the index of refraction ( $n_0 = 1.5$ ) and the density ( $\rho = 1.766 \times 10^{-3} \text{ \AA}^{-3}$ ) and Eq. (4). Moreover, to determine the temperature dependence of the density, we have also assumed that both the molecular polarizability and film thickness do not change appreciably over the temperature windows of interest. Using the reflectivity data presented in Fig. 3, the temperature profile of the density near the Sm-*A*-Hex-*B* was calculated under these assumptions and is shown in Fig. 5. As expected, the increase in the sixfold coordination of the Hex-*B* phase allows the molecules to pack more efficiently and the density increases accordingly. Again, the continuous, smooth increase in density is highly suggestive of the continuous nature of this transition.

The molecular density of the films can also be determined through x-ray diffraction experiments. We have, therefore, calculated the temperature dependence from such an experiment near the Sm-*A*-Hex-*B* transition of a thick 46OBC free-standing film and included these data in Fig. 5 for comparison [14]. After shifting the temperature axis to account for the difference in transition tem-

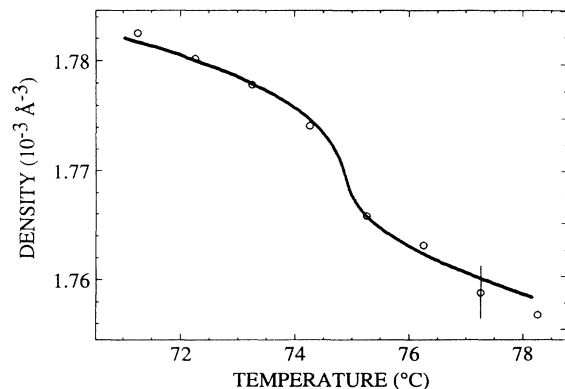

FIG. 5. Density calculated from the reflectivity data presented in Fig. 3 (line) and from the x-ray study by Davey *et al.* [14] (circles). The reflectivity method clearly yields data of significantly greater relative resolution.

peratures between the two compounds, it is clear that the agreement is excellent, strongly supporting the above assumptions and our novel measurement technique. It should also be noted that the temperature resolution and relative density resolution of our technique are also substantially greater than the powerful, but painstaking, x-ray experiments. In fact, because at least 15 min are required to obtain reasonable counting statistics on very thin films even under a synchrotron light source, our method provides temperature resolution far superior to any other presently available.

Applying the procedure described above, the reflectivity data exhibited in Fig. 4, has also been transformed to yield the temperature dependence of the molecular density near the Hex-*B*-Cry-*E* transition of a four-layer thick film of 75OBC. As evident in Fig. 6, the density increases sharply at the transition temperature, consistent with the first-order nature of this transition. The transition widths are exceptionally narrow, roughly  $6 \times 10^{-5}$  in reduced temperature ( $t = |T - T_c|/T_c$ ). The expected density change could again be calculated using lattice parameters obtained from x-ray experiments [15]. The observed variation in density is highly consistent with only two of the four layers undergoing the Hex-*B*-Cry-*E* transition. It is apparent that, due to the stabilizing effects of the surface tension inherent in the film-vapor interfaces, the two outermost layers order at a temperature substantially above the bulk Hex-*B*-Cry-*E* transition temperature. Such surface ordering has also been widely observed in a number of other free-standing liquid-crystal film systems [16].

The expected density jump has been included as an *I* beam in Fig. 6. Once again, the excellent agreement between our data and the data obtained from the x-ray diffraction study strongly supports our technique. Moreover, it is interesting to note that a small plateau (only 10 mK wide) can be observed roughly in the middle of the jump. This most likely separates the transition in the top and bottom surfaces and would be virtually impossible to detect in an x-ray experiment, again indicating the impressive temperature resolution of the reflectivity probe. A number of attempts were made to detect the Hex-*B*-Cry-*E* transition of the interior layers. Unfortunately, however, this proved impossible since the films consistently ruptured near the bulk Hex-*B*-Cry-*E* transition temperature (58°C), possibly due to a strain produced by the incommensurate nucleation of the interior Cry-*E* phase relative to the unaligned outer layers.

As mentioned above, the treatment of the Sm-*A* and Hex-*B* phases was simplified because of their uniaxiality on length scales comparable to the illuminated spot size. The Cry-*E* phase, however, is weakly birefringent [8]. Since the laser used for the optical reflectivity measurement is polarized, it is sensitive to the domain structure and local orientation of the Cry-*E* axes (not easily con-

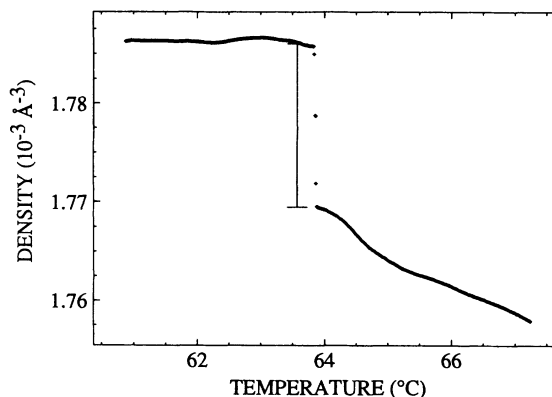

FIG. 6. Density calculated from the reflectivity data presented in Fig. 4. The Hex-*B*-Cry-*E* transition appears as a discontinuous jump in the density data. The *I* beam represents the jump expected based on densities determined from lattice parameters obtained through an x-ray diffraction experiment [15].

trolled in the free-standing films). The runs with the largest jumps (implying few domains) were found to be the most reproducible and consistent with the existing x-ray data.

#### IV. DISCUSSION

A system capable of measuring the optical reflectivity of very thin free-standing liquid crystal with high resolution ( $S/N = 5 \times 10^4$ ) has been established in our laboratory. Moreover, the resolution of this experiment has allowed both the Sm-*A*-Hex-*B* and Hex-*B*-Cry-*E* transitions in films of the *nm*OBC homologous series to be investigated. The experimental data has enabled us to conclude that the Sm-*A*-Hex-*B* transition in two-layer 3(10)OBC films is continuous to within 2 mK.

A simple calculation has been presented allowing the temperature dependence of the molecular density to be determined from the reflectivity data. The resultant density profiles have been shown to be in good agreement with density data calculated from lattice parameters obtained through x-ray diffraction experiments, strongly supporting the capabilities of this measurement technique. Applications of this unique experimental tool to explore the nature of other phase transitions in liquid-crystal films are in progress.

#### ACKNOWLEDGMENTS

This work was partially supported by the National Science Foundation, Solid State Chemistry Program, Grants No. DMR89019334, No. DMR9024992, and No. DMR9300781. One of us (T.S.) would like to acknowledge support from the Department of Education and IBM.

- [1] P. S. Pershan, *Structure of Liquid Crystal Phases* (World Scientific, Singapore, 1988); R. Pindak, D. E. Moncton, S. C. Davey, and J. W. Goodby, *Phys. Rev. Lett.* **46**, 1135 (1981); J. D. Brock, A. Aharony, R. J. Birgeneau, K. W. Evans-Lutterodt, J. D. Litster, P. M. Horn, G. B. Stephenson, and A. R. Tajbakhsh, *ibid.* **57**, 98 (1986), and references found therein.
- [2] M. Cheng, J. T. Ho, S. W. Hui, and R. Pindak, *Phys. Rev. Lett.* **59**, 1112 (1987).
- [3] S. B. Dierker, R. Pindak, and R. B. Meyer, *Phys. Rev. Lett.* **56**, 1819 (1986); S. Sprunt and J. D. Litster, *ibid.* **59**, 2682 (1987), and references found therein.
- [4] R. Pindak, D. J. Bishop, and W. O. Sprenger, *Phys. Rev. Lett.* **44**, 1461 (1980); J. C. Tarczon and K. Miyano, *ibid.* **46**, 119 (1981).
- [5] R. Geer, T. Stoebe, and C. C. Huang, *Phys. Rev. E* **48**, 408 (1993).
- [6] C. Y. Young, R. Pindak, N. A. Clark, and R. B. Meyer, *Phys. Rev. Lett.* **40**, 773 (1978).
- [7] R. Geer, T. Stoebe, T. Pitchford, and C. C. Huang, *Rev. Sci. Instrum.* **62**, 415 (1991).
- [8] G. W. Gray and J. W. Goodby, *Smectic Liquid Crystals: Textures and Structures* (Leonard Hill, Glasgow, 1984).
- [9] M. Born and E. Wolf, *Principles of Optics* (Pergamon, Oxford, 1975).
- [10] C. Rosenblatt and N. Amer, *Appl. Phys. Lett.* **36**, 432 (1980).
- [11] T. Stoebe, C. C. Huang, and J. W. Goodby, *Phys. Rev. Lett.* **68**, 2944 (1992).
- [12] R. Geer, T. Stoebe, C. C. Huang, R. Pindak, G. Srajer, J. W. Goodby, M. Cheng, J. T. Ho, and S. W. Hui, *Phys. Rev. Lett.* **66**, 1322 (1991).
- [13] J. D. Jackson, *Classical Electrodynamics* (Wiley, New York, 1975).
- [14] S. C. Davey, J. Budai, J. W. Goodby, R. Pindak, and D.E. Moncton, *Phys. Rev. Lett.* **53**, 2129 (1984).
- [15] C. C. Huang and R. Pindak (unpublished).
- [16] R. Pindak, D. J. Bishop, and W. O. Sprenger, *Phys. Rev. Lett.* **44**, 1461 (1980); S. Heinekamp, R. A. Pelcovits, E. Fontes, E. Y. Chen, R. Pindak, and R. B. Meyer, *ibid.* **52**, 1017 (1984); B. M. Ocko, A. Braslau, P. S. Pershan, J. Als-Nielsen, and M. Deutsch, *ibid.* **57**, 94 (1986); B. D. Swanson, H. Stragier, D. J. Tweet, and L. B. Sorensen, *ibid.* **62**, 909 (1989); W. Chen, L. J. Martinez-Miranda, H. Hsiung, and Y. R. Shen, *ibid.* **62**, 1860 (1989), and references found therein.