

Surfacelike-elasticity-induced spontaneous twist deformations and long-wavelength stripe domains in a hybrid nematic layer

V. M. Pergamenschchik

*Faculty of Mathematical Studies, University of Southampton, Southampton SO9 5NH, United Kingdom
and Institute of Physics, Ukrainian Academy of Sciences, prospekt Nauki 46, Kiev-28, Ukraine**

(Received 19 June 1992; revised manuscript received 23 November 1992)

We consider the effect of the divergence K_{24} term $\nabla[\mathbf{n}(\nabla\mathbf{n})+\mathbf{n}\times\nabla\times\mathbf{n}]$ in the nematic free energy, which has been ignored for a long time. The K_{24} term is shown to be able to cause spontaneous twist deformations. This mechanism is irrespective of the bulk Frank constant anisotropy in contrast to the well-known mechanism associated with the smallness of the twist elastic constant K_{22} . For geometries with sufficiently large surface-to-volume ratios, it can also be effective in other condensed media described by similar free-energy functionals, but with considerably less anisotropic constants than liquid crystals (e.g., the B phase of liquid ^3He and ferromagnets). As a specific model we consider the formation of long-wavelength stripe domains in a usual but rather thin hybrid nematic layer. Degenerate boundary conditions are imposed on the surfaces of the latter. Recent experiments show the existence of such domains in a hybrid nematic layer whose state had always been regarded as homogeneous in the layer plane. The theory worked out in the paper allows one to incorporate all the harmonics of the periodic domain structure in the vicinity of the critical point. The dependence of the domain period on the layer thickness, obtained in the paper, makes it possible to find the value of the elastic constant K_{24} from the experimental data.

PACS number(s): 05.70.Fh, 61.30.Gd, 64.70.Md

I. INTRODUCTION

The continuum approach to the study of the systems of rodlike molecules—liquid crystals and nematics in particular—has been successively applied for decades to describe the macroscopic structures in such condensed media. Paradoxical is the fact that one of the terms quadratic with respect to the director derivatives, namely, the K_{24} term, which is contained in the nematic free energy (FE) on equal grounds with the usual Frank terms (splay plus twist plus bend), is somehow mysterious; since the effects associated with the presence of the K_{24} term in the FE have been unknown, retaining this term has been regarded as doubtful or not necessary. Indeed, though this term was derived in the papers of Oseen [1] and Frank [2] and, 40 years later, by Nehring and Saupe [3], it has not attracted researchers' attention until recently [4–12].

The part of the nematic FE, quadratic with respect to the director derivatives, is given by

$$F = \frac{1}{2} \int dV \{ K_{11}(\nabla\mathbf{n})^2 + K_{22}(\mathbf{n}\cdot\nabla\times\mathbf{n})^2 + K_{33}(\mathbf{n}\times\nabla\times\mathbf{n})^2 - 2(K_{22} + K_{24})\nabla[\mathbf{n}(\nabla\mathbf{n}) + \mathbf{n}\times\nabla\times\mathbf{n}] \}. \quad (1)$$

The last addend in the FE density is just the K_{24} term. It is of divergence form, which has been the main reason for ignoring it, since it does not change the form of the Euler-Lagrange equations corresponding to the functional (1). Of course, such reasoning is not justified, because the divergence form of the K_{24} term does not imply its smallness.

Another reason for which taking the K_{24} term into account did not seem to be obvious is that it is nonzero only under the condition that the director must depend on two or more Cartesian coordinates. Thus the director geometry must be rather complicated and, moreover, the ratio of the nematic surface S to its volume V must be sufficiently large for the volume contribution $\int dV f_F$ to be of an order of magnitude comparable with the surface integral $\int dS[\mathbf{n}(\nabla\mathbf{n}) + \mathbf{n}\times\nabla\times\mathbf{n}]$, which is the K_{24} -term contribution reduced by means of the Gauss theorem.

The third reason for disregarding the K_{24} -term contribution is that in the geometries considered, this term has not led to any new qualitative effects, and neglecting it in the worst case could introduce some quantitative discrepancies, which always could be attributed to the inaccuracy in calculating other parameters of the problem.

So, the physical consequences of retaining the K_{24} term in the FE seemed to be doubtful. Furthermore, this term caused some mathematical difficulties. In the standard variational problem, the extrema of which are the solutions of the Euler-Lagrange equations, the surface part of the functional does not contain the director derivatives. However, they enter the surface density of the K_{24} term. This was the reason for regarding the variational problem with the K_{24} term as ill-posed [4,6], while treating as well-posed the partial cases with the K_{24} -term surface density depending only on \mathbf{n} but not on $\partial\mathbf{n}$. This reason alone led the author of Ref. [4] to choose a special model in which the director derivatives appearing in the surface part of the FE vanish (the relevant conditions are derived in Ref. [7]), in an attempt to construct theoretically a sys-

tem which in principle would be sensible to the variation of the constant K_{24} . Recently, however, the problem of minimizing the FE with the K_{24} term was shown to be always well posed, the family of extremes was found to be the solutions of the Euler-Lagrange equation for F (1), and the K_{24} term was shown to change the standard boundary condition on the nematic surface [7,8].

Thus the problem of the K_{24} term in the nematic free energy requires revealing the relevant physical consequences, which is clearly understood now [10]. The best way to show that taking the K_{24} term into account is important is to discover an effect whose very occurrence is determined by the elastic constant K_{24} . One such effect turns out to exist and even to be experimentally observable. Reference [9] reported the experimental discovery of the domain structure in a thin hybrid nematic layer that was assumed to be associated with the K_{24} term in the nematic FE. In particular, the critical condition [9] for the long-wavelength periodic domain formation depends on the elastic constant K_{24} and does not depend on the elastic constant K_{22} and therefore the effect by its essence is different from the stripe Fréedericksz effect [13] which can occur only for sufficiently small K_{22} . It is important to emphasize that the hybrid nematic layer (HNL) surfaces were isotropic in the sense that no distinguished direction was fixed on them and the director could rotate without energy losses [9]. In other words, the azimuthal anchoring was zero in the experiments [9] and the boundary conditions were azimuthally degenerate. This boundary isotropy allows other interesting nonhomogeneous structures to occur in a comparatively thicker HNL [14,15].

For further discussion it is convenient to describe certain known features of nonperturbed HNL states (without domains) and to introduce some notations. It is known [17] that in a HNL, whose one surface orients long molecular axes parallel to the layer whereas another one imposes normal orientation, the director depends on a single coordinate z along the normal to the layer. However, when the layer thickness h is sufficiently small, the z dependence disappears and the director is undistorted. Here we are interested in the case when the anchoring on the planar-orienting surface is stronger than on the normal-orienting one. In this case it means that for $h > h_a$, where h_a is a well-known critical value [17], the tilt angles θ_1 and θ_2 of the director on the two surfaces are different, while they are both equal to $\pi/2$ for $h \leq h_a$. In the latter case, the director is planar and, hence, coordinate independent; $\theta(z) = \text{const} = \pi/2$.

The stripe domains (SD's) are observed to exist in HNL's whose thickness h is smaller than some critical value h_c and larger than some other critical value h_d . Outside the interval $h_d < h < h_c$, i.e., for $h < h_d$ and $h > h_c$, SD's do not appear in HNL's. In principle, h_a can belong or not belong to the interval (h_d, h_c) . The stripe domain structure in the HNL has already attracted attention. Reference [16] deals with the influence of the HNL surface azimuthal anisotropy on the domain formation in the simplest case when the layer thickness h is smaller than h_a . The authors of [16] considered only the

behavior of the critical thickness h_d , above which periodic domains appear in the HNL, and did not manage to find the upper limit h_c since it is likely that $h_c > h_a$. For $h \lesssim h_a$ the elastic constant K_{22} is shown to play an important role [16].

The theoretical analysis of HNL's with $h > h_a$ is far more complicated than for $h \leq h_a$ because for $h > h_a$ the director of the nonperturbed state becomes coordinate dependent [17] and the coefficients of the relevant equations are no longer constant. This case was considered in Ref. [9]. However, only the condition was found which determines the upper limit h_c for which stripe domains appear in the HNL. Actually, the effect of SD formation in the HNL requires a detailed theoretical analysis; in particular, it should give the SD period L as a function of the layer thickness h . Inasmuch as, according to Ref. [9], the constant K_{24} can be important for this effect, the $L(h)$ dependence would enable one to compare theoretical and experimental data and to find the value of K_{24} . We have already mentioned that the value of the constant K_{22} may be crucial for the HNL state for $h < h_a$ [16]. Hence, the effect should be analyzed for values of h for which the K_{24} term is dominant and the K_{22} is less important. Such are the thicknesses $h > h_a$ and the problem becomes much more complicated.

The effect of the K_{24} term is of interest not only in liquid crystals. Though a similar term can be introduced in the ferromagnetic free energy [18], it has been ignored for the same reasons as given above. Another example is the liquid helium ^3He free energy. As far as we know, the K_{24} term has been introduced explicitly [19]; however, the relevant effects have not been discussed. Hence, revealing the mechanism of the K_{24} -term action and obtaining relevant effects may be of importance for other condensed media in which such terms are allowed by symmetry. In what follows we show that the stripe domains which were discovered experimentally in a standard sufficiently thin hybrid cell [9] exist solely due to the presence of the K_{24} term in the nematic FE. In our paper, the hypothesis of Ref. [9] is confirmed by the detailed study of the long-wavelength SD formation mechanism in a HNL whose state has always been regarded as homogeneous over the layer plane (see, e.g., Refs. [17,20]). We show that when the nematic is in the domain state, there appear simultaneously two perpendicular twist deformations, so that the K_{24} term can give rise to spontaneous violation of the chiral symmetry of the director distribution in the nematic. As distinct from the blue phase, whose disclination model essentially employs the mechanism of the additional twist formation in the cholesteric due to the K_{24} -term [21], these deformations do not give rise to any singularities of disclination type in the nematic. We show that the K_{24} mechanics of spontaneous twist formation from the chirally symmetric state of the nematic is effective in a range of parameters other than that of the known mechanism associated with the smallness of the elastic constant K_{22} as compared to K_{11} or K_{33} . In particular, the K_{24} mechanism can act for $K_{22} > K_{11}, K_{33}$ since its effect weakly depends on the elastic constant K_{22} . In a hybrid cell, the K_{24} mechanism

leads to the formation of a stripe domain structure with a period much greater than the layer thickness, while the K_{22} mechanism is effective only for periods comparable to the thickness. The theory worked out allows one to take into account all harmonics of the periodic structure, which are shown to be excited simultaneously at the instant of the transition into the domain state. The formulas for the domain period obtained in the paper make it possible to find the value of the elastic constant K_{24} from the experimental dependence of the period on the HNL thickness.

II. PHASE TRANSITION BETWEEN THE HOMOGENEOUS AND DOMAIN STATES IN A HNL

The HNL is one of the simplest traditional subjects under consideration in physics of liquid crystals. Its state has been regarded as homogeneous in the layer plane. However, this assumption is sometimes invalid [9,16]. Let us consider when the homogeneous state (HS) becomes unstable and what is its transformation.

Let us consider a HNL of thickness h (Fig. 1) between the lower $z=0$ and upper $z=h$ planes, which are normal to the z axis. The boundary conditions on the surfaces S_s are degenerated (the director rotates on the layer surface without energy losses) and different for upper ($s=2$) and lower ($s=1$) surfaces. In the HS, deformations of the director \mathbf{n} , $\mathbf{n}=(\sin\theta\cos\Phi, \sin\theta\sin\Phi, \cos\theta)$, lie only in a vertical plane parallel to the (x,z) plane; $n_y=0$ (the y axis is normal to this plane). In the approximation $K_{11}=K_{33}=K$, which will be employed henceforth in order to simplify the formulas, the equilibrium HS of the director is described by the angles θ and Φ [17], i.e.,

$$\Phi=0; \quad \theta=(\theta_2-\theta_1)\frac{z}{h}+\theta_1, \quad (2)$$

where Φ is the angle between the x axis and the projection of \mathbf{n} onto the plane (x,y) , θ is the angle between \mathbf{n} and the z axis, and the boundary values θ_1 and θ_2 can be found by a standard procedure from the boundary condi-

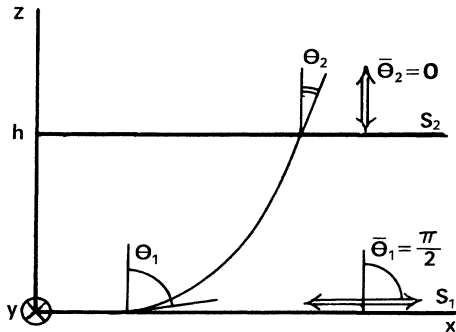

FIG. 1. The state of the hybrid nematic layer which is homogeneous (HS) in the layer plane $[(x,y)$ plane]. The director lies in the (x,z) plane. The arrows indicate easy directions on the lower (S_1) and the upper (S_2) surfaces of the layer. The y axis is perpendicular to the figure plane. No y component of the director appears in the HS.

tions

$$\begin{aligned} 2(\theta_2-\theta_1)+\frac{W_2h}{K}\sin 2(\theta_2-\bar{\theta}_2) &=0, \\ 2(\theta_1-\theta_2)+\frac{W_1h}{K}\sin 2(\theta_1-\bar{\theta}_1) &=0. \end{aligned} \quad (3)$$

Here W_s are the constants appearing in the anchoring energy of the Rapini-Papular type with the surface S_s , and $\bar{\theta}_s$ is the angle between the external normal \mathbf{v}_s to S_s and the easy direction on S_s . In our special case the easy orientation axis fixes the planar orientation $\bar{\theta}_1=\pi/2$ on the lower surface S_1 , and the homeotropic orientation $\bar{\theta}_2=0$ on the upper one S_2 .

In the approximation $K_{11}=K_{33}=K$, the nematic FE is given by

$$\begin{aligned} F &= \frac{K}{2} \int dv [(\nabla\mathbf{n})^2 + (\nabla\times\mathbf{n})^2 - (1-t)(\mathbf{n}\cdot\nabla\times\mathbf{n})^2] \\ &+ \frac{1}{2} \sum_{s=1,2} \int dS_s \{ -Kp\mathbf{v}_s[\mathbf{n}(\nabla\mathbf{n}) + \mathbf{n}\times\nabla\times\mathbf{n}]_{z,s} \\ &+ W_s \sin^2(\theta_s - \bar{\theta}_s) \}, \end{aligned} \quad (4)$$

where $t=K_{22}/K$, $p=2(K_{22}+K_{24})/K$, and the K_{24} term proportional to p is already reduced to the surface integral; $\mathbf{v}_s=(\mathbf{v}_s)_z$, i.e., $\mathbf{v}_1=-1$, $\mathbf{v}_2=1$.

The direct approach to the minimization of the functional (4) is to solve the Euler-Lagrange equations [7,8]. In the case of our interest, these are nonlinear partial differential equations with no hope of being solved. So we consider the loss of HS stability and the transition into the SD state by means of a Landau-type theory, with the FE (4) being expanded in Taylor functional series in the vicinity of the HS.

Suppose both the domain state $\mathbf{n}'=\mathbf{n}+\delta\mathbf{n}$ and the HS \mathbf{n} are extrema of the functional (4), $(\delta F/\delta\mathbf{n})\{\mathbf{n}'\}=(\delta F/\delta\mathbf{n})\{\mathbf{n}\}=0$, where $|\delta\mathbf{n}|\ll 1$. Then, with accuracy up to the fourth variation, we have

$$\Delta F = F\{\mathbf{n}'\} - F\{\mathbf{n}\} = \frac{1}{2}\delta^2 F + \frac{1}{3!}\delta^3 F + \frac{1}{4!}\delta^4 F + \dots \quad (5)$$

If there exists such $\delta\mathbf{n}$ for which $\Delta F < 0$, then a phase transition into the state \mathbf{n}' occurs. The critical point is determined by the condition $\min_{\delta\mathbf{n}} \delta^2 F\{\mathbf{n}, \delta\mathbf{n}\} = 0$.

Let us consider the phase transition from the HS \mathbf{n} into the domain state $\mathbf{n}'=\mathbf{n}+\delta\mathbf{n}$ periodic along the y axis with period L . Suppose $\partial/\partial x=0$, $A_{x_i} \equiv \partial A/\partial x_i$, $\tau=1-t$, $\delta\theta=\psi$, and $\delta\Phi=\phi$. The angles $\psi=\delta\vartheta(x,y,z)=\vartheta'-\vartheta$ and $\phi(x,y,z)=\Phi-0$ have a simple meaning. In order to transform the unperturbed director $\mathbf{n}(\mathbf{r})$ into the perturbed $\mathbf{n}'(\mathbf{r})$ at an arbitrary point $\mathbf{r}=(x,y,z)$, the former has to be rotated first through the angle $\delta\vartheta$ around the y' axis parallel to the y axis, and then through the angle ϕ around the z' axis parallel to the z axis, both y' and z' axes intersecting at the point (x,y,z) . Thus the angles ψ and ϕ can be associated, respectively, with the perturbations in the x,y plane and with the perturbations normal to it.

Employing the suitable identity

$$(\nabla \mathbf{n})^2 + (\nabla \times \mathbf{n})^2 \equiv \sum_{i,j=1}^3 (\partial_i n_j)(\partial_i n_j) + \nabla[\mathbf{n}(\nabla \mathbf{n}) + \mathbf{n} \times \nabla \times \mathbf{n}], \quad (6)$$

we separate from the bulk FE (1) the divergence term analogous to the K_{24} term. The second variation (per unit surface of the HNL), $\delta^2 F$, is the part of ΔF that is quadratic with respect of ψ and ϕ . Performing rather routine calculations, we have

$$\delta^2 F = \frac{K}{2L} \int_0^h dz \int_0^L dy [\psi_z^2 + t\psi_y^2 + \sin^2\theta\phi_z^2 + \sin^2\theta(1-\tau\sin^2\theta)\phi_z^2 - 2\tau\sin^2\theta\phi_z\psi_y] + \frac{K}{2L} \sum_{s=1,2} \int_0^L dy [2(1-\rho)v_s(\sin^2\theta\psi_y\phi) + c_s\psi^2](z=z_s), \quad (7)$$

where $c_s = (W_s/K)\cos 2(\theta_s - \bar{\theta}_s)$.

Since the SD's are periodic along y , they can be represented in the Fourier series form. The zeroth harmonic $\phi_0 = \phi_0(z)$ is not excited because its contribution in (7) is non-negative. As for ψ , its constant component can be excited for $c_s < 0$. This corresponds to the well-known HNL transition from the state with $\theta_1 = \theta_2 = \pi/2$ into the one with $\theta_1 > \theta_2$ which occurs for $h = h_a$, as we have already mentioned in the Introduction [17]. However, all perturbations of the form $\psi(z)$ (including the above-mentioned transition) are already taken into account in the dependence $\theta_s(z)$ determined by Eqs. (3), and hence the zeroth harmonic of ψ must be omitted in (7). Then we have

$$\psi(y, z) = \sum_{n=1}^{\infty} [f_n(z)\sin(qny) + z_n(z)\cos(qny)], \quad (8)$$

$$\phi(y, z) = \sum_{n=1}^{\infty} [g_n(z)\cos(qny) + p_n(z)\sin(qny)].$$

It is shown in Appendix A that the symmetry of the functional (7) allows both r_n and p_n to be set equal to zero by means of appropriate choice of the reference origin on the y axis. Thus we deal with an even function ϕ and an odd function ψ with respect to the variable y .

Expressing $\delta^2 F$ in terms of the harmonics f_n and g_n , introducing the dimensionless wave number $\chi = qh$ and coordinate $\bar{z} = z/h$ (we shall henceforth omit the overbar), denoting derivatives with respect to z by primes, and integrating over the period of the variable y result in

$$\frac{1}{2}\delta^2 F = \frac{K}{4h} \sum_{n=1}^{\infty} \left\{ \int_0^1 dz [f_n'^2 + t(n\chi)^2 f_n^2 + (n\chi)^2 \sin^2\theta g_n^2 + \sin^2\theta(1-\tau\sin^2\theta)g_n'^2 - 2(n\chi)\tau\sin^2\theta g_n' f_n] + \sum_{s=1,2} [2v_s(\chi n)(1-p)\sin^2\theta f_n g_n + hc_s f_n^2](z=z_s) \right\}. \quad (9)$$

As a functional of $\{f_n, g_n\}$, $\delta^2 F$ (9) is minimum for f_n and g_n which satisfy the Euler-Lagrange equations

$$f_n'' - t(n\chi)^2 f_n + (n\chi)\tau\sin^2\theta g_n' = 0, \quad (10)$$

$$\frac{d}{dz} [\sin^2\theta(1-\tau\sin^2\theta)g_n' - (\chi n)\tau\sin^2\theta f_n] - (\chi n)^2 \sin^2\theta g_n = 0. \quad (11)$$

Expression (9) contains two positive indefinite terms due to which $\delta^2 F$ can vanish. The first bulk terms of density $f_{22} = -2(n\chi)\tau\sin^2\theta g_n' f_n$ is proportional to $\tau = 1 - t$; therefore, the smaller t , the greater the absolute value of this term. The second is a surface term of density

$$f_{24} = 2(n\chi)(1-p)[\sin^2\theta_2 f_n(1)g_n(1) - \sin^2\theta_1 f_n(0)g_n(0)].$$

It is proportional to $1-p = 1 - (K_{22} + K_{24})/K$ and its contribution grows with increasing $|1-p|$. Since $t = K_{22}/K$ while f_{24} depends on K_{24} , it is natural to refer to the stability loss mechanism, associated with the negativity of the first term, as the K_{22} mechanism, and to call

the second mechanism the K_{24} mechanism. Both these are associated with the spontaneous violation of the nematic HS chiral symmetry: both f_{22} and f_{24} vanish for the HS, and their spontaneous finiteness after the transition implies the existence of twist deformations. Let us consider each of the mechanisms individually.

A. K_{22} mechanism

This mechanism of spontaneous twist deformation in nematic is well known. Usually, the value of K_{22} is smaller than K_{11} and K_{33} and, if splay and bend deformations are sufficiently strong, twist formation accompanied by the decrease of these is energetically profitable. Just this K_{22} mechanism is responsible for the formation of stripe domains under sufficiently small K_{22} in the Freedericksz transition [13]. The situation is different in our case with no interaction between the nematic and the magnetic field.

One cannot manage to solve the Euler-Lagrange equations (10) and (11) for arbitrary not small χ [we remind

the reader that (10) and (11) are the equations with variable coefficients, since $\theta = \theta(z)$. But we shall show that the K_{22} mechanism is effective just in this range $\chi \approx 1$, which will be referred to as the short-wavelength range. Let us roughly estimate the critical layer thickness h_{22} — the short-wavelength SD's appear in the HNL thinner than h_{22} . The sufficient condition for SD formation is nonpositiveness of the FE density for $h < h_{22}$. As follows from (9) for $\chi \approx 1$, the terms f_{22} and f_{24} are of the same order of magnitude. For $h < h_{22}$, the absolute value of their sum must be greater than the sum of all other terms entering the density $\delta^2 F$. This requirement can be written as

$$\frac{\langle f' \rangle^2 + t(n\chi)^2 \langle g \rangle^2 + h_{22}(c_1 f_1^2 + c_2 f_2^2)}{\sin^2 \langle \theta \rangle} + (n\chi)^2 \langle g \rangle^2 + (1-\tau) \langle g \rangle^2 \geq |2(n\chi) \langle g \rangle \langle f \rangle + (1-p) \langle g \rangle \langle f \rangle|, \quad (12)$$

where $\langle \theta \rangle$, $\langle f \rangle$, $\langle f' \rangle$, and $\langle g \rangle$ are corresponding values averaged over the z coordinate. Evidently, taking here $\sin^2 \langle \theta \rangle = 1$ weakens the transition condition and sets h_{22} too high. Such a weakened condition can be reduced to the form

$$\frac{(\chi n)(\tau + 1 - p)}{t + (n\chi)^2} - t(\chi n)^2 \geq [\langle f' \rangle^2 + h_{22}(c_1 f_1^2 + c_2 f_2^2)] \langle f \rangle^{-2}. \quad (13)$$

The restriction on $K_{22} + K_{24}$, derived in [22], yields $\max(1-p) = 1$. Therefore taking $1-p = 1$ again weakens the transition condition. Typical values of t for nematics lie within the range 0.5–0.3. Substituting $1-p = 1$ in (13), we observe the left-hand side of (13) to vary from 0 to 0.9 for these values of t . On the other hand, the vanishing of the right-hand side of (13) corresponds to the transition to the state $\theta(z) = \pi/2$ for $h = h_a$. Analysis shows (Appendix B) that the right-hand side behaves as $(h - h_a)^2$ for $h \approx h_a$, and as $1 + h_{22}/h_a$ for $h > h_a$. Therefore the inequality (13) can be represented in the form $\text{lhs}(t) \geq h_{22}/h_a$ for $h > h_a$, and in the form $1 + \text{lhs}(t) \geq \text{const}(h - h_a)^2$ for $h \approx h_a$, where the lhs as a function of t varies in the range 0–0.9 when t varies from 0.5 to 0.3. It follows from both these inequalities that $h_{22} \lesssim h_a$, so the short-wavelength SD can occur only in the planar state of a HNL which takes place for $h \leq h_a$. h_{22} is even lower for higher harmonics. Thus the joint action of the K_{22} and K_{24} mechanisms in the short-wavelength perturbation range considerably depends on the value of t : the SD's do not occur at all for $t > 0.5$ since $h_{22} < 0$. However, in contrast to the short-wavelength instability of the HNL, the K_{24} mechanism itself can cause the long-wavelength HNL instability with $\chi \ll 1$, the critical condition being t independent, so that this is the pure effect of the K_{24} mechanism. Inasmuch as the critical thickness h_{24} , below which the SD's are formed in the HNL, is appreciably greater than h_{22} , the action of the K_{24} mechanism can be observed in the HNL. In what follows we give a detailed analysis of this mechanism. We will see that, in fact, h_{24} is the upper

thickness for which SD's exist in the HNL. That is why in what follows we use for h_{24} the notation h_c introduced in the preceding section.

B. K_{24} mechanism

Let us consider the transition into the SD state with small $\chi \ll 1$, when the term f_{24} is dominant in the expression (9) for $\delta^2 F$. The presence of the small parameter enables one to represent the solutions of the Euler-Lagrange equations (10) and (11) as expansions in its power series. However, the search for such solutions may be simplified by estimating the leading orders of the variables f , f' , h , and g' from the condition necessary for the transition to occur.

Inequalities (14) and (15), which will be given below, have the meaning of relations between orders of magnitudes of different quantities, the order itself being determined only by the lowest power of χ and irrespective of the coefficient before it.

For f_{24} to be the leading term in $\delta^2 F$ (another possibility is considered below), its order of magnitude must not be lower than that of the first, third, and last terms in (9), i.e.,

$$(\chi n) f_n g_n \gtrsim f_n'^2, \quad (n\chi) f_n g_n \gtrsim f_n^2,$$

$$(\chi n) g_n f_n \gtrsim (n\chi)^2 g_n^2,$$

and hence the estimate is given by

$$f_n \sim g_n (n\chi) \gtrsim f_n'. \quad (14)$$

Moreover, for $\delta^2 F$ to attain its minimum, the fifth term, i.e., the f_{22} term in $\delta^2 F$, must not be smaller than the fourth one, $g_n'^2 \lesssim (n\chi) g_n' f_n$, which yields, together with (14), one more estimate for the order of magnitude, i.e.,

$$g_n' \lesssim (n\chi) f_n \sim (n\chi)^2 g_n. \quad (15)$$

The order-of-magnitude relations (14) and (15) show [23] that the first, third, and two last terms in $\delta^2 F$ are leading terms, $\sim g_n^2 (\chi n)^2$; the remaining terms, including the f_{22} term, are of the higher order, $\sim g_n^2 (\chi n)^4$.

Beginning from some powers of χ , the fourth variation $\delta^4 F$ of the expansion (5) (all odd variations are obviously identically zero) also contributes to the Euler-Lagrange equations. Thus Eqs. (10) and (11), obtained by varying $\delta^2 F$ only, must be solved with accuracy up to these powers. The leading terms of the fourth variation are given below [see formula (35)]. As follows from the form of $\delta^4 F$, the lowest corrections in Eqs. (10) and (11) are of fifth order with respect to χ [the first term of (35) would contribute to the order χ^4 of Eq. (10) if it was not surface-like]. Thus Eqs. (10) and (11) must be solved with accuracy up to the terms $O(\chi^5)$.

Let f_n and g_n be expressed by the series

$$f_n = \sum_{k=1}^{\infty} f_{n,k} (n\chi)^k, \quad g_n = \sum_{k=1}^{\infty} g_{n,k} (n\chi)^k,$$

where $f_{n,k}$ and $g_{n,k}$ are functions of z , k is an integer. It follows from (15) that $g_{n,1} = \text{const}$, $g_{n,2} = \text{const}$, and z dependence of g_n appears for the first time in $g_{n,3}$; in

terms of the third and fourth order in χ , both the derivative g'_n and the function g_n itself can be expressed in terms of $g_{n,1}, f_{n,2}$ and $g_{n,2}, f_{n,3}$, respectively, by means of (11):

$$g'_{n,k}(z) = \frac{1}{\sin^2\theta(1-\tau\sin^2\theta)} \times \left[\gamma_{n,k-2} \int_0^z \sin^2\theta dz + f_{n,k-1} + \gamma'_{n,k} \right], \tag{16}$$

$$g_{n,k}(z) = \tilde{g}_{n,k}(z) + \gamma_{n,k},$$

$$\tilde{g}_{n,k}(z) = \int_0^z g'_{n,k}(z) dz,$$

where $\gamma_{n,k}$ and $\gamma'_{n,k}$ are integration constants. As for f_n , we have $f_{n,1}=0$ according to (14) and, in the orders χ^2 , χ^3 , and χ^4 , Eq. (10) is equivalent to the equations

$$f''_{n,k} = 0, \quad k=2,3,$$

$$f''_{n,4} = t f_{n,2} - \tau(\sin^2\theta) g'_{n,3},$$

whose solutions are given by

$$f_{n,k} = \xi_{n,k} - \zeta_{n,k} z, \quad k=2,3,$$

$$f_{n,4} = \xi_{n,4} - \zeta_{n,4} z + \tilde{f}_{n,4}, \tag{17}$$

$$\tilde{f}_{n,4} = t \left[\xi_{n,2} \frac{z^2}{2} - \zeta_{n,2} \frac{z^3}{6} \right] - \tau \int_0^z dz \int_0^z dz' g'_{n,3}(z'),$$

where $\xi_{n,k}$ and $\zeta_{n,k}$ are integration constants. The system of equations (16) and (17) can be solved explicitly. The variables, entering this system, are found in the following order: $f_{n,2}, f_{n,3}$ (known functions) $\rightarrow g_{n,3}, g_{n,4} \rightarrow f_{n,4}$. Therefore formulas (16) and (17) give the general solutions of the Euler-Lagrange equations (10) and (11), i.e.,

$$g_n = (n\chi)g_{n,1} + (\chi n)^2 g_{n,2} + (\chi n)^3 [\tilde{g}_{n,3}(z) + \gamma_{n,3}] + (\chi n)^4 [\tilde{g}_{n,4}(z) + \gamma_{n,4}], \tag{18}$$

$$f_n = (\chi n)^2 (\xi_{n,2} - \zeta_{n,2} z) + (\chi n)^3 (\xi_{n,3} - \zeta_{n,3} z) + (\chi n)^4 (\tilde{f}_{n,4} + \xi_{n,4} - \zeta_{n,4} z),$$

which depend on known functions of integration constants appearing in (16) and (17). The form of expansion (18) suggests that it is convenient to change from variables $g_{n,1}, g_{n,2}, \gamma_{n,k}, \xi_{n,k}, \zeta_{n,k}, g_{n,k}$ to the renormalized ones $\gamma_n, \xi_n, \zeta_n, \tilde{g}_{n,3}$ defined by the relations

$$(\chi n)\gamma_n = (\chi n)[g_{n,1} + (\chi n)g_{n,2} + (\chi n)^2 \gamma_{n,3} + (\chi n)^3 \gamma_{n,4}],$$

$$(\chi n)^2 \xi_n = (\chi n)^2 [\xi_{n,2} + (\chi n)\xi_{n,3} + (\chi n)^2 \xi_{n,4}], \tag{19}$$

$$(\chi n)^2 \zeta_n = (\chi n)^2 [\zeta_{n,2} + (\chi n)\zeta_{n,3} + (\chi n)^2 \zeta_{n,4}],$$

$$(\chi n)^3 \tilde{g}_{n,3}(z) = (\chi n)^3 [\tilde{g}_{n,3} + (\chi n)\tilde{g}_{n,4}].$$

Expansion (18), when written in terms of these variables, takes the form

$$g_n = (\chi n)\gamma_n + (\chi n)^3 \tilde{g}_{n,3}(z), \tag{20}$$

$$f_n = (\chi n)^2 (\xi_n - \zeta_n z) + (\chi n)^4 \tilde{f}_{n,4}. \tag{21}$$

Formulas (20) and (21) are sufficient for writing the first three terms of the expansion (5) in a power series of χ : $\Delta F \propto \tilde{\Delta}_4 \chi^4 + \Delta_5 \chi^5 + \Delta_6 \chi^6$. First of all we consider the leading part $\tilde{\Delta}_4 \chi^4$ of ΔF , which contains only leading terms. The contribution of the n th harmonic $\tilde{\Delta}_{4,n}$ to $\tilde{\Delta}_4 = \sum_n \tilde{\Delta}_{4,n}$ may be obtained by substituting the first terms on the right-hand sides of (20) and (21) into the sum of these terms. $\tilde{\Delta}_{4,m}$ is then given by the quadratic form in γ_n, ξ_n , and ζ_n , i.e.,

$$\tilde{\Delta}_{4,n} = \zeta_n^2 + a\gamma_n^2 - 2(1-p)\gamma_n [\xi_n \sin^2\theta_1 - (\xi_n - \zeta_n) \sin^2\theta_2] + h[c_1 \xi_n^2 + c_2 (\xi_n - \zeta_n)^2], \tag{22}$$

where

$$a = \frac{1}{2} - \frac{\sin 2\theta_2 - \sin 2\theta_1}{4(\theta_2 - \theta_1)}.$$

The critical condition for the phase transition HS-SD is that the dominant part of $\min \delta^2 F$ must vanish, i.e., $\min \tilde{\Delta}_{4,n} = \Delta_{4,n} = 0$. The minimum condition for $\tilde{\Delta}_{4,n}$ is given by a system of three equations $\partial_{\gamma_n} \tilde{\Delta}_{4,n} = \partial_{\xi_n} \tilde{\Delta}_{4,n} = \partial_{\zeta_n} \tilde{\Delta}_{4,n} = 0$:

$$a\gamma_n - (b_1 - b_2)\xi_n - b_2 h \zeta_n = 0, \tag{23}$$

$$-(b_1 - b_2)\gamma_n + (c_1 + c_2)h\xi_n - c_2 h \zeta_n = 0, \tag{24}$$

$$-b_2 \gamma_n - c_2 h \xi_n + (c_2 h + 1)\zeta_n = 0, \tag{25}$$

where

$$b_1 = (1-p)\sin^2\theta_1, \quad b_2 = (1-p)\sin^2\theta_2. \tag{26}$$

The necessary and sufficient condition for the solvability of the system (23)–(25) is that its determinant D must vanish. It is known that for $D=0$ the solution of the system can be found from any two equations, while the third one is satisfied identically. From (24) and (25), we find that

$$\xi_n = \alpha\gamma_n, \quad \zeta_n = \beta\gamma_n,$$

$$\alpha = (b_1 - b_2 + b_1 c_2 h)\lambda, \tag{27}$$

$$\beta = (c_1 b_2 + c_2 b_1)\lambda,$$

$$\lambda^{-1} = h(c_1 c_2 h + c_1 + c_2).$$

Having observed that the left-hand side of (23) times γ_n reproduces $\tilde{\Delta}_{4,n}$ and making use of (27), we find the minimum value $\Delta_{4,n}$ of the quadratic form to be given by

$$\Delta_{4,n} = \min \tilde{\Delta}_{4,n} = \lambda D \gamma_n^2 n^2. \tag{28}$$

For $D=0$, we have $\min \tilde{\Delta}_{4,n} = 0$; however, (28) is meaningful for $D \neq 0$ too. Indeed, if $\lambda D < 0$, $\Delta_{4,n}$ (28) has no minimum with respect to the variable γ_n , since (28) is not bounded from below and hence the equation $\partial_{\gamma_n} \tilde{\Delta}_{4,n} = 0$ no longer describes the behavior of the system and must be rejected. The other two equations, whose solution (27) was employed in the derivation of (28), are still valid and hence (28) also holds for $D \neq 0$. As for the minimum with respect to γ_n , it should be sought with regard for terms

of order γ_n^4 which bound $\Delta_{4,n}$ from below. It will be done below.

It is clear from (28) that $D=0$ corresponds to the onset of the phase transition. Inasmuch as λ given by (27) does not vanish (see Appendix B), we conclude that the critical condition for $h > h_a$ is the equality $D=0$ which may be reduced to

$$D = Ah^2 + Bh - (b_1 - b_2)^2 = 0, \quad (29)$$

where

$$A = ac_1c_2,$$

$$B = a(c_1 + c_2) - (1-p)^2(c_2\sin^4\theta_1 + c_2\sin^4\theta_2).$$

We remind the reader that the quantities $\theta_s = \theta_s(h, W_1, W_2, K)$ entering (26) and (29) are the solutions of Eq. (3); therefore (29) is not only the quadratic equation for h_c : the critical layer thickness h_c can be found by solving Eqs. (3) and (29). The numerical solutions of this system will be given below, and now we consider the term $\Delta_6\chi^6$ in ΔF , which is necessary in order to study the behavior of χ , ψ , and ϕ near the critical point. In particular, the critical behavior of χ determines the very important observable dependence of the period $L = 2\pi h \chi^{-1}$ on the layer thickness.

It should be noted that the order-of-magnitude relations (14) and (15) correspond to the case when the K_{24} term is one of the leading terms in the FE. In the general case, however, it is not the only possibility when perturbations with $\chi \ll 1$ can appear in the HNL. It is evident that negativity of c_s can in principle cause not only appearance of constant (y -independent) components of $\psi_0(z)$ above the threshold h_a , which, as we have already mentioned, are contained in the HS, but also the SD, which is evident from expression (7) for $\delta^2 F$. Indeed the transition at the point $h = h_a$ is given rise to by the terms $\psi_0^2 + \sum_s c_s \psi_{0,s}^2$, which are eliminated from the perturbation FE, but an analogous contribution is given by any perturbation harmonic, $\psi_n^2 + \sum_s c_s \psi_{n,s}^2$. However, we show in Appendix B that the assumption $\chi \ll 1$ is not confirmed *a posteriori* in the vicinity of h_a . This means that the wave number χ is not small in the thickness range $h \approx h_a$ and the value h_a is not the critical thickness for the SD state. Thus h_a is the critical value only for the transition $\theta_1 = \theta_2 \rightarrow \theta_1 > \theta_2$ within the HS. It is also shown in Appendix B that the two situations—the one described by (14) and (15), and the one considered in Appendix B—exhaust all the possibilities for the SD with $\chi \ll 1$ to appear in the HNL.

III. BEHAVIOR OF THE SYSTEM NEAR THE DOMAIN STATE FORMATION POINT

It is clear that the critical region is determined by small $\lambda D < 0$ in the vicinity of the critical point $D=0$. We are interested in the first three terms of the expansion of ΔF in power series of χ . With (20) and (21) being substituted into ΔF (5) for g_n and f_n , respectively, no terms containing odd powers of χ arise. Hence the expansion is given by

$$\Delta F = \left[\frac{K}{4\pi h} \right] [\Delta_4 \chi^4 + \Delta_6 \chi^6 + O(\chi^8)]. \quad (30)$$

The contributions in the second term come from the second, fourth, and fifth addends of $\delta^2 F$ (9) and the leading terms of the fourth variation; the contribution of the second addends $\bar{g}_{n,3}$ and $\tilde{f}_{n,4}$ of expansions (20) and (21) to the sum of leading terms starts at values of order $D\chi^6$, which are considerably smaller than the terms of order χ^6 due to the smallness of D (these terms are proportional to χ^8 since, as we shall see, $D \propto \chi^2$).

The coefficients in the expressions for ξ_n and ζ_n , as well as the critical condition $D=0$ for the appearance of the n th harmonic, do not depend on n . Therefore, if one employs only $\delta^2 F$, all the harmonics behave independently. The difference in the behavior of different harmonics is due to their mutual interactions, which are described by nonlinear (nonquadratic with respect to ϕ and ψ) terms in $\delta^4 F$. Interactions between an infinite number of harmonics cannot be treated in the Fourier representation, so we return to the coordinate representation.

In what follows we show that near the critical point similarly to the quantities ξ_n and ζ_n , the functions $\bar{g}_{n,3}(z)$ and $\tilde{f}_{n,4}(z)$ from (20) and (21) are proportional to γ_n , which contains the whole n dependence of these functions.

In Appendix C, the constant $\gamma'_n = \gamma'_{n,3} + (\chi n) \gamma'_{n,4}$ [see (16)] is found to be equal to $\gamma'_n = \gamma'_3 \gamma_n$, where γ_3 does not depend on n . Hence it follows from (16), (17), and (27) that $\bar{g}_{n,3} = \gamma_n g_3(z)$ and $\tilde{f}_{n,4} = \gamma_n f_4(z)$; the functions g_3 and f_4 , given in (C5) and (C6), are also n independent.

We introduce a more suitable variable $u = qy$ instead of y ; then

$$\begin{aligned} \phi(u, z) &= \sum_{n=1}^{\infty} [\chi n + \chi^3 n^3 g_3(z)] \gamma_n \cos nu \\ &= \chi G + \chi^3 g_3(z) G'', \end{aligned} \quad (31)$$

where $G = G(u)$ is defined by its Fourier transformation

$$G(u) = \sum_{n=1}^{\infty} n \gamma_n \cos nu, \quad (32)$$

and the primes of the symbol G denote derivatives of G over u . Now we reproduce $\psi(u, z)$:

$$\begin{aligned} \psi(u, z) &= \sum_{n=1}^{\infty} [(\alpha - \beta z) n^2 \chi^2 + n^4 \chi^4 f_4(z)] \sin nu \\ &= -\chi^2 (\alpha - \beta z) G' - \chi^4 f_4(z) G'''. \end{aligned} \quad (33)$$

Thus we have managed to express ϕ and ψ in terms of the single function $G(u)$ and its derivatives. Now we have to express Δ_4 and Δ_6 in terms of these, substitute the result in (30), and thus obtain ΔF (5) with accuracy up to terms $O(\chi^8)$ as a functional of G and its derivatives.

The leading part $\Delta_4 = \sum_n \Delta_{4,n}$, where $\Delta_{4,n}$ is given by (28). In terms of G , it takes the form

$$\chi^4 \Delta_4 = \lambda D \chi^4 \int_0^{2\pi} du G'^2. \quad (34)$$

The leading part of the fourth variation, proportional to

χ^6 , is given by

$$\begin{aligned} \frac{1}{4!} \delta^4 F &= -\frac{K}{4\pi h} \int_0^{2\pi} du \left[\sum_{s=1,2} \frac{\nu_s}{3} (1-p) \chi (\sin^2 \theta \psi_u \phi^3)_s + \frac{\tau \chi^2}{4} \int_0^1 dz \sin^2 \theta \phi^2 \phi_u^2 \right] \\ &= -\frac{K}{4\pi h} \int_0^{2\pi} du \left[\sum_{s=1,2} \nu_s (1-p) (\sin^2 \theta (\alpha - \beta))_s + \frac{\tau}{4} \int_0^1 dz \sin^2 2\theta \right] G^2 G'^2 \chi^6. \end{aligned} \quad (35)$$

It is not difficult also to express the terms $\Delta'_6 \chi^6$ entering the second variation in terms of G , i.e.,

$$\begin{aligned} \Delta'_6 \chi^6 &= \frac{K}{4\pi h} \int_0^{2\pi} du \int_0^1 dz [t(\alpha - \beta z)^2 \\ &\quad + \sin^2 \theta (1 - \tau \sin^2 \theta) g_3'^2 \\ &\quad - 2\tau g_3' \sin^2 \theta (\alpha - \beta z)] G''^2 \chi^6. \end{aligned} \quad (36)$$

Adding the expressions (34)–(36), we find the functional $\Delta F\{G\}$ which, with accuracy up to $O(\chi^8)$, is equal to ΔF (5):

$$\Delta F\{G\} = \frac{K}{4\pi h} \int_0^{2\pi} du [\chi^4 \lambda D G'^2 + \chi^6 (P G''^2 + Q G^2 G'^2)]. \quad (37)$$

The u -independent coefficients P and Q are given by the formulas

$$P = \int_0^1 dz \left[t(\alpha - \beta z)^2 + \frac{[a(z) + \gamma_3']^2 - \tau^2 \sin^4 \theta (\alpha - \beta z)^2}{\sin^2 \theta (1 - \tau \sin^2 \theta)} \right], \quad (38)$$

$$Q = -(1-p)[(\alpha - \beta) \sin^2 \theta_2 - \alpha \sin^2 \theta_1]$$

$$- \frac{\tau}{8} \left[1 - \frac{\sin^4 \theta_2 - \sin^4 \theta_1}{4(\theta_2 - \theta_1)} \right]. \quad (39)$$

We remind the reader that α, β (27) and the functions $a(z)$ (C1), $g_3(z)$ (C5), and the constant γ_3' (C6) are unambiguously determined by the angles θ_1 and θ_2 of the non-perturbed HS on the HNL surfaces.

The functional $\Delta F\{G\}$ contains contributions from all the harmonics G_n and, in principle, together with (31) and (33), makes it possible to solve completely the problem of the HS-SD phase transition. However, we did not manage to solve the Euler-Lagrange equations for the functional (37), given by

$$\chi^2 P G'''' - (D\lambda + \chi^2 Q G^2) G''' - \chi^2 Q G G'^2 = 0. \quad (40)$$

Nevertheless, $\Delta F\{G\}$ enables us to find any number of harmonics of the function G . For example, substituting one harmonic $G = G_1 \cos u$ in (37) and minimizing with respect to G_1 and χ yield

$$\begin{aligned} G_1 &= \left[\frac{4P}{Q} \right]^{1/2}, \quad \chi = \left[-\frac{D\lambda}{3P} \right]^{1/2}, \\ P &> 0, \quad Q > 0, \quad \lambda D \leq 0, \\ \phi(y, z) &= G_1 [\chi - \chi^3 g_3(z)] \cos(\chi y h^{-1}), \\ \psi(y, z) &= G_1 [\chi^2 (\alpha - \beta z) - \chi^4 f_4(z)] \sin(\chi y h^{-1}). \end{aligned} \quad (41)$$

These expressions, together with the relations $\mathbf{n}' = \mathbf{n} + \delta \mathbf{n}$ and $\delta \mathbf{n} = (\psi \cos \theta, \phi \sin \theta, -\psi \sin \theta)$ determine the SD state in the one-harmonic approximation.

Thus, if the critical condition is satisfied, i.e., Eqs. (3) and (27) have a joint solution, the HS-SD transition occurs, in which deformations of all the three types appear, and among them two twists: one about the z axis with the amplitude $\propto (-D)^{3/2}$, which slowly grows in the transcritical region, and another about the y axis, whose amplitude is proportional to $(-D)^{1/2}$ and grows much more steeply. The chiral symmetry of the HS in the HNL is spontaneously violated. Similarly to the twist about the y axis, the splay deformation grows as $\chi \cos(\chi y/h) \propto (-D)^{1/2}$. These two deformations are the leading ones in the SD state, and their product determines the dominant negative term in the FE, which is proportional to $(K - 2K_{22} - 2K_{24})$ and enters its surface part. Though a part of this term is contained in the standard Frank density [see (6)], functionally it reproduces the K_{24} term and we can say that the existence of SD with period $L \gg h$ in the HNL is the effect produced by the K_{24} term in the nematic FE.

IV. NUMERICAL RESULTS AND DISCUSSION

Equations (3) and (29) determined θ_1, θ_2 , and the critical thickness h_c , below which SD's with $L \gg h$ are formed in the HNL. These equations were solved numerically for $W_1 = 10^{-5} \text{ J m}^{-2}$, $W_2 = 4.5 \times 10^{-6} \text{ J m}^{-2}$, $K = 10^{-11} \text{ N}$, and $t = K_{22}/K = 0.5$. These typical values of the anchoring energy and elastic constants were taken from Ref. [9]. The dependences $D(h)$ (29) and $\chi(h)$ (41), as well as $L(h)$, are shown in Figs. 2(a) and 2(b) for $1-p = 0.6$ and in Figs. 3(a) and 3(b) for $1-p = 1$. As follows from the figures, $h_c = 1.4 \text{ } \mu\text{m}$ for $1-p = 0.6$ and $h_c = 1.7 \text{ } \mu\text{m}$ for $1-p = 1$. In the interval $h_a = 1.22 \text{ } \mu\text{m} < h_c - \Delta h < h < h_c$, χ is small and our theory is applicable; for this range of thicknesses, the equilibrium HNL state is the domain state with large period. Only in this range does the measured dependence $L(h)$ allow us, in principle, to estimate the constant K_{24} (unfortunately, the HNL thickness was not measured with the required accuracy in the experiments [9]).

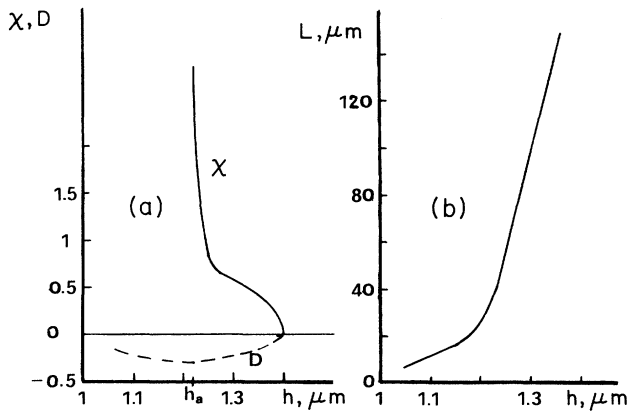

FIG. 2. Numerical results for $1-p=0.6$. (a) The determinant D (29) and the wave number χ (41) as functions of the HNL thickness h in the vicinity of the HS-SD transition. (b) The domain period L vs h near the transition point. The small χ approximation, for which these results are valid, holds for thicknesses $h > h_c - \Delta h > h_a$, where $h_c = 1.4 \mu\text{m}$ and Δh can be estimated as $0.05 \mu\text{m}$.

When h approaches $h_a = 1.22 \mu\text{m}$, the wave number first increases up to one and then diverges. In this region, our theory employing the expansion in small parameter series becomes invalid. The divergence of χ for $h = h_a = K(W_1^{-1} - W_2^{-1})$ occurs because the quantity

$$\lambda^{-1} = c_1 c_2 h^2 + (c_1 + c_2)h \\ \propto h - K[(W_1 \cos 2\vartheta_1)^{-1} - (W_2 \cos 2\vartheta_2)^{-1}]$$

[see (41) and (27)] vanishes for this value of h ; $\lambda^{-1} > 0$ and hence $D < 0$ for $h > h_a$. The equation $\lambda^{-1} = 0$ exactly reproduces the condition for the transition $\theta_1 > \theta_2 \rightarrow \theta_1 = \theta_2 = \pi/2$ to occur in the HNL (see Appendix B). The growth of χ near this transition shows that, for relevant thicknesses $h \approx h_a$, the K_{22} mechanism is important and the domain structures are short wavelength.

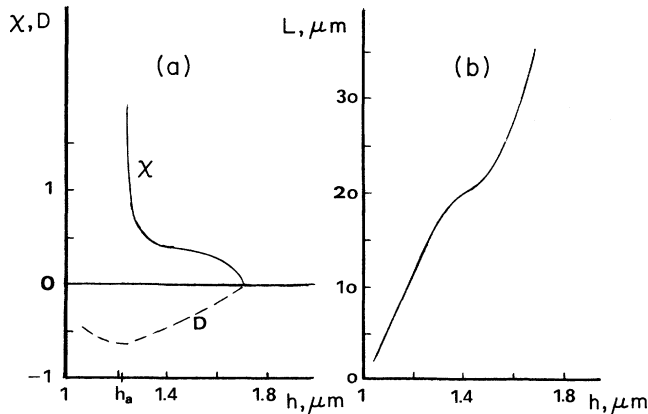

FIG. 3. The dependence of Fig. 2 for $1-p=1$. $h_c = 1.7 \mu\text{m}$, $\Delta h \approx 0.3 \mu\text{m}$.

The SD's appear in the HNL for any nonzero $1-p$; however, the greater $|1-p|$, the greater the interval Δh in which the long-wavelength SD's appear; for $1-p=0$, h_c coincides with h_a .

We note once more that h_c does not depend on $t = K_{22}/K$; t enters only $\chi(h)$ and $L(h)$ through the t dependence of the FE terms of order χ^6 [see (39)]. For given $(K_{22} + K_{24})/K$ or $1-p$, we would obtain the same h_c for $t=1$ or $K_{22}=K$, when the bulk free energy is isotropic. Thus the long-wavelength SD's appear in a HNL for any ratio $t = K_{22}/K$. As for the short-wavelength SD with $\chi \approx 1$ and $L \approx 2\pi h$, according to our estimates they would appear for the thickness range $h \lesssim h_a$ if t is sufficiently small, namely, $t < 0.5$. This allows one to assume that if one deals with the wedge-shaped HNL whose upper surface is slightly inclined with respect to the lower one, then SD's with different periods L ought to be observed. For $K_{22}/K = 0.5$, the SD's begin from large periods $L \gg h$ for $h = h_c$, then L gradually decreases with the decrease of h , and then the domains disappear in the middle-wavelength range for some certain h_d , $h_a < h_d < h_c$, since the short-wavelength SD's cannot occur for such large K_{22}/K . The other situation will take place for $K_{22}/K < 0.5$. In this case, the SD period begins from a large value for $h = h_c$ again, but can vary continuously up to values of the order of h for $h \lesssim h_a$ when the wedge is getting thinner, since the short-wavelength SD's can occur for this range of thicknesses. In the first case h_a does not belong to the interval of thickness where SD's exist whereas in the last case it does, $h_d < h_a < h_c$.

The SD's have been discovered precisely in such wedge-shaped HNL [9]. Though the exact profile of the wedge is unknown, the relation between the periodicity character and the ratio $t = K_{22}/K$ predicted above is confirmed reliably. In the wedge-shaped HNL of the nematic "mixture A" with $t = 0.7$, for thicknesses of the order of $h \lesssim 1 \mu\text{m}$, SD's have been observed whose period varied in the range $30 < L < 150 \mu\text{m}$ [9]. These SD's are certainly not short wavelength, and hence do not appear for $h \lesssim h_a$. At the same time, in similar HNL of 5CB [4-(*n*-pentyl)-4'-cyanobiphenyl], whose $t = 0.45$ ($K_{22}/K_{11} = 0.5$, $K_{22}K_{33} = 0.4$), the SD period varied in the range $2 < L < 25 \mu\text{m}$ [9], which shows explicitly that both the long-wavelength SD's and the short-wavelength SD's are possible in this nematic. As for the lower thickness boundary h_d below which the SD's do not occur, in the vicinity of this thickness the assumption $\chi \ll 1$ is only marginally valid for $t > 0.5$ and it is clearly violated for $t < 0.5$. Moreover, it is shown in Ref. [16] that in order to find the value of h_d , one has to take into account the azimuthal anchoring energy. This anchoring, however, must be associated with the preferential direction on the HNL surfaces given rise to by the wedge shape of HNL rather than with the anisotropy of the surfaces themselves, which are isotropic (see Introduction). Evidently, such "geometrical" [24] anchoring is ineffective in the area where the variation of the value $|\theta_1 - \theta_2|$ due to the variation of HNL thickness is much smaller than that along the z axis, i.e., if $|\partial(\theta_1 - \theta_2)/\partial x| \ll |\partial\theta/\partial z|$, where

the x axis is directed along the wedge. If the wedge angle is very small the derivative $|\partial(\theta_2 - \theta_1)/\partial x|$ is very small too, so the effective azimuthal anchoring is effective for very small $\partial\theta/\partial z$. It is clear that $\partial\theta/\partial z$ becomes small just for $h \approx h_a$ when $\theta_1 - \theta_2 \rightarrow 0$, therefore, such anchoring can come into play only for short-wavelength (and, possibly, for middle-wavelength) SD's. This is the reason why it can be ignored in the theory of the long-wavelength SD's worked out in this paper.

Thus for $h < h_c$ twist can occur irrespective of the value of twist elastic constant. This shows that the K_{24} mechanism of twist formation in the nematic is a qualitatively new one and, as distinct from the K_{22} mechanism, it is irrespective of the anisotropy of the elastic constants entering the Frank part of the nematic free energy. That is why the K_{24} mechanism can cause analogous effects in other condensed media with symmetry-allowed K_{24} terms but with weaker anisotropy with respect to deformations of various types than liquid crystals, or isotropic. An example is the B phase of liquid helium ^3He , for which the K_{24} term can be introduced explicitly [19], or a ferromagnet, in which this term can be introduced [18] but is ignored for the reasons discussed in the Introduction. Of course, the dominant role belongs to the sample geometry: it must be associated with sufficiently large surface-to-volume ratio.

In conclusion, we want to emphasize that the theory incorporating all the harmonics of the SD structure can be important in many cases when periodic perturbations appear with zero wave number χ at the start of the transition. Indeed, according to the theorem proved in Appendix 3 of Ref. [25], all the harmonics are excited if $\chi=0$ at the critical point, and the state which appears above the threshold is a periodic soliton rather than a monochromatic SD wave (whereas if χ is finite at the transition point, only one harmonic appears). Then, if transformations of just such periodic structures are studied themselves, more detailed information about this state is necessary than that contained in the one harmonic approximation. For example, if the SD's interact with some external field that is able to cause their transformation (instability), Eq. (40) must be solved to determine the basic SD state with the accuracy needed. We hope to present such a study in the near future.

ACKNOWLEDGMENTS

The author would like to thank A. V. Lobov, T. J. Sluckin, and P. I. C. Teixeira for useful discussions and A. V. Lobov for assistance in performing numerical computations. Part of this work was carried out at Southampton University, where the author visited and was supported by SERC under Grant No. GR/H70317.

APPENDIX A

The Euler-Lagrange equations impose the symmetry of the FE functional on the director distribution minimizing it. Here we employ the symmetry of the functional ΔF (5) to simplify representations (8) for ψ and ϕ .

The FE $\Delta F = \frac{1}{2}\delta^2 F + (1/4!)\delta^4 F$ [evidently, $\delta^3 F$ identi-

cally vanishes for periodical ψ and ϕ given by (8)] where $\delta^2 F$ and $\delta^4 F$ are given by formulas (7) and (35), must be invariant with respect to the transformation $y \rightarrow -y$, which gives the following equations:

$$\phi^2(y) = \phi^2(-y), \quad (\text{A1a})$$

$$\psi^2(y) = \psi^2(-y), \quad (\text{A1b})$$

$$(\psi_y \phi)(-y) = (\psi_y \phi)(y), \quad (\text{A1c})$$

$$(\psi_y \phi^3)(-y) = (\psi_y \phi^3)(y), \quad (\text{A1d})$$

$$(\phi_y^2 \phi^2)(y) = (\phi_y^2 \phi^2)(-y). \quad (\text{A1e})$$

Representation of each function $A(y)$ as a sum of even $A_+(y)$ and odd $A_-(y)$ parts, $A = A_+ + A_-$, enables us to reduce equations (A1a), (A1b), and (A1c) to the following forms, respectively:

$$\phi_+ \phi_- = 0, \quad (\text{A2})$$

$$\psi_+ \psi_- = 0, \quad (\text{A3})$$

$$(\psi_y)_+ \phi_- + (\psi_y)_- \phi_+ = 0, \quad (\text{A4})$$

while (A1d) and (A1e) give no new equations as compared with (A2)–(A4).

Three possible solutions of this system are

$$\phi_+ = \phi_- = 0, \quad (\text{A5})$$

$$(\psi_y)_+ = (\psi_y)_- = 0, \quad (\text{A6})$$

$$\psi_+ = \phi_- = 0, \quad (\text{A7})$$

$$\psi_- = \phi_+ = 0.$$

The first solution corresponds to $\phi=0$ and $\psi=0$ and therefore is unsatisfactory. The next two respectively imply either vanishing f_n and g_n or r_n and p_n in formula (8), so we can choose any of these pairs to describe the order parameters ϕ and ψ . In this paper, we have chosen the pair (f_n, g_n) while $r_n = p_n = 0$. Thus ϕ is an even function of y while ψ is an odd one.

APPENDIX B

In Sec. III we analyzed the case when the expansion of f_n in power series of χ begins with χ^2 . One more possibility exists: to consider the term $f_{n,1}$. We shall do it here.

Substituting the series $f_n = (n\chi)f_{n,1} + \dots$ and $g_n = (n\chi)g_{n,1} + \dots$ in (9) yields the first three terms of the FE expansion in power series of χ :

$$\Delta F = \frac{K}{4\pi h} \sum_n [\Delta_{2,n}(\chi n)^2 + \Delta_{3,n}(\chi n)^3 + \Delta_{4,n}(\chi n)^4], \quad (\text{B1})$$

where

$$\begin{aligned} \tilde{\Delta}_{2,n} &= f_{n,1}'^2 + c_1 f_{n,1}^2(1) + c_2 f_{n,1}^2(2), \\ \Delta_{3,n} &= 2(1-p) \sum_{s=1,2} \nu_s (\sin^2 \theta f_{n,1} g_{n,1})_s. \end{aligned} \quad (\text{B2})$$

Here we have taken into account that the z dependence of

$g_{n,1}$ results in a positive contribution $\propto g_{n,1}^2$ to the principal part $\tilde{\Delta}_{2,n}$ of ΔF , so $g_{n,1}$ is taken to be z independent. There is no need to consider the term $\Delta_{4,n}$ here; we just emphasize that the term $\propto \psi^4$ from $\delta^4 F$ contributes to it. Thus retaining the first term in the expansion of f_n in a power series of χ makes the first kind of phase transition possible, the critical condition being $\min \tilde{\Delta}_{2,n} = 0$. Since $f_{n,1}$ satisfies Eq. (10) as before, we have

$$f_{n,1} = \xi_{n,1} - \zeta_{n,1} z. \quad (\text{B3})$$

Substituting (B3) into (B2) and minimizing the quadratic form obtained with respect to $\xi_{n,1}$ and $\zeta_{n,1}$ yields

$$\xi_{n,1} - h(\xi_{n,1} - \zeta_{n,1})c_2 = 0, \quad (\text{B4})$$

$$c_2 h \zeta_{n,1} - h(c_2 + c_1)\xi_{n,1} = 0.$$

Similarly to (27) and (28), these formulas determine the relation between $\xi_{n,1}$ and $\zeta_{n,1}$ at the critical point and the minimum value of the quadratic form $\Delta_{2,n}$, i.e.,

$$\xi_{n,1} = \frac{c_2}{c_1 + c_2} \zeta_{n,1}, \quad (\text{B5})$$

$$\Delta_{2,n} = \min \tilde{\Delta}_{2,n} = \frac{\xi_{n,1}^2}{h^2(c_1 + c_2)} \lambda^{-1}, \quad (\text{B6})$$

where λ^{-1} , given by (27), is the determinant of system (B4). We remind the reader that $\theta_s = \theta_s(z, h)$ and hence the equation $\lambda^{-1} = 0$ is transcendental with respect to h . Numerical computation shows that its solution exists only for $h = h_a = K[(1/W_2) - (1/W_1)]^{-1}$, when $\theta_1 = \theta_2 = \pi/2$. Moreover, when $h \neq h_a$, the coefficient before $\xi_{n,1}^2$ is positive, $\Lambda = \lambda^{-1}(c_1 + c_2)^{-1} > 0$; $\Lambda(h)$ vanishes only for $h = h_a$. Therefore we deal with the FE of the following form:

$$\Delta F_h = \frac{K}{4\pi h} [\Delta_{2,n}(\chi n)^2 + \Delta_{3,n}(\chi n)^3 + \Delta_{4,n}(\chi n)^4] \quad (\text{B7})$$

where $\Delta_{2,n} \geq 0$ and $\Delta_{3,n} < 0$. Assuming $h \approx h_a$ and hence $\Delta_{2,n} \ll 1$, and also $\Delta_{4,n} > 0$ (otherwise $\chi \rightarrow \infty$), we find χ , corresponding to $\min \Delta F$, to be

$$\chi n = \frac{\sigma |\Delta_{3,n}| - (16\Delta_{2,n}\Delta_{4,n})(3|\Delta_{3,n}|)^{-1}}{8\Delta_{4,n}}. \quad (\text{B8})$$

According to (B8), χ is not small even for $h = h_a$ when $\Delta_{2,n} = 0$, since $\Delta_{3,n}$ does not vanish together with $h - h_a$. Thus the assumption that the SD's with $\chi \ll 1$ occur in a HNL near the point $h = h_a$ is not confirmed *a posteriori*;

(B8) rather confirms our estimation, derived in Sec. III, that only the short-wavelength SD can occur for $h \approx h_a$. However, the point $h = h_a$ itself does not play the role of any critical point which can be associated with a SD structure.

Thus the phase transition to the state with $\chi \ll 1$, found in Sec. III, is unique, and all other possibilities correspond to $\chi \approx 1$ when, according to our results, the K_{24} and K_{22} mechanisms work together.

APPENDIX C

Let us find the constants $\gamma'_{n,3}$ and $\gamma'_{n,4}$ [to be more exact, their sum $\gamma'_n = \gamma'_{n,3} + (\chi n)\gamma'_{n,4}$, which determines the variable $\bar{g}_{n,3}(z)$ introduced in (19)]. According to (17), the function $\tilde{f}_{n,4}$ contains $\gamma'_{n,3}$; however, replacing $\gamma'_{n,3}$ by the sum γ'_n results in the error of order $O(\chi^8)$, so we can do it without introducing inaccuracy. The functions $\bar{g}_{n,3}(z)$ enter the terms of the order of χ^6 in $\delta^2 F$ and γ'_n can be found from these by means of minimization.

We introduce the following functions:

$$a(z) = \frac{z}{2} - \frac{\sin 2\theta(z) - \sin 2\theta_1}{4(\theta_2 - \theta_1)},$$

$$I(z) = \int_0^z dz [\sin^2\theta(1 - \tau \sin^2\theta)]^{-1}, \quad (\text{C1})$$

$$J_1(z) = \int_0^z dz a(z) [\sin^2\theta(1 - \tau \sin^2\theta)]^{-1},$$

$$J_2(z) = \int_0^z dz [\alpha - \beta z + a(z)] [\sin^2\theta(1 - \tau \sin^2\theta)]^{-1}.$$

Then the result of the free energy minimization with respect to γ'_n may be written as

$$\gamma'_n = \gamma'_3 \gamma_n, \quad (\text{C2})$$

$$\gamma'_3 = -\frac{J_1(1)}{I(1)}. \quad (\text{C3})$$

By virtue of (C2), functions $\bar{g}_{n,3}(z)$ and $\tilde{f}_{n,4}(z)$, given by (16)–(19), also can be expressed in terms of γ_n , i.e.,

$$\bar{g}_{n,3}(z) = \gamma_n g_3(z), \quad \tilde{f}_{n,4}(z) = \gamma_n f_4(z), \quad (\text{C4})$$

$$g_3(z) = J_2(z) + \gamma'_3 I(z), \quad (\text{C5})$$

$$f_4(z) = t \left[\alpha \frac{z^2}{2} - \beta \frac{z^3}{6} \right] - \tau \int_0^z dz [J_2(z) + \gamma'_3 I(z)]. \quad (\text{C6})$$

These formulas are essential for deriving the functional $\Delta F\{G\}$.

*Permanent address.

- [1] C. W. Oseen, Trans. Faraday Soc. **29**, 883 (1933).
- [2] F. C. Frank, Discuss. Faraday Soc. **25**, 19 (1958).
- [3] J. Nehring and Saupe, J. Chem. Phys. **54**, 337 (1971).
- [4] A. Strigazzi, Nuovo Cimento D **10**, 1335 (1988).
- [5] L. M. Blinov, E. I. Kats, and A. A. Sonin, Usp. Fiz. Nauk **152**, 449 (1987) [Sov. Phys. Usp. **30**, 604 (1987)].
- [6] F. Lequeux and M. Kléman, J. Phys. (France) **49**, 845 (1988).

- [7] V. M. Pergamenschchik, Ukrain. Fiz. Zh. (Russ. Ed.) **35**, 1352 (1990).
- [8] G. Barbero, A. Sparavigna, and A. Strigazzi, Nuovo Cimento D **12**, 1259 (1990).
- [9] O. D. Lavrentovich and V. M. Pergamenschchik, Mol. Cryst. Liq. Cryst. **179**, 125 (1990).
- [10] V. H. Schmidt, Phys. Rev. Lett. **64**, 535 (1990).
- [11] O. D. Lavrentovich, Phys. Scr. **T39**, 394 (1991).
- [12] D. W. Allender, G. P. Crawford, and J. W. Doane, Phys.

- Rev. Lett. **67**, 1442 (1991).
- [13] E. Lonberg and R. B. Meyer, Phys. Rev. Lett. **55**, 718 (1985).
- [14] O. D. Lavrentovich and Yu. A. Nastishin, Europhys. Lett. **12**, 135 (1990).
- [15] O. D. Lavrentovich, Mol. Cryst. Liq. Cryst. **191**, 77 (1990).
- [16] A. Sparavigna, L. Komitov, B. Stebler, and A. Strigazzi, Mol. Cryst. Liq. Cryst. **207**, 265 (1991).
- [17] G. Barbero and R. Barberi, J. Phys. (France) **44**, 609 (1983).
- [18] L. D. Landau and E. M. Lifshits, *Elektrodinamika Sploshnykh Sred*, 2nd ed. (Nauka, Moscow, 1982).
- [19] P. W. Anderson and W. F. Brinkman, in *The Helium Liquids*, edited by J. G. M. Armitage and I. E. Farquar (Academic, New York, 1975), Chap. 8, p. 315; S. S. Rozhkov, Usp. Fiz. Nauk **148**, 325 (1986) [Sov. Phys. Usp. **29**, 186 (1986)].
- [20] L. D. Landau and E. M. Lifshitz, *Teoriya Uprugosti*, 4th ed. (Nauka, Moscow, 1987).
- [21] S. Meiboom, M. Sammon, and W. F. Brinkman, Phys. Rev. A **27**, 438 (1983).
- [22] J. L. Eriksen, Phys. Fluids **9**, 1205 (1966).
- [23] We assume the Fourier series for ϕ and ψ to be rapidly convergent for large n due to steep decrease of the harmonics f_n and g_n , so that for sufficiently small χ one can neglect the harmonics for which $n\chi \approx 1$.
- [24] O. D. Lavrentovich, Phys. Rev. A **46**, 722 (1992).
- [25] O. D. Lavrentovich, V. G. Nazarenko, V. M. Pergamenshchik, V. V. Sergan, and V. M. Sorokin, Zh. Exp. Teor. Fiz. **99**, 777 (1991) [Sov. Phys. JETP **72**, 431 (1991)].