

Real space CMB temperature and polarization formulas

M. Landriau*

*McDonald Observatory, 2515 Speedway, Stop C1402, Austin, Texas 78712, USA,
and Lawrence Berkeley National Laboratory, 1 Cyclotron Road, Mailstop 50R5008,
Berkeley, California 94720, USA*

(Received 4 March 2016; published 5 August 2016)

I derive formulas for the real space CMB temperature and polarization by solving the first order Boltzmann equation for the Stokes parameters I , Q and U .

DOI: 10.1103/PhysRevD.94.043504

I. INTRODUCTION

Most studies of the CMB that use all the relevant physics to first order in the cosmological perturbations, i.e. by solving the first order Einstein-Boltzmann equations, limit themselves to working exclusively in harmonic space, in order to directly compute the power spectra, e.g. [1]. In real space, we have the Sachs-Wolfe formula for CMB temperature anisotropies, which was derived assuming instantaneous recombination [2]. Although there is an *ad hoc* way to take the finite duration of recombination into account, e.g. [3,4], the resulting formula is not exact, as it's missing a term, which has been known for some time (at least for scalar modes) from harmonic space computations, e.g. the seminal work of [5]. Studying maps of CMB fluctuations is desirable when one is interested in looking for localized features, which are not readily identifiable in power spectra. In [6], the full real space temperature equation was used to compute CMB temperature maps seeded by a network of cosmic strings. Here, I will present the proof of this formula as well as derive those for polarization.

II. THE BOLTZMANN EQUATION

We want to find real solutions to the first order Boltzmann equation for the Stokes parameters I , Q and U , which, following [7] we normalize in the following manner:

$$\begin{pmatrix} I \\ Q \\ U \end{pmatrix} = \frac{\rho_\gamma(\eta)}{4\pi} \begin{pmatrix} 1 + \Delta_I \\ \Delta_Q \\ \Delta_U \end{pmatrix}, \quad (1)$$

where ρ_γ is the photon energy density and η is the conformal time. The equations are then

$$\begin{aligned} \frac{\partial \Delta_I}{\partial \eta} + \hat{n} \cdot \nabla \Delta_I + 2\hat{n}_i \hat{n}_j \frac{\partial h_{ij}}{\partial \eta} &= \dot{\tau}(\tilde{\Delta}_I - \Delta_I + 4\hat{n} \cdot \mathbf{v}_b), \\ \frac{\partial \Delta_{Q,U}}{\partial \eta} + \hat{n} \cdot \nabla \Delta_{Q,U} &= \dot{\tau}(\tilde{\Delta}_{Q,U} - \Delta_{Q,U}), \end{aligned} \quad (2)$$

where \hat{n} is the direction of photon propagation, $\dot{\tau}$ is the differential Thompson cross section, \mathbf{v}_b and h_{ij} are the

baryon velocity and metric perturbations in the synchronous gauge and

$$\begin{pmatrix} \tilde{\Delta}_I(\hat{n}) \\ \tilde{\Delta}_Q(\hat{n}) \\ \tilde{\Delta}_U(\hat{n}) \end{pmatrix} = \int \mathcal{M}(\hat{n}, \hat{n}') \begin{pmatrix} \Delta_I(\hat{n}') \\ \Delta_Q(\hat{n}') \\ \Delta_U(\hat{n}') \end{pmatrix} d\Omega' \quad (3)$$

are the scattering terms. For the detailed form of the scattering matrix \mathcal{M} , the reader is referred to [7] or [4]; its derivation can be found in the classic monograph [8]. Going to Fourier space, the equations become

$$\begin{aligned} \dot{\Delta}_I + ik\mu\Delta_I + 2\dot{h}_{ij}\hat{n}_i\hat{n}_j &= \dot{\tau}(\tilde{\Delta}_I - (\Delta_I - 4\hat{n} \cdot \mathbf{v}_b)), \\ \dot{\Delta}_{Q,U} + ik\mu\Delta_{Q,U} &= \dot{\tau}(\tilde{\Delta}_{Q,U} - \Delta_{Q,U}), \end{aligned} \quad (4)$$

where $\mu = \cos \theta = \hat{n} \cdot \hat{k}$. These can then be formally integrated to yield

$$\begin{aligned} \Delta_I &= \int d\eta e^{-ik\mu(\eta_0-\eta)} e^{-\tau} (\dot{\tau}(\tilde{\Delta}_I + 4\hat{n} \cdot \mathbf{v}_b) - 2\dot{h}_{ij}\hat{n}_i\hat{n}_j), \\ \Delta_{Q,U} &= \int d\eta e^{-ik\mu(\eta_0-\eta)} e^{-\tau} \dot{\tau} \tilde{\Delta}_{Q,U}. \end{aligned} \quad (5)$$

To evaluate the scattering term, we split the $\Delta_{I,Q,U}$ into scalar, vector and tensor components, and factor out the dependence on the azimuthal angle φ , which is defined with respect to an arbitrary basis for the plane normal to \hat{k} , \hat{e}_1 and \hat{e}_2 that obey $\hat{e}_1 \times \hat{e}_2 = \hat{k}$, such that $\hat{e}_1 \cdot \hat{n} = \sin \theta \cos \varphi$ and $\hat{e}_2 \cdot \hat{n} = \sin \theta \sin \varphi$:

$$\begin{aligned} \Delta_I &= \Delta_I^S - i(1-\mu^2)^{\frac{1}{2}}(\Delta_I^{V1} \cos \varphi + \Delta_I^{V2} \sin \varphi) \\ &\quad + (1-\mu^2)(\Delta_I^{T+} \cos 2\varphi + \Delta_I^{T\times} \sin 2\varphi), \\ \Delta_Q &= \Delta_Q^S + \mu(1-\mu^2)^{\frac{1}{2}}(\Delta_Q^{V1} \cos \varphi + \Delta_Q^{V2} \sin \varphi) \\ &\quad + (1+\mu^2)(\Delta_Q^{T+} \cos 2\varphi + \Delta_Q^{T\times} \sin 2\varphi), \\ \Delta_U &= (1-\mu^2)^{\frac{1}{2}}(-\Delta_U^{V1} \sin \varphi + \Delta_U^{V2} \cos \varphi) \\ &\quad + 2\mu(-\Delta_U^{T+} \sin 2\varphi + \Delta_U^{T\times} \cos 2\varphi). \end{aligned} \quad (6)$$

*mlandriau@lbl.gov

We then expand the components into Legendre polynomials $\Delta(\mu) = \sum_{\ell} (-i)^{\ell} (2\ell + 1) \Delta_{\ell} P_{\ell}(\mu)$. Performing the integral (3), we obtain

$$\begin{aligned}\tilde{\Delta}_I &= \Delta_{I0}^S - \frac{1}{4}(3\mu^2 - 1)\Pi^S \\ &\quad + \mu(1 - \mu^2)^{\frac{1}{2}}(\Pi^{V1} \cos \varphi + \Pi^{V2} \sin \varphi) \\ &\quad - (1 - \mu^2)(\Pi^{T+} \cos 2\varphi + \Pi^{T\times} \sin 2\varphi), \\ \tilde{\Delta}_Q &= \frac{3}{2}(\mu^2 - 1)\Pi^S + \mu(1 - \mu^2)^{\frac{1}{2}}(\Pi^{V1} \cos \varphi + \Pi^{V2} \sin \varphi) \\ &\quad + (1 + \mu^2)(\Pi^{T+} \cos 2\varphi + \Pi^{T\times} \sin 2\varphi), \\ \tilde{\Delta}_U &= (1 - \mu^2)^{\frac{1}{2}}(\Pi^{V1} \sin \varphi - \Pi^{V2} \cos \varphi) \\ &\quad + (2\mu)(\Pi^{T+} \sin 2\varphi - \Pi^{T\times} \cos 2\varphi),\end{aligned}\quad (7)$$

with the components $\Pi^{S,V,T}$ defined as in Ref. [4]:

$$\begin{aligned}\Pi^S &= \Delta_{I2}^S + \Delta_{Q0}^S + \Delta_{Q2}^S, \\ \Pi^{Vi} &= -\frac{3}{10}\Delta_{I1}^{Vi} - \frac{3}{10}\Delta_{I3}^{Vi} + \frac{7}{20}\Delta_{Q0}^{Vi} + \frac{5}{28}\Delta_{Q2}^{Vi} - \frac{6}{35}\Delta_{Q4}^{Vi}, \\ \Pi^{Te} &= \frac{1}{10}\Delta_{I0}^{Te} + \frac{1}{7}\Delta_{I2}^{Te} + \frac{3}{70}\Delta_{I4}^{Te} - \frac{3}{5}\Delta_{Q0}^{Te} + \frac{6}{7}\Delta_{Q2}^{Te} - \frac{3}{70}\Delta_{Q4}^{Te}.\end{aligned}\quad (8)$$

By introducing the traceless tensor

$$\begin{aligned}\Pi_{ij} &= \frac{3}{4}\Pi^S(\hat{k}_i\hat{k}_j - \frac{1}{3}\delta_{ij}) \\ &\quad - \frac{1}{2}\Pi^{V1}(\hat{k}_i\hat{e}_{1j} + \hat{e}_{1i}\hat{k}_j) - \frac{1}{2}\Pi^{V2}(\hat{k}_i\hat{e}_{2j} + \hat{e}_{2i}\hat{k}_j) \\ &\quad + \Pi^{T+}(\hat{e}_{1i}\hat{e}_{2j} + \hat{e}_{2i}\hat{e}_{1j}) + \Pi^{T\times}(\hat{e}_{1i}\hat{e}_{1j} - \hat{e}_{2i}\hat{e}_{2j}),\end{aligned}\quad (9)$$

which I call the polarization tensor [9], and the vectors

$$\hat{u} = -\frac{\hat{k} - \mu\hat{n}}{\sin \theta}, \quad \hat{v} = \frac{\hat{k} \times \hat{n}}{\sin \theta}, \quad (10)$$

which form an orthonormal basis for the polarization plane (i.e. normal to \hat{n}), such that \hat{u} lies in the $\hat{n} - \hat{k}$ plane, we can simplify the equations for the scattering terms:

$$\begin{pmatrix} \tilde{\Delta}_I - \Delta_{I0}^S \\ \tilde{\Delta}_Q \\ \tilde{\Delta}_U \end{pmatrix} = \Pi_{ij} \begin{pmatrix} \hat{n}_i\hat{n}_j \\ \hat{u}_i\hat{u}_j - \hat{v}_i\hat{v}_j \\ \hat{u}_i\hat{v}_j + \hat{v}_i\hat{u}_j \end{pmatrix}. \quad (11)$$

Note that the triad \hat{n} , \hat{u} and \hat{v} corresponds to the standard spherical coordinate unit vectors \hat{r} , $\hat{\theta}$ and $\hat{\phi}$ with \hat{k} as the z -axis. Having determined the form of the scattering terms, we can now derive the real space formulas for the Stokes parameters.

III. CMB TEMPERATURE AND POLARIZATION

From the intensity part of Eqs. (5) and (11), the CMB temperature formula can immediately be obtained by Fourier transforming back to real space and using $\Delta T/T = \Delta_I/4$ and $\delta_{\gamma} = \Delta_{I0}$:

$$\frac{\Delta T}{T}(\hat{n}) = \int d\eta e^{-\tau} \left[\dot{\tau} \left(\frac{\delta_{\gamma}}{4} - \hat{n} \cdot \mathbf{v}_b + \frac{1}{4} \hat{n}_i \hat{n}_j \Pi_{ij} \right) - \frac{1}{2} \hat{n}_i \hat{n}_j \dot{h}_{ij} \right]. \quad (12)$$

This equation for the temperature fluctuations is essentially the Sachs-Wolfe formula modified to take into account the finite duration of decoupling with an added polarization term, $\frac{1}{4} \hat{n}_i \hat{n}_j \Pi_{ij}$. Note that we have changed the sign of \hat{n} , to change the perspective from photon propagation direction to line of sight.

For Q and U , it is not as simple as, unlike I , they are not invariant under rotations; they are transformed as

$$\begin{aligned}\Delta'_Q &= \Delta_Q \cos(2\vartheta) + \Delta_U \sin(2\vartheta), \\ \Delta'_U &= -\Delta_Q \sin(2\vartheta) + \Delta_U \cos(2\vartheta),\end{aligned}\quad (13)$$

when rotated by ϑ about \hat{n} . Since at each point in Fourier space, the coordinate system defined by θ and φ (or equivalently \hat{u} and \hat{v}) has a different orientation, we need to rotate by ξ about \hat{n} (see Fig. 1), in order for the contribution from each Fourier mode to Q and U to have the same orientation in the laboratory frame before being integrated over. Using the laws of sines and cosines for spherical triangles, we obtain the following relations for ξ :

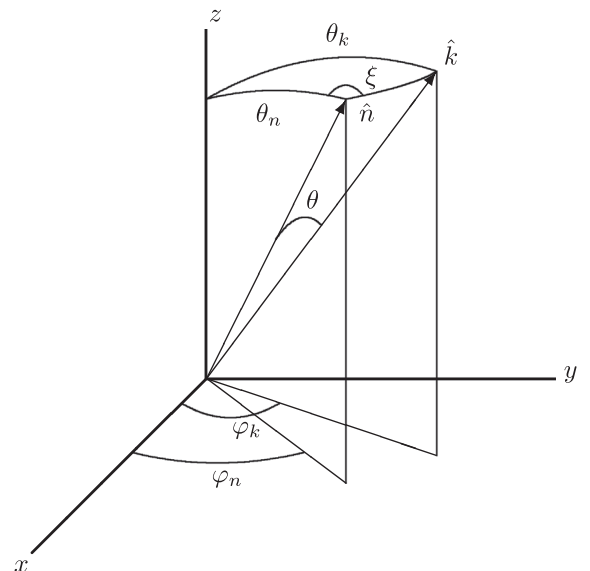

FIG. 1. Angle definitions.

$$\frac{\sin \xi}{\sin \theta_k} = \frac{\sin(\varphi_k - \varphi_n)}{\sin \theta} = \frac{\sin \varphi}{\sin \theta_n},$$

$$\cos \theta_k = \mu \cos \theta_n + \sin \theta \sin \theta_n \cos \xi, \quad (14)$$

where θ_k and φ_k are the polar and azimuthal angles that define \hat{k} in spherical coordinates in the laboratory frame and, similarly, θ_n and φ_n are the polar and azimuthal angles that define \hat{n} . This allows us to write the equation for Δ_Q as

$$\Delta_Q = \int d\eta e^{-ik\mu(\eta_0 - \eta)} e^{-\tau} \tau \Pi_{ij} ((\hat{u}_i \hat{u}_j - \hat{v}_i \hat{v}_j) \cos 2\xi + (\hat{u}_i \hat{v}_j + \hat{v}_i \hat{u}_j) \sin 2\xi), \quad (15)$$

with the equation for Δ_U being the same except $\cos 2\xi$ is replaced by $-\sin 2\xi$ and $\sin 2\xi$ by $\cos 2\xi$. It follows from above that the angle of rotation between the bases (\hat{u}, \hat{v}) and $(\hat{\theta}, \hat{\varphi})$, the latter defined in the usual way,

$$\hat{\theta} = (\cos \theta_n \cos \varphi_n, \cos \theta_n \sin \varphi_n, -\sin \theta_n),$$

$$\hat{\varphi} = (-\sin \varphi_n, \cos \varphi_n, 0), \quad (16)$$

is ξ . This can also be verified by taking the dot products of the two bases and using the equations (14). Explicitly, we then have

$$\hat{u} = \hat{\theta} \cos \xi - \hat{\varphi} \sin \xi,$$

$$\hat{v} = \hat{\theta} \sin \xi + \hat{\varphi} \cos \xi, \quad (17)$$

from which we obtain

$$\hat{\theta}_i \hat{\theta}_j - \hat{\varphi}_i \hat{\varphi}_j = (\hat{u}_i \hat{u}_j - \hat{v}_i \hat{v}_j) \cos 2\xi + (\hat{u}_i \hat{v}_j + \hat{v}_i \hat{u}_j) \sin 2\xi,$$

$$\hat{\theta}_i \hat{\varphi}_j + \hat{\varphi}_i \hat{\theta}_j = -(\hat{u}_i \hat{u}_j - \hat{v}_i \hat{v}_j) \sin 2\xi + (\hat{u}_i \hat{v}_j + \hat{v}_i \hat{u}_j) \cos 2\xi, \quad (18)$$

which in turn enables us to Fourier transform the equations for Δ_Q and Δ_U :

$$\Delta_Q(\hat{n}) = \int d\eta e^{-\tau} \tau \Pi_{ij} (\hat{\theta}_i \hat{\theta}_j - \hat{\varphi}_i \hat{\varphi}_j),$$

$$\Delta_U(\hat{n}) = \int d\eta e^{-\tau} \tau \Pi_{ij} (\hat{\theta}_i \hat{\varphi}_j + \hat{\varphi}_i \hat{\theta}_j). \quad (19)$$

The above equations for the polarization along the line of sight (19), together with the modified temperature equation (12) are the desired results. Of course, the equations do not contain new physics, because, as mentioned earlier, it is included in Einstein-Boltzmann solvers that directly compute CMB power spectra such as CMBFAST [1] but, unlike harmonic space formulas, their form gives us a clear view of the phenomena producing CMB temperature anisotropies and polarization along the line of sight. Given a 3D Einstein-Boltzmann solver to evolve the cosmological perturbations such as the Landriau-Shellard code [4], they also allow us to compute CMB maps from the recombination epoch onwards, by ray tracing through the simulation box. In particular, they can be used in the case where they are seeded by cosmic strings [6,10], which allows one to search for stringlike features in the CMB maps.

IV. CONCLUSION

I have derived real space formulas for the CMB temperature anisotropies and polarization that contain all the relevant physics to first order in the cosmological perturbations. These are equivalent to the harmonic space formulas found in the literature and furthermore, allow the direct computation of maps of the CMB polarization and temperature from the recombination epoch onwards when the perturbations are evolved in three-dimensional simulations. This allows one to study localized features in the maps that are not identifiable in the power spectra.

ACKNOWLEDGMENTS

I would like to thank Eiichiro Komatsu for suggesting this topic of investigation many years ago and showing me the way by deriving the scalar part of Eq. (12).

-
- [1] U. Seljak and M. Zaldarriaga, *Astrophys. J.* **469**, 437 (1996).
 [2] R. K. Sachs and A. M. Wolfe, *Astrophys. J.* **147**, 73 (1967).
 [3] U. L. Pen, D. N. Spergel, and N. Turok, *Phys. Rev. D* **49**, 692 (1994).
 [4] M. Landriau and E. P. S. Shellard, *Phys. Rev. D* **67**, 103512 (2003).
 [5] J. R. Bond and G. Efstathiou, *Mon. Not. R. Astron. Soc.* **226**, 655 (1987).
 [6] M. Landriau and E. P. S. Shellard, *Phys. Rev. D* **83**, 043516 (2011).

- [7] A. Melchiorri and N. Vittorio, in *The Cosmic Microwave Background*, edited by C. H. Lineweaver, J. G. Bartlett, A. Blanchard, M. Signore and J. Silk, NATO ASI Series C Vol. 502 (Kluwer Academic Publishers, Dordrecht, 1997), pp. 419–440.
 [8] S. Chandrasekhar, *Radiative Transfer* (Clarendon Press, Oxford, 1950).
 [9] Note that the prefactors for Π^S and the Π^V s suggest that they should have been defined differently in [4], but for consistency, the same definition was kept.
 [10] M. Landriau and E. P. S. Shellard, Cosmic string induced maps of CMB polarization (to be published).