

Top quark forward-backward asymmetry from $SU(N_c)$ color

Robert Foot*

ARC Centre of Excellence for Particle Physics at the Terascale, School of Physics,
The University of Melbourne, Victoria 3010, Australia
(Received 16 March 2011; published 3 June 2011)

We argue that the $t\bar{t}$ production asymmetry observed at the Tevatron might be simply explained if the standard $SU(3)_c$ QCD theory is extended to $SU(N_c)$ which is spontaneously broken at a scale just above the weak scale. The extended gauge interactions amplify the radiative QCD contribution to the asymmetry and can potentially explain the observations if $N_c \geq 5$. This explanation suggests a relatively low $SU(N_c)$ symmetry breaking scale ≈ 0.5 –1 TeV. We check that such a low $SU(N_c)$ symmetry breaking scale is consistent with current collider data. Importantly this scenario predicts an abundance of striking phenomena which will be probed at the LHC. The $SU(N_c)$ model also illustrates the idea that a beyond standard model contribution to the $t\bar{t}$ asymmetry might arise primarily via radiative corrections rather than at tree level.

DOI: 10.1103/PhysRevD.83.114013

PACS numbers: 14.65.Ha

I. INTRODUCTION

The CDF collaboration has observed [1] an unexpectedly large forward-backward $t\bar{t}$ production asymmetry at the Tevatron. With an integrated luminosity of 5.3 fb^{-1} , the asymmetry is found to vary strongly with the invariant mass of the $t\bar{t}$ pair ($M_{t\bar{t}}$). At the parton level, the required $t\bar{t}$ asymmetry in the $t\bar{t}$ rest frame is observed to be

$$\begin{aligned} A_{t\bar{t}} &= 0.475 \pm 0.114 \quad \text{for } M_{t\bar{t}} > 450 \text{ GeV} \\ A_{t\bar{t}} &= -0.116 \pm 0.153 \quad \text{for } M_{t\bar{t}} < 450 \text{ GeV}. \end{aligned} \quad (1)$$

These asymmetries can be compared with the next-to-leading order QCD prediction of [1] (see also [2]):

$$\begin{aligned} A_{t\bar{t}} &= 0.088 \pm 0.013 \quad \text{for } M_{t\bar{t}} > 450 \text{ GeV} \\ A_{t\bar{t}} &= 0.040 \pm 0.006 \quad \text{for } M_{t\bar{t}} < 450 \text{ GeV}. \end{aligned} \quad (2)$$

The statistical significance of the excess is 3.4σ and represents exciting evidence for new physics. Possible explanations for the asymmetry include s-channel interference of an exotic color octet gauge boson or t-channel scalar/vector exchange, see e.g. Ref. [3,4] for some recent studies. All of these explanations involve an exotic tree level contribution to the $t\bar{t}$ production amplitude and generally have significant experimental constraints coming from resonance production, like-sign top quark production etc. In this paper we wish to explore the novel possibility that the asymmetry arises predominately as a radiative effect, analogous to the QCD contribution.

The leading order QCD $q\bar{q} \rightarrow t\bar{t}$ production asymmetry arises from two different reactions [5]. The first involves interference of initial state with final state gluon bremsstrahlung. The second involves interference between the tree level $q\bar{q} \rightarrow t\bar{t}$ process and its one-loop correction. The Feynman diagrams are shown in Fig. 1.

Considering first the asymmetry due to the interference between the tree level $q\bar{q} \rightarrow t\bar{t}$ process and its one-loop correction, it was found in Ref. [5] that the QCD asymmetry is obtained from the corresponding QED result via the replacement:

$$\alpha_{\text{QED}} Q_q Q_t \rightarrow \frac{d_{abc}^2}{16N_c T_F C_F} \alpha_S = \frac{5}{12} \alpha_S \quad (3)$$

where $C_F = (N_c^2 - 1)/2N_c = 4/3$ and $T_F = 1/2$. It is instructive to make the full N_c dependence explicit. Using $d_{abc}^2 = (N_c^2 - 4)(N_c^2 - 1)/N_c$, we find that the QCD asymmetry is obtained from the corresponding QED result via the replacement:

$$\alpha_{\text{QED}} Q_q Q_t \rightarrow \frac{N_c^2 - 4}{4N_c} \alpha_S. \quad (4)$$

The asymmetry due to the interference of an initial state with final state gluon bremsstrahlung is also proportional to d_{abc}^2 and has the same N_c dependence. That is, to leading order we have that

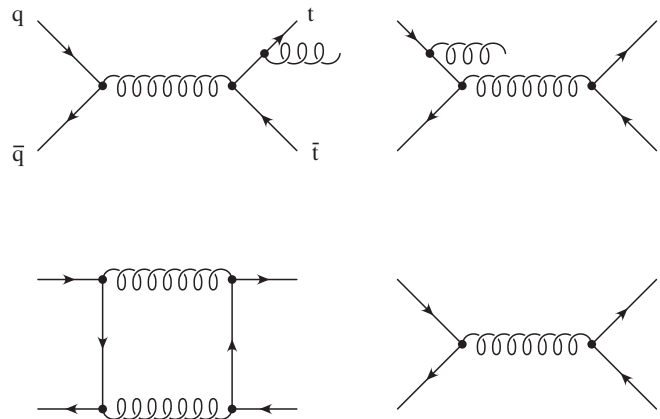

FIG. 1. Interfering $q\bar{q} \rightarrow t\bar{t}j$ (above) and $q\bar{q} \rightarrow t\bar{t}$ (below) amplitudes.

*rfoot@unimelb.edu.au

$$A_{t\bar{t}} \propto \frac{N_c^2 - 4}{4N_c}. \quad (5)$$

Thus we arrive at the interesting result that the asymmetry increases rapidly with increasing N_c . This observation suggests that gauge models where $SU(3)_c$ is incorporated into a larger $SU(N_c)$ gauge symmetry which is broken near the weak scale might provide a suitable candidate for the new physics needed to explain the $t\bar{t}$ asymmetry. Furthermore this illustrates the novel idea that a new physics contribution to the $t\bar{t}$ asymmetry could arise primarily via radiative corrections rather than at tree level.

II. THE $SU(5)_c$ MODEL—AND GENERALIZATION TO $SU(N_c)$

An example of such an extended gauge model for the strong interactions is given by the anomaly-free $SU(5)_c \otimes SU(2)_L \otimes U(1)_{Y'}$ gauge model proposed some time ago by Hernandez and I [6], and further studied in Ref. [7–11]. In the $SU(5)_c$ model, the quarks and leptons of each generation transform under the gauge symmetry $SU(5)_c \otimes SU(2)_L \otimes U(1)_{Y'}$ in the anomaly-free representation:

$$f_L = \begin{pmatrix} \nu \\ e \end{pmatrix}_L \sim (1, 2, -1), \quad e_R \sim (1, 1, -2), \quad (6)$$

$$Q_L = \begin{pmatrix} u \\ d \end{pmatrix}_L \sim (5, 2, 1/5), \quad (7)$$

$$u_R \sim (5, 1, 6/5), \quad d_R \sim (5, 1, -4/5).$$

Gauge symmetry breaking is accomplished via the vacuum expectation values (VEVs) of a scalar $\chi \sim (\bar{10}, 1, 2/5)$ along with the usual Higgs scalar, $\phi \sim (1, 2, +1)$:

$$\langle \chi \rangle = \begin{pmatrix} 0 & 0 & 0 & 0 & 0 \\ 0 & 0 & 0 & 0 & 0 \\ 0 & 0 & 0 & 0 & 0 \\ 0 & 0 & 0 & 0 & w \\ 0 & 0 & 0 & -w & 0 \end{pmatrix}, \quad \langle \phi \rangle = \begin{pmatrix} 0 \\ u \end{pmatrix}. \quad (8)$$

The $SU(5)_c \otimes U(1)_{Y'}$ gauge symmetry is assumed to be spontaneously broken by the VEV of χ at a scale just above the weak scale, which along with the usual Higgs doublet ϕ leads to the symmetry breaking pattern:

$$\begin{aligned} & SU(5)_c \otimes SU(2)_L \otimes SU(2)_{Y'} \\ & \quad \downarrow \langle \chi \rangle \\ & SU(3)_c \otimes SU(2)' \otimes SU(2)_L \otimes U(1)_Y \quad (9) \\ & \quad \downarrow \langle \phi \rangle \\ & SU(3)_c \otimes SU(2)' \otimes U(1)_Q \end{aligned}$$

where $Y = Y' + \frac{T_5}{\sqrt{15}}$ is the linear combination of Y' and T_5 which annihilates $\langle \chi \rangle$ (i.e. $Y\langle \chi \rangle = 0$). (T_5 is the

diagonal generator of $SU(5)_c$ orthogonal to those of the $SU(3) \otimes SU(2)'$ subgroup, i.e. $T_5 = \sqrt{\frac{12}{5}} \text{diag}(1/3, 1/3, 1/3, -1/2, -1/2)$).

The extra color degree's of freedom have been called “quirks” and studied in some detail by Carlson *et al* [11]. These fermions have electric charge $\pm 1/2$ and are confined into integer charged bound states by the unbroken and asymptotically-free $SU(2)'$ gauge interaction ($\Lambda_{SU(2)'} \sim 0.5$ GeV). These exotic fermions are given mass by coupling to χ via the Yukawa Lagrangian:

$$\mathcal{L} = \lambda_L \bar{Q}_L \chi (Q_L)^c + \lambda_R \bar{u}_R \chi (d_R)^c. \quad (10)$$

Note that the generation index has been suppressed. Besides these electroweak invariant masses, there are $SU(5)_c$ invariant mass terms coming from the usual coupling terms with the standard Higgs doublet, ϕ .

In addition to the standard model gauge bosons the model contains a Z'_μ and charged (with electric charge $\pm 1/6$) W'_μ gauge bosons (from $SU(5) \otimes U(1)_{Y'}/SU(3) \times U(1)_Y$ coset). The latter transform as a $(3, 2, 1/6)$ and $(\bar{3}, 2, -1/6)$ under the unbroken $SU(3)_c \otimes SU(2)' \otimes U(1)_Q$ gauge group. These gauge bosons gain masses of [6]

$$M_{Z'}^2 \simeq \frac{12}{5} g_s^2 w^2, \quad \frac{M_{W'}^2}{M_{Z'}^2} \simeq \frac{5}{12}, \quad (11)$$

where w is the VEV of χ . The mass eigenstate neutral γ , Z , Z' gauge bosons couple to fermions as follows:

$$\mathcal{L} = -e A_\mu J_{em}^\mu - \frac{2e}{\sin 2\theta_w} Z_\mu J_N^\mu - g_s Z'_\mu J_{N'}^\mu \quad (12)$$

where the currents are given by

$$J_{em}^\mu = \bar{\psi} Q \gamma^\mu \psi, \quad J_N^\mu = \bar{\psi} N \gamma^\mu \psi, \quad J_{N'}^\mu = \bar{\psi} N' \gamma^\mu \psi. \quad (13)$$

The summation of fermion fields is implied and the generators Q , N and N' are given by

$$\begin{aligned} Q &= I_3 + \frac{Y'}{2} + \frac{T_5}{2\sqrt{15}}, & N &= (I_3 - \sin^2\theta_w Q) + \Delta, \\ N' &= \frac{T_5}{2} + \Delta' \end{aligned} \quad (14)$$

where Δ and Δ' are small corrections given by

$$\Delta \simeq \frac{-e^2 u^2 \sqrt{5/3} T_5}{48 g_s^2 w^2 \cos^2 \theta_w}, \quad \Delta' \simeq \frac{e^2 Y'}{2\sqrt{15} g_s^2 \cos^2 \theta_w}. \quad (15)$$

Note that we have defined θ_w by $\cos^2 \theta_w \equiv m_W^2/m_{Z'}^2$.

Importantly the scale of $SU(5)_c \otimes U(1)_{Y'}$ symmetry breaking can be very low [6–11]. The Z' is very weakly constrained because it couples mainly to hadrons and its mixing with the Z is naturally very small. For example, in Ref. [7] only the very modest limit of $m_{Z'} \gtrsim 100$ GeV was obtained from neutral current phenomenology. A more

stringent limit of $M_{Z'} > 280$ GeV was obtained from UA2 dijet data in Ref. [9]. In Sec. IV we will confront this model with more recent dijet data from the Tevatron where we show that a low $SU(5)_c$ symmetry breaking scale is still experimentally allowed, although not without some tension. The quirk mass is also very weakly constrained. A mass limit on the quirks can be obtained from measurements of the Z boson width, which limits the mass of the quirks to be greater than 43 GeV. In addition, flavor changing neutral current processes, such as the radiative contribution to $K^0 - \bar{K}^0$ mass mixing constrain the quirk masses to be roughly degenerate or the corresponding CKM-type matrix to be almost diagonal [11].

The case of larger (odd) N_c is a straightforward generalization to the $SU(5)_c$ case, but requires a more complex Higgs sector to achieve the required symmetry breaking.¹ To break the symmetry in a phenomenologically consistent way in $SU(N_c)$ with $N_c > 5$ will require several scalar multiplets. For example, an $SU(7)_c \otimes SU(2)_L \otimes U(1)_{Y'}$ model can be constructed by placing the fermions into the anomaly-free representation:

$$f_L = \begin{pmatrix} \nu \\ e \end{pmatrix}_L \sim (1, 2, -1), \quad e_R \sim (1, 1, -2), \quad (16)$$

$$Q_L = \begin{pmatrix} u \\ d \end{pmatrix}_L \sim (7, 2, 1/7), \quad u_R \sim (7, 1, 8/7), \\ d_R \sim (5, 1, -6/7). \quad (17)$$

The $SU(7)_c \otimes U(1)_{Y'}$ can be spontaneously broken by the VEVs of two scalars, $\chi_1, \chi_2 \sim (\bar{21}, 1, 2/7)$ at a scale just above the weak scale. These VEVs are given by

$$\langle \chi_1 \rangle = \begin{pmatrix} 0 & 0 & 0 & 0 & 0 & 0 & 0 \\ 0 & 0 & 0 & 0 & 0 & 0 & 0 \\ 0 & 0 & 0 & 0 & 0 & 0 & 0 \\ 0 & 0 & 0 & 0 & 0 & 0 & 0 \\ 0 & 0 & 0 & 0 & 0 & 0 & 0 \\ 0 & 0 & 0 & 0 & 0 & 0 & w_1 \\ 0 & 0 & 0 & 0 & 0 & -w_1 & 0 \end{pmatrix}, \\ \langle \chi_2 \rangle = \begin{pmatrix} 0 & 0 & 0 & 0 & 0 & 0 & 0 \\ 0 & 0 & 0 & 0 & 0 & 0 & 0 \\ 0 & 0 & 0 & 0 & 0 & 0 & 0 \\ 0 & 0 & 0 & 0 & w_2 & 0 & 0 \\ 0 & 0 & 0 & -w_2 & 0 & 0 & 0 \\ 0 & 0 & 0 & 0 & 0 & 0 & 0 \\ 0 & 0 & 0 & 0 & 0 & 0 & 0 \end{pmatrix}. \quad (18)$$

¹The case of even N_c is possible, although the simplest such theories run into phenomenological problems [12].

These VEVs will give the exotic quirk degree's of freedom electroweak invariant masses, analogously to the $SU(5)_c$ case (Eq. (10)). These VEVs along with $\langle \phi \rangle$ lead to the symmetry breaking pattern

$$SU(7)_c \otimes SU(2)_L \otimes SU(2)_{Y'} \\ \downarrow \langle \chi_1 \rangle, \langle \chi_2 \rangle \\ SU(3)_c \otimes SU(2)' \otimes SU(2)' \otimes SU(2)_L \otimes U(1)_Y \quad (19) \\ \downarrow \langle \phi \rangle \\ SU(3)_c \otimes SU(2)' \otimes SU(2)' \otimes U(1)_Q$$

where $Y = Y' + \frac{2}{\sqrt{42}} T_7$. Here T_7 denotes the $SU(7)$ diagonal generator:

$$T_7 = \sqrt{\frac{24}{7}} \text{diag}(1/3, 1/3, 1/3, -1/4, -1/4, -1/4, -1/4). \quad (20)$$

The $SU(7)_c$ model will contain two Z' gauge bosons, Z'_1, Z'_2 . These gauge bosons couple to the generators

$$Z'_1: \quad \cos\theta' \frac{T_7}{2} + \sin\theta' \frac{T_x}{2} \\ Z'_2: \quad -\sin\theta' \frac{T_7}{2} + \cos\theta' \frac{T_x}{2} \quad (21)$$

where T_7 is defined above and $T_x = \sqrt{2} \text{diag}(0, 0, 0, -1/2, -1/2, 1/2, 1/2)$, and θ' is obtained by diagonalizing the Z' gauge boson mass matrix:

$$\begin{pmatrix} \frac{6}{7} g_s^2 (w_1^2 + w_2^2) & \sqrt{\frac{12}{7}} g_s^2 (w_1^2 - w_2^2) \\ \sqrt{\frac{12}{7}} g_s^2 (w_1^2 - w_2^2) & 2 g_s^2 (w_1^2 + w_2^2) \end{pmatrix}.$$

That is, $\tan 2\theta' = \frac{\sqrt{21}}{2} \left[\frac{w_2^2 - w_1^2}{w_2^2 + w_1^2} \right]$. For $SU(7)_c$ and the case of larger N_c , other symmetry breaking patterns are possible depending on the scalar content of the theory.

III. TOP QUARK FORWARD-BACKWARD ASYMMETRY IN $SU(N_c)$ COLOR THEORIES

The QCD contributions to the $t\bar{t}$ forward-backward asymmetry feature infrared (IR) divergences. The contribution due to gluon bremsstrahlung can be separated into hard and soft gluon emission, and the IR divergence from the latter cancelling the IR divergence from the box diagram contribution to the asymmetry [2,5]. Calculations show that the hard gluon bremsstrahlung contribution to $A_{t\bar{t}}$ is negative, while the soft gluon plus virtual part is positive [2,5]. It turns out that the soft gluon bremsstrahlung + virtual box diagram part is about twice the magnitude of the hard bremsstrahlung part, so that the predicted QCD asymmetry is positive.

In the extended $SU(N_c)$ color gauge models, the $t\bar{t}$ asymmetry should be approximately the same as that predicted in the standard model at energies below the scale of $SU(N_c)$ symmetry breaking, which we take here for illustration as a single scale, m . The radiative processes involving exotic W' , Z' gauge bosons and quirks are suppressed by powers of $\sqrt{\hat{s}}/m$. Thus, things are clear in the $m \gg \sqrt{\hat{s}}$ limit—the standard model calculation of the $t\bar{t}$ asymmetry results. Let us now examine the $m \ll \sqrt{\hat{s}}$ limit. In this limit we expect the $SU(N_c)$ symmetry to be a good approximation and provided that T quirks (we denote the quirk partner of the corresponding quark with an uppercase letter) decay into t -quarks,² then the $t\bar{t}$ asymmetry should follow from Eq. (5). If the region $M_{t\bar{t}} > 450$ GeV is sufficiently high that the $SU(N_c)$ limit becomes useful, then we can predict from Eq. (5) a $t\bar{t}$ forward-backward asymmetry of

$$\begin{aligned} A_{t\bar{t}} &\approx 0.22 & \text{for } N_c = 5, \\ A_{t\bar{t}} &\approx 0.34 & \text{for } N_c = 7, \\ A_{t\bar{t}} &\approx 0.45 & \text{for } N_c = 9, \\ A_{t\bar{t}} &\approx 0.56 & \text{for } N_c = 11 \text{ etc.} \end{aligned} \quad (22)$$

In the realistic case we might have $\sqrt{\hat{s}} \sim m$ and that T quirks might not decay predominately into t -quarks, in any case the bremsstrahlung contribution can potentially be kinematically suppressed. In this case, the exotic contribution to the $t\bar{t}$ asymmetry should arise predominately from the interference of the tree level $q\bar{q} \rightarrow t\bar{t}$ amplitude with the virtual box diagram amplitude. It seems that the size of this contribution can be even larger than that suggested by the $SU(N_c)$ symmetry estimate, Eq. (22), since that estimate includes the hard bremsstrahlung contribution, which is negative in sign. It is also possible that the exotic box diagram contributions are smaller than the $SU(N_c)$ estimate, Eq. (22) or even that it has the wrong sign (although it is unlikely that it has the wrong sign for all ranges of parameters). For completeness one also needs to calculate the box diagram contribution with gauge bosons replaced by the χ scalar/Goldstone bosons (in 't Hooft-Feynman gauge). The latter could dominate if the quirks are heavier than the gauge bosons. In this paper we will be content with pointing out the novel possibility that the top quark forward-backward asymmetry might be radiatively induced with $SU(N_c)$ models as a promising example. Obviously if the CDF anomaly is confirmed by future data then more detailed calculations will be necessary to pin down the $m_{\text{quirk}}/m_{Z',W'}/N_c$ parameter space allowed by the experiments.

²The part of the asymmetry due to the interference of initial and final state bremsstrahlung will contain $q\bar{q} \rightarrow tW'T$ final states (as well as $q\bar{q} \rightarrow t\bar{t}g$ final states). The T quirks can decay into top quarks: $T \rightarrow tU\bar{u}$ via a virtual W' , assuming that the U quirk is the lightest quirk.

Observe that the total top quark production cross section in $SU(N_c)$ color models is not expected to be significantly ($\leq 15\%$) modified from the standard model prediction. This is because the main effect of the new physics is to increase the radiative contribution which generates the asymmetry via interference with the QCD contribution. The proportion of T quirks produced is relatively small.

If $SU(N_c)$ color gauge theory is the origin of the $t\bar{t}$ asymmetry then the scale of new physics is likely to be low (unless N_c is very big), and we thus expect this explanation to be tested in the future at the LHC experiment. However in the meantime we need to check that the low $SU(N_c)$ symmetry breaking scale is compatible with existing data.

IV. TEVATRON LIMITS ON $SU(5)_c$ [$SU(N_c)$] SYMMETRY BREAKING SCALE

Data from the Tevatron might constrain the $SU(5)_c$ symmetry breaking scale. The most promising signature is expected to be the effects of the Z' since this particle can be produced on resonance if its mass is low [8,9]. The Z' will manifest itself primarily as a bump in the dijet invariant mass distribution. No such bump is seen, leading to strong constraints on possible Z' coupling to quarks. For example, the CDF collaboration [13] are able to exclude an axigluon with mass $260 < m < 1250$ GeV. However, it turns out that the $SU(5)_c$ Z' couples to each quark color with coupling $g_s/\sqrt{15}$. The $1/\sqrt{15}$ factor significantly suppresses the cross section c.f. axigluons. We have computed the cross section for $p\bar{p} \rightarrow Z' \rightarrow 2$ jets. This is obtained by calculating the cross section for the parton subprocess $q\bar{q} \rightarrow Z' \rightarrow q'\bar{q}'$ and then folding this in with the parton distribution functions in the usual way. We use the 2008MSTW NLO parton distribution functions in our numerical work [14]. The cross section is multiplied by the standard K factors

$$K_i = 1 + \frac{8\pi\alpha_s(q^2)}{9}, \quad K_f = 1 + \frac{\alpha_s(q^2)}{\pi} \quad (23)$$

to incorporate the QCD corrections in the initial and final states. We have also applied a rapidity cut of $|y| < 1$ for each of the two jets. Our results are shown in Fig. 2. The calculation assumes that the quirks are light, so that they contribute to the total width of the Z' but do not contribute to the dijet signal.³ Also shown in the figure is the corresponding CDF 95% C.L. upper limit [13].

As the figure shows, there is some tension between a low $SU(5)_c$ breaking scale, which disfavors the model but is not quite strong enough to conclusively exclude it. In the case of $SU(7)_c$ and larger color groups, having multiple Z' s might help evade the CDF dijet constraint by effectively smoothing out the dijet bump. The Z' can also decay leptonically via a small Y' coupling (from the Δ' part in Eqs. (14) and (15)). However the branching fraction to leptons is very small, for example, we find that

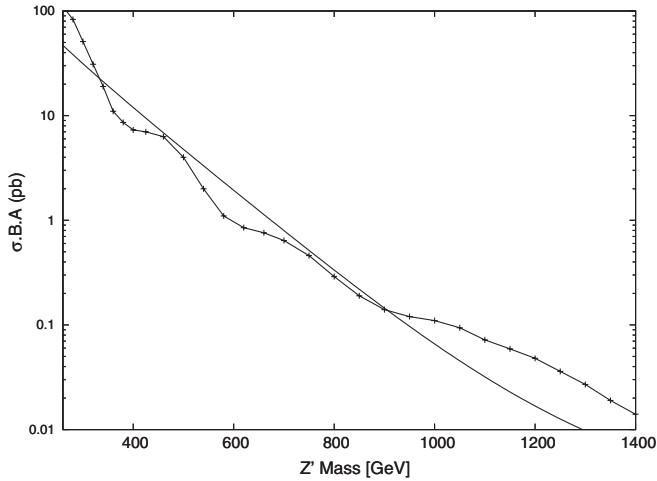

FIG. 2. The Z' particle production cross section times branching fraction into dijets times the acceptance for both jets to have $|y| < 1$. Also shown, is the corresponding CDF 95% C.L. upper limit.

$\text{Br}(Z' \rightarrow \mu\bar{\mu}) \simeq 1.4 \times 10^{-4}$. In fact this branching fraction is sufficiently small to evade Tevatron limits [15] on resonances decaying into muon pairs.

The Tevatron might potentially constrain the quirk masses. Quirk pairs can be produced via γ, Z, Z' exchange. While heavy quirks can decay into lighter ones, the lightest pair of quirks are expected to hadronize (assuming the lightest quirk is lighter than the W' or $SU(2)'$ colored scalar components). As discussed in some detail in Ref. [11], this quirk pair can be viewed as a highly excited quarkonium state. Deexcitation occurs via numerous emission of $SU(2)'$ glueballs, dubbed “hueballs” in Ref. [11]. Note that the hueball emission will lead to substantial missing energy but only small missing transverse momentum. The quarkonium will end up in the ground state where it will decay via virtual γ, Z into standard model particles.

The quirk production cross section times branching ratio into muons at the Tevatron has been calculated in Ref. [11]. They obtain a cross section times branching ratio into muon pairs of about 10 fb for a quirk mass of 100 GeV for left-handed quirks, and much weaker limits for right-handed quirks. This is well below current limits obtained by the CDF collaboration [15]. Thus, we conclude that a low $SU(N_c)$ symmetry breaking scale of a few hundred GeV is phenomenologically viable, and consequently the $SU(N_c)$ explanation of the top quark forward-backward asymmetry is possible.

Observe that the $SU(N_c)$ explanation of the $t\bar{t}$ forward-backward asymmetry would imply a similarly sized

³Quirk pairs can annihilate into jets, but at a lower invariant mass, where the dijet constraints are much weaker.

asymmetry for $b\bar{b}$ quark production. It has been argued in Ref. [4,16] that such an asymmetry, although challenging, could likely be measured at the Tevatron. If this is the case then this will further test the $SU(N_c)$ model.

The CDF collaboration has also recently found an anomalously high number of boosted jets ($p_T > 400$ GeV for the leading jet) with invariant mass near the top quark mass [17]. The anomaly could be due to an underestimation of background but might also be a signal for new physics. Such a signal can be explicable in $SU(N_c)$ models. For instance, if $m_{Z'} \sim 0.8\text{--}1$ TeV, then $Z' \rightarrow t\bar{t}$ decays will generally lead to a boosted top. Furthermore, from Fig. 2 we see that the cross section for hadronically decaying Z' is of order 0.1 pb, which implies a cross section to hadronically decaying top pairs of about 10 fb. This value is roughly consistent with the value necessary to explain the CDF data if it is due to new physics [17,18]. The CDF collaboration did not observe any anomaly in the boosted jet plus missing energy channel (corresponding to one of the top quarks decaying semileptonically). However it has been argued in Ref. [19] that the semileptonic channel is less sensitive than the fully hadronic decay channel.

The LHC should be able to probe the $SU(N_c)$ explanation for the $t\bar{t}$ asymmetry. The quirks, W', Z' gauge bosons and also the exotic colored χ scalar can be produced at the LHC, leading to dijet signals. We expect, however, that at least several fb^{-1} of data might need to be accumulated before this explanation of the $t\bar{t}$ asymmetry can be put to the test. We leave detailed predictions for the LHC for future work.

V. CONCLUSION

In conclusion, we have pointed out that the $t\bar{t}$ forward-backward asymmetry observed at the Tevatron might be simply explained if the standard $SU(3)_c$ QCD theory is extended to $SU(N_c)$ which is spontaneously broken at a scale just above the weak scale. The extended gauge interactions amplify the QCD radiative contribution to the asymmetry and can potentially explain the observations if $N_c \geq 5$. This explanation suggests a relatively low $SU(N_c)$ symmetry breaking scale $\simeq 0.5\text{--}1$ TeV, and we have checked that this is compatible with recent collider data. Importantly this scenario predicts an abundance of new physics just above the weak scale, which will be probed in the future at the LHC.

ACKNOWLEDGMENTS

R. F. thanks Archil Kobakhidze for useful conversations and G. Rodrigo for some helpful correspondence. This work was supported in part by the Australian Research Council.

- [1] T. Aaltonen *et al.* (CDF collaboration), [arXiv:1101.0034](#).
- [2] L.G. Almeida, G.F. Sterman, and W. Vogelsang, *Phys. Rev. D* **78**, 014008 (2008); O. Antuano, J.H. Kuhn, and G.V. Rodrigo, *Phys. Rev. D* **77**, 014003 (2008); M.T. Bowen, S.D. Ellis, and D. Rainwater, *Phys. Rev. D* **73**, 014008 (2006); For earlier work see also R. W. Brown, D. Sadhev and K.O. Mikaelian, *Phys. Rev. Lett.* **43**, 1069 (1979); F. Halzen, P. Hoyer, and C.S. Kim, *Phys. Lett. B* **195**, 74 (1987).
- [3] P. Ferrario and G. Rodrigo, *Phys. Rev. D* **78**, 094018 (2008); S. Jung *et al.*, *Phys. Rev. D* **81**, 015004 (2010); K. Cheung, W-Y. Keung, and T-C. Yuan, *Phys. Lett. B* **682**, 287 (2009); A. Arhrib, R. Benbrik, and C-H. Chen, *Phys. Rev. D* **82**, 030434 (2010); P.H. Frampton, J. Shu, and K. Wang, *Phys. Lett. B* **683**, 294 (2010); D-W. Jung *et al.*, *Phys. Lett. B* **691**, 238 (2010); J. Cao *et al.*, *Phys. Rev. D* **81**, 014016 (2010); I. Dorsnet *et al.*, *Phys. Rev. D* **81**, 05509 (2010); J. Shu, T.M.P. Tait, and K. Wang, *Phys. Rev. D* **81**, 034012 (2010); V. Barger, W-Y. Kueng, and C-T. Yu, *Phys. Rev. D* **81**, 113009 (2010); *Phys. Lett. B* **698**, 243 (2011); Q-H. Cao *et al.*, *Phys. Rev. D* **81**, 114004 (2010); B. Xiao, Y. Wang, and S. Zhu, *Phys. Rev. D* **82**, 034026 (2010); C-H. Chen, G. Cvetič, and C.S. Kim, *Phys. Lett. B* **694**, 393 (2011); K. Cheung and T-C. Yuan, *Phys. Rev. D* **83**, 074006 (2011); E.L. Berger *et al.*, *Phys. Rev. Lett.* **106**, 201801 (2011); J. Cao *et al.*, [arXiv:1101.4456](#); C. Delaunay *et al.*, [arXiv:1101.2902](#); B. Grinstein, A.L. Kagan, M. Trott, and J. Zupan, [arXiv:1102.3374](#); K.M. Patel and P. Sharma, *J. High Energy Phys.* 1104 (2011) 085; B. Bhattacharjee, S.S. Biswal, and D. Ghosh, *Phys. Rev. D* **83**, 091501 (2011); E. Ramirez Barreto, Y.A. Coutinho, and J. Sa Borges, *Phys. Rev. D* **83**, 054006 (2011); A.R. Zerwekh, [arXiv:1103.0956](#).
- [4] Y. Bai, J.L. Hewett, J. Kaplan, and T.G. Rizzo, *J. High Energy Phys.* 1103 (2011) 003.
- [5] J.H. Kuhn and G. Rodrigo, *Phys. Rev. D* **59**, 054017 (1999).
- [6] R. Foot and O.F. Hernandez, *Phys. Rev. D* **41**, 2283 (1990); **42**, 948(E) (1990).
- [7] S.L. Glashow and U. Sarid, *Phys. Lett. B* **246**, 188 (1990).
- [8] R. Foot, O.F. Hernandez, and T.G. Rizzo, *Phys. Lett. B* **246**, 183 (1990).
- [9] R. Foot, O.F. Hernandez, and T.G. Rizzo, *Phys. Lett. B* **261**, 153 (1991).
- [10] O. Hernandez, *Phys. Rev. D* **44**, 1997 (1991).
- [11] E.D. Carlson, L.J. Hall, U. Sarid, and J.W. Burton, *Phys. Rev. D* **44**, 1555 (1991).
- [12] R. Foot and O.F. Hernandez, *Mod. Phys. Lett. A* **7**, 1315 (1992).
- [13] T. Aaltonen *et al.* (CDF Collaboration), *Phys. Rev. D* **79**, 112002 (2009).
- [14] A.D. Martin, W.J. Stirling, R.S. Thorne, and G. Watt, *Eur. Phys. J. C* **63**, 189 (2009).
- [15] T. Aaltonen *et al.* (CDF Collaboration), *Phys. Rev. Lett.* **106**, 121801 (2011).
- [16] M.J. Strassler, [arXiv:1102.0736](#).
- [17] CDF Collaboration, CDF Report No. 10234.
- [18] K. Blum *et al.*, [arXiv:1102.3133](#).
- [19] Y. Eshel, O. Gedalia, G. Perez, and Y. Soreq, [arXiv:1101.2898](#).