

**Probing the center-vortex area law in  $d = 3$ : The role of inert vortices**

John M. Cornwall\*

*Department of Physics and Astronomy, University of California, Los Angeles, California 90095, USA*  
(Received 20 January 2006; revised manuscript received 13 February 2006; published 6 March 2006)

In center-vortex theory, beyond the simplest picture of confinement several conceptual problems arise that are the subject of this paper. Recall that confinement arises through configuration averaging of phase factors associated with the gauge center group, raised to powers depending on the total Gauss link number of a vortex ensemble with a given Wilson loop. The simplest approach to confinement counts this link number by counting the number of vortices, considered in  $d = 3$  as infinitely long closed self-avoiding random walks of fixed step length, piercing any surface spanning the Wilson loop. Problems arise because a given vortex may pierce a given spanning surface several times without being linked or without contributing a nontrivial phase factor, or it may contribute a nontrivial phase factor appropriate to a smaller number of pierce points. We estimate the dilution factor  $\alpha$ , due to these inert or partially inert vortices, that reduces the ratio of fundamental string tension  $K_F$  to the areal density  $\rho$  of vortices from the ratio given by elementary approaches and find  $\alpha = 0.6 \pm 0.1$ . Then we show how inert vortices resolve the problem that the link number of a given vortex-Wilson-loop configuration is the same for any spanning surface of whatever area, yet a unique area (of a minimal surface) appears in the area law. Third, we discuss semiquantitatively a configuration of two distinct Wilson loops separated by a variable distance, and show how inert vortices govern the transition between two possible forms of the area law (one at small loop separation, the other at large), and point out the different behaviors in  $SU(2)$  and higher groups, notably  $SU(3)$ . The result is a finite-range van der Waals force between the two loops. Finally, in a problem related to the double-loop problem, we argue that the analogs of inert vortices do not affect the fact that, in the  $SU(3)$  baryonic area law, the mesonic string tension appears.

DOI: [10.1103/PhysRevD.73.065004](https://doi.org/10.1103/PhysRevD.73.065004)

PACS numbers: 11.15.-q, 11.15.Tk, 12.38.-t

**I. INTRODUCTION**

To some extent, our understanding of area laws in confining gauge theories is based on intuition and plausibility. Certainly, there can be no doubt that, in the fundamental representation of  $SU(N)$ , the expectation value  $\langle W \rangle$  of the trace of a simple flat Wilson loop  $\Gamma$  involves the area  $A$  of the flat surface spanning it and not the area of any other spanning surface:

$$W(\Gamma) \equiv \frac{1}{N} \text{Tr}_F \exp \left[ \oint_{\Gamma} dz_{\mu} A^{\mu}(z) \right]; \quad (1)$$

$$\langle W \rangle = \exp[-K_F A].$$

(Here  $K_F$  is the fundamental string tension, and we use imaginary anti-Hermitian gauge potentials, incorporating the gauge coupling  $g$  in them.) But, at least in the center-vortex picture of confinement, it is not always easy to see how some of these plausible results follow from the basically simple mechanism of confinement, based on linkages of vortices with Wilson loops. In this paper we discuss several confinement puzzles, all of them connected by the theme of inert vortices. By this we mean vortices that do not link to Wilson loops in the usual way, but occupy space that could have been occupied by truly linked vortices. For brevity we also use this term to refer to partially inert vortices that are linked, but with a smaller link number than would naively be expected.

We seek the effects of inert vortices only for large Wilson loops, those whose length scales are all large compared to the fundamental gauge-theory length  $\lambda$ . As the loop scales approach  $\lambda$  the effects of inert vortices either disappear or are substantially modified.

In the center-vortex picture, the area law arises through group-center phase factors raised to powers depending on the Gauss link number of the vortex condensate with the Wilson loop. This link number can be calculated from the intersections of a vortex with any surface spanning the Wilson loop. (When we wish to be specific that the surface in question is the one that appears in the area law, we call it the Wilson surface; for a flat loop, this is the obvious flat spanning surface.) To characterize the condensate we will stick for simplicity to  $d = 3$ , although there is no real qualitative difference between three and four dimensions. In  $d = 3$ , vortices are closed stringlike tubes of chromomagnetic flux, a finite fraction of which have infinite length, and in  $d = 4$  they are closed 2-surfaces, whose description raises complications. The existence of a vortex condensate is signaled (in both  $d = 3$  and  $d = 4$ ) by an areal density  $\rho$  of vortex pierce points through any large flat surface. In  $d = 3$  we model the vortices as closed self-avoiding infinite-length random walks on a cubical lattice of lattice length  $\lambda$ . This model is similar in spirit, if not in implementation, to the  $d = 4$  models for  $SU(2)$  and  $SU(3)$  center vortices given by others [1], for use in lattice computations. However, our random-walk lattice spacing  $\lambda$  is not the same as the lattice spacing of the models of [1],

\*Electronic address: [Cornwall@physics.ucla.edu](mailto:Cornwall@physics.ucla.edu)

which is not fine enough to resolve the nearby reentrant piercings that are the subject of Sec. II. Our random-walk lattice is also similar in spirit to the commonly used lattice picture of center vortices as infinitesimally thick objects, called P-vortices [2], that live on a lattice dual to the lattice where Wilson loops live. For P-vortices one interprets  $\lambda$  as essentially the lattice spacing, while for us (see below)  $\lambda$  is a physical quantity, like the areal density  $\rho$  itself. Because we necessarily make approximations when we attempt to describe the vortex condensate analytically, it is not elementary to say precisely what the distance  $\lambda$  is. Roughly, it is the avoidance distance: The distance scale on which a vortex must avoid a gross incursion on space occupied by another portion of itself or of another vortex. This is not to say that vortices cannot overlap to some extent, but overlap carries an action penalty that, on the average, is changing exponentially with the distance between the centers of the vortices. We will see that, in the dilute gas approximation (DGA) of low density,  $\lambda$  drops out of the formula for the string tension, but this is not so beyond the DGA.

The question of overlap brings up the closely related question of reconnection ambiguity. Suppose that the gauge group is  $SU(2)$  and that two apparently distinct vortices each pierce a horizontal Wilson surface once, and above this surface they completely overlap at an X-shaped intersection. Because the orientation of the magnetic flux in an  $SU(2)$  vortex is irrelevant for confinement via linkages, we can consider the vortices to be unoriented. Then it is not possible to say whether that X should be resolved, so to speak, horizontally or vertically into two vortex lines. If one thinks of them as resolved into two essentially vertical vortices, one assigns a link number of one to each of them; but if they are thought of as resolved into two hairpin-shaped vortices, one of the hairpins does not pierce the Wilson surface and the other one pierces twice, but is not linked. In either case, the effect on the group-center phase factor is the same, because a link number of two contributes trivially to the Wilson-loop expectation value. For all other  $SU(N)$  the orientation does matter, and reconnection is subject to the law that the total oriented chromomagnetic flux of the vortices entering the reconnection point must be  $2\pi$  times an integer. [So for  $SU(3)$  two elementary vortices each of flux  $+2\pi/3$  pointing into the reconnection point can recombine into a third, with the same flux pointing in.] But it is easy to see that in all such cases these reconnection ambiguities do not affect the total group-center phase factor of all the vortices involved, except possibly for edge effects not contributing to the area law. However, the number of  $\lambda$ -squares occupied by reconnected vortices may differ from the number occupied by the original vortices, and this can affect certain results. For simplicity, we will assume in this paper that overlap is strictly forbidden and do not discuss reconnection ambiguities any further.

For further discussion of the ways vortices can reconnect in  $SU(N)$ , and the action penalties thereby arising, see [3].

Even for the archetypical example of a flat Wilson loop for  $SU(2)$ , inert vortices are important. In this simple case, there are many types of inert vortices, including those that pierce the surface twice within a few characteristic lengths  $\lambda$ , or that pierce it an odd number of times but have link number less than the number of pierce points. The net effect of inert vortices for a simple flat Wilson loop is that the density of linkage differs from the density of piercing by a factor  $\alpha$ , which we call the dilution factor, lying between zero and one. This factor is a rough but useful estimate of the various ways in which vortices can be inert. In Sec. III we estimate that  $\alpha$  lies in the range  $0.6 \pm 0.1$ . In the DGA, the usual result for the  $SU(2)$  fundamental string tension  $K_F$  is  $K_F = 2\rho$ ; dilution by inert vortices modifies this to

$$K_F = 2\alpha\rho. \quad (2)$$

[For  $SU(3)$ , the standard DGA gives  $K_F = 3\rho/2$ ; the diluted DGA is  $K_F = 3\alpha_3\rho/2$ , as for  $SU(2)$ . It may be that the  $SU(3)$  dilution factor  $\alpha_3$  is not precisely the same numerically as it is for  $SU(2)$ , but our estimates are not accurate enough to see much of a difference. For general  $SU(N)$  there are in principle as many dilution factors as vortex densities.]

It would, of course, be good to compare our estimates with lattice data. Unfortunately, it has turned out [4–6] to be rather difficult to calculate the density  $\rho$  on the lattice, for a number of reasons. Among these are the dependence on gauge of the center-vortex location procedures; effects of Gribov copies; and finite-size effects. Reference [5] states that lattice artifacts are so important that these authors cannot really find a reliable value for  $\rho$ . However, [6] claims a value of  $K_F/\rho$  of 1.4, which taken literally might indicate a dilution factor around 0.7, at least if the DGA is more or less correct. The best way to attack the numerical estimation of dilution might be to simulate directly a model of self-avoiding random walks, in the spirit of [1], rather than to work with QCD itself.

A second major issue arises because link numbers can be calculated (through Stokes' theorem) by counting intersections of vortices with a surface spanning the Wilson loop, but any spanning surface can be used for the link-number calculation, not just the surface that ultimately appears in the area law. So it is not clear what area is to be used in the area law, nor even why there is a unique area. We discuss these issues in Sec. IV, showing how unlinked vortices resolve the paradox of two or more possible areas for a simple Wilson loop.

The third issue, elaborated in Sec. V, is an interesting variant on the question of when vortices are linked or not. This issue was raised before at a qualitative level [7]. We consider two identical Wilson loops separated by a certain distance, and ask how the overall VEV of these two loops

depends on separation. For  $SU(2)$  this is a problem somewhat like the corresponding soap-bubble problem, where there are (at least) two minimal soap films that can appear for two wire frames close to 1 another. We can think of each loop as a  $q\bar{q}$  meson, and our results indicate a van der Waals potential between the two loops, which breaks (as also happens for soap bubbles) at a critical separation between the loops. Similar but more elaborate results hold for  $SU(3)$ .

Finally, in Sec. VI we consider the baryonic area law for  $SU(3)$ . This has been explored in center-vortex theory [8], where it is shown that the area law comes from three surfaces with quark world lines and a central line as boundaries. To some extent the baryonic area law seems to have issues like those of the double Wilson loop in Sec. V; in particular, there might appear to be correlations like the van der Waals potential of the two-loop problem that could modify the accepted baryonic area law. However, we show that analogs of the inert vortices in the two-loop problem, which are in fact not inert even though they are in the same geometry except for orientation effects, do not affect the fact that the linearly rising potential for the three quarks has precisely the mesonic string tension for each of its three sheets. Section VII contains a summary.

Except for Secs. II and III we use the DGA approximation to describe our results. But it turns out to be convenient, for these two other sections, to use a standard form [2] of the area law that contains the DGA as a limiting low-density case.

## II. BASIC PRINCIPLES FOR THE CENTER-VORTEX AREA LAW

The center-vortex picture for gauge group  $SU(N)$  invokes a vortex condensate. If  $N > 3$  there are  $N - 1$  types of vortices labeled by an integer  $k$ ,  $1 \leq k \leq N - 1$  that gives the vortex magnetic flux in units of  $2\pi/N$ . A vortex labeled  $k$  is the antivortex of the vortex labeled  $N - k$ . These vortices are characterized by an areal density  $\rho_k = \rho_{N-k}$  for each vortex type. By this areal density we mean (in all dimensions, not just  $d = 3$ ) that the average number of  $k$ -vortices that pierce any flat surface of area  $A$  is  $\rho_k A$ . There is not much theoretical insight into the values of these different densities for  $SU(N)$  with  $N \geq 3$ . However, for  $SU(2)$  and  $SU(3)$  there is only one density, which we term  $\rho$ , that sets the scale for the string tension [in  $SU(3)$  there are two types of vortices, but one is the antivortex of the other and they have the same densities]. In this paper we will only consider gauge groups  $SU(2)$  and  $SU(3)$ .

A condensate of vortices can form only if a finite fraction of them has essentially unbounded length (or an unbounded number of steps in the random walks describing the vortices). Only such vortices, long compared to any Wilson-loop scale, can contribute to the area law. These can be linked or not, depending on the circumstances we

encounter. Finite-length vortices are therefore inert, in our terminology, and will be accounted for by a renormalization factor that we will not attempt to calculate here.

Consider now a simple flat Wilson loop and the flat surface spanning it. This surface is taken to lie in a plan of the lattice dual to the vortex lattice and is divided into squares of this dual lattice; we call these  $\lambda$ -squares. Any such square is pierced by a single vortex with probability  $p$ . This probability is related to the areal density of the vortex condensate by

$$p = \rho \lambda^2; \quad (3)$$

the probability that a square is unoccupied is  $\bar{p} = 1 - p$ . As on the lattice,  $p$  can be extracted [2,4–6] from the VEV of a square Wilson-loop one lattice unit on a side. Denote this VEV as  $\langle W(1 \times 1) \rangle$ ; then for  $SU(2)$

$$\langle W(1 \times 1) \rangle = \bar{p} - p; \quad p = \frac{1}{2}[1 - \langle W(1 \times 1) \rangle]. \quad (4)$$

The only difference from the lattice definition is that in lattice computations the length scale for the Wilson loop is not a physical quantity  $\lambda$  but a lattice spacing, and the lattice version of  $p$  must be scaled via the renormalization group to find a physical probability, such as used in the present model [Eq. (3)]. Note that  $p$  is bounded by  $1/2$ , since  $\langle W(1 \times 1) \rangle$  lies between 0 and 1. Moreover, note that the probability  $p$  as derived from Eq. (4) is not subject to dilution, which applies only to large Wilson loops.

The assumption that piercings in different  $\lambda$ -squares are statistically independent leads to the standard argument for center-vortex confinement, which ignores inert vortices. In fact, certain mechanisms for inert vortices are fully equivalent to correlation effects between pierce points, as discussed below. The confining area law (discarding perimeter effects) for a Wilson loop follows from an ensemble average of center-group elements. Each of these is of the form  $\prod_i Z_i^{Lk_i}$ , where  $Z_i$  is an element of the center of the gauge group as specified by the properties of the  $i$ th vortex (and the group representation of the loop itself). For example, for the fundamental Wilson loop in  $SU(2)$  the only nontrivial element of the center has  $Z_i = -1$ . In the above product,  $Lk_i$  is the Gauss linking number of this vortex with the Wilson loop. The Gauss linking number, a topological quantity, can be written as an intersection number of the vortex and any surface spanning the Wilson loop; its (integral) value is independent of the choice of surface. In the  $SU(2)$  case the necessary average is

$$\left\langle \exp \left[ i\pi \sum_i Lk_i \right] \right\rangle. \quad (5)$$

Aside from the assumption of independent  $\lambda$ -squares, the critical assumption for expressing confinement in the center-vortex picture is that  $p$  is the probability that a vortex is actually linked once to a flat Wilson loop. When an odd number of vortices is linked once, the

Wilson loop has value  $-1$  and when an even number is linked, the value is  $+1$ . If the assumption is true, the area law follows from multiplying the probabilities  $\bar{p} - p$  of Eq. (4) for all the  $\lambda$ -squares of the spanning surface.

Another useful way of expressing this area law is to write out the combinatorics for vortex occupancy of  $N_S$  sites of a surface spanning a Wilson loop  $\Gamma$ :

$$\begin{aligned} \langle W_\Gamma \rangle &= \bar{p}^{N_S} - N_S \bar{p}^{N_S-1} p + \frac{N_S(N_S-1)}{2} \bar{p}^{N_S-2} p^2 + \dots \\ &= [\bar{p} - p]^{N_S} = [1 - 2p]^{A_S/\lambda^2}. \end{aligned} \quad (6)$$

Here the number  $N_S \gg 1$  of sites on a given spanning surface  $S$  is  $N_S = A_S/\lambda^2$ , where the surface has area  $A_S$ , and each term represents the number of ways of arranging empty and once-filled  $\lambda$ -squares.

Next we need to modify the area law for dilution, which arises from several factors: If a vortex penetrates an even number  $2N_p$  of times, there are  $N_p$  sites that lead to the unit phase factor in the Wilson-loop VEV, although these sites are occupied. In effect, the vortices filling such sites are inert (although they may, strictly speaking, be linked to the Wilson-loop topologically). Similarly, if a vortex penetrates an odd number (greater than 1) of times it is linked and gives a nontrivial phase factor, but three or more sites are occupied, rather than the single site assumed when we related the string tension and the piercing probability as in Eq. (6). We will argue in Sec. III B that the diluted form of the standard equation (6) is

$$\langle W_\Gamma \rangle = [1 - 2\alpha p]^{A_S/\lambda^2}, \quad (7)$$

yielding a string tension

$$K_F = -\frac{1}{\lambda^2} \ln(1 - 2\alpha p). \quad (8)$$

The DGA approximation is the small- $p$  limit of either Eq. (6) (undiluted) or of Eq. (8) [diluted; see Eq. (2)]. Note that, while the effect of dilution on the probability  $p$  is simply to renormalize it, the effect of dilution on a dimensionless quantity such as  $K_F/\rho$  cannot be characterized as a renormalization of a dimensionful quantity such as the density  $\rho$  or the  $\lambda$ -square area  $\lambda^2$ :

$$\frac{K_F}{\rho} = \frac{-\alpha}{x} \ln(1 - 2x)|_{x=\alpha\rho\lambda^2}. \quad (9)$$

Note that in the DGA the string tension depends on only one of two variables, the physical areal density  $\rho$ , and not on the length  $\lambda$ . Is it possible, then, that  $\lambda$  is an unphysical variable, akin to a lattice spacing? While it might be possible so to choose  $\lambda$  for the P-vortices of lattice simulations [2], whose effective thickness is no more than one lattice spacing, we will insist on a physical meaning for  $\lambda$ . Evidently beyond the DGA the string tension does depend on  $\lambda$ , as in Eq. (9).

It seems very difficult to resolve dilution problems completely by analytic methods; the best we can do is to

give a semiquantitative discussion of how these factors renormalize downward the linkage probability from  $p$ .

### III. THE DILUTION FACTOR FOR A FLAT SURFACE

In this section, dealing with the gauge group  $SU(2)$ , we distinguish between the previously introduced probability  $p$  that a vortex pierces a  $\lambda$ -square, thus contributing unit link number, and the density of link number per  $\lambda$ -square, which is what we really need. This density is reduced by inert-vortex effects. We attempt to capture, in some mean-field sense, these effects approximately by introducing a dilution factor  $\alpha$  that effectively reduces the pierce probability  $p$  to  $\alpha p$ .

We begin by classifying various ways in which vortices can pierce a spanning surface yet not be linked (in the sense that they are associated with a trivial phase factor), or are linked but are to be associated with a reduced density of linkage numbers. For brevity we refer to all these as inert vortices.

#### A. Types of inert vortices

It is useful to distinguish three types of inert vortices; only types II and III need detailed discussion. Type I vortices have finite length, and correspond in some sense to localized particles. The vortex condensate may have some of these, but they cannot explain confinement, since for large Wilson loops those that are linked contribute only to subarea effects such as perimeter terms in the VEV. Presumably the effect of such vortices is essentially to renormalize the areal density of vortices of unbounded length. We will not discuss such finite-length vortices any further, so from now on we are only concerned with the issue of vortices much longer than any Wilson-loop scale, and the extent to which these are or are not inert.

The distinction between the remaining two types of long vortices is this. Type II vortices exhibit what we will call local return, by which we mean that a vortex, however long, penetrating a localized flat surface has its highest probability of returning to that surface after only a few more steps of the random walk. This probability is not to be confused with the probability that a random walk will be near to where it has been after a large number  $N_s$  of steps; this probability decreases like  $N_s^{-d/2}$ , where  $d$  is the dimension of space-time (see the Appendix). For the present section, dealing with a flat spanning surface, this type is important, but once the renormalization of  $p$  has been made, they are not very important in the further applications of Secs. IV and V.

The essence of the type II vortices is that they lead to relatively short-range correlations between vortex piercings: Once a vortex has pierced a surface for the first time, it is more likely that there will be a nearby piercing, coming from the same vortex. In this sense, the statistics

of pierce points in the Wilson surface show correlations consistent with an attraction between pierce points, although this need not be associated with any physical attraction mechanism between vortices. Such short-range attractive correlations are indeed observed on the lattice [9].

A type III vortex is one which, having penetrated a surface, penetrates it a second time with high probability after a large number of steps. This can only be true, in view of the above remarks, if the surface is of a special type, including those used in Secs. IV, V, and VI such as a closed surface or one that has curvature radii comparable to its length scales. An infinite-length vortex must penetrate a closed surface an even number of times, therefore at least twice.

Finally, there is a category of vortices that we will ignore: Those that are inert because their link number is a nonzero multiple of  $N$  for gauge group  $SU(N)$  due to walks with a large number of steps that wind around the Wilson loop  $N$  times. These can occur for a simple flat Wilson loop and have their analog in a baryonic Wilson loop; in any case, they are less probable than the walks we do consider, and we will ignore them.

A qualitative model of type III effects might be to assume that, after renormalization for the effects of types I and II vortices, the remaining effects are seen for vortices composed of infinitely long straight lines intersecting surfaces compounded of flat segments. The rationale for the straight-line vortices is that the local returns have been accounted for by renormalization for type II vortices. In this model no vortex can return locally to a single surface element and so explicit type II vortices are missing; more than one flat surface segment must be involved, and these must form a nonplanar surface. We will not use this model in the present paper.

Among the type II vortices, the only ones to be considered in this section, there is essentially an infinite number of subtypes. Several of them are shown in Fig. 1.

The first, Fig. 1(a), shows the standard penetration assumed in the usual area-law formula of Eq. (6): Unit link number associated with a single piercing. Figure 1(b) shows an inert vortex (zero link number) produced by two additional steps from the first piercing. Figure 1(c) shows another inert vortex, using three additional steps, that makes the square labeled X inaccessible for piercing by another vortex, because of the mutual-avoidance requirement. Figure 1(d) shows a vortex with four extra steps that is linked, but has pierced three  $\lambda$ -squares, thereby again reducing the  $\lambda$ -squares available for more vortices. Note that in every case shown in the figure except for Fig. 1(a) the link number is reduced relative to the piercing number.

There are other ways for vortices to be inert, for example, a vortex may have a link number that is a multiple of  $N$  for  $SU(N)$  with  $N > 2$ . Related effects take place in the baryonic area law for  $SU(3)$  (Sec. VI).

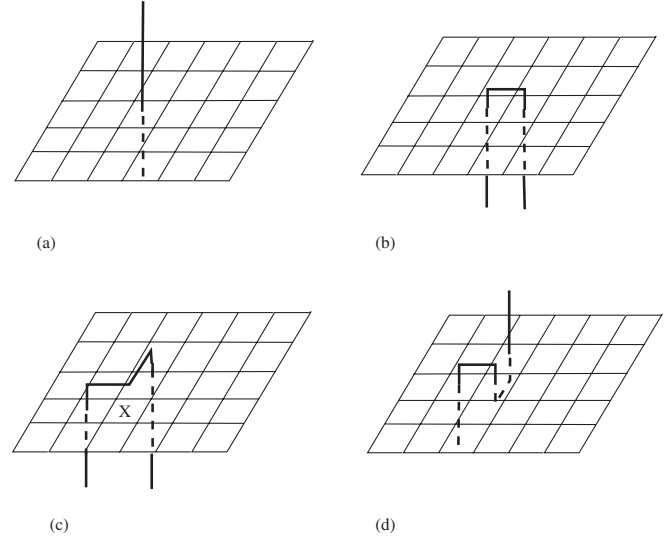

FIG. 1. In these figures, the surface being pierced lies in a plane on a lattice (shown) dual to the vortex lattice (not shown). (a) Simple piercing by a vortex (thick line). (b) An inert vortex, penetrating the surface with two more steps after the first piercing. (c) An inert vortex that has rendered the square labeled X inaccessible to another vortex. (d) A partially inert vortex, using up three  $\lambda$ -squares for a single linking.

### B. Definition of $\alpha$

The flat surface is divided, as before, into  $N_S$   $\lambda$ -squares. Of these, on the average  $pN_S$  are pierced once by a vortex, and of the pierced squares, a fraction  $\alpha$  on the average contribute to the area-law formula with a minus sign [in  $SU(2)$ ].

We use a simple statistical model, ignoring shape effects and describing the correlation between piercings via a dilution factor. It is easy to see that the coefficient of

$$\bar{p}^{K_1} (\alpha p)^{K_2} [(1 - \alpha)p]^{K_3} \left[ \sum K_i = N_S \right] \quad (10)$$

in the formal expansion of

$$1 = [\bar{p} + \alpha p + (1 - \alpha)p]^{N_S} \quad (11)$$

is the statistical weight for a configuration with  $K_2 + K_3$  pierced  $\lambda$ -squares, of which  $K_2$  are going to give a minus sign in the Wilson-loop VEV. We then have

$$\langle W \rangle = [\bar{p} - \alpha p + (1 - \alpha)p]^{N_S} = [1 - 2\alpha p]^{N_S}, \quad (12)$$

showing that, as previously specified,  $\alpha$  simply renormalizes  $p$ . For the DGA formula for the Wilson-loop VEV we find

$$\langle W_T \rangle = \exp[-2\alpha p A_S], \quad (13)$$

in which the string tension is renormalized by the factor  $\alpha$  from its previous value. The DGA is perhaps made more plausible by dilution.

Not all the effects of inert vortices can be captured by the simple dilution factor defined above. Vortices are correlated with each other through self-avoidance, as in Fig. 1(c), and the specific geometry of the portion of a random vortex walk that penetrates the spanning surface more than once can matter. Unfortunately, even simpler problems cannot be solved analytically. For example, the statistics of coexisting but mutually and self-avoiding monomers and dimers (see [10] for a mean-field approach and earlier references) has no exact solution (except in the limit of close-packed dimers [11]). This is because dimers and higher multimers do not obey simple (e.g., multinomial) statistics. One can appreciate this from the observation that on an empty lattice of  $N_S$  sites a dimer can be laid down in  $2N_S$  ways, but only  $N_S/2$  self-avoiding dimers can be put down in total. (For monomers, of course, these two numbers are the same, namely  $N_S$ .)

In the inert-vortex problem there are, in principle, a huge number of multimers, of various shapes and sizes, that should be accounted for. Rather than attempting some elaborate generalization of the monomer-dimer problem, we proceed as follows.

### III. Estimating the dilution factor

The problem is to estimate the probability that a self-avoiding random walk of infinite length, having pierced the Wilson surface (which we call  $W$ ) once, pierces it again one or more times. We need two different types of probabilities for this problem. The first is the standard probability density  $p_3(N; \vec{m})$  that a random walk on the  $d = 3$  lattice is at the lattice point  $\vec{m}$  after exactly  $N$  steps. If the difficult restriction of self-avoidance is dropped, this is given by (see, e.g., [12])

$$p_3(N; \vec{m}) = \frac{1}{(2\pi)^3 3^N} \left[ \prod_{j=1}^3 \int_0^{2\pi} d\theta_j \right] [\cos\theta_1 + \cos\theta_2 + \cos\theta_3]^N \exp[i\vec{\theta} \cdot \vec{m}]. \quad (14)$$

This is normalized so that

$$p_3(N = 0; \vec{m}) = \delta_{\vec{m}, \vec{0}} \quad (15)$$

and the sum over all  $\vec{m}$  of this density yields unity. In the limit of large  $N$  and components of  $\vec{m}$  (which is an integer-valued vector)  $p_3(N; \vec{m})$  has the usual Gaussian form. This is not the probability of real interest, although it can be used in certain circumstances to find the probability that we need. We will call the one that we do need  $q_3(N; W; \vec{m})$ , the probability density that a random walk piercing at the origin repierces for the first time at  $\vec{m}$  using exactly  $N$  steps, with the vector  $\vec{m}$  restricted to lie in the lattice plane that is nearest neighbor to the Wilson surface. The probability density  $p_3(N; W; \vec{m})$  is simply  $p_3(N; \vec{m})$  with  $\vec{m}$  restricted to the Wilson surface. Our interest is in proba-

bilities summed over the Wilson surface, so we define

$$\begin{aligned} p_3(N; W) &= \sum_{\vec{m} \in W} p_3(N; W; \vec{m}); \\ q_3(N; W) &= \sum_{\vec{m} \in W} q_3(N; W; \vec{m}). \end{aligned} \quad (16)$$

By the standard rules of probability [13]

$$p_3(N; W) = \delta_{N,0} + \sum_2^N q_3(J; W) p_3(N - J; W) \quad (17)$$

which says that the random walk, having pierced the surface for the first time after  $J$  steps, may penetrate it many times again before ending on the surface after  $N$  steps. (Note that it takes  $N = 2$  additional steps of the random walk, at minimum, to repierce the surface, given that these steps are counted as starting with the first step after the first piercing.) If the total number of piercings is odd (even) the vortex is linked (unlinked). The case of no further intersections after the first piercing is to be included; the standard area-law model of Sec. II is equivalent to assuming that this probability is unity, and all other probabilities are zero. This is far from the case, as we will see.

Equation (17) is easily solved in terms of generating functions

$$\begin{aligned} P_3(s; W) &= \sum_0^\infty p_3(N; W) s^N; \\ Q_3(s; W) &= \sum_2^\infty q_3(N; W) s^N. \end{aligned} \quad (18)$$

We have

$$\begin{aligned} P_3(s; W) &= 1 + P_3(s; W) Q_3(s; W); \\ Q_3(s; W) &= 1 - \frac{1}{P_3(s; W)}. \end{aligned} \quad (19)$$

Note that we may express the elementary solution for  $P_3(s; W)$ , which is

$$P_3(s; W) = \frac{1}{1 - Q_3(s; W)}, \quad (20)$$

in a suggestive way for the original probabilities:

$$\begin{aligned} p_3(N; W) &= \delta_{N,0} + q_3(N; W) \\ &+ \sum q_3(K; W) q_3(N - K; W) \dots \end{aligned} \quad (21)$$

showing how the probability  $p_3$  is compounded from probabilities of first return [see, e.g., Fig. 1(d)].

The final probability of interest is the probability that the random walk ever repierces the surface; this is clearly given by the sum of all the  $q_3$ , or by  $Q_3(s = 1; W)$ .

Equation (19) also holds in certain other problems, notably the gambler's ruin problem (described in the Appendix), which asks for the probability that a  $d = 1$

random walk starting at the origin ever returns to it. In this problem backtracking (retracing the last step) is allowed, and (as we review in the Appendix) it is straightforward to show that the corresponding probability of ever returning is exactly unity. It is also unity in two dimensions. However, our problem differs from the gambler's ruin problem in two essential ways: No backtracking is allowed, and ultimately the problem becomes three-dimensional, when the radius of gyration  $N^{1/2}$  of the random walk becomes large compared to the size scale  $L$  of the Wilson loop. (Actually, the radius of gyration for self-avoiding walks has an exponent somewhat different from  $1/2$ , but we ignore that complication here.) It has long been known (as reviewed in [12]) that the probability of return to the origin in  $d = 3$  is finite, with a value of approximately 0.34. Furthermore, self-avoidance completely changes the problem; for example, a self-avoiding "random" walk in  $d = 1$  has probability zero of ever returning to any site it has reached.

Let  $\mathcal{P}$  be the probability that a vortex, having penetrated the Wilson surface once, never penetrates it again. Then, with  $Q_3(1; W)$  as the probability that it ever penetrates the surface again,

$$\mathcal{P} = 1 - Q_3(1; W). \quad (22)$$

Or one may write, as in Eq. (21), a probability sum rule saying that the sum of probabilities of piercing exactly once, exactly twice, etc., must be unity:

$$1 = \mathcal{P} \left\{ 1 + \sum q_3(K; W) + \left[ \sum q_3(K; W) \right]^2 + \dots \right\}. \quad (23)$$

As before, the sum over  $K$  begins with 2 for self-avoiding random walks.

It is now necessary to estimate  $\mathcal{P}$ , or equivalently  $Q_3(1; W)$ . Unfortunately, this is not a straightforward matter when there is self-avoidance (see the Appendix for a brief review of some of the well-known analysis when this condition is not imposed). One way to proceed is simply to count the number of self-avoiding paths going from an original piercing to another piercing as a function of their step length, and look for ways of partially resumming the results. Our proposal, given below, is more accurate for random walks that do not backtrack than for true self-avoiding walks; the difference is that a nonbacktracking walk may violate the condition of self-avoidance by looping back on itself. We propose the following expression for nonbacktracking walks, valid for  $J \geq 2$ :

$$q_3(J; W) = \left(\frac{4}{25}\right) \frac{1}{2} \left[ \left(\frac{3}{5} + \frac{1}{5}\right)^{J-2} + \left(\frac{3}{5} - \frac{1}{5}\right)^{J-2} \right]. \quad (24)$$

The corresponding generating function, approximately valid for self-avoiding walks, is

$$Q_3(s; W) = \left(\frac{2}{25}\right) \left[ \frac{1}{1 - (4s/5)} + \frac{1}{1 - (2s/5)} \right]. \quad (25)$$

The explanation of the terms is as follows. The factor  $4/25$  is the probability for Fig. 1(b), for  $J = 2$ . For a nonbacktracking walk in  $d = 3$  there are 5 possible choices to add a new step to the random walk. The horizontal step in this figure has probability  $4/5$  (note that we are summing over all possible sites), and the next, vertical, step has probability  $1/5$ . The appearance at larger  $J$  of  $3/5$  in the formula expresses the probability that a nonbacktracking random walk will take its next step horizontally (with respect to the Wilson surface), and  $1/5$  is the probability of a vertical step in one particular direction (up or down). (The restriction to even powers of  $1/5$  is easily understood by drawing a few figures, in the style of Fig. 1.) So a random walk once started in a horizontal plane has a 3 times larger probability of staying in that plane than of moving to a plane higher above the Wilson surface. It is easy to check the combinatorics of the low-order powers of  $1/5$  in Eq. (24), and also the highest powers, for example, the last term  $(4/25) \times (1/5)^{J-2}$ . This is the probability that the random walk goes as high as possible, takes one horizontal step, and then returns straight down to the Wilson surface. This can only happen for even  $J$ , and one easily sees that the maximum attainable height is  $J/2$ . We have compared the approximation of Eq. (24) with explicit counting of self-avoiding walks through  $J = 8$  and find that the difference between self-avoiding and nonbacktracking is acceptably small.

The difference between nonbacktracking walks and self-avoiding walks first appears at  $N = 5$ , where there are 144 nonbacktracking walks but only 128 self-avoiding walks. This is about an 11% error, but because the erroneous contribution to the  $N = 5$  walks is  $16/3125 \approx 0.0052$ , out of a total of about 0.533, the error in the final result from  $N = 5$  terms is less than 1%. In any case, to deal with true self-avoidance rather than just nonbacktracking raises the same issues as having a condensate of mutually avoiding vortices, and we do not discuss that issue in any detail in this paper.

We find an approximation to  $Q_3(1; W)$  by summing over all  $J$  in Eq. (24), with the result

$$\begin{aligned} Q_3(1; W) &\approx \left(\frac{4}{25}\right) \frac{1}{2} \left[ \frac{1}{1 - (4/5)} + \frac{1}{1 - (2/5)} \right] = \frac{8}{15} \\ &\approx 0.533. \end{aligned} \quad (26)$$

At this point one might guess that the dilution factor  $\alpha$  should be equal to the probability  $\mathcal{P}$  of never returning. But this is not quite right; we really need the probability of being linked or unlinked. To do this, one should separately find the probabilities that there is an even or odd number of piercings, as expressed by separating the even and odd powers of  $Q_3(1)$  in Eq. (23). We use  $\mathcal{P}_L$  for the probability that a vortex is linked, and  $\mathcal{P}_U$  for the probability that it is unlinked; these are defined by



$$\mathcal{P}_L = \mathcal{P} \left\{ 1 + \sum_{\text{even}} Q_3(1)^N \right\} = \frac{1}{1 + Q_3(1)}; \quad (27)$$

$$\mathcal{P}_U = \mathcal{P} \sum_{\text{odd}} Q_3(1)^N = \frac{Q_3(1)}{1 + Q_3(1)}.$$

Now it seems that  $\alpha = \mathcal{P}_L$ . If we to use our approximation  $Q_3(1) = 0.53$  we would find the link probability (dilution factor) to be about 0.65, somewhat larger because we are counting three, five, ... piercings as well as a single piercing.

Equation (27) is not quite right either, because while  $\mathcal{P}_L$  expresses the probability of linkage, when (say) three sites are used for the link instead of one, there is dilution that must be accounted for. We account for this by calculating a sum of weighted probabilities, where the weight for the appearance of  $K$  powers of  $Q_3(1)$  in Eq. (27) is the inverse of the number of sites occupied by the linked vortex, or  $(K + 1)^{-1}$ . For example, when  $K = 2$  three  $\lambda$ -squares are pierced, as shown in Fig. 1(d). This result for  $\alpha$ , when modified by the original piercing probability  $p$ , should give something like the link number per unit area, in effect increasing the size of  $\lambda$ -squares to account dilution. The weighted sum for  $\mathcal{P}_L$  gives another estimate for  $\alpha$ :

$$\alpha \approx \mathcal{P} \left\{ \sum_{\text{even}} \frac{Q_3(1)^N}{N + 1} \right\} = \frac{1 - Q_3(1)}{2Q_3(1)} \ln \left[ \frac{1 + Q_3(1)}{1 - Q_3(1)} \right]. \quad (28)$$

For  $Q_3(1) = 0.53$  this gives  $\alpha = 0.52$ .

It is plausible that  $Q_3(1; W)$  lies between the no-self-avoidance  $d = 3$  value of 0.34 and the  $d = 1$  value of 1. In that case, the estimate of  $\alpha$  with no inverse-site weighting [Eq. (27)] gives a finite value even in the  $d = 1$  limit, where we find  $\mathcal{P}_L = \mathcal{P}_U = 1/2$ , so the dilution factor is  $1/2$ . This is a singular limit, because the original probability  $\mathcal{P}$  used to construct  $\mathcal{P}_L, \mathcal{P}_U$  vanishes, but this is canceled by a singularity in the sum over  $Q$ s. It is not surprising that the limiting probabilities are each  $1/2$ , since there is no way of distinguishing an even number of piercings from an odd number. The value of  $\alpha$  from this equation for the  $d = 3$  value  $Q_3(1; W) = 0.34$  is about 0.75. Equation (28), with inverse-site weighting, gives 0.75 for  $Q_3(1; W) = 0.34$  and 0 for  $Q_3(1; W) = 1$ . Presumably this latter case is unrealistic, because at some point the radius of gyration of the random walk is large compared to the Wilson-loop scale  $L$  and the problem really is three-dimensional; in any case, the  $d = 1$  self-avoiding case is completely opposite to the no-self-avoidance case.

To be more accurate in estimating  $\alpha$ , one would need to account for mutual-avoidance effects such as shown in Fig. 1(c), and be more precise about weighting various random-walk configurations. We will not attempt that here, and close by saying that our estimates for the dilution factor are consistent with  $\alpha = 0.6 \pm 0.1$ .

In the following sections we look for further manifestations of inert vortices of type III, going beyond the local

effects that led to the dilution factor. But these local effects still occur, and so everywhere in our arguments the original probability  $p$  should be replaced by the diluted probabilities

$$\hat{p} \equiv \alpha p; \quad \bar{p} \equiv 1 - \hat{p}. \quad (29)$$

#### IV. INERT VORTICES AND THE SPANNING SURFACE

Now we return to the problem that the spanning surface used for counting link numbers as piercings is arbitrary, yet there surely is a unique area in the area law. The simplest possible case, where there is no doubt as to the answer, is that of a flat Wilson loop, and one can get the right area law by using the flat spanning surface in Stokes' theorem. Yet one should also get the right answer by using any other surface. How does this come about?

Figure 2 shows such a flat Wilson loop, with two spanning surfaces. The first, labeled  $\Sigma$ , is flat and is correct. The second is labeled  $S$ . We choose orientations so that the combined surface  $\Sigma + S$  is oriented. Of course, this surface is closed.

We must now improve upon the techniques outlined in Sec. IV, to account for inert vortices of type III. The calculation of the area law based on the flat surface  $\Sigma$  needs no change. But what if we instead wished to calculate the area law based on surface  $S$ ? Here there is extra dilution. The vortices linked to surface  $S$  are still those linked to surface  $\Sigma$ , which must pass through surface  $\Sigma$  and surface  $S$  once each, but there are also inert vortices, which pass through surface  $S$  twice and surface  $\Sigma$  not at all. (We will not account for vortices linking three, five, ... times, most of which are included in the dilution factor.) We denote the number of linked vortices by  $N_L$  and the number of inert vortices by  $N_I/2$ . The factor of  $1/2$  in the latter definition simply reflects the fact that every inert vortex pierces surface  $S$  twice, so that  $N_I$  is the total number of pierce points of inert vortices. It is not convenient to introduce this factor of  $1/2$  for linked vortices, because

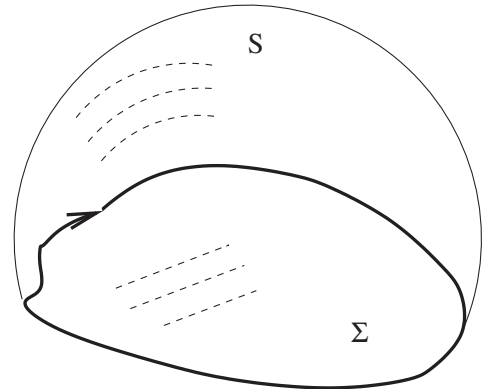

FIG. 2. A flat Wilson loop, and two spanning surfaces, labeled  $\Sigma$  and  $S$ .



the diluted pierce probability  $\hat{p}$ , introduced above, is related to the number  $N_L$  of vortices linked to surface  $\Sigma$  by

$$N_L = \frac{\hat{p}A_\Sigma}{\lambda^2} \quad (30)$$

where  $A_\Sigma$  is the area of surface  $\Sigma$ . That is,  $N_L$  is the number of pierce points of vortices on surface  $\Sigma$ .

The total number of vortex piercings of the combined surface  $\Sigma + S$ , denoted  $N_{\text{tot}}$ , is

$$N_{\text{tot}} = 2N_L + N_I, \quad (31)$$

with the two arising because linked vortices penetrate both surface  $S$  and surface  $\Sigma$ . By hypothesis of a uniform areal density of vortices, this total number of vortex pierce points on the combined surface  $\Sigma + S$  is also given by

$$N_{\text{tot}} = \frac{\hat{p}(A_\Sigma + A_S)}{\lambda^2}. \quad (32)$$

Combining these equations, one finds

$$N_I = \frac{\hat{p}(A_S - A_\Sigma)}{\lambda^2}. \quad (33)$$

To calculate the area law in the DGA, we can easily use the formulas of Sec. II for the flat  $\Sigma$  surface, which has a total of  $N_\Sigma = A_\Sigma/\lambda^2$   $\lambda$ -squares:

$$\langle W \rangle = [\bar{p} - \hat{p}]^{N_\Sigma} \rightarrow e^{-K_F A_\Sigma}, \quad (34)$$

with  $K_F = 2\hat{p}/\lambda^2$  as before. It is more interesting to calculate it from the point of view of the other spanning surface  $S$ . Here we must account for the diminished probability of occupation of this surface by linked vortices, since some of them, as counted by  $N_I$ , are inert. So we change the probabilities by adding to  $\bar{p}$ , the probability of no occupation, the probability  $\hat{p}_I \equiv N_I/N_S$  of occupation by an inert vortex of type III. This gives

$$\bar{p} \rightarrow \tilde{p}_0 = \bar{p} + \hat{p}_I = \bar{p} + \hat{p}\left(1 - \frac{A_\Sigma}{A_S}\right) = 1 - \frac{\hat{p}A_\Sigma}{A_S}. \quad (35)$$

Similarly, the new link probability  $\tilde{p} \equiv 1 - \tilde{p}_0$  is

$$\tilde{p} = \frac{\hat{p}A_\Sigma}{A_S}. \quad (36)$$

Using Eq. (34) with the new probabilities for the surface  $S$  one gets, going to the DGA limit as before,

$$\langle W \rangle = [\tilde{p}_0 - \tilde{p}]^{N_S} \rightarrow e^{-2(\tilde{p}/\lambda^2)A_S} = e^{-2(\hat{p}/\lambda^2)A_\Sigma}. \quad (37)$$

## V. COMPOUND WILSON LOOPS

Consider the compound Wilson loop shown  $W_{\text{comp}}$  in Fig. 3, composed of two identical but oppositely oriented Wilson loops. [The orientation is irrelevant in  $SU(2)$ .] They are separated transversely by a distance  $z$ . The rele-

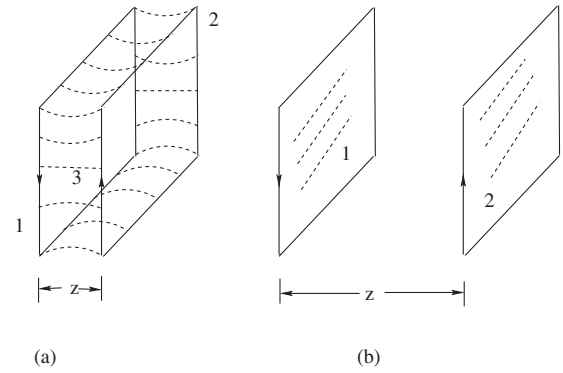

FIG. 3. Two identical but oppositely oriented rectangular Wilson loops 1 and 2, separated by a distance  $z$ . (a) When  $z$  is small compared to loop scales, the Wilson-loop area, labeled 3, connects the loops. (b) When  $z$  is large, the Wilson-loop areas are the disjoint areas, labeled 1 and 2, of each loop.

vant expectation value is

$$\langle W_{\text{comp}} \rangle = \langle W(1)W^\dagger(2) \rangle. \quad (38)$$

When the distance  $z$  between the loops is small compared to the loop, intuition [7] suggests that the surface whose area should appear in the area law, as in Eq. (1), is the minimal surface 3 joining the two loops as shown in Fig. 3(a). When  $z$  is large, intuition suggests that the situation in Fig. 3(b) holds, where each loop is spanned by its own minimal surface with no connection to the other surface. We will show that intuition is indeed correct for the compound area law of center-vortex theory, and give an approximate interpolation formula for intermediate values of  $z$ .

Begin with the  $SU(2)$  case, where the orientation of the Wilson loop does not matter, and  $W = W^\dagger$ . As usual, we assume that the time extent  $T$ , the spatial extent  $R$  of the Wilson loop, and their separation  $z$  are all large compared to the QCD scale length  $\lambda$  and assume that  $T \gg R$ . In this limit the spanning surface  $S_3$  of Fig. 3(a) is nearly flat, and has area  $A_3 \simeq 2zT$ . (We ignore the contribution  $\simeq 2zR$  from the top and bottom.) The Wilson-loop surfaces  $S_{1,2}$  have areas  $A_1 = A_2 = RT$ .

Imagine now a configuration where all surfaces  $S_{1,2,3}$  exist, so that there is a closed surface with two marked contours, the Wilson loops 1 and 2. This constitutes a minor generalization of the configuration already considered in Sec. IV. There are several ways that vortices can be linked or inert (in the sense of Sec. III A), after the renormalization of type I and type II vortices. Use the notation  $N_i$  for the total number of vortices penetrating surface  $S_i$ . These obey

$$N_i = \frac{\hat{p}A_i}{\lambda^2}. \quad (39)$$

Each of these is subdivided as follows: The number of vortices piercing  $S_1$  and  $S_3$  an odd number of times is

called  $N_{13}$ , with analogous notation for  $N_{23} = N_{13}$ ; the number piercing surface  $S_1$  and  $S_2$  each an odd number of times is  $N_{12}$ ; and the number entering  $S_3$  and then exiting the same surface is  $N_{33}$ .

As indicated in the Appendix, the probability that a vortex known to be at a point remote from a surface that then penetrates the surface (once) is proportional to the surface area, and is finite when the QCD scale length  $\lambda$  vanishes. If we require the number of vortices penetrating one surface, say  $S_1$ , and then another surface, say  $S_2$ , that probability is proportional to  $A_1 A_2$ . So we now assume that

$$N_{12} \sim A_1 A_2 = A_1^2; \quad N_{13} \sim A_1 A_3; \quad N_{33} \sim A_3^2. \quad (40)$$

These vortex-linking numbers are related to the total vortex-piercing numbers by

$$N_1 = N_{12} + N_{13}; \quad N_3 = 2N_{13} + N_{33}. \quad (41)$$

Equations (39)–(41) are easily solved to yield

$$N_{12} = \frac{2\hat{p}A_1^2}{\lambda^2(2A_1 + A_3)}; \quad N_{13} = \frac{\hat{p}A_1 A_3}{\lambda^2(2A_1 + A_3)}; \quad (42)$$

$$N_{33} = \frac{\hat{p}A_3^2}{\lambda^2(2A_1 + A_3)}.$$

We will now compute the expectation value  $\langle W \rangle$  of the product  $W \equiv W_1 W_2$  of the two Wilson loops, from the point of view of the surfaces  $S_{1,2}$ . Only the number  $N_{13}$  contributes nontrivially to an  $SU(2)$  Wilson loop. As in Sec. IV we introduce modified probabilities

$$\tilde{p}_1 \equiv \frac{\lambda^2 N_{13}}{A_1} = \frac{\hat{p}A_3}{2A_1 + A_3}; \quad \tilde{p}_0 = 1 - \tilde{p}. \quad (43)$$

Just as in calculating the Wilson-loop VEV from Eq. (37), we have the following in the DGA:

$$\langle W_{\text{comp}} \rangle = (\tilde{p}_0 - \tilde{p})^{2A_1/\lambda^2} \rightarrow \exp\left[-\frac{2K_F A_1 A_3}{2A_1 + A_3}\right]$$

$$= \exp\left[-\frac{2K_F T R z}{R + z}\right]. \quad (44)$$

This formula is only approximate, but it shows features that we believe are generally correct (and one feature that is not correct). For example, the heavy-quark potential  $V$  [coefficient of  $-T$  in the exponent of Eq. (44)] has the behavior  $V \simeq 2K_F z$  in the limit  $z \ll R$ , showing that the area law of two  $SU(2)$  Wilson loops [or, as in Fig. 3, two oppositely directed Wilson loops] disappears as the two loops approach each other and form an  $N$ -ality zero configuration. (For  $N$ -ality zero loops there is a pseudo-area law, coming from the finite size of vortices [14], at distances  $z \sim \lambda$ , but that is irrelevant here.) In the opposite limit of  $z \gg R$  we find  $V = 2K_F R$ , so the VEV is just the product of the separate VEVs for two Wilson loops. While this in itself is correct, the approach to this limit cannot be,

for it would yield a residual potential  $V - 2K_F R$  which vanishes only like  $1/z$ . In actuality, at some point when  $R \simeq z$  the spanning surface switches on the length scale  $\lambda$  from  $S_3$  to  $S_1 + S_2$ , much as the corresponding soap-bubble surface would for two physical wire loops 1 and 2. We do not see this breaking because we have not included effects coming from a network of gluon world lines running from loop 1 to loop 1, from loop 2 to loop 2, and from loop 1 to loop 2. The simplest step in the formation of this network has been discussed [15] in connection with baryonic and mesonic hybrids, having extra gluons along with their quark content. There it is shown that a single gluon acts like a physical string which separates a Wilson-loop spanning surface into two surfaces, and the string requires extra energy to be stretched if the string stretching leaves the minimal spanning surface. The fluctuations associated with this stretching should yield the Lüscher [16] term, as well as leading to the transition from surface  $S_3$  to  $S_1 + S_2$  as the gluons in the network recombine. But when this stretching is not too great the potential should behave roughly as given in Eq. (44).

In  $SU(N)$  with  $N > 2$  the orientation of the Wilson loops does matter. If the loops have opposite orientation, as shown in Fig. 3, the problem is essentially the same as for  $SU(2)$ . But one should also consider the problem of two loops of the same orientation. Since for  $SU(3)$  the treatment of this problem is quite similar to that for the baryon, which is a compound of three Wilson loops, we defer further discussion to Sec. VI.

## VI. VORTICES ANALOGOUS TO INERT VORTICES AND THE BARYONIC AREA LAW

It is by now well-established both in center-vortex theory [8] and on the lattice [17,18] that, as shown in Fig. 4, in  $SU(3)$  the heavy-quark baryonic potential has three Wilson-loop surfaces spanning a boundary consisting of

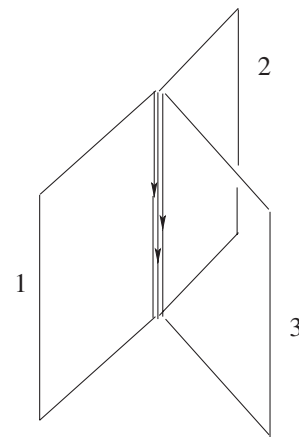

FIG. 4. A baryonic Wilson loop in  $SU(3)$  is composed of three simple Wilson loops sharing a common central line (expanded in the figure). The central line is invisible to  $SU(3)$  center vortices.

the quark world lines, with the three Wilson loops coinciding along a central line (the so-called Y law). The Y law also emerges [19] from lattice studies of center vortices as random surfaces [1].

This is a threefold compound Wilson loop, sharing some of the features of the double loop discussed in Sec. V. In particular, a vortex may pierce two loops. Such a vortex is not inert, as were the vortices piercing surfaces 1 and 2 of Fig. 3 and discussed in the previous section. Instead, linkage with these analogs of inert vortices are important to establish that the string tension in the baryonic area law is precisely the mesonic string tension  $K_F$ .

Of course, it is also possible that a vortex can pierce all three Wilson loops in turn; such a vortex is genuinely inert. This possibility occurs with lesser probability than the piercing of two loops, and is roughly comparable to the possibility that a vortex piercing an  $SU(3)$  mesonic Wilson loop has link number 3 due to 3 windings of the vortex around the Wilson loop and is thus inert; we have mentioned in Sec. III A that we will ignore such windings, generally less probable than those considered.

The analysis of the dilution factor  $\alpha$  for  $SU(3)$  is slightly more complicated, because a vortex piercing twice is not unlinked as it is in  $SU(2)$ ; it is simply equivalent to an antivortex piercing once. Given the complete symmetry between vortex and antivortex, this means that an antivortex piercing twice is equivalent to a vortex piercing once. There is a modification of the numerical value of the dilution factor, since it is now possible to dilute unit link number by occupying a minimum of two sites, rather than a minimum of three as for  $SU(2)$ . However, the string tension is still lessened by a single dilution factor  $\alpha$ , just as for  $SU(2)$ , and we can continue to use the notation developed for that case. We will not pursue the question of what the value of the dilution factor is for  $SU(3)$ ; it must be quite similar to that for  $SU(2)$ .

The  $SU(3)$  version of the standard area law for a single Wilson loop, given in Eq. (6) for  $SU(2)$ , is

$$\begin{aligned} \langle W \rangle &= \left\{ \bar{p} + \frac{\hat{p}}{2} \left[ e^{2\pi i/3} + e^{-2\pi i/3} \right] \right\}^{A_S/\lambda^2} \\ &= \left[ 1 - \frac{3\hat{p}}{2} \right]^{A_S/\lambda^2}. \end{aligned} \quad (45)$$

Here we use  $\hat{p}/2$  as the probability (accounting for dilution) that a vortex of flux  $2\pi/3$  pierces the surface, with equal probability that the antivortex of flux  $-2\pi/3$  pierces it; this means that, as before,  $\bar{p} = 1 - \hat{p}$ . This leads immediately to the DGA  $SU(3)$  string tension  $K_F = 3\hat{p}\lambda^{-2}/2$ .

To discuss the baryonic area law in similar terms to those used with the double Wilson loop, introduce a surface made of flat pieces, labeled 4 and shown in Fig. 5, that forms a closed surface when combined with the surfaces spanning Wilson loops 1 and 3.

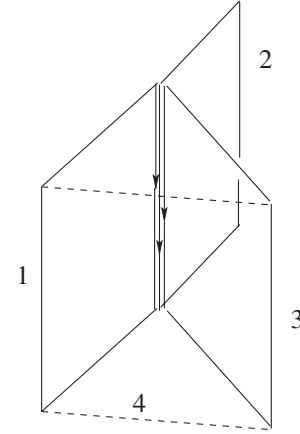

FIG. 5. We introduce a new surface labeled 4 that creates a closed surface consisting of the two Wilson-loop surfaces for quarks 1 and 3 plus a surface joining these.

In what follows we will be careful to distinguish vortices from antivortices, although at the end the symmetry between them makes this simply a distinction for convenience of exposition. As in Sec. V we introduce the number  $N_{13}$  as the number of times that a given vortex (not antivortex) is linked to both spanning surface 1 and surface 3 (that is, pierces each of these surfaces an odd number of times), and  $N_{14}$  is defined analogously for surfaces 1 and 4. We consider that the dilution factor  $\alpha$  has been applied, so we can take this odd number to be just one. The number  $N_1$  is the number of vortex piercings on surface 1, and it obeys

$$N_1 = \frac{\hat{p}A_1}{2\lambda^2} = N_{13} + N_{14}. \quad (46)$$

The factor of 2 in the denominator arises because there are just as many antivortices piercing any given surface; it is the same factor of 2 dividing the explicit probabilities in the area law of Eq. (45).

Any vortex that pierces surface 1 once must leave through either surface 3 or surface 4. If it leaves through surface 4 it is associated with a phase factor  $\exp[2\pi i/3]$ ; if it leaves through surface 3 it is associated with a phase factor  $\exp[-2\pi i/3]$ . For any such vortex configuration there is an equally probable antivortex configuration, with the phase factors interchanged. So the *total* number of piercing, vortices plus antivortices, is  $2N_1$ , and the number of antivortices piercing surface 3 is  $N_{13}$ , etc. This, plus the relation of Eq. (46), means that the standard calculation of the baryonic area law using surface 1 (plus surfaces 2 and 3), giving the Y law, is exactly the same as accounting for the linkages of vortices and antivortices through surfaces 1 and 4, plus linkages through surfaces 1 and 3 (plus permutations for the other two quarks). There really are no unlinked type III vortices in this problem, the way there were in Secs. IV and V. The baryonic string tension is precisely the mesonic string tension, because

when it is calculated from the three quark surfaces 1, 2, and 3 separately, without regard to the other two quarks, it is just the standard simple Wilson-loop calculation. But it is just the same when linkages to two quarks are considered. Of course, no one doubted the equality of string tensions for baryons and mesons, but the point was to see how it worked out in the center-vortex picture.

## VII. SUMMARY AND CONCLUSIONS

We have discussed semiquantitatively some of the effects of inert vortices that do not couple as effectively as they might to a Wilson loop, and that change the probability of linkage by a dilution factor  $\alpha \leq 1$ . In turn, this changes the  $SU(2)$  DGA string tension from  $K_F = 2\rho$  to  $K_F = 2\alpha\rho$ , where  $\rho$  is the areal density of vortices piercing a large flat surface. Our estimate, based on partial sums of nonbacktracking walks, is  $\alpha = 0.6 \pm 0.1$ . Understanding inert vortices also leads to understanding of how it is that there is a unique area in the area law, even though any surface spanning a Wilson loop is suitable for counting link numbers in the center-vortex picture. We found a finite-range van der Waals force, due to inert vortices, that links two mesonic Wilson loops, in this case vortices that are simultaneously linked to both Wilson loops. And finally we showed that the analogs of inert vortices in the two-loop problem do not interfere with the usual formulation of the area law for  $SU(3)$  baryons, based on considering the three Wilson loops as independent.

There seems to be no possibility of a detailed analytic approach to these problems, which therefore are best studied further with lattice computations. One can, of course, create a center-vortex condensate through simulation of the underlying non-Abelian gauge theory, but it would also be very interesting and possibly simpler to study inert-vortex effects with simulations that begin with an *a priori* vortex model, similar in spirit to the approach of [1], rather than having to deal with all the complications of the full gauge theory. Indeed, it seems that relating  $K_F$  and  $\rho$  on the lattice has numerous complications [4–6], and has not been attempted recently. But the simulation of two Wilson loops seems approachable on the lattice.

## APPENDIX A: PROBABILITY ISSUES

This appendix discusses two issues: (1) A brief review of well-known analysis for return probabilities for random walks with backtracking allowed; (2) The probability for a vortex to pierce two separated Wilson loops. The first serves for cautionary notes in the problem calculating the dilution factor of Sec. III, and the second arises in finding the area law for the compound Wilson loop of Sec. V. For the most part and for dimension  $d \leq 4$ , analytic results are only available for random walks without self-avoidance

constraints, and we will only discuss those in the next subsection.

### 1. The gambler's ruin problem [Sec. III]

The only problems that one has any real chance to analyze are for non-self-avoiding walks, and we will review a famous one, the gambler's ruin problem, here. The basic probability concepts are the same for self-avoiding walks, and so this review should be helpful to those unfamiliar with the underlying ideas. The cautionary note here is that while the  $d = 1$  gambler's ruin problem seems superficially quite similar to those of Sec. III, in practice they are very different, both because the questions of Sec. III have three-dimensional effects and because they deal with self-avoiding walks.

We ask for the probability  $q_1(K; m)$  that an unbiased random walk starting from the origin on a lattice of points in  $d = 1$  will return to the point  $m \geq 0$  for the first time after  $K$  steps. The case  $m = 0$  is the standard gambler's ruin problem. For an unbiased walk [all step probabilities equal to  $1/(2d)$  in  $d$  dimensions] Pólya long ago proved that in the limit of infinite steps the probability of return to the origin is unity in  $d = 1, 2$  but less than one in all other dimensions. This is perhaps plausible from the fact that the probability of being at the origin after  $N$  steps in  $d$  dimensions is, for  $N \gg 1$ ,

$$p_d(N) \sim N^{-d/2}, \quad (\text{A1})$$

and the sum over  $N$  diverges at large  $N$  in  $d = 1, 2$  but not in higher dimensions.

As in Sec. III, the relation between the  $p_1(N; m)$  and the  $q_1(N; m)$  is

$$p_1(N; m) = \sum_{J=1}^N p_1(N - J; m = 0)q_1(J; m) \quad (\text{A2})$$

$$(p_1(N = 0; m) = \delta_{m,0}).$$

Note that in the sum on the right  $p_1$  has  $m$  set equal to zero, because we are compounding the probability of first return to  $m$ , as given by  $q_1$ , with the probability of being at this same point  $m$  after more steps.

To solve these relations, define the generating functions  $P_1(s; m)$  and  $Q_1(s; m)$ :

$$P_1(s; m) = \sum_0^{\infty} p_1(N; m)s^N; \quad (\text{A3})$$

$$Q_1(s; m) = \sum_2^{\infty} q_1(N; m)s^N.$$

Equation (A2) then translates to

$$P_1(s; m) = \delta_{m,0} + Q_1(s; m)P_1(s; 0). \quad (\text{A4})$$

It is straightforward to find  $p_1(N; m)$  and  $P_1(s; m)$ . The probability  $p_1(N; m)$  is the standard random-walk probability, given by [12]

$$p_1(N; m) = \frac{1}{2\pi} \int_0^{2\pi} d\theta [\cos\theta]^N \exp[im\theta]. \quad (\text{A5})$$

From this we find the generating function (for  $m \geq 0$ )

$$\begin{aligned} P_1(s; m) &= \frac{1}{2\pi} \int_0^{2\pi} d\theta \frac{e^{im\theta}}{1 - s \cos\theta} \\ &= \left\{ \frac{1}{s} [1 - (1 - s^2)^{1/2}] \right\}^m (1 - s^2)^{-1/2}, \end{aligned} \quad (\text{A6})$$

and the gambler's ruin ( $m = 0$ ) generating function is

$$P_1(s; m = 0) = [1 - s^2]^{-1/2}. \quad (\text{A7})$$

This yields for the gambler's ruin problem the well-known result

$$Q_1(s; m = 0) = 1 - P_1(s; m = 0)^{-1} = 1 - [1 - s^2]^{1/2}. \quad (\text{A8})$$

One learns from this that the probabilities for first return after  $K = 2, 4, 6, 8, \dots$  steps are  $1/2, 1/8, 1/16, 5/128, \dots$  independent of the total number of steps in the random walk (if this number is larger than  $K$ ), and that the probability of ever returning is unity. This follows from Eqs. (A1) and (A3), which shows that  $P_1(1)$  diverges in  $d = 1$  (and also in  $d = 2$ ) but not in higher dimensions.

For nonzero  $m$  we have

$$P_1(s; m) = Q_1(s; M) P_1(s; m = 0). \quad (\text{A9})$$

It then follows from Eqs. (A6), (A7), and (A9) that

$$Q_1(s; m) = \left\{ \frac{1}{s} [1 - (1 - s^2)^{1/2}] \right\}^m. \quad (\text{A10})$$

By expanding in  $s$ , one sees that the probabilities vanish for  $N < m$ , as expected, and by setting  $s = 1$  in  $Q_1(s; m)$  one sees that the probability of ever reaching  $m$  is unity. The probability  $q_1(N; m)$  peaks for  $N \sim m^2$ , when  $m$  is comparable to the vortex radius of gyration.

Now consider calculating the probability of first return anywhere on an infinite plane in  $d = 3$ . The probability  $p_3(N; \vec{m})$  of going from the origin to lattice point  $\vec{m}$  in  $N$  steps on an infinite lattice is given in Eq. (14) and the corresponding generating function is

$$\begin{aligned} P_3(s; \vec{m}) &= \frac{1}{(2\pi)^3} \left[ \prod_{j=1}^3 \int_0^{2\pi} d\theta_j \right] \left\{ 1 - \frac{s}{3} [\cos\theta_1 + \cos\theta_2 \right. \\ &\quad \left. + \cos\theta_3] \right\}^{-1} \exp[i\vec{\theta} \cdot \vec{m}]; \\ P_3(0; \vec{m}) &= \delta_{\vec{m}, \vec{0}}. \end{aligned} \quad (\text{A11})$$

Take  $m_3 = 0$  in Eq. (A11) and sum from  $-\infty$  to  $\infty$  over  $m_{1,2}$ . The result is, not unexpectedly, a simple variant on the  $d = 1$  gambler's ruin problem, and yields

$$\begin{aligned} P_3(s) &\equiv \sum_{m_1, m_2 = -\infty}^{\infty} P_3(s; m_1, m_2, m_3 = 0) \\ &= \frac{1}{\pi} \int_0^\pi \frac{d\theta}{1 - \frac{2s}{3} - \frac{s}{3} \cos\theta} = \left[ 1 - \frac{4s}{3} + \frac{s^2}{3} \right]^{-1/2}. \end{aligned} \quad (\text{A12})$$

Using a standard expansion and Eq. (A8) we find the probabilities  $q_3(K)$ :

$$q_3(K) = -3^{-K/2} C_K^{-1/2} \left( \frac{2}{\sqrt{3}} \right) \quad (\text{A13})$$

where the  $C_K^{-1/2}$  are Gegenbauer polynomials.

## 2. Probability that a vortex pierces two separated Wilson loops [Sec. V]

The next problem comes up in the compound Wilson-loop estimates of Sec. V, where a vortex can pierce two separated Wilson loops. In  $d = 3$ , consider the plane surface of dimensions  $L_1, L_2$  centered on and perpendicular to the  $z$ -axis at a distance  $M$  along this axis from the origin. We ask for the probabilities  $p_3(N; L_1, L_2, M)$  to end up on this surface after  $N$  steps; the probability  $q_3(N; L_1, L_2, M)$  of reaching this surface for the first time after  $N$  steps; and the probability of ever reaching it. Also to be calculated are the corresponding generating functions  $P_3(s; L_i, M)$  and  $Q_3(s; L_i, M)$ . We assume that all lengths  $L_i, M$  are large in lattice units, so that the number of steps is also large.

The first probability is a sum over the surface of the probability given in Eq. (14):

$$p_3(N; L_i, M) = \sum_{m_i = -L_i/2}^{m_i = L_i/2} p_3(N; \vec{m})|_{m_3 = M}. \quad (\text{A14})$$

The sum is easily done to yield

$$\begin{aligned} p_3(N; L_i, M) &= \frac{1}{(2\pi)^3 3^N} \left[ \prod_{j=1}^3 \int_0^{2\pi} d\theta_j \right] [\cos\theta_1 + \cos\theta_2 \\ &\quad + \cos\theta_3]^N \exp[iM\theta_3] \frac{\sin[(L_1 + 1)\theta_1/2]}{\sin[\theta_1/2]} \\ &\quad \times \frac{\sin[(L_1 + 1)\theta_2/2]}{\sin[\theta_2/2]}. \end{aligned} \quad (\text{A15})$$

In the large- $N$  limit  $N \gg L_i^2$ , one finds an area factor

emerging:

$$p_3(N; L_i, M) \simeq \frac{A}{(2\pi)^3 3^N} \left[ \prod_{j=1}^3 \int_0^{2\pi} d\theta_j \right] [\cos\theta_1 + \cos\theta_2 + \cos\theta_3]^N \exp[iM\theta_3] \quad (\text{A16})$$

where  $A = L_1 L_2$  is the area of the surface. This happens because the integrand is only appreciable when  $\theta_i \leq N^{-1/2}$ . The generating function for this probability, if needed, is constructed as in Eq. (A11), including summing over  $m_1, m_2$ .

The probability  $q_3(N; L_1, L_2, M)$  is determined by an analog of Eq. (A2), including a sum over surface variables:

$$p_3(N; L_i, M) = \sum_J \sum_{m_i} q_3(J; m_i, M) p_3(N - J; m_i, 0) \quad (\text{A17})$$

where the sum over  $m_1, m_2$  is delimited as in Eq. (A14). To see what this sum means, write the  $q$ -probability in Fourier form

$$q_3(J; m_i, M) = \frac{1}{(2\pi)^3} \int d^3\theta \tilde{q}_3(J; \vec{\theta}) e^{i\vec{\theta} \cdot \vec{m}} \quad (\text{A18})$$

with  $m_3 = M$ . We find, using Eq. (14),

$$p_3(N; L_i, M) = \sum_J \int \frac{d^3\theta}{(2\pi)^3} e^{i\theta_3 M} \tilde{q}_3(J; \vec{\theta}) \times \prod_{j=1,2} \frac{\sin[L_j(\theta_j + \alpha_j + 1)/2]}{\sin[(\theta_j + \alpha_j + 1/2)]} \times \int \frac{d^3\alpha}{(2\pi)^3} \left[ \left( \sum \cos\alpha_i \right) / 3 \right]^{N-J}. \quad (\text{A19})$$

We anticipate, and can confirm later, that in the limit  $N \rightarrow \infty$  the  $\theta_j$  are of order  $J^{-1/2}$  and the  $\alpha_j$  are of order  $(N - J)^{-1/2}$ . It turns out that  $N - J$  is large compared to  $J$  (which is of order  $M^2$ ) and so we can drop the  $\alpha_{1,2}$  in the argument of the sine functions in Eq. (A19). The  $\alpha$  integral then factors out, and is given by the probability  $p_3(N - J; \vec{0})$  of returning to a given point after  $N - J$  steps.

The problem is now solved, in principle, by using generating functions, as in Eq. (A9). Or one can study the sum of Eq. (A19) directly, and find by a scaling argument that the maximum value of the  $q$ -probability on the right-hand side behaves like  $A/J \sim A/M^2$ . Note that when lattice lengths  $L_i, M$  are converted to physical lengths by multiplying by  $\lambda$  this probability remains finite.

- 
- [1] M. Engelhardt and H. Reinhardt, Nucl. Phys. **B585**, 591 (2000); M. Engelhardt, M. Quandt, and H. Reinhardt, Nucl. Phys. **B685**, 227 (2004); M. Quandt, H. Reinhardt, and M. Engelhardt, Phys. Rev. D **71**, 054026 (2005).
- [2] J. Greensite, Prog. Part. Nucl. Phys. **51**, 1 (2003).
- [3] J. M. Cornwall, Phys. Rev. D **70**, 065005 (2004).
- [4] L. Del Debbio, M. Faber, J. Giedt, J. Greensite, and Š. Olejník, Phys. Rev. D **58**, 094501 (1998); R. Bertle, M. Faber, J. Greensite, and Š. Olejník, J. High Energy Phys. **10** (2000) 007; M. Faber, J. Greensite, and Š. Olejník, J. High Energy Phys. **11** (2001) 053.
- [5] P. de Forcrand and M. Pepe, Nucl. Phys. **B598**, 557 (2001).
- [6] K. Langfeld, O. Tennert, M. Engelhardt, and H. Reinhardt, Phys. Lett. B **452**, 301 (1999).
- [7] J. M. Cornwall, Phys. Rev. D **69**, 065019 (2004).
- [8] J. M. Cornwall, Phys. Rev. D **69**, 065013 (2004).
- [9] M. Engelhardt, K. Langfeld, H. Reinhardt, and O. Tennert, Phys. Lett. B **431**, 141 (1998).
- [10] A. M. Nemirovsky and M. D. Coutinho-Filho, Phys. Rev. A **39**, 3120 (1989).
- [11] H. N. V. Temperley and M. E. Fisher, Philos. Mag. **6**, 1061 (1961); M. E. Fisher, Phys. Rev. **124**, 1664 (1961); P. W. Kasteleyn, J. Math. Phys. (N.Y.) **4**, 287 (1963).
- [12] E. W. Montroll, J. SIAM **4**, 241 (1956).
- [13] W. Feller, *An Introduction to Probability Theory and its Applications* (Wiley, New York, 1951).
- [14] J. M. Cornwall, *Workshop on Non-Perturbative Quantum Chromodynamics*, edited by K. A. Milton and A. Samuel (Birkhäuser, Boston, 1982), p. 119; Phys. Rev. D **57**, 7589 (1998).
- [15] J. M. Cornwall, Phys. Rev. D **71**, 056002 (2005).
- [16] M. Lüscher, Nucl. Phys. **B180**, 317 (1981); M. Lüscher, K. Symanzik, and P. Weisz, Nucl. Phys. **B173**, 365 (1980).
- [17] T. T. Takahashi, H. Matsufuru, Y. Nemoto, and H. Suganuma, Phys. Rev. Lett. **86**, 18 (2001); Phys. Rev. D **65**, 114509 (2002).
- [18] C. Alexandrou, P. de Forcrand, and O. Jahn, Nucl. Phys. B, Proc. Suppl. **119**, 667 (2003).
- [19] M. Engelhardt, Phys. Rev. D **70**, 074004 (2004).