

Lattice extraction of $K \rightarrow \pi\pi$ amplitudes to next-to-leading order in partially quenched and in full chiral perturbation theory

Jack Laiho*

Department of Physics, Princeton University, Princeton, New Jersey 08544, USA

Amarjit Soni†

Theory Group, Brookhaven National Laboratory, Upton, New York 11973, USA

(Received 3 September 2003; revised manuscript received 16 July 2004; published 19 January 2005)

We show that it is possible to construct ϵ'/ϵ to next-to-leading order (NLO) using partially quenched chiral perturbation theory (PQChPT) from amplitudes that are computable on the lattice. We demonstrate that none of the needed amplitudes require 3-momentum on the lattice for either the full theory or the partially quenched theory; nondegenerate quark masses suffice. Furthermore, we find that the electro-weak penguin ($\Delta I = 3/2$ and $1/2$) contributions to ϵ'/ϵ in PQChPT can be determined to NLO using only degenerate ($m_K = m_\pi$) $K \rightarrow \pi$ computations without momentum insertion. Issues pertaining to power divergent contributions, originating from mixing with lower dimensional operators, are addressed. Direct calculations of $K \rightarrow \pi\pi$ at unphysical kinematics are plagued with enhanced finite volume effects in the (partially) quenched theory, but in simulations when the sea quark mass is equal to the up and down quark mass the enhanced finite volume effects vanish to NLO in PQChPT. In embedding the QCD penguin left-right operator onto PQChPT an ambiguity arises, as first emphasized by Golterman and Pallante. With one version [the ‘‘PQS’’ (partially quenched singlet)] of the QCD penguin, the inputs needed from the lattice for constructing $K \rightarrow \pi\pi$ at NLO in PQChPT coincide with those needed for the full theory. Explicit expressions for the finite logarithms emerging from our NLO analysis to the above amplitudes also are given.

DOI: 10.1103/PhysRevD.71.014021

PACS numbers: 12.39.Fe, 12.38.Gc

I. INTRODUCTION

There have been several recent lattice attempts to calculate $\text{Re}(\epsilon'/\epsilon)$, the direct CP violating parameter in $K \rightarrow \pi\pi$ decays. These include attempts with domain wall fermions by the CP-PACS [1] and RBC [2] collaborations. A notable feature of both of these calculations is that their central values differ drastically from experiment. The experiments at CERN [3] and Fermilab [4] have yielded an experimental grand average of $\text{Re}(\epsilon'/\epsilon) = (1.8 \pm 0.4) \times 10^{-3}$ [5]. The lattice collaborations find a value $\sim -0.5 \times 10^{-3}$, a *negative* value, though the groups have made rather severe approximations. Such a disagreement between theory and experiment should not be totally unexpected given the serious approximations and resulting systematic errors, which have so far been necessary in order to implement the calculation on the lattice [6,7].

One of these uncontrolled approximations was the use of the quenched approximation, where the fermion determinant in the path integral is set to a constant in order to make the problem more tractable on present day computers. Another was the use of leading order chiral perturbation theory to relate unphysical $K \rightarrow \pi$ and $K \rightarrow 0$ amplitudes to the physical $K \rightarrow \pi\pi$ amplitudes, as first proposed by [8]. Because of the difficulty of extracting multihadron

decay amplitudes from the lattice, as expressed by the Maiani-Testa theorem [9], it is much easier to compute the two- and three-point functions (i.e., $K \rightarrow 0$ and $K \rightarrow \pi$, respectively) and use ChPT to extrapolate to the physical matrix elements.

It is likely that the next-to-leading order (NLO) corrections to ChPT will be significant for the operators that contribute to $\text{Re}(\epsilon'/\epsilon)$ and should not be neglected. Unfortunately, at higher orders in ChPT the number of free parameters that must be determined from first-principles methods like the lattice proliferates rapidly. It has been shown by Cirigliano and Golowich [10] that the dominant electro-weak penguin contributions [(8,8)'s] to $K \rightarrow \pi\pi$ can be recovered at NLO from $K \rightarrow \pi$ amplitudes using 4-momentum insertion. Bijens, *et al.* [11] showed how to obtain most of the low-energy constants (LEC's) relevant for the case of the (8,1)'s and (27,1)'s using off shell $K \rightarrow \pi$ Green's functions; not all LEC's could be determined using this method, though.

In [12], it was shown how to obtain physical $K \rightarrow \pi\pi$, $\Delta I = 3/2$ [(27,1)'s and (8,8)'s] at NLO from $K \rightarrow \pi\pi$ at unphysical (SPQcdR) kinematics accessible to the lattice. This method requires 3-momentum insertion, and it is not yet clear if it can be extended to the $\Delta I = 1/2$, $K \rightarrow \pi\pi$ amplitudes. In our previous paper [13], an alternative method was proposed for constructing the physical $K \rightarrow \pi\pi$ amplitudes to NLO for all ($\Delta I = 1/2$ and $3/2$) operators of interest. For the $\Delta I = 3/2$ amplitudes this requires

*Electronic address: jlaiho@princeton.edu

†Electronic address: soni@bnl.gov

$K \rightarrow \bar{K}$; $K \rightarrow \pi$, $\Delta I = 3/2$; and $K \rightarrow \pi\pi$, $\Delta I = 3/2$ at one of (at least) two unphysical kinematics points where the Maiani-Testa theorem can be bypassed. The two special kinematics points where this is possible have been discussed in the literature: (i) $m_K^{\text{lat}} = m_\pi^{\text{lat}}$, where the weak operator inserts energy [14]; and (ii) $m_K^{\text{lat}} = 2m_\pi^{\text{lat}}$, i.e., at threshold [15]. As in [13], we refer to these two cases as unphysical kinematics point one (UK1) and point two (UK2), respectively. Finally, it was shown also in [13] how to obtain the physical $K \rightarrow \pi\pi$ at NLO for the $\Delta I = 1/2$, (8,1) (e.g., Q_4 and Q_6) and the mixed (27, 1) \oplus (8, 1) case (e.g., Q_2) using $K \rightarrow \pi$ with 4-momentum insertion and $K \rightarrow \pi\pi$ at both UK1 and UK2. Note that the mixed case also requires information obtainable from the amplitudes needed to get $K \rightarrow \pi\pi$, $\Delta I = 3/2$ for the (27,1)'s. The main purpose of [13] was, in fact, to show that even for the (8,1)'s all of the information needed to construct $K \rightarrow \pi\pi$ to NLO in ChPT could be obtained from amplitudes that can be computed on the lattice, at least in principle.

There are other unphysical kinematics values for the $K \rightarrow \pi\pi$ amplitudes where the initial and final state mesons are at rest that bypass the Maiani-Testa theorem. These kinematics are similar to UK1 in that they require energy insertion, but with $m_K \neq m_\pi$. We call this set of kinematics UKX. This corresponds to the SPQcdR kinematics with both pions at rest [12]. Lattice calculations at these values of the kinematics are important given that the calculation at UK1 has difficulties [16] and also given that it will be important to determine the NLO LEC's in as many ways as possible for additional redundancy. Even if it is difficult or impossible to obtain the necessary NLO low-energy constants for the (8,1)'s at UK1, one can obtain the same information using UKX. Thus, all information for the (8,1)'s can be determined to NLO without using UK1, the difficulties of which are discussed in Sec. VIII and in the note added in revision. Results at UKX are given also in Sec. VIII.

In this work we show that where 4-momentum insertion is required for any of the amplitudes needed according to the prescription of [13], it suffices to allow only energy insertion at the weak operator such that the initial and final state mesons are at rest. This means that the $K \rightarrow \pi\pi$ amplitudes can be constructed to NLO using nondegenerate quarks, but without using 3-momentum insertion, making the computation much more economical.

Another approach to $K \rightarrow \pi\pi$ and ϵ'/ϵ amplitudes has been proposed by Lellouch and Luscher [17] in which finite volume correlation functions on the lattice are used to extract physical amplitudes without recourse to ChPT, at least in principle. This method is expected to be difficult computationally, but a way of reducing the cost of the Lellouch-Luscher method has been proposed [18]. An alternative method to obtain $K \rightarrow \pi\pi$ amplitudes to all orders in ChPT has been proposed by [19]; this proposal makes use of dispersion relations. Both of the above

methods depend crucially on unitarity, so it is unclear if they can be implemented with partially quenched lattice simulations.

Although NLO ChPT may not be the final answer, it is more reliable than leading order, and it is useful to have the NLO expressions even to extract the leading order LEC's from the lattice data. Since the lattice data that will be generated in the near term will be in the (partially) quenched approximation, it is necessary to have the corresponding amplitudes in partially quenched ChPT. Therefore, in this paper, we present the partially quenched expressions for the quantities of greatest interest for $\text{Re}(\epsilon'/\epsilon)$, namely, the amplitudes for the (8,1) and (8,8) operators. For the partially quenched amplitudes we assume that all relevant quark masses are small compared to the η' mass, so that the η' can be integrated out, and the LEC's of the partially quenched theory coincide with those of the full theory when the number of sea quarks is three [20].

For the $\Delta I = 1/2$ amplitudes there is an additional complication involving eye diagrams having to do with the sum over quarks in the penguin operators [21]. For the left-right gluonic penguin operators the two possible choices correspond to what we will call the PQS (partially quenched singlet) method and the PQN (partially quenched nonsinglet) method. They are discussed in detail in Sec. VIA. It is important to note that only for the PQS method can the LEC's sufficient to construct ϵ'/ϵ to NLO be determined, whereas it is not clear if the PQN method can be extended to NLO. Indeed, a significant advantage of the PQS implementation is that the ingredients needed from the lattice to obtain all $K \rightarrow \pi\pi$ amplitudes to NLO in PQChPT are the same as in the full theory. Therefore, the PQS method is used to compute the NLO amplitudes in this paper. Finally, it should be mentioned that the $\Delta I = 1/2$, $K \rightarrow \pi\pi$ amplitudes receive enhanced finite volume contributions in the partially quenched theory [22,23]. However, when $m_{\text{sea}} = m_u = m_d$, the infrared divergences in the $K \rightarrow \pi\pi$ amplitudes (at UK1 and UK2) vanish in PQChPT in the infinite volume Minkowski space amplitudes. In an earlier version of this paper we had pointed out that it would be important to study the finite volume effects of these amplitudes; the corresponding finite volume Euclidian Green's functions were calculated by [16] while this work was in revision.¹

In the partially quenched theory, it is possible to construct the (8,8) $K \rightarrow \pi\pi$ amplitudes to NLO using only degenerate valence quark masses in $K \rightarrow \pi$, along with $K \rightarrow 0$ in order to perform the power divergent subtraction in the $\Delta I = 1/2$ case. Additional redundancy is possible if

¹Reference [16] found that the infrared problems do not vanish for UK1 finite volume Euclidean correlation functions in the partially quenched theory; for further details, see our note added in revision.

one uses nondegenerate valence quark masses in the $K \rightarrow \pi$ calculation.

The content of the paper is as follows: Section II briefly reviews the formalism of effective four-fermion operators in a standard model calculation. Section III reviews ChPT and the realization of the effective four-quark operators in terms of ChPT operators for weak processes. Section IV reviews partially quenched chiral perturbation theory and how it can be extended to the electro-weak sector. Section V presents results for the full theory, demonstrating that for all the amplitudes considered in [13], 3-momentum insertion is not essential and nondegenerate quark masses suffices to construct $K \rightarrow \pi\pi$ to NLO. In Sec. VI a discussion of the treatment of eye diagrams in the partially quenched theory is given, as well as a comparison of PQS and PQN results at leading order according to the papers by Golterman and Pallante [21]. Sections VII and VIII present the main results of this paper, showing how to obtain the $K \rightarrow \pi\pi$ amplitudes needed for $\text{Re}(\epsilon'/\epsilon)$ in the partially quenched theory from quantities which can be computed directly on the lattice. Section VII deals with the (8,8) amplitudes, while Section VIII deals with the (8,1)'s. Section IX discusses the checks done on the various one-loop logarithmic expressions. Section X presents the conclusion. The finite logarithm contributions to the relevant amplitudes are presented in a set of appendices. Errors in Eqs. (31, D6) of [13] are corrected in Appendix F.

II. EFFECTIVE FOUR-QUARK OPERATORS

In the standard model, the nonleptonic interactions can be expressed in terms of an effective $\Delta S = 1$ Hamiltonian using the operator product expansion [24,25],

$$\langle \pi\pi | \mathcal{H}_{\Delta S=1} | K \rangle = \frac{G_F}{\sqrt{2}} \sum V_{\text{CKM}}^i c_i(\mu) \langle \pi\pi | Q_i | K \rangle_\mu, \quad (1)$$

where V_{CKM}^i are the relevant combinations of Cabibbo-Kobayashi-Maskawa quark-mixing matrix (CKM) elements, $c_i(\mu)$ are the Wilson coefficients containing the short distance perturbative physics, and the matrix elements $\langle \pi\pi | Q_i | K \rangle_\mu$ must be calculated nonperturbatively. The four-quark operators are

$$Q_1 = \bar{s}_a \gamma_\mu (1 - \gamma^5) d_a \bar{u}_b \gamma^\mu (1 - \gamma^5) u_b, \quad (2)$$

$$Q_2 = \bar{s}_a \gamma_\mu (1 - \gamma^5) d_b \bar{u}_b \gamma^\mu (1 - \gamma^5) u_a, \quad (3)$$

$$Q_3 = \bar{s}_a \gamma_\mu (1 - \gamma^5) d_a \sum_q \bar{q}_b \gamma^\mu (1 - \gamma^5) q_b, \quad (4)$$

$$Q_4 = \bar{s}_a \gamma_\mu (1 - \gamma^5) d_b \sum_q \bar{q}_b \gamma^\mu (1 - \gamma^5) q_a, \quad (5)$$

$$Q_5 = \bar{s}_a \gamma_\mu (1 - \gamma^5) d_a \sum_q \bar{q}_b \gamma^\mu (1 + \gamma^5) q_b, \quad (6)$$

$$Q_6 = \bar{s}_a \gamma_\mu (1 - \gamma^5) d_b \sum_q \bar{q}_b \gamma^\mu (1 + \gamma^5) q_a, \quad (7)$$

$$Q_7 = \frac{3}{2} \bar{s}_a \gamma_\mu (1 - \gamma^5) d_a \sum_q e_q \bar{q}_b \gamma^\mu (1 + \gamma^5) q_b, \quad (8)$$

$$Q_8 = \frac{3}{2} \bar{s}_a \gamma_\mu (1 - \gamma^5) d_b \sum_q e_q \bar{q}_b \gamma^\mu (1 + \gamma^5) q_a, \quad (9)$$

$$Q_9 = \frac{3}{2} \bar{s}_a \gamma_\mu (1 - \gamma^5) d_a \sum_q e_q \bar{q}_b \gamma^\mu (1 - \gamma^5) q_b, \quad (10)$$

$$Q_{10} = \frac{3}{2} \bar{s}_a \gamma_\mu (1 - \gamma^5) d_b \sum_q e_q \bar{q}_b \gamma^\mu (1 - \gamma^5) q_a. \quad (11)$$

In the effective theory Q_1 and Q_2 are the current-current weak operators, $Q_3 - Q_6$ are the operators arising from QCD penguin diagrams, while $Q_7 - Q_{10}$ are the operators arising from electro-weak penguin diagrams. Note that the definitions of Q_1 and Q_2 are different from our previous paper [13]. After a Fierz transformation, one can see that the definitions of the two operators are switched. We have changed the definitions of Q_1 and Q_2 to be consistent with the basis used by RBC [2] and that of [24]; this does not, of course, effect any of the results of our previous paper.

III. CHIRAL PERTURBATION THEORY

Chiral perturbation theory is an effective quantum field theory where the quark and gluon degrees of freedom have been integrated out, and is expressed only in terms of the lowest mass pseudoscalar mesons [26]. It is a perturbative expansion about small quark masses and small momentum of the low mass pseudoscalars. The effective Lagrangian is made up of complicated nonlinear functions of the pseudoscalar fields, and is nonrenormalizable, making it necessary to introduce arbitrary constants at each order in perturbation theory. In such an expansion, operators of higher order in the momentum (terms with increasing numbers of derivatives) or mass appear at higher order in the perturbative expansion. The most general set of operators at a given order can be constructed out of the unitary chiral matrix field Σ , given by

$$\Sigma = \exp\left[\frac{2i\phi^a \lambda^a}{f}\right], \quad (12)$$

where λ^a are proportional to the Gell-Mann matrices with $\text{tr}(\lambda_a \lambda_b) = \delta_{ab}$, ϕ^a are the real pseudoscalar-meson fields, and f is the meson decay constant in the chiral limit, with f_π equal to 130 MeV in our convention.

At leading order [$O(p^2)$] in ChPT, the strong Lagrangian is given by

$$\mathcal{L}_{st}^{(2)} = \frac{f^2}{8} \text{tr}[\partial_\mu \Sigma \partial^\mu \Sigma] + \frac{f^2 B_0}{4} \text{tr}[\chi^\dagger \Sigma + \Sigma^\dagger \chi], \quad (13)$$

where $\chi = (m_u, m_d, m_s)_{\text{diag}}$ and

$$B_0 = \frac{m_{\pi^+}^2}{m_u + m_d} = \frac{m_{K^+}^2}{m_u + m_s} = \frac{m_{K^0}^2}{m_d + m_s}.$$

The leading order weak chiral Lagrangian is given by [8,10]

$$\begin{aligned} \mathcal{L}_W^{(2)} = & \alpha_{88} \text{tr}[\lambda_6 \Sigma Q \Sigma^\dagger] + \alpha_1 \text{tr}[\lambda_6 \partial_\mu \Sigma \partial^\mu \Sigma^\dagger] \\ & + \alpha_2 2B_0 \text{tr}[\lambda_6 (\chi^\dagger \Sigma + \Sigma^\dagger \chi)] \\ & + \alpha_{27} t_{kl}^{ij} (\Sigma \partial_\mu \Sigma^\dagger)_i^k (\Sigma \partial^\mu \Sigma^\dagger)_j^l + \text{H.c.}, \end{aligned} \quad (14)$$

where t_{kl}^{ij} is symmetric in i, j and k, l , traceless on any pair of upper and lower indices with nonzero elements $t_{12}^{13} = 1$, $t_{22}^{23} = 1/2$, and $t_{32}^{33} = -3/2$. Also, Q is the quark charge matrix, $Q = 1/3(2, -1, -1)_{\text{diag}}$ and $(\lambda_6)_{ij} = \delta_{i3} \delta_{j2}$. The reason λ_6 enters these expressions is because it picks out the s to d , $\Delta S = 1$ transition.

The terms in the weak Lagrangian can be classified according to their chiral transformation properties under $SU(3)_L \times SU(3)_R$. The first term in (14) transforms as $8_L \times 8_R$ under chiral rotations and corresponds to the electro-weak penguin operators Q_7 and Q_8 . The next two terms in (14) transform as $8_L \times 1_R$, while the last transforms as $27_L \times 1_R$ under chiral rotations. All ten of the four-quark operators of the effective weak Lagrangian have a realization in the chiral Lagrangian differing only in their transformation properties and the values of the low-energy

constants which contain the nonperturbative dynamics of the theory.

For the transition of interest, $K \rightarrow \pi\pi$, the operators can induce a change in isospin of $\frac{1}{2}$ or $\frac{3}{2}$ leading to a final isospin state of the pions of 0 or 2, respectively. We can then classify the isospin components of the four-quark operators according to their transformation properties [1,2]:

$$Q_1^{1/2}, Q_2^{1/2}, Q_9^{1/2}, Q_{10}^{1/2}: 8_L \times 1_R \oplus 27_L \times 1_R;$$

$$Q_1^{3/2}, Q_2^{3/2}, Q_9^{3/2}, Q_{10}^{3/2}: 27_L \times 1_R;$$

$$Q_3^{1/2}, Q_4^{1/2}, Q_5^{1/2}, Q_6^{1/2}: 8_L \times 1_R;$$

$$Q_7^{1/2}, Q_8^{1/2}, Q_7^{3/2}, Q_8^{3/2}: 8_L \times 8_R.$$

Note that Q_3 – Q_6 are pure isospin $\frac{1}{2}$ operators. At NLO the strong Lagrangian involves 12 additional operators with undetermined coefficients. These were introduced by Gasser and Leutwyler in [27]. The complete basis of counterterm operators for the weak interactions with $\Delta S = 1, 2$ was treated by Kambor, Missimer, and Wyler in [28,29]. A minimal set of counterterm operators contributing to $K \rightarrow \pi$ and $K \rightarrow \pi\pi$ for the $(8_L, 1_R)$ and $(27_L, 1_R)$ cases is given by [30], with the effective Lagrangian

$$\mathcal{L}_W^{(\text{NLO})} = \sum e_i \mathcal{O}_i^{(8,1)} + \sum d_i \mathcal{O}_i^{(27,1)} + \sum c_i \mathcal{O}_i^{(8,8)}, \quad (15)$$

$$\begin{aligned} \mathcal{O}_1^{(8,1)} &= \text{tr}[\lambda_6 S^2], & \mathcal{O}_2^{(8,1)} &= \text{tr}[\lambda_6 S] \text{tr}[S], & \mathcal{O}_3^{(8,1)} &= \text{tr}[\lambda_6 P^2], & \mathcal{O}_4^{(8,1)} &= \text{tr}[\lambda_6 P] \text{tr}[P], \\ \mathcal{O}_5^{(8,1)} &= \text{tr}[\lambda_6 \{S, P\}], & \mathcal{O}_{10}^{(8,1)} &= \text{tr}[\lambda_6 \{S, L^2\}], & \mathcal{O}_{11}^{(8,1)} &= \text{tr}[\lambda_6 L_\mu S L^\mu], & \mathcal{O}_{12}^{(8,1)} &= \text{tr}[\lambda_6 L_\mu] \text{tr}[\{L^\mu, S\}], \\ \mathcal{O}_{13}^{(8,1)} &= \text{tr}[\lambda_6 S][L^2], & \mathcal{O}_{15}^{(8,1)} &= \text{tr}[\lambda_6 \{P, L^2\}], & \mathcal{O}_{35}^{(8,1)} &= \text{tr}[\lambda_6 \{L_\mu, \partial_\nu W^{\mu\nu}\}], & \mathcal{O}_{39}^{(8,1)} &= \text{tr}[\lambda_6 W_{\mu\nu} W^{\mu\nu}], \\ \mathcal{O}_1^{(8,8)} &= \text{tr}[\lambda_6 L_\mu \Sigma^\dagger Q \Sigma L^\mu], & \mathcal{O}_2^{(8,8)} &= \text{tr}[\lambda_6 L_\mu] \text{tr}[\Sigma^\dagger Q \Sigma L^\mu], & \mathcal{O}_3^{(8,8)} &= \text{tr}[\lambda_6 \{\Sigma^\dagger Q \Sigma, L^2\}], \\ \mathcal{O}_4^{(8,8)} &= \text{tr}[\lambda_6 \{\Sigma^\dagger Q \Sigma, S\}], & \mathcal{O}_5^{(8,8)} &= \text{tr}[\lambda_6 \{\Sigma^\dagger Q \Sigma, P\}], & \mathcal{O}_6^{(8,8)} &= \text{tr}[\lambda_6 \Sigma^\dagger Q \Sigma] \text{tr}[S], & \mathcal{O}_1^{(27,1)} &= t_{kl}^{ij} (S)_i^k (S)_j^l, \\ \mathcal{O}_2^{(27,1)} &= t_{kl}^{ij} (P)_i^k (P)_j^l, & \mathcal{O}_4^{(27,1)} &= t_{kl}^{ij} (L_\mu)_i^k (\{L^\mu, S\})_j^l, & \mathcal{O}_5^{(27,1)} &= t_{kl}^{ij} (L_\mu)_i^k ([L^\mu P])_j^l, & \mathcal{O}_6^{(27,1)} &= t_{kl}^{ij} (S)_i^k (L^2)_j^l, \\ \mathcal{O}_7^{(27,1)} &= t_{kl}^{ij} (L_\mu)_i^k (L^\mu)_j^l \text{tr}[S], & \mathcal{O}_{20}^{(27,1)} &= t_{kl}^{ij} (L_\mu)_i^k (\partial_\nu W^{\mu\nu})_j^l, & \mathcal{O}_{24}^{(27,1)} &= t_{kl}^{ij} (W_{\mu\nu})_i^k (W^{\mu\nu})_j^l, \end{aligned} \quad (16)$$

with $S = 2B_0(\chi^\dagger \Sigma + \Sigma^\dagger \chi)$, $P = 2B_0(\chi^\dagger \Sigma - \Sigma^\dagger \chi)$, $L_\mu = i\Sigma^\dagger \partial_\mu \Sigma$, and $W^{\mu\nu} = 2(\partial_\mu L_\nu - \partial_\nu L_\mu)$.

This list is identical to that of Bijnens *et al.* [11] for the $(27,1)$'s and the $(8,1)$'s, except for the inclusion of $\mathcal{O}_{35,39}^{(8,1)}$ and $\mathcal{O}_{20,24}^{(27,1)}$ which contain surface terms and so cannot be absorbed into the other constants for processes which do not conserve 4-momentum at the weak vertex. Since we must use 4-momentum insertion in a number of our amplitudes, these counterterms must be considered, and they are left explicit even in the physical amplitudes. The list of $(8,8)$ operators is that of Cirigliano and Golowich [10].

The divergences associated with the counterterms have been obtained in [10,11,28]. The subtraction procedure can be defined as

$$\begin{aligned} e_i = & e_i^r + \frac{1}{16\pi^2 f^2} \left[\frac{1}{d-4} + \frac{1}{2}(\gamma_E - 1 - \ln 4\pi) \right] 2(\alpha_1 \varepsilon_i \\ & + \alpha_2 \varepsilon_i'), \end{aligned} \quad (17)$$

$$d_i = d_i^r + \frac{1}{16\pi^2 f^2} \left[\frac{1}{d-4} + \frac{1}{2}(\gamma_E - 1 - \ln 4\pi) \right] 2\alpha_{27} \gamma_i, \quad (18)$$

TABLE I. The divergences in the weak $O(p^4)$ counterterms, e_i 's and d_i 's, for the (8,1)'s and (27,1)'s, respectively, and the divergences in the weak $O(p^2)$ counterterms, the c_i 's for the (8,8)'s.

e_i	ε_i	ε'_i	d_i	γ_i	c_i	η_i
1	1/4	5/6	1	-1/6	1	0
2	-13/18	11/18	2	0	2	-2
3	5/12	0	4	3	3	-3/2
4	-5/36	0	5	1	4	3/2
5	0	5/12	6	-3/2	5	0
10	19/24	3/4	7	1	6	1
11	3/4	0	20	1/2		
12	1/8	0	24	1/8		
13	-7/8	1/2				
15	23/24	-3/4				
35	-3/8	0				
39	-3/16	0				

$$c_i = c_i^r + \frac{1}{16\pi^2 f^2} \left[\frac{1}{d-4} + \frac{1}{2}(\gamma_E - 1 - \ln 4\pi) \right] 2\alpha_{88} \eta_i, \quad (19)$$

with the divergent pieces, ε_i , ε'_i , γ_i , η_i given in Table I.

It is also necessary for the method of this paper to consider the $O(p^4)$ strong Lagrangian, which was first given by Gasser and Leutwyler, $\mathcal{L}_{\text{st}}^{(4)} = \sum L_i \mathcal{O}_i^{(\text{st})}$.

The strong $O(p^4)$ operators relevant for this calculation are the following [27]:

$$\begin{aligned} \mathcal{O}_1^{(\text{st})} &= \text{tr}[L^2]^2, & \mathcal{O}_2^{(\text{st})} &= \text{tr}[L_\mu L_\nu] \text{tr}[L^\mu L^\nu], \\ \mathcal{O}_3^{(\text{st})} &= \text{tr}[L^2 L^2], & \mathcal{O}_4^{(\text{st})} &= \text{tr}[L^2] \text{tr}[S], \\ \mathcal{O}_5^{(\text{st})} &= \text{tr}[L^2 S], & \mathcal{O}_6^{(\text{st})} &= \text{tr}[S]^2, \\ \mathcal{O}_8^{(\text{st})} &= \frac{1}{2} \text{tr}[S^2 - P^2]. \end{aligned} \quad (20)$$

The Gasser-Leutwyler counterterms also contribute to the cancellation of divergences in the expressions relevant to this paper. The subtraction is defined similarly to that of the weak counterterms,

TABLE II. The divergences in the strong $O(p^4)$ counterterms, Γ_i [27].

i	Γ_i
1	3/32
2	3/16
3	0
4	1/8
5	3/8
6	11/144
8	5/48

$$L_i = L_i^r + \frac{1}{16\pi^2} \left[\frac{1}{d-4} + \frac{1}{2}(\gamma_E - 1 - \ln 4\pi) \right] \Gamma_i, \quad (21)$$

with the divergent parts of the counterterm coefficients given in Table II [27].

IV. PARTIALLY QUENCHED CHIRAL PERTURBATION THEORY

There are two approaches to (partially) quenched QCD, the supersymmetric formulation [31] and the replica method [32]. Damgaard and Splittorff claim that the two methods are equivalent in the context of perturbation theory in the strong sector. We choose to follow the original method of Bernard and Golterman [31] for partially quenched chiral perturbation theory (PQChPT). In this method, the valence quarks are quenched by introducing ‘‘ghost’’ quarks which have the same mass and quantum numbers as the valence quarks but opposite statistics. As in [30], we consider a theory with n quarks and N sea quarks, so that there are $n - N$ valence and $n - N$ ghost quarks. The valence quarks have arbitrary mass, while the sea quarks are all degenerate. The symmetry group of the action is $\text{SU}(n|n - N)_L \otimes \text{SU}(n|n - N)_R$.

In the partially quenched case, the chiral field

$$\Sigma = \exp \left[\frac{2i\phi^a \lambda^a}{f} \right], \quad (22)$$

has $\phi^a \lambda^a$ replaced by a $(2n - N) \times (2n - N)$ matrix,

$$\Phi \equiv \begin{pmatrix} \phi & \chi^\dagger \\ \chi & \tilde{\phi} \end{pmatrix}, \quad (23)$$

where ϕ is a $n \times n$ matrix containing the pseudoscalar-meson fields comprised of normal valence and sea quarks. $\tilde{\phi}$ is a $(n - N) \times (n - N)$ matrix comprised of ghost-antighost quarks, while χ^\dagger is an $n \times (n - N)$ matrix of Goldstone fermions comprised of quarks and antighosts. The most general set of operators can be constructed out of Σ , and these operators can be written in block form as

$$U = \begin{pmatrix} A & B \\ C & D \end{pmatrix}, \quad (24)$$

where the submatrices have the same dimension as the elements of Φ , above. The transition to the partially quenched theory is made by replacing $\phi^a \lambda^a$ by the above $(2n - N) \times (2n - N)$ matrix, Φ , and replacing the traces in the operators with supertraces, defined as

$$\text{str}(U) = \text{tr}(A) - \text{tr}(D). \quad (25)$$

As a practical matter, in almost all of the NLO diagram calculations considered in this paper, the minus sign in the

supertrace is cancelled by an additional minus sign coming from anticommuting pseudofermion fields. The bare mass of a pseudoscalar meson is given by

$$m_{ij}^2 = B_0(m_i + m_j), \quad (26)$$

where m_i and m_j are the masses of the two quarks that form the meson. We define m_{33} to be the tree-level meson mass of two valence strange quarks, as in [30]

$$m_{33}^2 = 2m_K^2 - m_\pi^2. \quad (27)$$

The tree-level mass of a meson made from the i th valence quark and a sea quark is

$$m_{iS}^2 = B_0(m_i + m_S) = \frac{1}{2}(m_{ii}^2 + m_{SS}^2), \quad i = u, d, s. \quad (28)$$

In this paper we consider only the case where the η' has been integrated out. Thus, the results are applicable to lattice calculations only when both sea and valence quark masses are small compared to $m_{\eta'}$. Although it may be difficult computationally, this is precisely the case in which the LEC's of PQChPT are the same as those of full QCD when the number of sea quarks is three [20]. This is because the LEC's are independent of quark mass even if one varies sea and valence masses separately. In order that the LEC's of PQChPT be those of the real world, the sea and valence quarks must be small enough that the η' decouples, and its effects are integrated out the same way in both PQChPT and in full ChPT.

The Minkowski space propagators for the flavor diagonal elements of Φ are given by analytically continuing the Euclidean expression in [30]

$$\Delta_{ij} = \frac{\delta_{ij}\epsilon_i}{p^2 - m_{ii}^2 + i\epsilon} - \frac{1}{N} \left(\frac{1}{p^2 - m_{ii}^2 + i\epsilon} + \frac{m_{jj}^2 - m_{SS}^2}{(p^2 - m_{ii}^2 + i\epsilon)(p^2 - m_{jj}^2 + i\epsilon)} \right), \quad (29)$$

where

$$\epsilon_i = \begin{cases} +1, & \text{for } 1 \leq i \leq n(\text{valence and sea}); \\ -1, & \text{for } n+1 \leq i \leq 2n - N(\text{ghost}). \end{cases} \quad (30)$$

At LO (NLO), the operators in PQChPT are still given by Eqs. (13) and (14) [Eqs. (16) and (20)], but with $\text{tr} \rightarrow \text{str}$ for all operators. In the extension to the partially quenched case,

$$\lambda_6 \rightarrow \begin{pmatrix} \lambda_6 & 0 \\ 0 & 0 \end{pmatrix}, \quad (31)$$

in block diagonal form, and the mass matrix,

$$\chi \rightarrow \text{diag}(m_u, m_d, m_s, m_{\text{sea}}, \dots, m_u, m_d, m_s). \quad (32)$$

There is a choice in how to embed the quark charge matrix in the partially quenched theory and this will affect the $\Delta I = 1/2$, (8,8) amplitudes considered in this paper. If one wants to partially quench the electro-weak penguin operators, then the ghost quark charges should be the same as the corresponding valence quark charges. If, on the other hand, one wants to allow valence quarks to couple to photons and Z 's, then the ghost quark charges should be set to zero so they do not appear in, and therefore cancel, the electro-weak valence quark loops. We present amplitudes in this paper for both choices. Also, since we choose the sea quarks to have degenerate mass, the sum of the sea quark charges is the only quantity involving the sea quark charge that contributes. This is zero for three flavors, and in this paper we keep this true for arbitrary sea quark number N by setting the sea quark charge to zero.

Also in the partially quenched case, the coefficient of the counterterm divergence depends on the number of sea quarks, N [23]. The N dependence of the necessary coefficients for the (8,1)'s was calculated following [28,33], and the results are presented in Table III. This paper uses a different basis from [23] for the (8,1)'s, and also several more LEC's appear here, so the calculation was redone for this work. The usual method was employed, expanding the action around the classical solution (background field method) and using a heat kernel expansion. The N dependence of the coefficients of the divergent parts of the (8,8) counterterms was given in [10]. These values are also presented in Table III.

It is necessary to include an additional (8,1) operator, $\mathcal{O}_{14}^{(8,1)} = \text{str}[\lambda_6 L^2] \text{str}[S]$, in this analysis of the partially quenched case since it can no longer be written as a linear combination of the other operators via the Cayley-Hamilton theorem. In the case of full ChPT, the operator $\mathcal{O}_{14}^{(8,1)}$ is absorbed into the other operators, $\mathcal{O}_{10}^{(8,1)}$, $\mathcal{O}_{11}^{(8,1)}$, $\mathcal{O}_{12}^{(8,1)}$, and $\mathcal{O}_{13}^{(8,1)}$. Since e_{14} has a divergent part, the coefficients of the divergences of the other four operators are

TABLE III. The N dependence of the divergences in the NLO counterterms, e_i 's and c_i 's for the (8,1)'s and (8,8)'s, respectively.

e_i	ϵ_i	ϵ'_i	c_i	η_i
1	$-N/4 + 3/N$	$N/2 - 2/N$	1	0
2	$-1/2 - 2/N^2$	$1/2 + 1/N^2$	2	-2
3	$N/4 - 1/N$	0	3	$-N/2$
5	0	$N/4 - 1/N$	4	$N/2$
10	$N/8 + 1/(2N)$	$N/4$	5	0
11	$N/2 - 3/N$	0	6	1
13	$-3/4$	$1/2$		
14	$1/4$	0		
15	$3N/8 - 1/(2N)$	$-N/4$		
35	$-N/8$	0		
39	$-N/16$	0		

TABLE IV. N dependence of the divergences in the strong $O(p^4)$ counterterms, Γ_i [23].

i	Γ_i
1	$1/16 + N/96$
2	$1/8 + N/48$
3	0
4	$1/8$
5	$N/8$
6	$1/16 + 1/(8N^2)$
8	$N/16 - 1/(4N)$

modified (for $N = 3$) from the values in Table I. Note that e_4 and e_{12} have been omitted in Table III. These LEC's do not appear in any of the amplitudes of interest in this paper.

The Gasser-Leutwyler counterterms also contribute to the cancellation of divergences in this paper in the partially quenched case. The N dependence of the coefficients Γ_i is given in Table IV.

When N is arbitrary, there is in general another operator [27] $\text{tr}[L_\mu L_\nu L^\mu L^\nu]$ which cannot be absorbed into the first three Gasser-Leutwyler operators as it can for $N = 3$ using trace relations. For the purposes of this paper, the additional operator and its divergent coefficient, L_0 , can be absorbed into L_1 through L_3 for the only amplitudes of interest to which it contributes, $K \rightarrow \pi\pi$ for $m_K = m_\pi$, and in general, for UKX. Thus, we absorb the N dependence of L_0 into L_1 , L_2 , and L_3 in Table IV.

A. Role of the bilinear $(3, \bar{3})$ operator

The bilinear $(3, \bar{3})$ operator is useful in removing the power divergent coefficients to all orders in ChPT. Recall that the $\Delta I = 1/2$ matrix elements of the four-quark operators in general have a power divergent part. This power divergence reduces to a quark bilinear times a momentum independent coefficient [2]. The quark bilinear operator can be defined as in [8],

$$\Theta^{(3,\bar{3})} \equiv \bar{s}(1 - \gamma_5)d, \quad (33)$$

which is equal to $\alpha^{(3,\bar{3})}\text{Tr}(\lambda_6 \Sigma)$ to lowest order in chiral perturbation theory, where in our conventions, $\alpha^{(3,\bar{3})} = \frac{-f^2}{2}B_0$. As illustrated in Sec. VI, the matrix elements of this operator can be used to eliminate the power divergences in the effective four-quark operator matrix elements [34]. This subtraction is to all orders in ChPT, and in Sec. VI we demonstrate this explicitly to NLO in the partially quenched theory, following the derivation in [2]. It is crucial that the subtraction be independent of ChPT, since the higher order corrections of the power divergent operator can far exceed the physical contributions that one is trying to calculate. In order to carry out the argument to NLO in (PQ)ChPT for the case of the $(8,1)$'s we need the

TABLE V. When the tadpole terms are subtracted via the $\Theta^{(3,\bar{3})}$ operator, the $(8,1)$ NLO coefficients are transformed to new linear combinations involving the Gasser-Leutwyler coefficients. These new combinations no longer have power divergences.

Transformed Coefficients
$e_1^r \rightarrow e_1^r - (4\alpha_2/f^2)(2L_8^r + H_2^r)$
$e_2^r \rightarrow e_2^r - (16\alpha_2/f^2)L_6^r$
$e_3^r \rightarrow e_3^r + (4\alpha_2/f^2)(-2L_8^r + H_2^r)$
$e_5^r \rightarrow e_5^r - (4\alpha_2/f^2)H_2^r$
$e_{10}^r \rightarrow e_{10}^r - (4\alpha_2/f^2)L_5^r$
$e_{13}^r \rightarrow e_{13}^r - (8\alpha_2/f^2)L_4^r$
$e_{15}^r \rightarrow e_{15}^r + (4\alpha_2/f^2)L_5^r$

NLO LEC contribution of the $\Theta^{(3,\bar{3})}$ operator. The effect of the subtraction involving this operator is to eliminate the LEC, α_2 , at leading order, and to transform the NLO $(8,1)$ coefficients to a linear combination involving the Gasser-Leutwyler coefficients. The chiral rotation eliminates the power divergent scale dependence (proportional to α_2) of the LEC's to NLO. The effect of this transformation on the individual coefficients is given in Table V.²

V. $K \rightarrow \pi\pi$ WITHOUT 3-MOMENTUM INSERTION

In [13] we have shown that all the amplitudes of interest for the $(8,1)$'s and $(27,1)$'s can be obtained to NLO in ChPT when one uses lattice computations from $K^0 \rightarrow \bar{K}^0$, $K \rightarrow |0\rangle$, $K \rightarrow \pi$ with momentum and $K \rightarrow \pi\pi$ at the two unphysical kinematics points UK1 [14] $\Rightarrow m_K = m_\pi$ and UK2 [15] $\Rightarrow m_K = 2m_\pi$. Specifically, these two points correspond to threshold, and, thereby, the Maiani-Testa theorem is evaded [9]. Here we ask how far one can get by *not* using 3-momentum insertion in $K \rightarrow \pi$ and using only nondegenerate quarks so that on the lattice $m_K \neq m_\pi$. In this case one is using energy insertion with $q^2 = (m_K - m_\pi)^2$. The motivation for this should be clear. Not only can 3-momentum insertion add to the computational cost, it also tends to be noisy. On the other hand, in a typical weak matrix element calculation, $m_K \neq m_\pi$ is relatively inexpensive to implement, since light quarks with several masses are needed anyway.

At $O(p^4)$ in $K \rightarrow \pi$ one can see explicitly [13] that different LEC's appear in front of $(p_K \cdot p_\pi)^2$ than in front of $m_K^2 m_\pi^2$. In general $p_K \cdot p_\pi \neq m_K m_\pi$, so it is not clear if all of the LEC's needed for constructing $K \rightarrow \pi\pi$ to $O(p^4)$ can be obtained if one restricts to no 3-momentum insertion in $K \rightarrow \pi$. We find that for all cases of interest without 3-momentum insertion, although some low-energy constants cannot be obtained, the linear combinations that are needed for constructing the physical NLO amplitude can always be obtained. This reduces the necessary com-

²The table is constructed using information given in [28].

putational effort considerably. This section will be restricted to demonstrating this result for the full theory, but in the next section we show that the same result holds also for the partially quenched case in the PQS framework. It is not known whether this continues to hold in the PQN framework, which is considerably more complicated at NLO.

In [13] we showed how to get physical $K \rightarrow \pi\pi$ amplitudes for both $\Delta I = 1/2$ and $3/2$ cases to NLO. Since $K \rightarrow \pi$ amplitudes do not conserve 4-momentum for $m_s \neq m_d$, it is necessary to allow the weak operator to transfer a 4-momentum, $q \equiv p_K - p_\pi$, as in [10]. This also is necessary for the case of $K \rightarrow \pi\pi$ at $m_K = m_\pi$ [14]. Our method [13] requires computation of $K \rightarrow \pi\pi$ at unphysical kinematics because there are low-energy constants which appear in $K \rightarrow \pi\pi$ but do not appear in $K \rightarrow \pi$ at all [11,30].

There exist other unphysical kinematics values (besides UK1 and UK2) for the $K \rightarrow \pi\pi$ amplitudes where the initial and final state mesons are at rest that are accessible to lattice calculations. These values of the kinematics bypass the Maiani-Testa theorem because the final state pions are at threshold, but energy insertion (or removal) at the weak operator has to take place in order to conserve 4-momentum. These amplitudes have no imaginary parts as long as $m_K \geq m_\pi$ ($m_s \geq m_{u,d}$ since then a two kaon intermediate state cannot go on shell) and so bypass the Maiani-Testa theorem. On the lattice, so long as one studies the appropriate correlation function as a function of Euclidean times and does not sum over the time index, the weak operator can insert (or remove) the necessary amount of energy. What we are calling UK1 ($m_K = m_\pi$) and UK2 ($m_K = 2m_\pi$) are just special examples of this more general kinematics which we call UKX, which is itself a special case of the SPQcdR kinematics (one pion at rest, the other with 3-momentum inserted) [12] where both pion 3-momenta are zero, and E_π , the energy of each pion, is equal to m_π .

We point out that the UKX kinematics is at threshold because of the ability of the weak operator to inject or remove the necessary energy so that the Maiani-Testa theorem is bypassed even for $\Delta I = 1/2$ amplitudes. As pointed out by [16], the case where $m_K = m_\pi$ has a number of difficulties, especially in the partially quenched theory. It is, therefore, necessary to consider the more general kinematics of UKX (with $m_K > m_\pi$) in order to bypass this problem. Using UKX, one can then obtain all of the LEC's necessary to construct the (8,1), $K \rightarrow \pi\pi$ amplitudes in both the full theory and in the partially quenched case, if a numerical calculation at UK1 is difficult or impossible. We present NLO results for UKX in the partially quenched theory in Sec. VIII.

Finally, it also is useful to emphasize that even when one works to LO, $K \rightarrow \pi$ with $m_K \neq m_\pi$ (without 3-momentum insertion) suffices to give $K \rightarrow \pi\pi$ at that

order, thus providing an alternate subtraction method to the one that has been used recently [1,2,6,7] with $K \rightarrow 0$ [8,35].

A. (27,1), $\Delta I = 3/2$

The expression for the physical $K \rightarrow \pi\pi$, including only tree-level $O(p^2)$ and $O(p^4)$ weak counterterms, is [13]

$$\begin{aligned} \langle \pi^+ \pi^- | \mathcal{O}^{(27,1),(3/2)} | K^0 \rangle_{\text{ct}} &= -\frac{4i\alpha_{27}}{f_K f_\pi^2} (m_K^2 - m_\pi^2) \\ &+ \frac{4i}{f_K f_\pi^2} (m_K^2 - m_\pi^2) \\ &\times [(-d_4^r + d_5^r - 4d_7^r)m_K^2 \\ &+ (4d_2^r + 4d_{20}^r - 16d_{24}^r - 4d_4^r \\ &- 2d_7^r)m_\pi^2]. \end{aligned} \quad (34)$$

The counterterm expressions needed to construct this physical amplitude are given in [13] Eqs. (22–24), and the finite logarithmic contributions are given there in Appendix C. Counterterms needed to construct the above $K \rightarrow \pi\pi$ amplitude can be obtained from $K^0 \rightarrow \bar{K}^0$; $K^+ \rightarrow \pi^+$, $\Delta I = 3/2$ (nondegenerate quarks); and $K \rightarrow \pi\pi$, $\Delta I = 3/2$ at only one value of the unphysical kinematics (e.g., UK1³). Note that the expression for $K^+ \rightarrow \pi^+$, $\Delta I = 3/2$ reduces, for the case of no 3-momentum insertion, i.e., $q^2 = (m_K - m_\pi)^2$, to

$$\begin{aligned} \langle \pi^+ | \mathcal{O}^{(27,1),(3/2)} | K^+ \rangle_{\text{ct}} &= -\frac{4}{f^2} \alpha_{27} m_K m_\pi \\ &+ \frac{8}{f^2} [(2d_2^r - 8d_{24}^r)m_K^2 m_\pi^2 \\ &+ (d_{20}^r - d_4^r - 2d_7^r)m_K^3 m_\pi \\ &+ (d_{20}^r - d_4^r - d_7^r)m_K m_\pi^3], \end{aligned} \quad (35)$$

The logarithmic corrections to this expression reduce to the value given in Appendix C of this paper. Fits to the $K \rightarrow \pi$ data can therefore give d_7^r , $d_{20}^r - d_4^r$, and $d_2^r - 4d_{24}^r$. Using these in the $K \rightarrow \pi\pi$ amplitude at the unphysical kinematics point (UK1) $m_K = m_\pi = m$ (Eq. (23) of [13]) gives $d_4^r - d_5^r$. The four linear combinations [$d_2^r - 4d_{24}^r$, d_7^r , $d_4^r - d_5^r$, $d_4^r - d_{20}^r$] are sufficient to determine $K \rightarrow \pi\pi$, $\Delta I = 3/2$ at the physical kinematics as given in Eq. (34). Comparing Eq. (35) with the more general case of 3-momentum insertion, Eq. (22) of [13], we see that the latter allows for separate determinations of d_2^r and d_{24}^r , whereas the simpler case of $m_K \neq m_\pi$ without 3-momentum insertion, Eq. (35), gives only the linear combination $d_2^r - 4d_{24}^r$. Nevertheless, that suffices to get the job done.

³For the $\Delta I = 3/2$ case there is no difficulty at UK1.

B. (8, 1) + (27, 1), $\Delta I = 1/2$

Recall that this is the most complicated case. The counterterms necessary to construct $\mathcal{O}(p^4)$, [(8, 1) + (27, 1)], $\Delta I = 1/2$, $K \rightarrow \pi\pi$ amplitudes relevant for operators such as $Q_2^{1/2}$, which are mixed, can be obtained from the above values for d_i^r 's and from the following $\Delta I = 1/2$ processes: $K^0 \rightarrow 0$; $K^+ \rightarrow \pi^+$, $\Delta I = 1/2$ (nondegenerate quarks) and $K \rightarrow \pi\pi$, $\Delta I = 1/2$ at two unphysical kin-

$$\begin{aligned} \langle \pi^+ | \mathcal{O}^{(27,1),(1/2)} | K^+ \rangle_{\text{ct}} = & -\frac{4}{f^2} \alpha_{27} m_K m_\pi - \frac{8}{f^2} [6d_1^r m_K^4 + (-6d_1^r - 2d_2^r + 8d_{24}^r) m_K^2 m_\pi^2 \\ & + (-d_{20}^r + d_4^r - 3d_6^r + 2d_7^r) m_K^3 m_\pi + (-d_{20}^r + d_4^r + 3d_6^r + d_7^r) m_K m_\pi^3], \end{aligned} \quad (36)$$

$$\begin{aligned} \langle \pi^+ | \mathcal{O}^{(8,1)} | K^+ \rangle_{\text{ct}} = & \frac{4}{f^2} \alpha_1 m_K m_\pi - \frac{4}{f^2} \alpha_2 m_K^2 - \frac{8}{f^2} [2(e_1^r + e_2^r - e_5^r) m_K^4 + (e_2^r + 2e_3^r + 2e_5^r - 8e_{39}^r) m_K^2 m_\pi^2 \\ & + (2e_{35}^r - 2e_{10}^r) m_K^3 m_\pi + (2e_{35}^r - e_{11}^r) m_K m_\pi^3], \end{aligned} \quad (37)$$

The logarithmic corrections associated with the above two amplitudes are given in Appendix C of this paper. In evaluating, for example, $\langle \pi^+ | Q_2^{1/2} | K^+ \rangle$, the right-hand sides of Eqs. (36) and (37) have to be added. In fitting to lattice data, for example, the m_K^4 coefficient would give the combination $[6d_1^r + 2e_1^r + 2e_2^r - 2e_5^r]$. Also, in comparing Eq. (37) with Eq. (29) in [13] without 3-momentum insertion, one can no longer separately obtain $(e_2^r + 2e_3^r + 2e_5^r)$ and $-8e_{39}^r$ but only their sum; however, this is again sufficient to obtain the physical $K \rightarrow \pi\pi$ amplitudes ([13] Eqs. (34), (35)) to NLO.

We point out that for the $\Delta I = 1/2$ amplitudes there are power divergences that must be subtracted using the $\Theta^{(3,3)}$ operator introduced at the end of Sec. IV. It is crucial that the subtraction is to all orders in ChPT, since the higher order corrections of the power divergent operator can far exceed the physical contributions that one is trying to determine. This is discussed in more detail in Secs. VII and VIII for the partially quenched case, where we follow the derivation in [2], given for the leading order case in the full theory (although there the analysis was done with quenched data). The result of the subtraction is to eliminate the power divergent coefficient α_2 and to transform the (8,1) NLO LEC's to the values given in Table V. Thus, fits to the subtracted lattice data will give the transformed coefficients, where their power divergences have been eliminated. This is what we want, since only these finite combinations appear in physical quantities. The process described in the above discussion on the determination of the NLO LEC's, along with that in [13], is not invalidated.

One can determine, using the $\Delta I = 3/2$ amplitudes, the following constants: $[d_1^r, d_2^r - 4d_{24}^r, d_7^r, d_4^r - d_5^r, d_4^r - d_{20}^r]$. Here d_1^r and d_7^r can both be determined from $K \rightarrow \bar{K}$ ([13], Eq. (21)), and the procedure for the others is given in the previous section. Given these, one can obtain $e_{2,\text{rot}}^r$ and $e_{1,\text{rot}}^r - e_{5,\text{rot}}^r$ from $K^0 \rightarrow 0$. Note that the values of the

coefficients. All of the needed counterterm amplitudes appear in Sec. IV.B of [13], and the corresponding logarithmic corrections appear in Appendix D of that paper. Note that an error was discovered since publication of that work in Eq. (31) and in Appendix D, Eq. (D6). The correct expressions appear here in Appendix F. Again, it is sufficient to allow $q^2 = (m_K - m_\pi)^2$ in the expression for $K \rightarrow \pi$, [13] Eqs. (28) and (29). These equations become

coefficients obtained are those of the subtracted amplitudes, and that the subscript refers to the LEC after the chiral rotation of Table V has been performed. Only after the subtraction can one fit to the lattice data using ChPT. Given the previous information one can obtain $e_{1,\text{rot}}^r + e_{3,\text{rot}}^r - 4e_{39}^r$, $e_{10,\text{rot}}^r - e_{35}^r + \frac{3}{2}d_6^r$, and $2e_{10,\text{rot}}^r - e_{11}^r + 6d_6^r$ from Eqs. (36) and (37), after the subtraction has been performed. From Eqs. (30) and (31)⁴ of Ref. [13] for $K \rightarrow \pi\pi$, $m_K = m_\pi = m$ (UK1⁵), one can then obtain $e_{11}^r + 2e_{15,\text{rot}}^r - 3d_6^r$. Making use of all of the input thus obtained into Eqs. (32) and (33) of Ref. [13] for $K \rightarrow \pi\pi$, $m_K = 2m_\pi$ (UK2), yields $e_{13,\text{rot}}^r - \frac{3}{2}d_6^r$ (after the subtraction). Thus, the 11 linear combinations necessary to construct the physical $K \rightarrow \pi\pi$ at NLO (without using 3-momentum insertion but with nondegenerate quarks in $K \rightarrow \pi$) are

$$\begin{aligned} & [d_1^r, d_2^r - 4d_{24}^r, d_7^r, d_4^r - d_5^r, d_4^r - d_{20}^r, e_{2,\text{rot}}^r, e_{1,\text{rot}}^r + e_{3,\text{rot}}^r \\ & - 4e_{39}^r, e_{10,\text{rot}}^r - e_{35}^r + \frac{3}{2}d_6^r, 2e_{10,\text{rot}}^r - e_{11}^r + 6d_6^r, e_{11}^r \\ & + 2e_{15,\text{rot}}^r - 3d_6^r, e_{13,\text{rot}}^r - \frac{3}{2}d_6^r]. \end{aligned}$$

C. (8,1)

The case of pure (8,1) operators, e.g., Q_6 , is simpler than the previous case of mixed $\Delta I = 1/2$ operators and is phenomenologically the most important one as it gives

⁴Note that Eq. (31) of [13] is corrected in Appendix F, but this does not change the conclusion here.

⁵Although [16] have pointed out that UK1 may be computationally demanding even for the full theory, it is not ruled out. In any case, for extracting the LEC's one can use the more general kinematics which we call UKX, as discussed earlier in this section.

the dominant contribution to the CP-odd phase of ϵ'/ϵ coming from QCD penguins. For this case the six needed linear combinations are $[e_{2,\text{rot}}^r, e_{1,\text{rot}}^r + e_{3,\text{rot}}^r - 4e_{39}^r, e_{35}^r - e_{10,\text{rot}}^r, 2e_{35}^r - e_{11}^r, e_{11}^r + 2e_{15,\text{rot}}^r, e_{13,\text{rot}}^r]$. The first of these is obtained from $K \rightarrow 0$. The second requires both $K \rightarrow 0$ and $K \rightarrow \pi$ ($m_K \neq m_\pi$). The third and fourth are also obtained from $K \rightarrow \pi$. $K \rightarrow \pi\pi$ at UK1 then gives the fifth, and $K \rightarrow \pi\pi$ at UK2 gives the sixth coefficient. Since it is likely that UK1 will prove to be particularly difficult [16], it is possible to use another set of allowed values of UKX in order to obtain the remaining coefficients. Of course, one will want to do such a calculation using UKX anyway for the additional redundancy. All LEC's are those that would be obtained from a fit to lattice data after the power divergent subtraction has been performed.

D. (8,8)

Since the leading order (8,8) begins at $O(p^0)$, the NLO contribution comes at $O(p^2)$. As an example, Eq. (36) from [10] is given (with our normalization of f and our convention for the c_i 's),

$$\langle \pi^0 | \mathcal{O}^{(8,8)} | K^0 \rangle_{\text{ct}} = \frac{2\sqrt{2}}{f^2} \left[-\left(\frac{1}{3}c_1 + c_2 + \frac{2}{3}c_3\right) p_K \cdot p_\pi - \frac{2}{3}c_4 m_K^2 \right]. \quad (38)$$

Now with $m_K \neq m_\pi$, even when both mesons are at rest, and $p_K \cdot p_\pi = m_K m_\pi$, there is no loss of information, and all the coefficients can be obtained at NLO without 3-momentum insertion.

VI. CALCULATING $K \rightarrow \pi\pi$ AMPLITUDES IN PQChPT

In this section we discuss the ambiguity of PQChPT in the $\Delta I = 1/2$ case where eye diagrams appear. At least two ways arise in the context of PQChPT for dealing with the gluonic penguins, the PQS and the PQN methods. These are described, and their predictions at leading order are compared using formulas given by Golterman and Pallante. In the following subsections we give NLO expressions in PQChPT for the ingredients necessary to obtain $K \rightarrow \pi\pi$ at $O(p^2)$ and $O(p^4)$ for the (8,8)'s and (8,1)'s, respectively. For the (8,8)'s it is necessary to know $K \rightarrow \pi$, $\Delta I = 3/2$ and $1/2$ in order to get all the coefficients at NLO, as shown in [10]. This remains true in PQChPT. The important point to note is that one can construct $K \rightarrow \pi\pi$ amplitudes for the (8,8) operator to NLO using only $K \rightarrow \pi$ with degenerate quark masses ($m_K = m_\pi$), along with $K \rightarrow 0$ to perform the $\Delta I = 1/2$ power subtraction.

For the (8,1)'s, one needs $K \rightarrow 0$, $K \rightarrow \pi$ with non-degenerate quarks, and $K \rightarrow \pi\pi$ at two values of unphysical kinematics, e.g., $m_K = m_\pi$ (UK1) and $m_K = 2m_\pi$

(UK2), as shown in [13] in full ChPT to NLO. We also have introduced in Sec. V the kinematics for $K \rightarrow \pi\pi$ accessible to the lattice which we have called UKX, of which UK1 and UK2 are special cases. Reference [16] has demonstrated that UK1 has difficulties in the full theory and is not tractable in the partially quenched theory due to enhanced finite volume effects. One can still obtain all of the needed LEC's to construct $K \rightarrow \pi\pi$ to NLO for the (8,1)'s from UKX, however. This remains true in PQChPT only when one is working within the PQS framework. This paper, therefore, follows the prescription of the PQS method for the (8,1)'s. Note that in the PQN method it is not clear if all the ingredients needed for constructing the physical $K \rightarrow \pi\pi$ amplitudes to NLO can be determined from the lattice, except in the full theory ($N = 3$, $m_{\text{sea}} = m_{\text{val}}$) where the two methods coincide. Note, also, that the (8,1), $K \rightarrow \pi\pi$ amplitudes at UKX are afflicted by enhanced finite volume corrections except when $m_{\text{sea}} = m_u = m_d$ for both the PQS and PQN methods.

In the PQChPT case (as in full ChPT) the $K \rightarrow \pi$ amplitudes require nondegenerate quarks, $m_s \neq m_u = m_d$, in order to extract all of the necessary LEC's from them. Since this amplitude does not conserve 4-momentum, for $m_s \neq m_d$ the weak operator must transfer a 4-momentum $q \equiv p_K - p_\pi$. The conclusion of the previous section that 3-momentum insertion is not essential holds also in the case of PQChPT.

The diagrams to be evaluated for the NLO corrections are shown in Fig. 1. The topologies are unchanged from [13], although additional pseudofermion ghost and sea meson fields propagate in the loops. The renormalization of the external legs via the strong interaction must be taken into account.

A. The treatment of eye-graphs

There is a subtlety concerning the $\Delta I = 1/2$ amplitudes in the partially quenched theory, and this has been discussed by Golterman and Pallante for the case of the gluonic penguins [21,30,36]. What follows is a summary of their work. To illustrate the subtlety, we discuss the situation for the Q_6 gluonic penguin operator, given by

$$Q_6 = \bar{s}_a \gamma_\mu (1 - \gamma^5) d_b \sum_q \bar{q}_b \gamma^\mu (1 + \gamma^5) q_a. \quad (39)$$

The right part of this operator is a sum over light flavors $q = u, d, s$ so in the full theory the right-hand part is a flavor singlet under the symmetry group $SU(3)_R$. In the partially quenched theory one has at least two options. One may choose to sum over all the quarks, including sea and ghost in which case the right component of the operator transforms as a singlet under the extended symmetry group; therefore, this is called the PQS (partially quenched singlet) option. In the second option, one may choose to sum in Eq. (39) over only the valence quarks. In this case the operator is a linear combination of two terms, one of

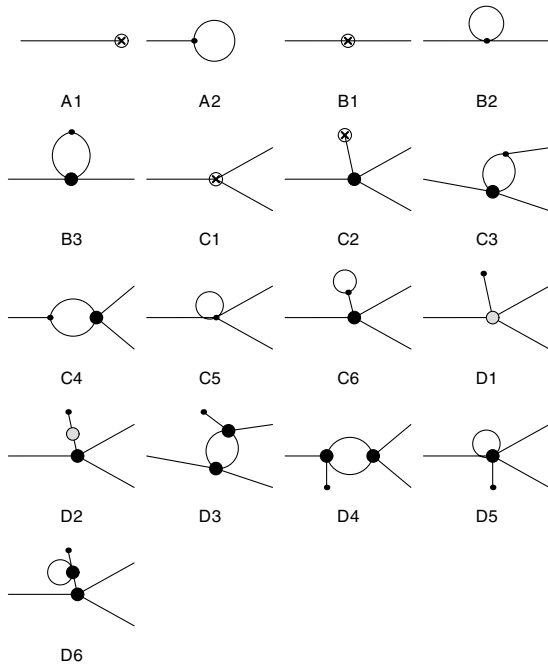

FIG. 1. Diagrams needed to evaluate the NLO amplitudes in (PQ)ChPT. NLO corrections include tree-level diagrams with insertion of the NLO weak vertices (crossed circles), tree-level diagrams with insertion of $O(p^4)$ strong vertices (lightly shaded circles), one-loop diagrams with insertions of the LO weak vertices (small filled circles) and the $O(p^2)$ strong vertices (big filled circles). The lines represent the propagators of mesons comprised of valence, ghost, and sea quarks. (A1–A2) are for $K \rightarrow 0$. (B1–B3) are for $K \rightarrow \pi$. (C1–C6) and (D1–D6) are for $K \rightarrow \pi\pi$.

which transforms as a singlet under the extended symmetry group, while the other does not transform as a singlet under the irreducible representation of the extended symmetry group (rather, for Q_6 , it transforms in the adjoint representation); therefore, we choose to call this the PQN method.

Given that the flavor blind, vector character of the quark-quark-gluon elementary interaction in QCD plays a crucial role in leading to the explicit singlet form [Eq. (39)] of the right-hand part of the penguin operator, it seems reasonable to preserve this basic character in generalization to the partially quenched case which contains additional quarks. This provides the rationale for the PQS option.

The origin of the PQN option is quite different; it is, in fact, the straightforward implementation of the quenched approximation to a lattice calculation of the necessary Green's functions. The usual practice leads one to use only the valence quarks in the necessary Wick contractions for, say $\langle \pi | Q_6 | K \rangle$, which then lead to valence quark loops (see Fig. 2(a) and 2(b)), the so-called eye graphs. In such an implementation all other quark loops are computed when the fermion determinant is evaluated in the generation of the gauge configurations. When one partially quenches in the PQN method, the gauge configurations are generated

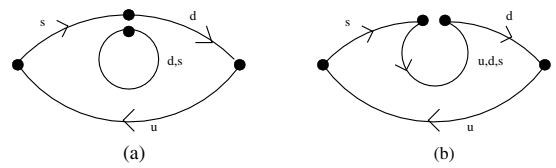

FIG. 2. The quark contractions needed for $K \rightarrow \pi$, $\Delta I = 1/2$ matrix elements include the above eye diagrams. A connected line represents a trace over color indices, so (a) represents a product of two color traces, whereas (b) represents a single color trace.

using the number and mass of the sea quarks, but the propagators for the loops of the eye graphs (Fig. 2(a) and 2(b)) are still computed with those of the valence quarks. In the partially quenched case where the sum in Eq. (39) is over the valence quarks only, as mentioned above, the operator is a linear combination of two terms, only one of which transforms as a singlet under the extended symmetry group.

Figure 2 shows the Green's function relevant for a lattice evaluation of $\langle \pi | Q_6 | K \rangle$ consisting of the two eye graphs originating from the Wick contractions. Any number of gluon lines from the background gauge configurations (not explicitly shown) are understood in such a pictorial representation of these nonperturbative graphs. As usual, one of the Wick contractions is a product of two color traces (Fig. 2(a)), while the second is a single trace over color indices. In the PQS implementation of the Q_6 penguin operator, in the quenched case where $q\bar{q}$ loops in the gluon propagation are not included, the eye graph (Fig. 2(b)) with a single color trace should also be excluded, for consistency [21,36].

In the PQN option of calculating $\langle \pi | Q_6 | K \rangle$, one uses valence quarks for the propagators of the eye graphs in the corresponding Green's function, as this appears analogous to the usual practice in lattice computations. However, the situation at hand demands caution. Lattice calculation of $\langle \pi | Q_6 | K \rangle$ is qualitatively different in important aspects from (say) spectrum, decay-constant or form-factor calculations.

To trace the potential inconsistency we show the weak operator with a magnified view in the nonperturbative eye graph (Fig. 3). Inside the dashed lines is the magnified short distance effective penguin operator; outside of these dashed lines any number of soft gluon lines from the background gauge configurations are understood, just as in Fig. 2. For $\langle \pi | Q_6 | K \rangle$, Fig. 3(a) and 3(b) correspond to the product of two color traces (Fig. 2(a)) and Fig. 3(c) corresponds to the single trace over color indices (Fig. 2(b)). Figure 3(c) shows clearly that the corresponding Wick contraction (single trace over color indices for Q_6 , i.e., Fig. 2(b)) in a lattice evaluation of $\langle \pi | Q_6 | K \rangle$ contains a $q\bar{q}$ loop in the propagation of the gluon, and since in the quenched case these are being dropped from

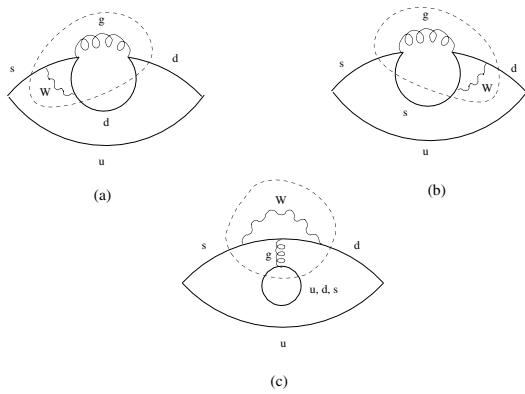

FIG. 3. The quark contractions needed for $K \rightarrow \pi$, $\Delta I = 1/2$ matrix elements include the above eye diagrams. The weak operator is shown with a magnified view inside the dashed lines so that one can see how it arises in perturbation theory for the gluonic penguins. (a) corresponds to \bar{q} being contracted with d , while (b) corresponds to q being contracted with \bar{s} . (c) corresponds to q being contracted with \bar{q} . For the electro-weak penguins, one would replace the gluon lines with those of photons or Z 's.

the background gauge configurations one may wish to exclude Fig. 2(b) (for Q_6) in the quenched approximation. In a similar vein, for the partially quenched case one may, for consistency, take the quark loop in the eye graph of Fig. 2(b) (Fig. 3(c)) to be that of sea quarks only [21,36], as in the PQS method. This lack of consistent (partial) quenching causes the low-energy dynamics of (P)QChPT to change between PQS and PQN methods. It is not clear if the additional (partially) quenched nonsinglet terms that modify the low-energy dynamics correctly account for the otherwise neglected loop contractions, or if the (partially) quenched low-energy constants from the singlet operator alone substituted into the full ChPT formulas for $K \rightarrow \pi\pi$ provide a better estimate for the physical amplitudes. Thus, the appearance of eye diagrams has created an ambiguity because the contraction of Fig. 3(c) yields a quark vacuum bubble, and it is not obvious whether the propagators to be contracted should be the sea or the valence; again, the first choice corresponds to PQS and the second to PQN.

The correspondence between the traditional form of the nonperturbative eye graphs as shown in Fig. 2 and the nonperturbative eye graphs with the magnified view of the penguin operator as shown in Fig. 3 for all penguin operators is as follows: For the Q_3 and Q_5 operators, the color contraction of Fig. 2(a) corresponds to Fig. 3(c), while the color contraction of Fig. 2(b) corresponds to Figs. 3(a) and 3(b). For the Q_4 and Q_6 operators, the color contraction of Fig. 2(a) corresponds to Figs. 3(a) and 3(b), while the color contraction of Fig. 2(b) corresponds to Fig. 3(c). For the electro-weak penguins, the picture in Fig. 3 carries over, but with the gluons replaced by a photon or a Z . In that case, for Q_7 the color contraction of Fig. 2(a) corresponds to Fig. 3(c), while the color con-

traction of Fig. 2(b) corresponds to Figs. 3(a) and 3(b). For Q_8 , the color contraction of Fig. 2(a) corresponds to Figs. 3(a) and 3(b), while the color contraction of Fig. 2(b) corresponds to Fig. 3(c). In short, Fig. 2(a) corresponds to Fig. 3(c) for the operator Q_i , $i = 3 - 8$, i odd, while Fig. 2(b) corresponds to Fig. 3(c) for i even.

The treatment of ChPT for the case when only valence quarks are contracted in the eye diagrams was first discussed by [21], for the case of the gluonic penguins. When one includes only the valence propagators in the eye diagrams (no partial quenching of the effective operator) for the case of the gluonic penguins the right-hand part of the $(8,1)$'s is no longer a singlet, and there is a contribution from a nonsinglet operator. For the left-left gluonic penguins, Q_3 and Q_4 , these nonsinglet contributions do not occur until next-to-leading order [36]. For the left-right gluonic penguins, Q_5 and Q_6 , the nonsinglet operator transforms under the same irreducible representation as the $(8,8)$ electro-weak penguins. Since the $(8,8)$'s are NLO at $O(p^2)$, even the leading order gluonic penguins can have logarithmic contributions from the one-loop insertions of the lowest order $(8,8)$ operator. These were calculated in [36] for the left-right gluonic penguins, Q_5 and Q_6 . Since the amplitudes in this case no longer transform as pure $(8,1)$'s, but pick up a contribution from the $(8,8)$'s, this calculation corresponds to the PQN method. It is useful to compare the (PQ)ChPT expressions for the PQS and PQN methods, and the next section compares the two methods at leading order for the left-right gluonic penguins, using expressions derived by Golterman and Pallante [21,30,36].

We choose to work within the framework of [30], where the PQS method was (implicitly) used. In this case there is the possibility of determining the LEC's to NLO. For the left-right gluonic penguins, for example, at NLO in the PQN method there are many more LEC's that appear in the amplitudes we are considering than in the PQS method. These are the $O(p^4)$ LEC's of the $(8,8)$ NNLO local operators, and it is not even clear whether one can determine the correct linear combinations of the new LEC's necessary to construct $K \rightarrow \pi\pi$ at NLO in ChPT from the PQN method, except when $N = 3$ and $m_{\text{sea}} = m_{\text{val}}$ (i.e., full QCD), as in that special situation the two options coincide. On the other hand, for the PQS method, no new ingredients are needed over the ones listed in our previous work [13] which were needed for the case of full ChPT.⁶ The PQS method can also be applied to obtain all of the needed LEC's to construct $K \rightarrow \pi\pi$ to NLO for the case

⁶Note that [16] have shown that there are difficulties at what we call UK1 ($K \rightarrow \pi\pi$ with $m_K = m_\pi$). There is, however, an additional set of kinematics points that bypass the Maiani-Testa theorem, creating the two pion state at threshold with energy carried by the weak operator which we call UKX. If UK1 proves difficult or impossible one must supplement the other ingredients with a calculation of $K \rightarrow \pi\pi$ at UKX with $m_K > m_\pi$.

$N = 2$ (using the same ingredients as for the full theory), though in this case the LEC's are not necessarily the same as in the $N = 3$ physical case.

To reiterate, in general, the PQN method is complicated by the contributions of many more LEC's, and it is not known whether this method can be used to NLO. Such a determination would require a two-loop calculation. The PQS method gives us everything we need and is the *only* method where we have demonstrated that it is possible to obtain $K \rightarrow \pi\pi$ to NLO in ChPT. Thus, we use the PQS prescription.

As discussed in [21], the NLO (8,8) LEC's that appear in linear combinations with the LO (8,1) LEC's in the PQN expressions for the amplitudes of the left-right gluonic penguins are not present for the PQS method. For the case where $N = 3$, there is no ambiguity, and one must extract the (8,1) LEC's separately since these LEC's take the same values as in the full theory. However, when N is *not* equal to 3, it may be that the additional (8,8) LEC's appearing in linear combinations with the (8,1) LEC's bring the $N \neq 3$ values of the (8,1) LEC's to closer agreement with the $N = 3$ values of the real world. As long as an explicit $N = 3$ lattice calculation is lacking, it may be useful to compare the determinations of both PQN and PQS leading order LEC's at other values of N in order to learn something of the size of the systematic error due to partial quenching [21,36]. This is discussed further for $Q_{5,6}$, LO $K \rightarrow \pi\pi$ amplitudes in the next subsection.

This paper requires $K \rightarrow 0$, $K \rightarrow \pi$, $m_s \neq m_d = m_u$, and $K \rightarrow \pi\pi$ at two unphysical kinematics in order to construct the physical (8,1), $K \rightarrow \pi\pi$ amplitude for any gluonic penguin operator ($Q_{3,4,5,6}$) using the PQS prescription. Reference [30] presented $K \rightarrow 0$, and $K \rightarrow \pi$, $m_s = m_u = m_d$, and we agree with those calculations in the case we consider, namely, the partially quenched case with $m_{\text{val}}, m_{\text{sea}} \ll m_{\eta'}$. We extend these calculations to include all amplitudes needed to obtain the (8,1) LEC's necessary to construct $K \rightarrow \pi\pi$ to NLO.

In the case of the (8,8), $\Delta I = 1/2$ amplitudes, one also must make this choice of whether to (partially) quench the right side of the penguin operator. In this case, however, the difference comes in the choice of the quark charge matrix, Q . If we choose the ghost quark charges to be equal to the valence quark charges, then we quench the electro-weak penguins, and one should ignore the valence contributions to Fig. 3(c) (with the gluon replaced by a photon or Z , Fig. 3(c) corresponds to Fig. 2(a) for Q_7 and to Fig. 2(b) for Q_8) in the lattice calculation. However, if one chooses the ghost quarks to have zero charge then the electro-weak interaction remains unquenched, and one must include the valence quarks in Fig. 3(c) in the lattice calculation. In both cases the sea quark loop contributions to Fig. 3(c) vanish if we assume degenerate sea quark masses and that the sum of the sea quark charges is zero. The logarithmic expressions resulting from either choice for the (8,8)'s are presented in Appendix D.

To summarize, our calculation for the (8,1) gluonic penguin matrix elements corresponds to the PQS method. In the corresponding lattice calculation, the eye contractions of Fig. 3(c) (corresponding to Fig. 2(a) for Q_3 , Q_5 , and Q_7 , and to Fig. 2(b) for Q_4 , Q_6 , and Q_8) include only the sea quarks. That is, the propagator of the internal loop of Fig. 3(c) is calculated with the masses of the sea quarks, not the valence quarks. As discussed above, when $N = 3$, this, the PQS method, allows for the only known implementation of the reduction method for the gluonic penguins. It greatly simplifies the LO analysis [36] and makes possible a NLO determination of all of the necessary LEC's, as demonstrated in this paper. For the (8,8) electro-weak penguin matrix elements, for degenerate sea quark masses the eye graph of Fig. 3(c) (with the gluon replaced by a photon) vanishes for any number of dynamical flavors by construction (see Sec. IV). Whether one chooses to include valence quarks in the loop of Fig. 3(c) does not significantly alter the situation in PQChPT, and formulas for both implementations are given in this paper.

B. PQS vs PQN at leading order

This section is a review of Golterman and Pallante's [21,30,36] results for the leading order, left-right gluonic penguins, Q_5 and Q_6 . Table VI compares the results of the PQS method versus those of the PQN method. The results are for the subtracted $K \rightarrow \pi$ matrix elements, where the (large) subtraction is performed using $K \rightarrow 0$. For details on how this subtraction is performed, see [2]. The end result of this subtraction in the case of full QCD (no quenching) is just $\alpha_1^{N=3}$, which is the physical LO LEC that contributes to $K \rightarrow \pi\pi$. In this case, the two methods, PQS and PQN, are procedurally the same, and they therefore give the same answer.

When $N = 3$, but $m_{\text{sea}} \neq m_{\text{val}}$, the LEC's in the amplitudes are still those of the full theory, but an additional LEC, the leading order (8,8) electro-weak penguin LEC α_{88} contributes in the PQN case to $K \rightarrow 0$ multiplied by some logarithmic terms [21]. Thus, a subtraction that is performed without taking this into account has a contamination. That is, there is an extra term appearing at leading order that must be accounted for in fits used to obtain the subtraction coefficient from $K \rightarrow 0$. Looking in Table VI at the PQS result, we see that this method is simpler. At NLO the difference is even more severe, so that PQS is the only method shown to be feasible. In this case the difference in practice between the two methods is whether one uses the sea mass or the valence mass in the propagator of the loop in Fig. 3(c). (See the preceding section for the correspondence between Fig. 3(c) and the traditional form of the eye diagrams in Fig. 2 for the various operators.)

When $N = 2$ the LEC's are no longer those of the full theory, and an ambiguity results. In this case the calcula-

TABLE VI. The leading order LEC's as determined in PQChPT from $K \rightarrow \pi$ after using the $K \rightarrow 0$ subtraction described in [2] are presented. They are compared for the PQS and PQN methods in the case of the left-right gluonic penguins. The two methods agree for the full QCD case. For the $N = 3$, $m_{\text{sea}} \neq m_{\text{val}}$ case there is a logarithmic contamination for the case of PQN. That is, there is an extra term appearing at leading order that must be accounted for in fits used to obtain the subtraction coefficient from $K \rightarrow 0$. For $N = 2$, the LEC's are not those of the full theory, and additional terms appear for the PQN case. For $N = 0$, the quenched case, there also are additional terms that contribute in the PQN case. See [21,36] for the derivations of these results and the values of the logarithmic corrections abbreviated here.

$N = 3, m_{\text{sea}} = m_{\text{val}}$ (Full QCD)	
PQS	PQN
$\alpha_1^{N=3}$	$\alpha_1^{N=3}$
$N = 3, m_{\text{sea}} \neq m_{\text{val}}$	
PQS	PQN
$\alpha_1^{N=3}$	$\alpha_1^{N=3} + \alpha_{(8,8)}^{N=3}$ (log terms)
PQS	PQN
$\alpha_1^{N=2}$	$\frac{3}{2}\alpha_1^{N=2} + \frac{1}{(4\pi)^2}(\beta_1^{(8,8)} + \frac{1}{2}\beta_2^{(8,8)}) + \alpha_{N=2}^{(8,8)}$ (log terms)
PQS	PQN
$\alpha_1^{N=0}$	$\frac{1}{2}\alpha_1^{N=0} - \frac{1}{(4\pi)^2}(\beta_1^{NS} + \frac{1}{2}\beta_2^{NS}) + \alpha_Q^{NS}$ (log terms)

tions differ in that for the loop of Fig. 3(c) for PQS one uses two flavors with the dynamical mass, while for PQN one uses three flavors with the valence masses. Here, $\alpha_{88}^{N=2}$ appears multiplied by logarithmic terms, and these must be removed in the fits to $K \rightarrow 0$ before the subtraction can be performed. Notice also the presence of the β terms in linear combination with the $\alpha_1^{N=2}$ term. These β terms always appear in the same linear combination with $\alpha_1^{N=2}$, including in the expression for $K \rightarrow \pi\pi$. Thus, it is not obvious whether they represent a correction to the $\alpha_1^{N=2}$ term or a contamination. Clearly, it will be important to compare the results of both methods. Note also that the β terms that appear with $\alpha_1^{N=2}$ have a scale dependence proportional to $\alpha_{88}^{N=2}$, and that if $\alpha_{88}^{N=2}$ is not so far from $\alpha_{88}^{N=0}$, as determined in [2], then this scale dependence would be large. It would then be necessary to include the partially quenched chiral logs proportional to $\alpha_{88}^{N=2}$ in $K \rightarrow \pi\pi$ in order to cancel the scale dependence and obtain a consistent answer. It would be extremely useful to have (at least so long as an $N = 3$ calculation is not available) a study of the subtracted LO constants for the PQS and PQN methods as a function of N , so that one could try to extrapolate each result to $N = 3$ and compare the two.

Note that the β terms are related to the (8,8) LEC's, c_i in the terminology of this paper. The correspondence to our

notation is

$$\begin{aligned} \beta_1^{(8,8)} &= (4\pi)^2 2c_3, & \beta_2^{(8,8)} &= (4\pi)^2 2c_1, \\ \beta_3^{(8,8)} &= (4\pi)^2 2c_4. \end{aligned} \quad (40)$$

Finally, when $N = 0$ the theory is completely quenched. This corresponds to ignoring all contractions of the kind in Fig. 3(c) for the PQS method and keeping them with the valence quarks for PQN. In the quenched case, the additional LEC's for PQN, the α_Q^{NS} and β_i^{NS} , are coefficients of nonsinglet operators, but they have no relation to the (8,8) electro-weak penguins. Golterman and Pallante [21] provide a possible recipe for determining α_Q^{NS} on the lattice. Analogous to the partially quenched case, if α_Q^{NS} is large, it would imply a large scale dependence on the subtracted combination of LEC's in the PQN method, which would have to be cancelled by the quenched logs proportional to α_Q^{NS} in $K \rightarrow \pi\pi$ in order to obtain a consistent, scale independent answer. There are indications from the large N_c (N_c is the number of colors) approximation that the LEC α_Q^{NS} is indeed large compared to $\alpha_1^{N=0}$ [37]. Again, it is not clear if the nonsinglet terms represent a correction or a contamination, and results for both methods should be compared as part of an extrapolation in N .

VII. (PARTIALLY) QUENCHED (8,8)'S TO NLO

In this section we present the results for the partially quenched $K \rightarrow \pi$ and $K \rightarrow 0$ amplitudes needed to construct the $K \rightarrow \pi\pi$ amplitudes to NLO for the (8,8)'s. The power divergent subtraction is discussed for the $\Delta I = 1/2$, $K \rightarrow \pi$ amplitude. Formulas are presented for $K \rightarrow 0$ and $K \rightarrow \pi$ for nondegenerate quark masses, as well as $K \rightarrow \pi$ for degenerate quark masses. It is demonstrated that $K \rightarrow \pi$ with degenerate masses is sufficient to construct $K \rightarrow \pi\pi$ to NLO in the partially quenched theory, while $K \rightarrow \pi$ with nondegenerate quark masses gives additional redundancy in determining the NLO LEC's.

We show that in the case of $K \rightarrow \pi$ with degenerate quark mass, the $N = 0$ limit of our expressions produces the quenched result, which will be useful for fits to already existing lattice data. It is important to notice that not all LEC's needed for NLO $K \rightarrow \pi\pi$ can be determined from the quenched $K \rightarrow \pi$ data, since c_6^r , which is needed in the physical $K \rightarrow \pi\pi$ expressions, does not appear in the quenched $K \rightarrow \pi$ formulas. One can see the scale dependence of the LEC's from the formula,

$$c_i^r(\mu_2) = c_i^r(\mu_1) + \frac{2\alpha_{88}\eta_i}{(4\pi f)^2} \ln \frac{\mu_1}{\mu_2}, \quad (41)$$

which can be obtained from Eq. (19), the definition of the renormalized LEC's. The coefficients η_i are given in Table III. Since the scale dependence of the c_6^r coefficient in the physical $K \rightarrow \pi\pi$ amplitude is significant (where it is needed to cancel the corresponding scale dependence in

the NLO log terms), it is crucial to do dynamical simulations of the (8,8) $K \rightarrow \pi$ amplitudes in order to bring under control the systematic errors due to the chiral expansion.

A. Partially quenched (8,8)'s with nondegenerate quark masses

The LEC's needed to construct the $K \rightarrow \pi\pi$, $\Delta I = 1/2$ and $3/2$ (8,8)'s can be obtained from the $K \rightarrow \pi$ amplitudes with energy insertion and $m_s \neq m_d = m_u$. The (8,8) $K \rightarrow \pi\pi$ counterterm contributions for both the $\Delta I = 3/2$ and $1/2$ amplitudes are given by

$$\langle \pi^+ \pi^- | \mathcal{O}^{(8,8),(3/2)} | K^0 \rangle_{\text{ct}} = -\frac{4i\alpha_{88}}{f_K f_\pi^2} + \frac{4i}{f_K f_\pi^2} [(-c_2^r - c_3^r - 2c_4^r - 2c_5^r - 4c_6^r)m_K^2 - (-c_1^r - c_2^r + 4c_4^r + 4c_5^r + 2c_6^r)m_\pi^2], \quad (42)$$

$$\begin{aligned} \langle \pi^+ \pi^- | \mathcal{O}^{(8,8),(1/2)} | K^0 \rangle_{\text{ct}} = & -\frac{8i\alpha_{88}}{f_K f_\pi^2} - \frac{4i}{f_K f_\pi^2} [(-c_1^r - c_2^r + 4c_4^r + 4c_5^r + 8c_6^r)m_K^2 + (-c_1^r + c_2^r + 2c_3^r + 8c_4^r + 8c_5^r \\ & + 4c_6^r)m_\pi^2]. \end{aligned} \quad (43)$$

These are the expressions in the full theory and were given by [10], where they showed that one can obtain the necessary linear combinations of LEC's from $K \rightarrow \pi$ with momentum, $\Delta I = 1/2, 3/2$. We demonstrate this holds also for the partially quenched case (without the need for 3-momentum insertion, as explained in Sec. V). In Eqs. (42) and (43) as well as all the following amplitudes, we include only the tree-level weak counterterm contributions. For clarity, the logarithmic terms and the Gasser-Leutwyler L_i counterterms have been omitted from this section but are included in Appendix D.

The $K \rightarrow \pi$ counterterm amplitudes are given by

$$\langle \pi^+ | \mathcal{O}^{(8,8),(3/2)} | K^+ \rangle_{\text{ct}} = \frac{4\alpha_{88}}{f^2} + \frac{4}{f^2} [2(c_4^r + c_5^r)m_K^2 + 2(c_4^r + c_5^r)m_\pi^2 - (c_1^r + c_2^r)m_K m_\pi + 2c_6^r N m_{SS}^2], \quad (44)$$

$$\langle \pi^+ | \mathcal{O}^{(8,8),(1/2)} | K^+ \rangle_{\text{ct}} = \frac{8\alpha_{88}}{f^2} + \frac{4}{f^2} [(6c_4^r + 4c_5^r)m_K^2 + 4(c_4^r + c_5^r)m_\pi^2 - (c_1^r - c_2^r - 2c_3^r)m_K m_\pi + 4c_6^r N m_{SS}^2]. \quad (45)$$

At this point, a practical issue in the extraction of the LEC's should be mentioned. There is a power divergence in the NLO coefficient c_4^r due to mixing with unphysical lower dimensional operators that must be removed if one is to have any hope of numerically extracting any of the LEC's. This is a problem for $K \rightarrow \pi$, $\Delta I = 1/2$, but not $K \rightarrow \pi$, $\Delta I = 3/2$, since the combination $c_4^r + c_5^r$ is finite in the continuum limit. For the $\Delta I = 1/2$ amplitude the power subtraction method of RBC [2] can be used, and this requires the $K \rightarrow 0$ amplitude. At NLO, this amplitude is

$$\langle 0 | \mathcal{O}^{(8,8)} | K^0 \rangle = \frac{4i\alpha_{88}}{f} [2A_0(m_K^2) - A_0(m_\pi^2) - A_0(m_{33}^2) + NA_0(m_{SS}^2) - NA_0(m_{uS}^2)] - \frac{8i}{f} c_4^r (m_K^2 - m_\pi^2), \quad (46)$$

where $A_0(m^2)$ is defined in Appendix A. We also mention that the (8,8), $K \rightarrow 0$ calculation has an eye diagram, and one must make a decision whether to keep the valence quarks in the eye contractions or not. The above formula, Eq. (46), corresponds to keeping the valence quarks in the eye contraction. If one neglects the type of contraction associated with Fig. 3(c), then one obtains

$$\begin{aligned} \langle 0 | \mathcal{O}^{(8,8)} | K^0 \rangle = & \frac{4i\alpha_{88}}{f} [NA_0(m_{SS}^2) - NA_0(m_{uS}^2)] \\ & - \frac{8i}{f} c_4^r (m_K^2 - m_\pi^2). \end{aligned} \quad (47)$$

Unlike the case of Q_6 , the chiral perturbation theory is not substantially changed, and one can use either method, as long as one is consistent. The $K \rightarrow 0$ subtraction works

as follows: We make use of the subtraction operator introduced in Sec. IV,

$$\Theta^{(3,\bar{3})} \equiv \bar{s}(1 - \gamma_5)d = \alpha^{(3,\bar{3})} \text{Tr}(\lambda_6 \Sigma), \quad (48)$$

to lowest order in chiral perturbation theory. The mass dependence of the above quark bilinear operator $\Theta^{(3,\bar{3})}$ is the same as that of the power divergent part of the four-quark operators, so one can use the matrix elements of this bilinear operator to subtract out power divergences to all orders in ChPT. In order to perform the subtraction at NLO for the (8,8)'s we need the following leading order expressions of the $\Theta^{(3,\bar{3})}$ amplitudes,

$$\langle \pi^+ | \Theta^{(3,\bar{3})} | K^+ \rangle = \frac{-2}{f^2} \alpha^{(3,\bar{3})}, \quad (49)$$

$$\langle 0 | \Theta^{(3,\bar{3})} | K^0 \rangle = \frac{2i}{f} \alpha^{(3,\bar{3})}. \quad (50)$$

When we take the ratio of $\langle 0 | \mathcal{O}^{(8,8)} | K^0 \rangle$ to $\langle 0 | \Theta^{(3,\bar{3})} | K^0 \rangle$ we get

$$\frac{\langle 0 | \mathcal{O}^{(8,8)} | K^0 \rangle}{\langle 0 | \Theta^{(3,\bar{3})} | K^0 \rangle} = -4 \frac{c_4^r}{\alpha^{(3,\bar{3})}} (m_K^2 - m_\pi^2) + 2 \frac{\alpha_{88}}{\alpha^{(3,\bar{3})}} (\log s) + \dots \quad (51)$$

$$\langle \pi^+ | \mathcal{O}^{(8,8),(1/2)} | K^+ \rangle + 4 \frac{c_4^r m_K^2}{\alpha^{(3,\bar{3})}} \langle \pi^+ | \Theta^{(3,\bar{3})} | K^+ \rangle = \frac{8\alpha_{88}}{f^2} (1 + \log s) + \frac{4}{f^2} [4(c_4^r + c_5^r) m_K^2 + 4(c_4^r + c_5^r) m_\pi^2 - (c_1^r - c_2^r - 2c_3^r) m_K m_\pi + 4N c_6^r m_{SS}^2]. \quad (52)$$

Here, c_4^r appears only in the linear combination $c_4^r + c_5^r$, which does not contain power divergences. Thus, the $K \rightarrow 0$ subtraction has removed the power divergences from the $\Delta I = 1/2$, $K \rightarrow \pi$ expression, including all of the higher order power divergent contributions, an important point, since the subtraction does not require (PQ)ChPT for its implementation. The expression, Eq. (52), is the one which should be fitted for the NLO LEC's. Thus, fitting to (44) and the power subtracted amplitude, (52), one can obtain all of the linear combinations needed for $K \rightarrow \pi\pi$ at NLO.

In principle, one can obtain α_{88} from either leading order term. In practice, it is safer to use the $3/2$ amplitude since the $1/2$ amplitude could receive some residual chiral symmetry breaking contribution unless one uses a discretization that has exact chiral symmetry. The $\Delta I = 3/2$ expression does not involve power divergent subtractions, and is, therefore, the best way to get the leading order coefficient. One can get c_6^r from the term that depends on the sea meson mass. From fits to the other mass combinations, one obtains $c_4^r + c_5^r$, $c_1^r + c_2^r$, and $c_1^r - c_2^r - 2c_3^r$. Along with α_{88} , the four linear combinations: $[c_1^r + c_2^r, c_1^r - c_2^r - 2c_3^r, c_4^r + c_5^r, c_6^r]$ are sufficient to determine $K \rightarrow \pi\pi$ at the physical kinematics, as one can verify with some simple algebra from Eqs. (42) and (43). When $N = 3$, the values of the LEC's determined from PQChPT are the same as in the full theory. We point out in the next subsection that one can get all of the needed information to construct the EWP matrix element for $K \rightarrow \pi\pi$ to NLO even with $K \rightarrow \pi$ using degenerate valence quark masses, along with $K \rightarrow 0$ to perform the power subtraction in the $\Delta I = 1/2$ case. The nondegenerate case remains useful, however, in that it provides additional redundancy in determining the NLO LEC's.

Note that for the cases of physical $K \rightarrow \pi\pi$ (8,8) amplitudes (42), (43), and (58) for the corresponding (8,1)'s, the pseudoscalar decay constants and masses are the physi-

cal (renormalized to one-loop order) ones. For all other amplitudes given in this paper except $K \rightarrow \pi\pi$ at physical kinematics, the formulas are in terms of the bare constants. The distinction between bare and renormalized constants is made only in tree-level amplitudes, since making this distinction in the NLO expressions introduces corrections at higher order (NNLO) than is considered here. The logarithmic and Gasser-Leutwyler counterterm contributions to the amplitudes in this section are given in Appendix D.

B. Partially Quenched (8,8)'s with degenerate quark masses for $K \rightarrow \pi$

For the case of degenerate quark masses, Eqs. (44) and (52) become

$$\langle \pi^+ | \mathcal{O}^{(8,8),(3/2)} | K^+ \rangle_{\text{ct}} = \frac{4\alpha_{88}}{f^2} + \frac{4}{f^2} [(-c_1^r - c_2^r + 4c_4^r + 4c_5^r) m^2 + 2c_6^r N m_{SS}^2], \quad (53)$$

$$\langle \pi^+ | \mathcal{O}_{\text{sub}}^{(8,8),(1/2)} | K^+ \rangle_{\text{ct}} = \frac{8\alpha_{88}}{f^2} + \frac{4}{f^2} [(-c_1^r + c_2^r + 2c_3^r + 8c_4^r + 8c_5^r) m^2 + 4c_6^r N m_{SS}^2], \quad (54)$$

where the logarithmic parts of the above expressions are given in Appendix D. The $K \rightarrow 0$ subtraction is performed exactly as in the nondegenerate case, yielding the above result, Eq. (54). Again, simple algebra will verify that the above linear combinations of LEC's are sufficient to determine the LEC combinations in Eqs. (42) and (43) for the physical (8,8) $K \rightarrow \pi\pi$ amplitudes to NLO. For example, if one subtracts the m^2 coefficient in Eq. (54) from the m^2 coefficient in Eq. (53), one gets the same linear combination as the first four terms in Eq. (42). If one wants to obtain

all the needed information in the full theory, one must do an $N = 3$ simulation, varying the sea quark mass with respect to the valence quark mass in order to determine c_6^r . That is, one must still vary the sea quark mass independently of the valence quark mass.

C. Quenched (8,8)'s with degenerate quark masses for $K \rightarrow \pi$

One can obtain results in the quenched theory by taking the $N = 0$ limit of the $K \rightarrow 0$ and degenerate $K \rightarrow \pi$ formulas. One then obtains, for $K \rightarrow 0$,

$$\langle 0 | \mathcal{O}^{(8,8)} | K^0 \rangle = \frac{4i\alpha_{88}}{f} [2A_0(m_K^2) - A_0(m_\pi^2) - A_0(m_{33}^2)] - \frac{8i}{f} c_4^r (m_K^2 - m_\pi^2). \quad (55)$$

In the quenched theory, the scale dependence of c_4^r vanishes, as one can verify from Table III. Therefore, the scale dependence of the logarithms in quenched $K \rightarrow 0$ must also vanish; the fact that it does can be seen from Eq. (55). The subtraction is performed the same way as in the partially quenched theory, and the expressions for $K \rightarrow \pi$ are

$$\langle \pi^+ | \mathcal{O}^{(8,8),(3/2)} | K^+ \rangle_{\text{ct}} = \frac{4\alpha_{88}}{f^2} \left[1 - \frac{2}{16\pi^2 f^2} \left(m^2 \ln \frac{m^2}{\mu^2} + m^2 \right) \right] + \frac{4m^2}{f^2} \left(\frac{-16\alpha_{88}}{f^2} L_5^Q - c_1^r - c_2^r + 4c_4^r + 4c_5^r \right), \quad (56)$$

$$\langle \pi^+ | \mathcal{O}_{\text{sub}}^{(8,8),(1/2)} | K^+ \rangle_{\text{ct}} = \frac{8\alpha_{88}}{f^2} \left[1 + \frac{1}{16\pi^2 f^2} \left(m^2 \ln \frac{m^2}{\mu^2} + m^2 \right) \right] + \frac{4m^2}{f^2} \left(\frac{-32\alpha_{88}}{f^2} L_5^Q - c_1^r + c_2^r + 2c_3^r + 8c_4^r + 8c_5^r \right). \quad (57)$$

Here, L_5^Q is the quenched Gasser-Leutwyler coefficient that appears in f_π . Notice that c_6^r does not appear in the quenched theory, though it does appear in $K \rightarrow \pi\pi$, where, as one can see from Table III it has a nonvanishing scale dependence. This dependence on the chiral scale leads to a large uncertainty in the NLO $K \rightarrow \pi\pi$ amplitudes, since the scale dependence of the LEC's must cancel against those of the chiral logarithms. Thus, it is essential to compute $K \rightarrow \pi$ with dynamical quarks in order to reduce the uncertainty due to the chiral expansion.

VIII. PARTIALLY QUENCHED (8,1)'S TO NLO

The amplitudes necessary to construct the physical $K \rightarrow \pi\pi$ matrix elements are $K \rightarrow 0$; $K \rightarrow \pi$, $m_s \neq m_d = m_u$; and $K \rightarrow \pi\pi$ at the unphysical kinematics points of UKX, of which UK1 and UK2 are special cases. The counterterm part of the physical (8,1) amplitude is

$$\begin{aligned} \langle \pi^+ \pi^- | \mathcal{O}^{(8,1)} | K^0 \rangle_{\text{ct}} &= \frac{4i\alpha_1}{f_K f_\pi^2} (m_K^2 - m_\pi^2)_{(1\text{-loop})} + \frac{8i}{f_K f_\pi^2} (m_K^2 - m_\pi^2) \{ (e_{10}^r - 2e_{13}^r + 2e_{14}^r + e_{15}^r) m_K^2 \\ &\quad + (-2e_1^r + 2e_{10}^r + e_{11}^r + 4e_{13}^r + e_{14}^r - 4e_2^r - 2e_3^r - 4e_{35}^r + 8e_{39}^r) m_\pi^2 \\ &\quad + \frac{8\alpha_2}{f^2} [2m_K^2 L_4 + (-4L_4 - L_5 + 8L_6 + 4L_8) m_\pi^2] \}. \end{aligned} \quad (58)$$

This differs from our previous expression [13], Eq. (35) in the appearance of a new LEC, e_{14}^r , and in the inclusion of the Gasser-Leutwyler coefficients of the amplitude previously given separately as part of the log terms in D10 of [13]. The Gasser-Leutwyler coefficients are included here with the rest of the LEC's for clarity. In the full theory the operator corresponding to this LEC can be absorbed into the other operators $\mathcal{O}_{10}^{(8,1)}$, $\mathcal{O}_{11}^{(8,1)}$, $\mathcal{O}_{12}^{(8,1)}$, and $\mathcal{O}_{13}^{(8,1)}$ via the Cayley-Hamilton theorem, as discussed in Sec. IV. Since this is no longer true in the partially quenched theory, one must obtain the constant separately. Therefore, it is left explicit in the physical amplitude.

For $K^0 \rightarrow 0$, we have

$$\langle 0 | \mathcal{O}^{(8,1)} | K^0 \rangle_{\text{ct}} = \frac{4i\alpha_2}{f} (m_K^2 - m_\pi^2) + \frac{8i}{f} (m_K^2 - m_\pi^2) [(2e_1^r - 2e_5^r) m_K^2 + e_2^r N m_{SS}^2]. \quad (59)$$

The expression for $K \rightarrow \pi$ is

$$\begin{aligned} \langle \pi^+ | \mathcal{O}^{(8,1)} | K^+ \rangle_{\text{ct}} &= \frac{4}{f^2} \alpha_1 m_K m_\pi - \frac{4}{f^2} \alpha_2 m_K^2 \\ &\quad - \frac{8}{f^2} [2(e_1^r - e_5^r) m_K^4 - 2(e_{10}^r - e_{35}^r) \\ &\quad \times m_K^3 m_\pi + (2e_3^r + 2e_5^r - 8e_{39}^r) m_K^2 m_\pi^2 \\ &\quad + (2e_{35}^r - e_{11}^r) m_K m_\pi^3 + N e_2^r m_K^2 m_{SS}^2 \\ &\quad - N e_{14}^r m_K m_\pi m_{SS}^2]. \end{aligned} \quad (60)$$

The (8,1) amplitudes have power divergent parts that must be subtracted, just as in the case of the $\Delta I = 1/2$, (8,8)'s. The subtraction is performed in the same way, but

in this case the power divergent coefficient α_2 is present already at leading order. Thus, we must consider the effects of the power subtraction at NLO if we are interested in obtaining the LEC's to this order. As we will see, the effect is to modify the NLO, (8,1) LEC's by adding terms proportional to the Gasser-Leutwyler coefficients. The LEC's modified in this way are just those that have a scale dependent part proportional to α_2 , and the new constants so obtained are given in Table V. The power subtraction eliminates the tadpole contributions from the amplitudes, and the new combinations of LEC's in Table V are free of power divergences and can be obtained in numerical fits to lattice data.

The ratio of the $K \rightarrow 0$ amplitude to the $\Theta^{(3,\bar{3})}$ $K \rightarrow 0$ amplitude to NLO in PQChPT is

$$\begin{aligned} \frac{\langle 0 | \mathcal{O}^{(8,1)} | K^0 \rangle}{\langle 0 | \Theta^{(3,\bar{3})} | K^0 \rangle} &= 2 \frac{\alpha_2}{\alpha^{(3,\bar{3})}} (m_K^2 - m_\pi^2) + 2 \frac{\alpha_1}{\alpha^{(3,\bar{3})}} (\text{logs}) + \frac{4}{\alpha^{(3,\bar{3})}} (m_K^2 - m_\pi^2) \left[2 \left(e_1^r - \frac{8\alpha_2}{f^2} L_8^r - e_5^r \right) m_K^2 \right. \\ &\quad \left. + \left(e_2^r - \frac{16\alpha_2}{f^2} L_6^r \right) N m_{SS}^2 \right]. \end{aligned} \quad (61)$$

In this case, α_2 appears multiplied by $m_K^2 - m_\pi^2$ (these are the tree-level masses, directly proportional to $m_s - m_d$), but all higher order logarithmic terms proportional to α_2 are subtracted in the ratio. Also, the NLO terms from the $\Theta^{(3,\bar{3})}$ operator appear in just the combinations given in Table V. As we will show, the effect of the subtraction on $K \rightarrow \pi$ and $K \rightarrow \pi\pi$ is to eliminate the α_2 term, including all higher order corrections proportional to α_2 , and the NLO LEC's are modified to the values in Table V, just as in the ratio for $K \rightarrow 0$. After the subtraction of $K \rightarrow \pi$, at NLO one is left with

$$\begin{aligned} \langle \pi^+ | \mathcal{O}^{(8,1)} | K^+ \rangle - 2 \frac{\alpha_2 m_K^2}{\alpha^{(3,\bar{3})}} \langle \pi^+ | \Theta^{(3,\bar{3})} | K^+ \rangle &= \frac{4\alpha_1}{f^2} m_K m_\pi (1 + \text{logs}) - \frac{8}{f^2} [2(e_{1,\text{rot}}^r - e_{5,\text{rot}}^r) m_K^4 - 2(e_{10,\text{rot}}^r - e_{35}^r) m_K^3 m_\pi \\ &\quad + (2e_{3,\text{rot}}^r + 2e_{5,\text{rot}}^r - 8e_{39}^r) m_K^2 m_\pi^2 + (2e_{35}^r - e_{11}^r) m_K m_\pi^3 \\ &\quad + N e_{2,\text{rot}}^r m_K^2 m_{SS}^2 - N e_{14}^r m_K m_\pi m_{SS}^2]. \end{aligned} \quad (62)$$

where we have indicated the coefficients that have undergone a chiral rotation to the form of Table V with a subscript, for brevity. As expected, the dependence on α_2 vanishes.

The amplitudes in the partially quenched theory for $K \rightarrow \pi\pi$ at UK1 and UK2 are

$$\langle \pi^+ \pi^- | \mathcal{O}^{(8,1)} | K^0 \rangle_{\text{ct}} = 8i \frac{\alpha_1}{f^3} m^2 + 8i \frac{m^2}{f^3} [(4e_{10}^r + 2e_{11}^r + 4e_{15}^r - 4e_{35}^r) m^2 + 2N m_{SS}^2 e_{14}^r], \quad (63)$$

for $K \rightarrow \pi\pi$, $m_K = m_\pi = m$ (UK1), and

$$\begin{aligned} \langle \pi^+ \pi^- | \mathcal{O}^{(8,1)} | K^0 \rangle_{\text{ct}} &= 4i \frac{\alpha_1}{f^3} (m_K^2 - m_\pi^2) + \frac{3i}{2} \frac{m_K^2}{f^3} [(-2e_1^r + 6e_{10}^r + e_{11}^r - 4e_{13}^r + 4e_{15}^r - 4e_2^r - 2e_3^r \\ &\quad - 4e_{35}^r + 8e_{39}^r) m_K^2 + 4e_{14}^r N m_{SS}^2] + 12i \frac{\alpha_2}{f^5} m_K^4 (4L_4 - L_5 + 8L_6 + 4L_8), \end{aligned} \quad (64)$$

for $K \rightarrow \pi\pi$, $m_{K(1\text{-loop})} = 2m_{\pi(1\text{-loop})}$ (UK2).

In the partially quenched case there are, in general, additional complications in the calculation of the $\Delta I = 1/2$, $K \rightarrow \pi\pi$ amplitudes due to threshold divergences leading to enhanced finite volume effects [23,38] which require special care. We present the logarithmic terms for the infinite volume Minkowski space amplitudes at these kinematics in Appendix E. The threshold divergences are imaginary and vanish at NLO when the sea meson mass

becomes equal to the pion mass (or in terms of quarks, $m_{\text{sea}} = m_u = m_d$) for any $N \geq 1$, see Eqs. (E3) and (E5). In infinite volume Euclidean space one might expect the imaginary part should vanish since $\mathcal{M}_{\text{Euclid}} = 1/2(\mathcal{M}_{\text{in}} - \mathcal{M}_{\text{out}})$, but in lattice calculations the imaginary part shows up in the form of enhanced finite volume effects. In finite volume Euclidean correlation functions, unless the sea masses are chosen as stated ($m_{\text{sea}} = m_u = m_d$), these enhanced finite volume effects are present, and

they diverge as a power of the lattice volume. See [22,38] for relevant calculations and discussions.⁷

As pointed out in Sec. V, there exists a set of kinematics for $K \rightarrow \pi\pi$ where the kaon and both pions are at rest, bypassing the Maiani-Testa theorem on the lattice. The quark masses (m_s and $m_u = m_d$) can be varied independently, where the weak operator inserts/removes energy to

$$\begin{aligned} \langle \pi^+ \pi^- | \mathcal{O}^{(8,1)} | K^0 \rangle_{\text{ct}} = & \frac{4i}{f^3} \alpha_1 m_\pi (m_K + m_\pi) + \frac{8i}{3f^3} \alpha_2 (m_K^2 - m_\pi^2) \frac{3m_\pi(2m_\pi - m_K) + i\epsilon}{4m_\pi(m_K - m_\pi) - i\epsilon} \\ & + \frac{16i(m_K^2 - m_\pi^2)}{3f^3[4m_\pi(m_K - m_\pi) - i\epsilon]} \{ [(4m_\pi^2 - 4m_K m_\pi + i\epsilon)(2m_K^2 + 3m_\pi^2) \\ & + 2m_K^2 m_\pi (m_K + 2m_\pi)] e_1^r + m_{SS}^2 [3(2N + 8)m_\pi^2 - 3(N + 8)m_K m_\pi + (N + 6)i\epsilon] e_2^r \\ & - 2m_K^2 (6m_\pi^2 - 3m_K m_\pi + i\epsilon) e_5^r \} + \frac{8i}{f^3} [(2e_{10}^r - 2e_{35}^r) m_K^3 m_\pi + (-2e_3^r - 4e_{13}^r + 2e_{15}^r + 2e_{35}^r \\ & + 8e_{39}^r) m_K^2 m_\pi^2 + (e_{11}^r + 2e_{15}^r) m_K m_\pi^3 + (2e_3^r + 2e_{10}^r + e_{11}^r + 4e_{13}^r - 4e_{35}^r - 8e_{39}^r) m_\pi^4 \\ & + N e_{14}^r m_K m_\pi m_{SS}^2]. \end{aligned} \quad (65)$$

When $m_K = m_\pi$, and the limit $\epsilon \rightarrow 0$ is taken in Eq. (65), we recover the special case of UK1, given by Eq. (63). One can only use UKX within the range $m_K > m_\pi$ [16], though we show that all LEC's can still be determined. The LEC contribution to UKX reduces to Eq. (66) at the special kinematics $m_K > m_\pi$ and $m_{\text{sea}} = m_u = m_d$ ($m_{SS} = m_\pi$), where the imaginary threshold divergences vanish,

$$\begin{aligned} \langle \pi^+ \pi^- | \mathcal{O}^{(8,1)} | K^0 \rangle_{\text{ct}} = & \frac{4i}{f^3} \alpha_1 m_\pi (m_K + m_\pi) + \frac{2i}{f^3} \alpha_2 (m_K + m_\pi) (2m_\pi - m_K) + \frac{8i}{f^3} [(-e_1^r + e_5^r) m_K^4 \\ & + (e_1^r - e_5^r + 2e_{10}^r - 2e_{35}^r) m_K^3 m_\pi + ((-4 - N/2)e_2^r - 2e_3^r - 2e_5^r - 4e_{13}^r + 2e_{15}^r + 2e_{35}^r + 8e_{39}^r) \\ & \times m_K^2 m_\pi^2 + ((N/2)e_2^r + e_{11}^r + N e_{14}^r + 2e_{15}^r) m_K m_\pi^3 + (2e_1^r + (4 + N)e_2^r + 2e_3^r + 2e_{10}^r + e_{11}^r \\ & + 4e_{13}^r + N e_{14}^r - 4e_{35}^r - 8e_{39}^r) m_\pi^4]. \end{aligned} \quad (66)$$

The logarithmic part of this expression is given by Eq. (E10).

The power divergent subtraction must also be performed on $K \rightarrow \pi\pi$ amplitudes, and this requires the computation of the matrix element, $\langle \pi^+ \pi^- | \Theta^{(3,\bar{3})} | K^0 \rangle$. The subtraction to be performed is

$$\begin{aligned} \langle \pi^+ \pi^- | \mathcal{O}_{\text{sub}}^{(8,1)} | K^0 \rangle \equiv & \langle \pi^+ \pi^- | \mathcal{O}^{(8,1)} | K^0 \rangle \\ & - 2 \frac{\alpha_2}{\alpha^{(3,\bar{3})}} (m_K^2 - m_\pi^2) \\ & \times \langle \pi^+ \pi^- | \Theta^{(3,\bar{3})} | K^0 \rangle, \end{aligned} \quad (67)$$

and the result of this subtraction at NLO is to eliminate the α_2 term and to transform the NLO coefficients to the form of Table V, just as in the case of the $K \rightarrow \pi$ subtraction. This is exactly what is required, since the NLO coefficients that appear in Table V always appear in the transformed

enforce 4-momentum conservation. We call this set of kinematics UKX, of which UK1 and UK2 are special cases. As pointed out by [39], there is a subtlety involved in calculating the UK1 kinematics, and the ϵ prescription must be applied. One must take the $\epsilon \rightarrow 0$ limit only after setting $m_K = m_\pi$. Given below is the most general expression for the LEC contribution to UKX,

(finite) combinations in physical quantities, such as $K \rightarrow \pi\pi$ at physical kinematics.

There is a subtlety in computing $K \rightarrow \pi\pi$ at the kinematics where $m_K = m_\pi$ (UK1) that must be considered when the matrix element of the $\Theta^{(3,\bar{3})}$ operator is computed. One expects the power divergence in $\langle \pi^+ \pi^- | \mathcal{O}^{(8,1)} | K^0 \rangle$ to vanish at $m_K = m_\pi$ by CPS arguments, as discussed in [14]. However, a naive calculation of $\langle \pi^+ \pi^- | \Theta^{(3,\bar{3})} | K^0 \rangle$ in Minkowski space shows that a factor of $m_K - m_\pi$ appears in the denominator, potentially cancelling the $m_K - m_\pi$ in the coefficient multiplying $\langle \pi^+ \pi^- | \Theta^{(3,\bar{3})} | K^0 \rangle$ in Eq. (67). This point was clarified in [39]. As they point out, it is crucial to use the ϵ prescription in order to have a well-defined Minkowski space amplitude. The $\epsilon \rightarrow 0$ limit must be taken after the $m_K \rightarrow m_\pi$ limit. Thus, at leading order in ChPT, the $K \rightarrow \pi\pi$ amplitude for the $\Theta^{(3,\bar{3})}$ operator at UK1 is

$$\begin{aligned} \langle \pi^+ \pi^- | \Theta^{(3,\bar{3})} | K^0 \rangle = & \lim_{\epsilon \rightarrow 0} \left[\lim_{m_K \rightarrow m_\pi} \frac{4i\alpha^{(3,\bar{3})}}{3f^3} \right. \\ & \left. \times \frac{3m_\pi(2m_\pi - m_K) + i\epsilon}{4m_\pi(m_K - m_\pi) - i\epsilon} \right]. \end{aligned} \quad (68)$$

⁷Reference [16] states that in partially quenched lattice calculations, unless the unphysical degrees of freedom are above the two pion threshold, one may have serious problems with the enhanced finite volume effects. Again, see the note added in revision.

As one can see from Eq. (68) after taking the first limit, there is a pole at this kinematics. This pole in the denominator comes about from the graph of Fig. 1(C)2, where the kaon is annihilated by the tadpole operator. As discussed by [39], it is useful to consider the corresponding amplitude in finite volume Euclidean space. In this case, the divergence is regulated by the finite time extent of the lattice, and the amplitude becomes proportional to t_π (to LO in ChPT), which is the difference in time between the weak operator insertion and the two pion sink. When one multiplies $\langle \pi^+ \pi^- | \Theta^{(3,\bar{3})} | K^0 \rangle$ by $m_K^2 - m_\pi^2$ at exactly $m_K = m_\pi$, then the contribution from the $\Theta^{(3,\bar{3})}$ term in Eq. (67) is identically zero, and the power divergence vanishes at $m_K = m_\pi$, as expected from CPS symmetry. In the previous version of this paper, as well as in [13], we did not properly appreciate this subtlety; we correct Eqs. (31) and (D6) of [13] in Appendix F.

The subtraction is necessary in UKX at all accessible values of the meson masses except UK1, as discussed above,⁸ and at $m_K = 2m_\pi$ (UK2) because then there is no 4-momentum insertion at the weak vertex. To the extent that one cannot set m_K exactly equal to $2m_\pi$ on the lattice, it becomes necessary to perform a small subtraction at this kinematics. Since the power divergences in UKX are proportional to $m_K - 2m_\pi$ [Eqs. (65) and (E10)], the best place to investigate UKX numerically is in the vicinity of $m_K = 2m_\pi$, where we hope the power divergences will not be intractable.

The NLO LEC's for the (8,1) case can be obtained as follows: From the subtracted $K \rightarrow \pi$ amplitude, Eq. (62), one can obtain the leading order LEC, α_1 . If one uses the LEC combinations obtainable from Eq. (61) for $K \rightarrow 0$, $e_{2,\text{rot}}^r$ and $e_{1,\text{rot}}^r - e_{5,\text{rot}}^r$, one can also obtain from Eq. (62): $e_{1,\text{rot}}^r + e_{3,\text{rot}}^r - 4e_{39}^r$, $e_{10,\text{rot}}^r - e_{35}^r$, $2e_{10,\text{rot}}^r - e_{11}^r$, and e_{14}^r . Using this information along with the linear combinations one can get from Eq. (66) (after the subtraction) it is possible to obtain $e_{11} + 2e_{15,\text{rot}}$ and $e_{13,\text{rot}}$. Notice that UKX provides additional redundancy over that of UK1 and UK2 alone. For the construction of the physical $K \rightarrow \pi\pi$ amplitude we need these seven linear combinations: $[e_{2,\text{rot}}^r, e_{1,\text{rot}}^r + e_{3,\text{rot}}^r - 4e_{39}^r, e_{10,\text{rot}}^r - e_{35}^r, 2e_{10,\text{rot}}^r - e_{11}^r - e_{14}^r, e_{11} + 2e_{15,\text{rot}}, e_{13,\text{rot}}, e_{14}]$. One can verify that with these linear combinations it is possible to obtain the linear combinations in Eq. (58).

The logarithmic and Gasser-Leutwyler counterterm contributions to the amplitudes presented in this section are given in Appendix E.

IX. CHECKS OF THE CALCULATIONS

The logarithmic terms in the appendices of this paper are rather lengthy, and so checks are important. The first check these expressions must pass is that the divergences from

the one-loop insertions cancel those of the divergent counterterms. This was checked for all expressions in this paper. Another check is that an expression reduces to some other in the appropriate limit. For example, in the SU(3) limit, the equations in Appendix C reduce to those of [11] in the same limit, as well as those of [30], modulo renormalization scheme dependent constants. That is, the logarithmic terms agree, but the scheme dependent m^4 coefficients differ.

The $K \rightarrow \pi\pi$ amplitudes in the full theory for the (8,8)'s in Appendix D agree with Pallante, *et al.* [40], as well as with [10] (where only numerical values were given). Also, the PQ, $K \rightarrow \pi$ amplitudes of Appendix D for the (8,8)'s agree with [10] when they reduce to those of the full theory, in the SU(3) limit with $m_{\text{sea}} = m_{\text{val}}$. In the partially quenched theory, [21] has done $K^+ \rightarrow \pi^+$ in the SU(3) limit. By taking the appropriate linear combinations of the $\Delta I = 3/2$ and $1/2$ amplitudes given in Appendix D we can compare to this special case, where we find agreement. In Appendix E, Eq. (E1) [PQ $K \rightarrow 0$ for the (8,1)'s] can be compared directly with [30], where it agrees to within renormalization scheme dependent constants. Equation (E2) [PQ $K \rightarrow \pi$ for the (8,1)'s] also agrees with [30] in the SU(3) limit modulo the renormalization scheme dependent constants. Equation (E3), $K \rightarrow \pi\pi$ at UK1, reduces to that of the full theory for $m_{SS} = m$, $N = 3$ and can be compared with our previous paper [13]. Note, however, there is an error in this quantity in [13] which has been corrected in Appendix F of this paper. Equation (E5), $K \rightarrow \pi\pi$ at UK2, does not reduce to that of the full theory since $m_s \neq m_d = m_u$, but the sea quarks were taken to be degenerate. Note that the logarithmic parts of the α_2 term vanish for this on shell quantity just as in the full theory.

X. CONCLUSION

This paper demonstrates that all of the ingredients necessary to construct all of the $K \rightarrow \pi\pi$ amplitudes to NLO in the full theory can be obtained without 3-momentum insertion on the lattice, which reduces the computational cost of obtaining the NLO LEC's; all that is necessary in the needed $K \rightarrow \pi$ amplitudes is the use of nondegenerate quark masses such that $m_K^{\text{lat}} \neq m_\pi^{\text{lat}}$. It was also demonstrated that all of the ingredients needed to produce ϵ'/ϵ to NLO are obtainable from partially quenched ChPT. In the case that $N = 3$, the LEC's are those of the full theory [20].⁹ The partially quenched amplitudes were calculated under the assumption that both the valence and sea quark masses are small compared to the η' mass so that the η' can

⁸Note that UK1 is only accessible in the full theory [16].

⁹By studying finite volume Euclidean Green's functions in PQChPT, [16] confirmed that one can use the partially quenched theory for $\Delta I = 1/2$, $K \rightarrow \pi\pi$ amplitudes for $N = 2$, and our choice for the sea quark mass, $m_{\text{sea}} = m_{u,d}$. However, enhanced finite volume effects are present in the $N = 3$ case unless the sea quark masses are pairwise equal to the valence quark masses, such that one is in the full theory.

be integrated out. This means that the $N = 0$ limit of our amplitudes are not those of the quenched approximation, and this has been discussed elsewhere [30]. (The terms inversely proportional to powers of N become quenched chiral logs.) We point out that we are using the PQS method [36], where only the sea quarks propagate in the loops of Fig. 3(c) (see Sec. VIA for the correspondence between Fig. 3(c) and the traditional form of the eye diagrams in Fig. 2 for the various operators), and that the necessary ingredients to obtain the (8,1)'s are essentially unchanged from [13] in this prescription.¹⁰ The PQN method, however, may not be adequate to determine the LEC's to NLO using only the ingredients needed of the full theory, except in the case where it becomes the full theory ($N = 3$, $m_{\text{sea}} = m_{\text{val}}$).

The PQChPT formulas in this paper are valid for $N = 2$, however, and this should be useful for the work in progress by RBC with $N = 2$ dynamical flavors of domain wall quarks [41], though the values of the LEC's determined from these calculations will not necessarily be those of the full theory. One would hope, of course, that the N dependence will not be so severe, and that this calculation will not be so far from the full theory. Ultimately, one would like to check this with a full $N = 3$ calculation.

We show how the bilinear $(3, \bar{3})$ operator is used to eliminate the power divergences due to mixing with lower dimensional operators to all orders in (PQ)ChPT for the $\Delta I = 1/2$ amplitudes. The subtraction is performed to all orders in ChPT [2]. This is important, because the higher order power divergent parts can overwhelm the physical terms one is trying to calculate.

We have pointed out that the (8,8) $K \rightarrow \pi\pi$ amplitudes can be constructed to NLO using only partially quenched $K \rightarrow \pi$ amplitudes with degenerate valence quark masses and without momentum insertion. Also, we showed how $K \rightarrow 0$ can be used to perform the $\Delta I = 1/2$ power divergent subtraction. $K \rightarrow \pi$ calculations with nondegenerate valence quark masses would provide additional redundancy in obtaining the needed NLO LEC's.

Finally, we point out that the threshold divergences that lead to enhanced finite volume corrections to the lattice calculations of $\Delta I = 1/2$, $K \rightarrow \pi\pi$ amplitudes at NLO vanish in the Minkowski space amplitudes considered in this paper when the sea quark mass is equal to the up and down quark masses ($m_{\text{sea}} = m_u = m_d$). This conclusion remains true in the $N = 2$ case for the finite volume Euclidean correlation functions that are relevant for lattice simulations, as demonstrated by [16]. The $N = 3$ case had been shown to be problematic due to the presence of enhanced finite volume effects unless one is working in the full theory, with all sea quark masses equal to the

corresponding valence quark masses [16]. See the note added in revision for further discussion of this issue.

ACKNOWLEDGMENTS

This research was supported in part by U.S. DOE Contract No. DE-AC02-98CH10886. We thank Tom Blum, Chris Dawson, Maarten Golterman, David Lin, and Kim Splittorff for discussions.

Noted added in revision.—Since the original posting of version one of this paper on the preprint archive, Lin, *et al.* [16] have submitted a paper motivated at least in part by our version one. They have done a calculation of the relevant finite volume Euclidean correlation functions, and they have made several important observations regarding our attempts to obtain $K \rightarrow \pi\pi$ amplitudes at NLO, which we briefly review, and then we make some comments. They point out that the case of the $\Delta I = 1/2$ $K \rightarrow \pi\pi$ amplitudes at degenerate quark masses (what we call UK1), has difficulties in the full theory, and is intractable in the partially quenched theory, even at our special kinematics, $m_{\text{sea}} = m_{u,d}$.

The difficulty with UK1 in the full theory is that one must disentangle various two meson final states in order to obtain the two pion final state. These two meson states have different energies, and since they appear in the correlation function with different exponentials in time, they will be difficult to obtain. See [16] for further details. They have also discovered that when unphysical degrees of freedom propagating in the meson re-scattering diagram are light enough to go on shell, they cause enhanced finite volume effects, which cannot be eliminated by going to larger lattices, and they make the extraction of such amplitudes impossible in the infinite volume limit. This problem afflicts the $\Delta I = 1/2$ $K \rightarrow \pi\pi$ amplitudes for degenerate quark masses (UK1) in the partially quenched theory, and so it cannot be used in our attempts to get the LEC's to NLO.

However, it also was pointed out in [16] that the enhanced finite volume effects do vanish when the unphysical degrees of freedom are heavier than the light quark mass. This leads to the conclusion that when one is working at UKX (initial and final mesons at rest) if m_K is strictly greater than m_π , assuming also $m_{\text{sea}} = m_{u,d}$ and $N = 2$, the enhanced finite volume effects vanish. Thus UK2 ($m_K = 2m_\pi$), and the kinematics points of UKX (with $m_K > m_\pi$) are useable in the partially quenched theory. Also, they point out that since the unphysical degrees of freedom cannot be lighter than the light quark mass, if one is working in the $N = 3$ theory, one must use full QCD. That is, the idea of varying the sea and valence quark masses independently [20] will not work for $\Delta I = 1/2$, $K \rightarrow \pi\pi$ amplitudes without introducing enhanced finite volume effects.

As discussed in [16], it is not possible to use UK1 in order to obtain some of the NLO LEC's in the partially

¹⁰The only change is that instead of UK1, one may need to use UKX, as the former has difficulties which were pointed out by [16]. See also our note added in revision.

quenched case. We suggest that there may be a window where the quark masses are light enough and the lattice size is small enough so that the formulas of finite volume partially quenched ChPT can be used to extract LEC's from numerical data. Whether or not this proves feasible, we have found that we do not need the information from UK1 if we use the $K \rightarrow \pi\pi$ kinematics accessible to the lattice that we call UKX. We have presented results at UKX (all three mesons at rest, in general, requiring energy insertion with $m_K \geq m_\pi$) in Sec. VIII, of which UK1 and UK2 are special cases. According to [16], there will not be enhanced finite volume effects at this kinematics (when $N = 2$, $m_{\text{sea}} = m_{u,d}$ and $m_K > m_\pi$), though, in general, one will need to do the power divergent subtractions, as in the $K \rightarrow \pi$ case. We demonstrated in Sec. VIII that one can obtain all of the LEC's needed for the (8,1), $K \rightarrow \pi\pi$ amplitudes using the UKX kinematics points, along with the LEC's obtainable from $K \rightarrow 0$ and $K \rightarrow \pi$. We conclude that it is possible to obtain all of the needed LEC's in the partially quenched theory for $N = 2$, though, as noted by [16], a $N = 3$ determination will require the full theory

for the information needed from lattice (8,1), $K \rightarrow \pi\pi$ amplitudes in order to avoid the enhanced finite volume effects.

APPENDIX A

Appendices B, C, D, and E contain the finite logarithm and Gasser-Leutwyler counterterm contributions to the amplitudes presented in this paper. They were calculated using the FEYNALC package [42] written for the Mathematica [43] system. These expressions involve the regularized Veltman-Passarino basis integrals A_0 , B_0 , and C_0 [44]:

$$A_0(m^2) = \frac{1}{16\pi^2 f^2} m^2 \ln \frac{m^2}{\mu^2}, \quad (\text{A1})$$

$$B_0(q^2, m_1^2, m_2^2) = \int_0^1 dx \frac{1}{(4\pi f)^2} [1 + \ln(-x(1-x)q^2 + xm_1^2 + (1-x)m_2^2) - \ln \mu^2], \quad (\text{A2})$$

$$C_0(0, q^2, q^2, m_1^2, m_1^2, m_2^2) = \frac{1}{(4\pi f)^2} \int_0^1 dx \frac{x}{-x(1-x)q^2 + xm_1^2 + (1-x)m_2^2}. \quad (\text{A3})$$

Note that the original Veltman-Passarino integrals did not involve ChPT, and so the pseudoscalar decay-constant f is not part of the original definitions of the integrals but is inserted here for convenience.

APPENDIX B

At one-loop order in the partially quenched theory the pseudoscalar decay constants and masses are renormalized such that $f_{\pi,K} = f(1 + \frac{\Delta f_{\pi,K}}{f})$ and $m_{\pi,K(1\text{-loop})}^2 = m_{\pi,K}^2(1 + \frac{\Delta m_{\pi,K}^2}{m_{\pi,K}^2})$. The corrections are

$$\frac{\Delta f_\pi}{f} = -NA_0(m_{us}^2) + \frac{8}{f^2}(L_5 m_\pi^2 + L_4 N m_{SS}^2), \quad (\text{B1})$$

$$\begin{aligned} \frac{\Delta f_K}{f} &= \frac{1}{N16\pi^2 f^2} (m_K^2 - m_{SS}^2) - \frac{m_\pi^4 + m_K^2(m_{SS}^2 - 2m_\pi^2)}{2N(m_K^2 - m_\pi^2)} \left[\frac{1}{m_\pi^2} A_0(m_\pi^2) - \frac{1}{m_{33}^2} A_0(m_{33}^2) \right] - \frac{N}{2} (A_0(m_{us}^2) + A_0(m_{SS}^2)) \\ &+ \frac{8}{f^2} (L_5 m_K^2 + L_4 N m_{SS}^2), \end{aligned} \quad (\text{B2})$$

$$\frac{\Delta m_\pi^2}{m_\pi^2} = \frac{2}{N} \left[\frac{1}{16\pi^2 f^2} (-m_{SS}^2 + m_\pi^2) + \frac{2m_\pi^2 - m_{SS}^2}{m_\pi^2} A_0(m_\pi^2) \right] - \frac{16}{f^2} [(L_5 - 2L_8)m_\pi^2 + (L_4 - 2L_6)N m_{SS}^2], \quad (\text{B3})$$

$$\frac{\Delta m_K^2}{m_K^2} = \frac{-1}{N(m_K^2 - m_\pi^2)} [(m_\pi^2 - m_{SS}^2)A_0(m_\pi^2) + (-2m_K^2 + m_\pi^2 + m_{SS}^2)A_0(m_{33}^2)] - \frac{16}{f^2} [(L_5 - 2L_8)m_K^2 + (L_4 - 2L_6)N m_{SS}^2]. \quad (\text{B4})$$

For degenerate quark masses at one-loop order, $m_{K(1\text{-loop})}^2 = m_{\pi(1\text{-loop})}^2 = m^2(1 + \frac{\Delta m^2}{m^2})$, $f_\pi = f_K = f(1 + \frac{\Delta f}{f})$,

$$\frac{\Delta m^2}{m^2} = \frac{2}{N} \left[\frac{m^2 - m_{SS}^2}{16\pi^2 f^2} + \frac{2m^2 - m_{SS}^2}{m^2} A_0(m^2) \right] - \frac{16}{f^2} [(L_5 - 2L_8)m^2 + (L_4 - 2L_6)N m_{SS}^2], \quad (\text{B5})$$

$$\frac{\Delta f}{f} = -NA_0(m_{us}^2) + \frac{8}{f^2} (L_5 m^2 + L_4 N m_{SS}^2), \quad (\text{B6})$$

with $m_{vS}^2 = \frac{1}{2}(m^2 + m_{3S}^2)$.

APPENDIX C: LOG CORRECTIONS TO FULL CHPT

The logarithmic corrections to the $K \rightarrow \pi$ amplitudes in the full theory when 3-momentum insertion vanishes are

$$\begin{aligned} \langle \pi^+ | \mathcal{O}^{(27,1),(3/2)} | K^+ \rangle_{\log} = & -\frac{4\alpha_{27}}{f^2} m_K m_\pi \left[-2m_K m_\pi B_0(q^2, m_K^2, m_\pi^2) - \frac{3}{2}A_0(m_\eta^2) - 7A_0(m_K^2) - \frac{15}{2}A_0(m_\pi^2) - \frac{\Delta f_K}{f} \right. \\ & \left. - \frac{\Delta f_\pi}{f} + \frac{1}{2} \left(\frac{\Delta m_K^2}{m_K^2} + \frac{\Delta m_\pi^2}{m_\pi^2} \right) \right], \end{aligned} \quad (C1)$$

$$\begin{aligned} \langle \pi^+ | \mathcal{O}^{(27,1),(1/2)} | K^+ \rangle_{\log} = & -\frac{4\alpha_{27}}{f^2} m_K m_\pi \left[-(4m_K^2 + 6m_K m_\pi - 4m_\pi^2)B_0(q^2, m_K^2, m_\pi^2) + 4m_K m_\pi B_0(q^2, m_K^2, m_\pi^2) \right. \\ & + \frac{3(4m_K^2 - 3m_K m_\pi + 2m_\pi^2)}{2m_\pi(m_K - m_\pi)} A_0(m_\eta^2) - \frac{6m_K^2 + 10m_K m_\pi - 10m_\pi^2}{m_\pi(m_K - m_\pi)} A_0(m_K^2) \\ & \left. - \frac{3(m_K - 2m_\pi)}{2(m_K - m_\pi)} A_0(m_\pi^2) - \frac{\Delta f_K}{f} - \frac{\Delta f_\pi}{f} + \frac{1}{2} \left(\frac{\Delta m_K^2}{m_K^2} + \frac{\Delta m_\pi^2}{m_\pi^2} \right) \right], \end{aligned} \quad (C2)$$

$$\begin{aligned} \langle \pi^+ | \mathcal{O}^{(8,1)} | K^+ \rangle_{\log} = & \frac{4\alpha_1}{f^2} m_K m_\pi \left[\frac{1}{9}(4m_K^2 + 6m_K m_\pi - 4m_\pi^2)B_0(q^2, m_K^2, m_\pi^2) + 4m_K m_\pi B_0(q^2, m_K^2, m_\pi^2) \right. \\ & - \frac{4m_K^2 + 7m_K m_\pi - 8m_\pi^2}{6m_\pi(m_K - m_\pi)} A_0(m_\eta^2) - \frac{3m_K^2 + 5m_K m_\pi - 5m_\pi^2}{3m_\pi(m_K - m_\pi)} A_0(m_K^2) - \frac{3(m_K - 2m_\pi)}{2(m_K - m_\pi)} A_0(m_\pi^2) \\ & \left. - \frac{\Delta f_K}{f} - \frac{\Delta f_\pi}{f} + \frac{1}{2} \left(\frac{\Delta m_K^2}{m_K^2} + \frac{\Delta m_\pi^2}{m_\pi^2} \right) \right] - \frac{4\alpha_2}{f^2} m_K^2 \left[\frac{2}{3} m_K m_\pi B_0(q^2, m_K^2, m_\pi^2) \right. \\ & + 4m_K m_\pi B_0(q^2, m_K^2, m_\pi^2) - \frac{5m_K - 2m_\pi}{6(m_K - m_\pi)} A_0(m_\eta^2) - \frac{3m_K - 2m_\pi}{m_K - m_\pi} A_0(m_K^2) \\ & \left. - \frac{3m_K - 6m_\pi}{2(m_K - m_\pi)} A_0(m_\pi^2) - \frac{\Delta f_K}{f} - \frac{\Delta f_\pi}{f} \right]. \end{aligned} \quad (C3)$$

These are the simplified versions of [13], Eqs. (C2), (D3), and (D4), respectively, when $q^2 = (m_K - m_\pi)^2$.

APPENDIX D: PQ LOG CORRECTIONS TO (8,8)'S

The logarithmic corrections for the (8,8) amplitudes relevant for the determination of $K \rightarrow \pi\pi$ are given in this section. The logarithmic corrections to $K \rightarrow \pi\pi$ in the full theory were calculated first in [10,40] and are included here for completeness:

$$\begin{aligned} \langle \pi^+ \pi^- | \mathcal{O}^{(8,8),(3/2)} | K^0 \rangle_{\log} = & -4i \frac{\alpha_{88}}{f_K f_\pi^2} \left[\left(\frac{5m_K^4}{4m_\pi^2} - 2m_K^2 \right) B_0(m_\pi^2, m_K^2, m_\pi^2) + (m_K^2 - 2m_\pi^2) B_0(m_K^2, m_\pi^2, m_\pi^2) \right. \\ & \left. + \frac{m_K^4}{4m_\pi^2} B_0(m_\pi^2, m_K^2, m_\pi^2) - \left(4 + \frac{m_K^2}{2m_\pi^2} \right) A_0(m_K^2) + \left(\frac{5m_K^2}{4m_\pi^2} - 8 \right) A_0(m_\pi^2) - \frac{3m_K^2}{4m_\pi^2} A_0(m_\eta^2) \right], \end{aligned} \quad (D1)$$

$$\begin{aligned} \langle \pi^+ \pi^- | \mathcal{O}^{(8,8),(1/2)} | K^0 \rangle_{\log} = & -8i \frac{\alpha_{88}}{f_K f_\pi^2} \left[\left(\frac{m_K^4}{2m_\pi^2} - 2m_K^2 \right) B_0(m_\pi^2, m_K^2, m_\pi^2) + \frac{3}{4} m_K^2 B_0(m_K^2, m_K^2, m_K^2) \right. \\ & + (m_\pi^2 - 2m_K^2) B_0(m_K^2, m_\pi^2, m_\pi^2) + \frac{m_K^4}{4m_\pi^2} B_0(m_\pi^2, m_K^2, m_\pi^2) + \frac{1}{4} \left(\frac{m_K^2}{m_\pi^2} - 22 \right) A_0(m_K^2) \\ & \left. + \frac{1}{4} \left(\frac{2m_K^2}{m_\pi^2} - 26 \right) A_0(m_\pi^2) - \frac{3m_K^2}{4m_\pi^2} A_0(m_\eta^2) \right]. \end{aligned} \quad (D2)$$

The $\Delta I = 3/2$, $K \rightarrow \pi$ logarithmic corrections are given by

$$\begin{aligned}
 \langle \pi^+ | \mathcal{O}^{(8,8),(3/2)} | K^+ \rangle_{\log} &= \frac{4\alpha_{88}}{f^2} \left[-2m_K m_\pi B_0(q^2, m_K^2, m_\pi^2) - N(A_0(m_{SS}^2) + 3A_0(m_{uS}^2)) + \frac{m_\pi^4 + m_K^2(m_{SS}^2 - 2m_\pi^2)}{N(2m_K^4 - 3m_K^2 m_\pi^2 + m_\pi^4)} A_0(m_{33}^2) \right. \\
 &\quad \left. + \frac{m_\pi^4 + m_K^2(m_{SS}^2 - 2m_\pi^2)}{Nm_\pi^2(m_\pi^2 - m_K^2)} A_0(m_\pi^2) + \frac{2}{N16\pi^2 f^2} (m_K^2 - m_{SS}^2) - \frac{\Delta f_K}{f} - \frac{\Delta f_\pi}{f} \right]. \quad (D3)
 \end{aligned}$$

For the $\Delta I = 1/2$, $K \rightarrow \pi$ corrections there are (at least) two possibilities, when the electro-weak operator is partially quenched and when it is not. The following amplitude corresponds to quenching the short distance electro-weak operator, neglecting the type of contraction in Fig. 3(c) (with a photon or Z replacing the gluon),

$$\begin{aligned}
 \langle \pi^+ | \mathcal{O}^{(8,8),(1/2)} | K^+ \rangle_{\log} &= \frac{8\alpha_{88}}{f^2} \left[m_K m_\pi B_0(q^2, m_K^2, m_\pi^2) + Nm_K m_\pi B_0(q^2, m_{uS}^2, m_{sS}^2) + \frac{N(2m_\pi - 3m_K)}{2(m_K - m_\pi)} A_0(m_{sS}^2) \right. \\
 &\quad + \frac{N(6m_\pi - 5m_K)}{2(m_K - m_\pi)} A_0(m_{uS}^2) + \frac{m_\pi^4 + m_K^2(m_{SS}^2 - 2m_\pi^2)}{N(2m_K^4 - 3m_K^2 m_\pi^2 + m_\pi^4)} A_0(m_{33}^2) \\
 &\quad \left. + \frac{m_\pi^4 + m_K^2(m_{SS}^2 - 2m_\pi^2)}{Nm_\pi^2(m_\pi^2 - m_K^2)} A_0(m_\pi^2) + \frac{2}{N16\pi^2 f^2} (m_K^2 - m_{SS}^2) - \frac{\Delta f_K}{f} - \frac{\Delta f_\pi}{f} \right], \quad (D4)
 \end{aligned}$$

while the next corresponds to where the short distance electro-weak operator is not quenched, and valence quarks do propagate in the loops of Fig. 3(c) (again with a photon or Z replacing the gluon)

$$\begin{aligned}
 \langle \pi^+ | \mathcal{O}^{(8,8),(1/2)} | K^+ \rangle_{\log} &= \frac{8\alpha_{88}}{f^2} \left[2m_K m_\pi B_0(q^2, m_K^2, m_\pi^2) - m_K m_\pi B_0(q^2, m_K^2, m_{33}^2) + Nm_K m_\pi B_0(q^2, m_{uS}^2, m_{sS}^2) \right. \\
 &\quad + \frac{N(2m_\pi - 3m_K)}{2(m_K - m_\pi)} A_0(m_{sS}^2) + \frac{N(6m_\pi - 5m_K)}{2(m_K - m_\pi)} A_0(m_{uS}^2) + \left(\frac{m_\pi^4 + m_K^2(m_{SS}^2 - 2m_\pi^2)}{N(2m_K^4 - 3m_K^2 m_\pi^2 + m_\pi^4)} \right. \\
 &\quad \left. + \frac{m_K}{2(m_K - m_\pi)} \right) A_0(m_{33}^2) + \left(\frac{m_\pi^4 + m_K^2(m_{SS}^2 - 2m_\pi^2)}{Nm_\pi^2(m_\pi^2 - m_K^2)} + \frac{m_K}{2(m_K - m_\pi)} \right) A_0(m_\pi^2) \\
 &\quad \left. + \frac{m_K}{m_\pi - m_K} A_0(m_K^2) + \frac{2}{N16\pi^2 f^2} (m_K^2 - m_{SS}^2) - \frac{\Delta f_K}{f} - \frac{\Delta f_\pi}{f} \right]. \quad (D5)
 \end{aligned}$$

In the case of degenerate valence quarks the above expressions reduce to

$$\langle \pi^+ | \mathcal{O}^{(8,8),(3/2)} | K^+ \rangle_{\log} = \frac{4\alpha_{88}}{f^2} \left\{ \frac{-2}{16\pi^2 f^2} \left[m^2 \ln \frac{m^2}{\mu^2} + N(m^2 + m_{SS}^2) \ln \left(\frac{m^2 + m_{SS}^2}{2\mu^2} \right) + m^2 \right] - \frac{2\Delta f}{f} \right\}, \quad (D6)$$

$$\langle \pi^+ | \mathcal{O}^{(8,8),(1/2)} | K^+ \rangle_{\log} = \frac{8\alpha_{88}}{f^2} \left\{ \frac{1}{16\pi^2 f^2} \left[m^2 \ln \frac{m^2}{\mu^2} - 2N(m^2 + m_{SS}^2) \ln \left(\frac{m^2 + m_{SS}^2}{2\mu^2} \right) + m^2 \right] - \frac{2\Delta f}{f} \right\}. \quad (D7)$$

Note that the two $\Delta I = 1/2$ expressions reduce to the same thing in the SU(3) limit.

APPENDIX E: PQ LOG CORRECTIONS TO (8,1)'S

The logarithmic corrections for the quantities relevant for the determination of the (8,1), $K \rightarrow \pi\pi$ amplitudes are given here. The logarithmic corrections to the physical $K \rightarrow \pi\pi$ amplitude have been done by [28,29], and we refer to [13], Eq. D10, for the amplitude in our conventions.

The logarithmic corrections to $K \rightarrow 0$ and $K \rightarrow \pi$ are given by

$$\begin{aligned}
 \langle 0 | \mathcal{O}^{(8,1)} | K^0 \rangle_{\log} &= \frac{4i\alpha_2}{f} (m_K^2 - m_\pi^2) \left[-N(A_0(m_{sS}^2) + A_0(m_{uS}^2)) + \frac{-4m_K^2 + 2m_\pi^2 + m_{SS}^2}{N(m_\pi^2 - 2m_K^2)} A_0(m_{33}^2) \right. \\
 &\quad \left. + \frac{2m_\pi^2 - m_{SS}^2}{Nm_\pi^2} A_0(m_\pi^2) - \frac{2(m_{SS}^2 - m_K^2)}{N16\pi^2 f^2} - \frac{\Delta f_K}{f} \right] + \frac{4i\alpha_1}{f} \left[\frac{-2(m_K^2 - m_\pi^2)(2m_K^2 - m_{SS}^2)}{N16\pi^2 f^2} + N(m_{sS}^2 A_0(m_{sS}^2) \right. \\
 &\quad \left. - m_{uS}^2 A_0(m_{uS}^2)) + \frac{1}{N} (3m_\pi^2 - 2m_{SS}^2) A_0(m_\pi^2) + \frac{1}{N} (2m_{SS}^2 - 3m_{33}^2) A_0(m_{33}^2) \right], \quad (E1)
 \end{aligned}$$

$$\begin{aligned}
\langle \pi^+ | \mathcal{O}^{(8,1)} | K^+ \rangle_{\log} &= \frac{4\alpha_1}{f^2} m_K m_\pi \left[\frac{4m_K^3 + 4m_K^2 m_\pi - 2m_K m_{SS}^2 + m_\pi^3 - 3m_\pi m_{SS}^2}{N16\pi^2 f^2 m_\pi} - \frac{2}{N} (m_K^2 + m_K m_\pi - m_\pi^2) \right. \\
&\times (2m_K^2 - m_\pi^2 - m_{SS}^2) C_0(0, q^2, q^2, m_{33}^2, m_{33}^2, m_K^2) + \frac{1}{N(m_K^2 - m_\pi^2)} (-6m_K^4 - 4m_K^3 m_\pi + 10m_K^2 m_\pi^2 \\
&+ 3m_K m_\pi^3 - 4m_\pi^4 + (2m_K^2 + m_K m_\pi - 2m_\pi^2) m_{SS}^2) B_0(q^2, m_K^2, m_{33}^2) \\
&+ \frac{m_K m_\pi (m_\pi^2 - m_{SS}^2)}{N(m_K^2 - m_\pi^2)} B_0(q^2, m_K^2, m_\pi^2) + N(-m_\pi^2 + 2m_K m_\pi + m_{SS}^2) B_0(q^2, m_{SS}^2, m_{uS}^2) \\
&- \frac{N(2m_K^2 - m_\pi^2 + m_{SS}^2)}{2m_\pi(m_K - m_\pi)} A_0(m_{SS}^2) + \frac{N(3m_\pi^2 - 2m_K m_\pi + m_{SS}^2)}{2m_\pi(m_K - m_\pi)} A_0(m_{uS}^2) \\
&- \frac{-12m_K^3 - 6m_K^2 m_\pi + 6m_K m_\pi^2 + 4m_K m_{SS}^2 + 3m_\pi^3 + m_\pi m_{SS}^2}{2Nm_\pi(m_K^2 - m_\pi^2)} A_0(m_{33}^2) \\
&+ \frac{1}{2Nm_\pi^2(m_K^2 - m_\pi^2)} (-7m_\pi^4 - 6m_K m_\pi^3 + 4m_K^2 m_\pi^2 + 3m_\pi^2 m_{SS}^2 + 4m_K m_\pi m_{SS}^2 - 2m_K^2 m_{SS}^2) \\
&\times A_0(m_\pi^2) - \frac{2}{N} A_0(m_K^2) - \frac{\Delta f_K}{f} - \frac{\Delta f_\pi}{f} + \frac{1}{2} \left(\frac{\Delta m_K^2}{m_K^2} + \frac{\Delta m_\pi^2}{m_\pi^2} \right) \left. \right] \\
&- \frac{4\alpha_2}{f^2} m_K^2 \left[\frac{2}{N16\pi^2 f^2} (m_K^2 + m_K m_\pi + m_\pi^2 - m_{SS}^2) + \frac{2}{N} m_K m_\pi (-2m_K^2 + m_\pi^2 + m_{SS}^2) \right. \\
&\times C_0(0, q^2, q^2, m_{33}^2, m_{33}^2, m_K^2) + \frac{m_K m_\pi (-4m_K^2 + 3m_\pi^2 + m_{SS}^2)}{N(m_K^2 - m_\pi^2)} B_0(q^2, m_K^2, m_{33}^2) \\
&+ \frac{m_K m_\pi (m_\pi^2 - m_{SS}^2)}{N(m_K^2 - m_\pi^2)} B_0(q^2, m_K^2, m_\pi^2) + 2Nm_K m_\pi B_0(q^2, m_{SS}^2, m_{uS}^2) + \frac{Nm_K}{m_\pi - m_K} A_0(m_{SS}^2) \\
&+ \frac{N(m_K - 2m_\pi)}{m_\pi - m_K} A_0(m_{uS}^2) + \frac{m_K(4m_K^2 - 2m_\pi^2 - m_{SS}^2)}{N(m_K - m_\pi)(2m_K^2 - m_\pi^2)} A_0(m_{33}^2) \\
&+ \left. \frac{(2m_\pi - m_K)(2m_\pi^2 - m_{SS}^2)}{Nm_\pi^2(m_\pi - m_K)} A_0(m_\pi^2) - \frac{\Delta f_K}{f} - \frac{\Delta f_\pi}{f} \right]. \tag{E2}
\end{aligned}$$

In the case of degenerate valence quarks, the above expression becomes

$$\begin{aligned}
\langle \pi^+ | \mathcal{O}^{(8,1)} | K^+ \rangle_{\log} &= \frac{4\alpha_1}{f^2} m^2 \left\{ \frac{1}{16\pi^2 f^2} \left[\frac{4}{N} (3m^2 - m_{SS}^2) \ln \frac{m^2}{\mu^2} - \frac{3N}{2} (m^2 + m_{SS}^2) \ln \left(\frac{m^2 + m_{SS}^2}{2\mu^2} \right) + \frac{2}{N} (5m^2 - 3m_{SS}^2) \right] \right. \\
&- \frac{2\Delta f}{f} + \frac{\Delta m^2}{m^2} \left. \right\} - \frac{4\alpha_2}{f^2} m^2 \left\{ \frac{1}{16\pi^2 f^2} \left[\frac{2}{N} (4m^2 - m_{SS}^2) \ln \frac{m^2}{\mu^2} - N(m^2 + m_{SS}^2) \ln \left(\frac{m^2 + m_{SS}^2}{2\mu^2} \right) \right] \right. \\
&+ \left. \frac{1}{N} (8m^2 - 4m_{SS}^2) \right\} - \frac{2\Delta f}{f}. \tag{E3}
\end{aligned}$$

The $K \rightarrow \pi\pi$ amplitude at UK1 in infinite volume Minkowski space is given by

$$\begin{aligned}
\langle \pi^+ \pi^- | \mathcal{O}^{(8,1)} | K^0 \rangle_{\log} &= 8i \frac{\alpha_1}{f^3} m^2 \left\{ \frac{1}{16\pi^2 f^2} \left[\frac{2}{N} m_{SS}^2 \ln \frac{m^2}{\mu^2} - 3Nm^2 \ln \left(\frac{m^2 + m_{SS}^2}{2\mu^2} \right) - \frac{N}{2} (5m^2 - m_{SS}^2) \lambda_0 \right. \right. \\
&+ \lim_{s \rightarrow 4m^2} \left(\frac{\pi i (m^2 - m_{SS}^2) ((32N - 3)m^2 + 3m_{SS}^2)}{16N^2 m (s - 4m^2)^{1/2}} \right) + \frac{1}{8N} ((22N^2 - 57)m^2 + m_{SS}^2 (-2N^2 + 25)) \left. \right] \\
&- \left. \frac{3\Delta f}{f} + \frac{\Delta m^2}{m^2} \right\}, \tag{E4}
\end{aligned}$$

for $m_K = m_\pi = m$, where

$$\lambda_0 = \frac{i}{\sqrt{2}} \sqrt{\frac{m_{SS}^2}{m^2} - 1} \ln \left(\frac{\sqrt{\frac{m_{SS}^2}{m^2} - 1} - \sqrt{2}i}{\sqrt{\frac{m_{SS}^2}{m^2} - 1} + \sqrt{2}i} \right). \tag{E5}$$

Expression (E5) is real for $m_{SS}^2 \geq m^2$. When $m_{SS}^2 < m^2$, (E5) has an imaginary part. The $K \rightarrow \pi\pi$ amplitude at UK2 in infinite volume Minkowski space is

$$\begin{aligned}
 \langle \pi^+ \pi^- | \mathcal{O}^{(8,1)} | K^0 \rangle_{\log} = & 3i \frac{\alpha_1}{f^3} m_K^2 \left\{ \frac{1}{16\pi^2 f^2} \left[-\frac{m_K^2(5N^2 - 6N + 8)}{2N^2} \ln \frac{m_K^2}{\mu^2} + \frac{N}{48} \left(\frac{-16m_{SS}^4}{m_K^2} - 8m_{SS}^2 + 3m_K^2 \right) \right. \right. \\
 & \times \ln \left(\frac{7m_K^2 + 4m_{SS}^2}{\mu^2} \right) + \frac{N}{48} \left(\frac{16m_{SS}^4}{m_K^2} - 16m_{SS}^2 - 69m_K^2 \right) \ln \left(\frac{m_K^2 + 4m_{SS}^2}{\mu^2} \right) \\
 & - \frac{N}{12} (17m_K^2 + 4m_{SS}^2) \lambda_1 - \frac{N}{6} (5m_K^2 + 4m_{SS}^2) \lambda_2 + \lim_{s \rightarrow m_K^2} \left(\frac{-i\pi m_K (m_K^2 - 4m_{SS}^2)^2}{16N^2 (s - m_K^2)^{3/2}} \right. \\
 & \left. \left. + \frac{i\pi (m_K^2 - 4m_{SS}^2) (m_K^2 (24N - 43) - 20m_{SS}^2)}{96N^2 m_K (s - m_K^2)^{1/2}} \right) - \frac{(7m_K^2 - 4m_{SS}^2)^2}{3\sqrt{6}N^2 m_K^2} \cot^{-1}(\sqrt{6}) - \frac{4\sqrt{3}m_K^2}{N} \tan^{-1}\left(\frac{2}{\sqrt{3}}\right) \right. \\
 & + \frac{1}{12\sqrt{3}N^2 m_K^2} (7m_K^2 - 4m_{SS}^2) (m_K^2 (3N - 10) + 16m_{SS}^2) \tan^{-1}\left(\frac{5}{\sqrt{3}}\right) \\
 & + \frac{\pi}{72\sqrt{3}N^2 m_K^2} ((123N + 70)m_K^4 + 4m_K^2 m_{SS}^2 (3N - 38) + 64m_{SS}^4) \\
 & + \frac{\ln 7}{72N^2 m_K^2} (-(659N + 252)m_K^4 + 4m_K^2 m_{SS}^2 (107N - 6) + 96m_{SS}^4) \\
 & + \frac{\ln 2}{24N^2} ((99N^3 - 40N^2 + 432N + 192)m_K^2 + 12N m_{SS}^2 (3N^2 - 32)) \\
 & \left. \left. + \frac{1}{432N^2} ((-108N^3 + 1296N^2 + 2851N + 2160)m_K^2 - 4m_{SS}^2 (108N^3 + 43N + 432)) \right] \right. \\
 & \left. - \frac{\Delta f_K}{f} - \frac{2\Delta f_\pi}{f} + \frac{4}{3m_K^2} (\Delta m_K^2 - \Delta m_\pi^2) \right\}, \tag{E6}
 \end{aligned}$$

for $m_{K(\text{one-loop})} = 2m_{\pi(\text{one-loop})}$, where

$$\lambda_1 = i \sqrt{2 \frac{m_{SS}^2}{m_K^2} - 1} \ln \left(\frac{\sqrt{8 \frac{m_{SS}^2}{m_K^2} - 2 - 2i}}{\sqrt{8 \frac{m_{SS}^2}{m_K^2} - 2 + 2i}} \right), \tag{E7}$$

$$\lambda_2 = i \sqrt{2 \frac{m_{SS}^2}{m_K^2} - 1} \ln \left(\frac{\sqrt{8 \frac{m_{SS}^2}{m_K^2} - 2 + 4i}}{\sqrt{8 \frac{m_{SS}^2}{m_K^2} - 2 - 4i}} \right). \tag{E8}$$

Note the imaginary threshold divergences in both (E4) and (E6). On the lattice they are expected to contribute in the form of enhanced finite volume effects. See, for example, [38]. When $m_{SS} < m_K/2 = m_\pi$, Eqs. (E7) and (E8) have imaginary parts.

Equation (E6) is most useful in fits to lattice data at the special kinematics $m_{\text{sea}} = m_{u,d}$ ($m_{SS} = m_\pi$), $N = 2$. In this case it reduces to

$$\begin{aligned}
 \langle \pi^+ \pi^- | \mathcal{O}^{(8,1)} | K^0 \rangle_{\log} = & 3i \frac{\alpha_1}{f^3} m_K^4 \left\{ \frac{1}{16\pi^2 f^2} \left[-5 \ln \frac{m_K^2}{\mu^2} - \sqrt{\frac{3}{2}} \cot^{-1}(\sqrt{6}) - 2\sqrt{3} \tan^{-1}\left(\frac{2}{\sqrt{3}}\right) + \frac{\pi}{\sqrt{3}} - \frac{113}{24} \ln 7 + \frac{40}{3} \ln 2 \right. \right. \\
 & \left. \left. + \frac{25}{4} \right] - \frac{\Delta f_K}{f} - \frac{2\Delta f_\pi}{f} + \frac{4}{3m_K^2} (\Delta m_K^2 - \Delta m_\pi^2) \right\}. \tag{E9}
 \end{aligned}$$

The logarithmic contribution to UKX (kaon, pions at rest) in the special case of $m_{\text{sea}} = m_u = m_d$ ($m_{SS} = m_\pi$) and $m_K > m_\pi$ is given below. In this expression, as in all others in this set of appendices, $q^2 = (m_K - m_\pi)^2$,

$$\begin{aligned}
\langle \pi^+ \pi^- | \mathcal{O}^{(8,1)} | K^0 \rangle_{\log} = & \frac{4i\alpha_1}{f^3} m_\pi (m_K + m_\pi) \left[\frac{m_K(2m_K^2 + m_\pi^2)}{Nm_\pi 16\pi^2 f^2} - \frac{4}{N} m_K^2 (m_K^2 - m_\pi^2) C_0(0, q^2, q^2, m_{33}^2, m_{33}^2, m_K^2) \right. \\
& + \frac{1}{N} (-6m_K^2 + 4m_K m_\pi) B_0(q^2, m_K^2, m_{33}^2) + 2(N-2)m_K m_\pi B_0(q^2, m_K^2, m_\pi^2) \\
& - 4m_\pi (m_K - 2m_\pi) B_0(4m_\pi^2, m_K^2, m_\pi^2) + \frac{2}{N^2} (N-2)m_K (m_K - m_\pi) B_0(4m_\pi^2, m_\pi^2, m_{33}^2) \\
& - \frac{4}{N^2} m_\pi (2m_K - 3m_\pi) B_0(4m_\pi^2, m_{33}^2, m_{33}^2) - \frac{2}{N^2} (N^3 + 2N^2 - 2N + 2) m_\pi^2 B_0(4m_\pi^2, m_\pi^2, m_\pi^2) \\
& - \frac{N^2 m_K^3 + 4m_K^2 m_\pi + 2(N^2 + 2N - 4)m_K m_\pi^2 - 12Nm_\pi^3}{2Nm_\pi (m_K^2 - m_\pi^2)} A_0(m_K^2) \\
& - \frac{1}{2N^2 m_\pi (m_K^2 - m_\pi^2) (2m_K^2 - m_\pi^2)} (-12Nm_K^5 + 8(2N-1)m_K^4 m_\pi + 4(N+6)m_K^3 m_\pi^2 \\
& - 4(2N+3)m_K^2 m_\pi^3 + 3(N-4)m_K m_\pi^4 + 8m_\pi^5) A_0(m_{33}^2) \\
& + \frac{1}{2N^2 (m_K^2 - m_\pi^2)} (-2(N^3 - 2N + 2)m_K^2 + (3N^3 + 4N^2 - 13N + 12)m_K m_\pi \\
& + 2(N^3 - 6N^2 + 4N - 4)m_\pi^2) A_0(m_\pi^2) - \frac{\Delta f_K}{f} - \frac{2\Delta f_\pi}{f} + \frac{m_K}{2(m_K + m_\pi)} \left(\frac{\Delta m_K^2}{m_K^2} \right) \\
& + \left. \frac{m_K + 2m_\pi}{2(m_K + m_\pi)} \left(\frac{\Delta m_\pi^2}{m_\pi^2} \right) \right] + \frac{2i\alpha_2}{f^3} (m_K + m_\pi) (2m_\pi - m_K) \left[\frac{2m_K (m_K + m_\pi)}{N16\pi^2 f^2} \right. \\
& - \frac{4}{N} m_K m_\pi (m_K^2 - m_\pi^2) C_0(0, q^2, q^2, m_{33}^2, m_{33}^2, m_K^2) - \frac{6}{N} m_K m_\pi B_0(q^2, m_K^2, m_{33}^2) \\
& + 2(N-2)m_K m_\pi B_0(q^2, m_K^2, m_\pi^2) - 4m_\pi^2 B_0(4m_\pi^2, m_K^2, m_K^2) \\
& - \frac{2}{N^2} (N-2)m_K m_\pi B_0(4m_\pi^2, m_\pi^2, m_{33}^2) - \frac{4}{N^2} m_\pi^2 B_0(4m_\pi^2, m_{33}^2, m_{33}^2) \\
& - \frac{2}{N^2} (N^3 + 2N^2 - 2N + 2) m_\pi^2 B_0(4m_\pi^2, m_\pi^2, m_\pi^2) + \frac{Nm_K}{m_\pi - m_K} A_0(m_K^2) \\
& + \frac{(1-N^2)m_K^2 + (N^2-1)m_K m_\pi + 2N^2 m_\pi^2}{N(m_K^2 - m_\pi^2)} A_0(m_\pi^2) + \frac{m_K m_\pi (4m_K + 3m_\pi)}{N(m_K + m_\pi) (2m_K^2 - m_\pi^2)} A_0(m_{33}^2) \\
& - \frac{\Delta f_K}{f} - \frac{2\Delta f_\pi}{f} + \frac{m_K (-2m_K + m_\pi)}{2(m_K + m_\pi) (2m_\pi - m_K)} \left(\frac{\Delta m_K^2}{m_K^2} \right) + \frac{m_\pi (m_K + 4m_\pi)}{2(m_K + m_\pi) (2m_\pi - m_K)} \left(\frac{\Delta m_\pi^2}{m_\pi^2} \right) \\
& + \frac{32m_K m_\pi}{f^2} \left(2L_1 + 2L_2 + L_3 + \frac{m_\pi ((N-4)m_K - 2Nm_\pi)}{2m_K (m_K - 2m_\pi)} L_4 + \frac{m_K^3 - m_K^2 m_\pi - 2m_\pi^3}{2m_K m_\pi (m_K - 2m_\pi)} L_5 \right. \\
& \left. - \frac{2m_K^2 + Nm_K m_\pi - 2Nm_\pi^2}{m_K (m_K - 2m_\pi)} L_6 - \frac{m_K^3 - m_K^2 m_\pi + m_K m_\pi^2 - 2m_\pi^3}{m_K m_\pi (m_K - 2m_\pi)} L_8 \right) \left. \right]. \tag{E10}
\end{aligned}$$

APPENDIX F

The absence of the α_2 terms in $K \rightarrow \pi\pi$ at UK1 requires some corrections to [13], presented here. Equation (31) of [13] should be

$$\langle \pi^+ \pi^- | \mathcal{O}^{(8,1)} | K^0 \rangle_{\text{ct}} = 8i \frac{\alpha_1}{f^3} m^2 + 8i \frac{m^4}{f^3} [4e_{10}^r + 2e_{11}^r + 4e_{15}^r - 4e_{35}^r]. \tag{F1}$$

In Appendix D, Eq. (D6) of [13], the correct equation should read

$$\langle \pi^+ \pi^- | \mathcal{O}^{(8,1)} | K^0 \rangle_{\log} = 8i \frac{\alpha_1}{f^3} m^2 \left[-\frac{1}{6} m^2 \frac{1}{16\pi^2 f^2} \left(50 \ln \frac{m^2}{\mu^2} - 37 \right) - \frac{3\Delta f}{f} + \frac{\Delta m^2}{m^2} \right]. \tag{F2}$$

- [1] CP-PACS Collaboration, J.I. Noaki *et al.*, Phys. Rev. D **68**, 014501 (2003).
- [2] RBC Collaboration, T. Blum *et al.*, Phys. Rev. D **68**, 114506 (2003).
- [3] NA48 Collaboration, V. Fanti *et al.*, Phys. Lett. B **465**, 335 (1999); J.R. Batley *et al.*, Phys. Lett. B **544**, 97 (2002).
- [4] KTeV Collaboration, A. Alavi-Harati *et al.*, Phys. Rev. Lett. **83**, 22 (1999); A. Alavi-Harati *et al.*, Phys. Rev. D **67**, 012005 (2003).
- [5] Particle Data Group Collaboration, K. Hagiwara *et al.*, Phys. Rev. D **66**, 010001 (2002).
- [6] For an ongoing attempt at $\text{Re}(\epsilon'/\epsilon)$ using staggered fermions see T. Bhattacharya, G.T. Fleming, G. Kilcup, R. Gupta, W. Lee, and S. Sharpe, Nucl. Phys. B, Proc. Suppl. **106** 311 (2002).
- [7] For an earlier attempt using staggered fermions, see D. Pekurovsky and G. Kilcup, Phys. Rev. D **64**, 074502 (2001).
- [8] C. Bernard, T. Draper, A. Soni, H.D. Politzer, and M.B. Wise, Phys. Rev. D **32**, 2343 (1985).
- [9] L. Maiani and M. Testa, Phys. Lett. B **245**, 585 (1990).
- [10] V. Cirigliano and E. Golowich, Phys. Lett. B **475**, 351 (2000); Phys. Rev. D **65**, 054014 (2002).
- [11] J. Bijnens, E. Pallante, and J. Prades, Nucl. Phys. **B521**, 305 (1998).
- [12] C.-J.D. Lin, G. Martinelli, E. Pallante, C.T. Sachrajda, and G. Villadoro, Nucl. Phys. **B650** 301 (2003); SPQcdR Collaboration, Ph. Boucaud *et al.*, Nucl. Phys. B, Proc. Suppl. **106**, 329 (2002).
- [13] Jack Laiho and Amarjit Soni, Phys. Rev. D **65** 114020 (2002).
- [14] C. Bernard, T. Draper, G. Hockney, and A. Soni, Nucl. Phys. B, Proc. Suppl. **4**, 483 (1988).
- [15] C. Dawson *et al.*, Nucl. Phys. **B514**, 313 (1998).
- [16] C.-J.D. Lin, G. Martinelli, E. Pallante, C.T. Sachrajda, and G. Villadoro, Phys. Lett. B **581**, 207 (2004).
- [17] L. Lellouch and M. Luscher, Commun. Math. Phys. **219**, 31 (2001); see also C.-J.D. Lin, G. Martinelli, C.T. Sachrajda, and M. Testa, Nucl. Phys. B, Proc. Suppl. **109A**, 218 (2002).
- [18] Changhoan Kim and Norman H. Christ, Nucl. Phys. B, Proc. Suppl. **119**, 365 (2003).
- [19] M. Buchler, G. Colangelo, J. Kambor, and F. Orellana, Phys. Lett. B **521**, 22 (2001); G. Colangelo, Nucl. Phys. B, Proc. Suppl. **106**, 53 (2002).
- [20] S. Sharpe, Phys. Rev. D **56** 7052 (1997); S. Sharpe and N. Shores, Nucl. Phys. B, Proc. Suppl. **83**, 968 (2000); Phys. Rev. D **62**, 094503 (2000).
- [21] Maarten Golterman and Elisabetta Pallante, J. High Energy Phys. 10 (2001) 037.
- [22] Claude Bernard and Maarten Golterman, Phys. Rev. D **53**, 476 (1996).
- [23] Gilberto Colangelo and Elisabetta Pallante, Nucl. Phys. **B520** 433 (1998).
- [24] M. Ciuchini, E. Franco, G. Martinelli, L. Reina, and L. Silvestrini, Z. Phys. C **68**, 239 (1995).
- [25] G. Buchalla, A.J. Buras, and M.E. Lautenbacher, Rev. Mod. Phys. **68**, 1125 (1996).
- [26] For a succinct introduction, see H. Georgi, *Weak Interactions and Modern Particle Theory* (Benjamin/Cummings, New York, 1984).
- [27] J. Gasser and H. Leutwyler, Ann. Phys. (N.Y.) **158**, 142 (1984); Nucl. Phys. **B250**, 465 (1985).
- [28] J. Kambor, J. Missimer, and D. Wyler, Nucl. Phys. **B346**, 17 (1990).
- [29] G. Ecker, J. Kambor, and D. Wyler, Nucl. Phys. **B394**, 101 (1993).
- [30] Maarten Golterman and Elisabetta Pallante, J. High Energy Phys. 08 (2000) 023.
- [31] Claude Bernard and Maarten Golterman, Phys. Rev. D **46**, 853 (1992); C. Bernard and M. Golterman, Phys. Rev. D **49**, 486 (1994).
- [32] P.H. Damgaard and K. Splittorff, Phys. Rev. D **62** 054509 (2000).
- [33] Joachim Kambor, Ph.D. thesis, Swiss Federal Institute of Technology, 1990.
- [34] See also S.R. Sharpe, *et al.*, Nucl. Phys. **B286**, 253 (1987).
- [35] L. Maiani *et al.*, Nucl. Phys. **B289**, 505 (1987); S. Capitani and L. Giusti, Phys. Rev. D **64**, 014506 (2001).
- [36] M. Golterman and E. Pallante, Phys. Rev. D **69**, 074503 (2004).
- [37] M. Golterman and S. Peris, Nucl. Phys. B, Proc. Suppl. **129**, 311 (2004).
- [38] C.-J.D. Lin, G. Martinelli, E. Pallante, C.T. Sachrajda, and G. Villadoro, Phys. Lett. B **553** 229 (2003).
- [39] M. Golterman, C.-J.D. Lin, and E. Pallante, Phys. Rev. D **69**, 057503 (2004).
- [40] E. Pallante, A. Pich, and I. Scimemi, Nucl. Phys. **B617** 441 (2001).
- [41] RBC Collaboration, Taku Izubuchi, Nucl. Phys. B, Proc. Suppl. **119**, 813 (2003).
- [42] R. Mertig, M. Bohm, and A. Denner, Comput. Phys. Commun. **64**, 345 (1991).
- [43] S. Wolfram, *Mathematica—A System for Doing Mathematics by Computer* (Addison-Wesley, New York, 1988).
- [44] G. Passarino and M. Veltman, Nucl. Phys. **B160**, 151 (1979).