

Vector meson pair production in two-photon collisions near threshold

Jonathan L. Rosner*

Laboratory of Elementary Particle Physics, Cornell University, Ithaca, New York 14850, USA

(Received 5 May 2004; published 26 August 2004)

The cross sections for several $\gamma\gamma \rightarrow VV$ processes exhibit strong enhancements near threshold, where V denotes a vector meson. The pattern of these enhancements is not well understood; for example, $\gamma\gamma \rightarrow \rho^0 \rho^0$ shows an appreciable peak, while $\gamma\gamma \rightarrow \rho^+ \rho^-$ does not. Some possible mechanisms for this behavior are discussed. Tests are proposed involving production of systems containing heavier quarks, e.g., through the reaction $\gamma\gamma \rightarrow J/\psi \rho^0$. The importance of modeling $\ell^+ \ell^- \pi^+ \pi^-$ angular distributions in decays of threshold $J/\psi \rho^0$ enhancements is illustrated by comparing the expected distributions for S-wave decays of scalar particles and P-wave decays of pseudoscalar particles.

DOI: 10.1103/PhysRevD.70.034028

PACS number(s): 12.39.Mk, 13.60.Le, 13.66.Bc, 14.40.Cs

I. INTRODUCTION

The properties of meson and baryon resonances can be strongly influenced not only by their intrinsic quark content, but also by the final states to which they couple. Recently several resonances have been reported for which these effects may be important. These include $J^P=0^+$ and 1^+ charmed-strange mesons several tens of MeV below the DK and D^*K threshold, respectively [1–3] and a charmonium resonance $X(3872)$ nearly degenerate with the $D^0 \bar{D}^{*0}$ threshold [4,5]. Such effects may also be important for the reactions $\gamma\gamma \rightarrow VV$, where V is a vector meson. In the present paper I discuss some proposals to account for the curious pattern of threshold enhancements in these processes, note the availability of the $J/\psi \rho$ channel, and calculate angular distributions for two cases of spinless particle decay to $J/\psi \rho$.

The cross section for $\gamma\gamma \rightarrow \rho^0 \rho^0$ is strongly enhanced near threshold [6,7], while $\gamma\gamma \rightarrow \rho^+ \rho^-$ is not [8]. This difference appears to occur mainly for real or nearly real photons; when one photon is highly virtual the cross sections for $\gamma\gamma^* \rightarrow \rho^0 \rho^0$ [9] and $\gamma\gamma^* \rightarrow \rho^+ \rho^-$ [10] are much more similar. It will be interesting to see whether a recent calculation of $\gamma\gamma^* \rightarrow \rho^0 \rho^0$ [11] can reproduce the result for $\gamma\gamma^* \rightarrow \rho^+ \rho^-$.

Other $\gamma\gamma \rightarrow VV$ processes exhibit patterns [12] not all of which can be understood from a single standpoint. A review of $\gamma\gamma$ interactions up to 2001 may be found in Ref. [13]. Additional relevant experimental data come from a recent search for the $X(3872)$ in photon-photon collisions, in which a sample of $J/\psi \pi^+ \pi^-$ events has been studied [14], and which is the main motivation for the present study.

Photon-photon collisions share features with hadron-hadron collisions, but have properties making them easier to interpret. In hadronic processes at low transverse momentum one can regard photons as superpositions of vector mesons $\rho + \omega + \phi$ with relative couplings $3:1:\sqrt{2}$ [15]. SU(3) symmetry is broken through a lower total cross section of ϕ

mesons with non-strange hadrons. A similar approach describes J/ψ photoproduction through a suppressed J/ψ -nucleon cross section [16].

This paper is organized as follows. Section II reviews the processes $\gamma\gamma \rightarrow VV$. I discuss some possible mechanisms for the threshold enhancement of such processes in Sec. III. Section IV is devoted to information available from the process $\gamma\gamma \rightarrow J/\psi \rho^0$, while Sec. V concludes.

II. DATA ON $\gamma\gamma \rightarrow VV$

The cross sections for $\gamma\gamma \rightarrow VV$ generally peak not far above threshold. The greatest enhancement occurs for $\rho^0 \rho^0$, for which $\sigma(\gamma\gamma \rightarrow \rho^0 \rho^0)$ rises to a maximum of $\sim(57 \pm 6)$ nb in the photon-photon center-of-mass energy range $W = 1.5$ to 1.6 GeV [7] and in the state with $(J=2, J_z = \pm 2)$. No such enhancement is seen in $\gamma\gamma \rightarrow \rho^+ \rho^-$. The cross section for the corresponding partial wave shows a dip in this region and never exceeds $\sim(12 \pm 4)$ nb [8]. The peak cross sections σ_{pk} and the energy ranges W in which they occur [17] are summarized in Table I [7,8,18–21].

An interesting feature of several of the threshold bumps is that in cases in which a partial-wave analysis is possible (such as $\gamma\gamma \rightarrow \rho^0 \rho^0$ and $\gamma\gamma \rightarrow K^{*0} \bar{K}^{*0}$) they occur in the $(J=2, J_z = \pm 2)$ state, with little activity in $J=0$ or $J=2, J_z=0$.

TABLE I. Energy ranges and peak cross sections for $\gamma\gamma \rightarrow VV$.

VV	W (GeV)	σ_{pk} (nb)	Reference
$\rho^0 \rho^0$	1.5–1.6	57 ± 6 ^a	[7]
$\rho^+ \rho^-$	~ 1.3	12 ± 4 ^a	[8]
$\rho^0 \omega$	1.5–1.7	17.3 ± 3.5	[18]
$\omega \omega$	1.6–1.8	4.3 ± 1.5	[19]
$\rho^0 \phi$	1.75–2.00	2.2 ± 1.1	[20]
$\omega \phi$	1.9–2.3	1.65 ± 0.86	[20]
$K^{*+} K^{*-}$	2.00–2.25	36.20 ± 6.25	[21]
$K^{*0} \bar{K}^{*0}$	1.75–2.00	5.97 ± 0.78	[21]

^aIn partial wave $J=2, J_z = \pm 2$.

*On leave from Enrico Fermi Institute and Department of Physics, University of Chicago, 5640 S. Ellis Avenue, Chicago, IL 60637. Electronic address: rosner@hep.uchicago.edu

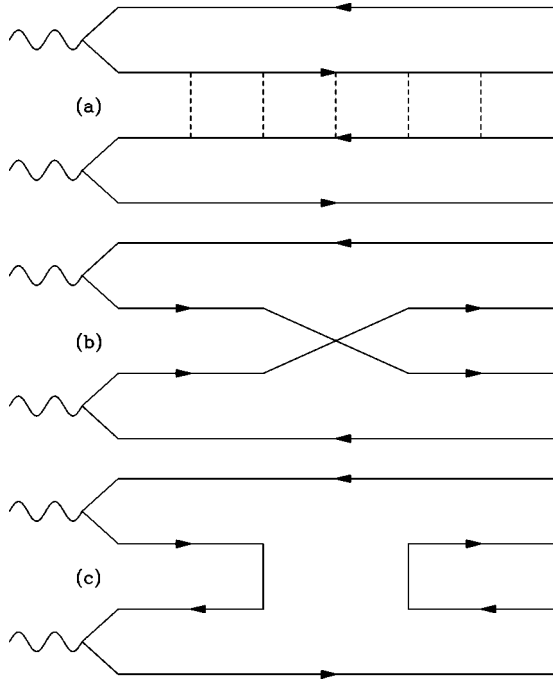

FIG. 1. Quark diagrams illustrating possible mechanisms for threshold enhancement of vector meson pair production by two photons. (a) Exchange of $I=0$ mesons (dashed lines); (b) quark exchange; (c) quark-antiquark annihilation and pair creation.

III. MECHANISMS FOR THRESHOLD ENHANCEMENTS

The preponderance of $\rho^0\rho^0$ over $\rho^+\rho^-$ near threshold could be due [22,23] to a superposition of resonances with isospins zero and two near $\rho\rho$ threshold, coupling much more strongly to $\rho^0\rho^0$ than to $\rho^+\rho^-$. If there really is a $\rho\rho$ resonance near threshold with $I=2$, there should exist states around 1600 MeV decaying to $\rho^\pm\rho^\pm$. While no such states have been seen so far, the relevant final state $\pi^\pm\pi^\pm\pi^0\pi^0$ has not been carefully examined in a detector with good sensitivity to both charged and neutral particles. Such detectors as CLEO, BaBar, and Belle, constructed to investigate e^+e^- collisions at energies suitable for studying the decays of B mesons, would be excellent places to pursue such searches [24].

It should be possible to construct a set of resonances sufficient to reproduce the pattern of Table I. Some difficulty in this regard was pointed out in Ref. [25]. A resonance which decays to $K^{*+}K^{*-}$ should, in principle, also be able to decay to $\rho^0\phi$ unless it has isospin zero. But then it should have the same branching ratio to $K^{*0}\bar{K}^{*0}$ as to $K^{*+}K^{*-}$, which is certainly not suggested by the pattern of peak cross sections.

Another view of the $\rho^0\rho^0$ enhancement [26] is that each photon produces a ρ^0 and these vector mesons then interact with one another through the repeated exchange of an $I=0$ meson “ σ ,” leading to an effective potential between the vector mesons. This mechanism is illustrated in Fig. 1(a). It does not contribute to $\gamma\gamma\rightarrow\rho^+\rho^-$, accounting for the suppression of that process. But it also does not contribute to

$\gamma\gamma\rightarrow K^*\bar{K}^*$, a shortcoming which is particularly acute for the charged pair.

The presence of the threshold enhancement in $\gamma\gamma\rightarrow\rho^0\rho^0$ in the state of total angular momentum $J=2$ and helicity $J_z=\pm 2$ [7] can be reproduced in resonance models [22,23] by suitable choices of coupling constants. It need not be universal. In the model of Ref. [26] the dominance of $(J,J_z)=(2,\pm 2)$ can be reproduced by spin dependence in the potential between the vector mesons. If this potential is flavor-independent one would expect all possible $\gamma\gamma\rightarrow V_1V_2$ cross sections involving the diffractive process of Fig. 1(a) to exhibit the same behavior as $\gamma\gamma\rightarrow\rho^0\rho^0$: a rapid rise near threshold in the $(J,J_z)=(2,\pm 2)$ amplitude and little activity in other partial waves.

Flavor-dependent effects which could enhance the $(J,J_z)=(2,\pm 2)$ amplitude include exchange of two identical quarks or quark-antiquark annihilation between the two vector mesons, as illustrated in Figs. 1(b) and 1(c). I assume that the initial vector mesons are produced only with $J_z=\pm 1$, i.e., with the same polarizations as the incident photons. Similar diagrams were considered in a perturbative QCD calculation of nondiffractive $\gamma\gamma\rightarrow VV$ processes [27].

In the case of quark exchange, the quarks trading places in the vector mesons have identical J_z values only for the $J_z=\pm 2$ amplitudes, while for the $J_z=0$ amplitudes they necessarily have opposite J_z values. If the flavors of the two exchanged quarks do not matter, one can have enhancements in processes $\gamma\gamma\rightarrow V_1V_2$ where V_1 and V_2 are not able to couple directly to photons. The initial process $\gamma\gamma\rightarrow\rho^0\rho^0$ could then lead to a $\rho^+\rho^-$ final state, while $\gamma\gamma\rightarrow\rho^0\phi$ could lead to $K^{*+}K^{*-}$. The absence of such an enhancement in $\gamma\gamma\rightarrow\rho^+\rho^-$ appears to disfavor this mechanism. One must then stipulate that the exchanged quarks be identical, requiring additional dynamical assumptions.

In the case of quark-antiquark annihilation, as long as the annihilation must take place in a state of $J_z=\pm 1$ (as, for example, in $q\bar{q}\rightarrow g$, where g is a transversely polarized gluon), the initial vector mesons must have the same J_z value. The remaining $q'\bar{q}'$ pair will be left with $J_z=\pm 1$. If the transversely polarized gluon then materializes into a different quark-antiquark pair, one will be left with a pair of transversely polarized vector mesons different in flavor from the previous one, so one should expect a threshold enhancement in $\gamma\gamma\rightarrow\rho^+\rho^-$, $\gamma\gamma\rightarrow K^{*+}K^{*-}$, and so on. As in the previous case, the absence of a threshold enhancement in $\gamma\gamma\rightarrow\rho^+\rho^-$ disfavors this alternative.

The relative strengths of the threshold enhancements in $\gamma\gamma\rightarrow K^{*+}K^{*-}$ and $\gamma\gamma\rightarrow K^{*0}\bar{K}^{*0}$ do argue for some contribution related to quark exchange and/or annihilation. In either case charged K^* production is favored because one or both photons couples to a u quark with charge $2/3$, while neutral K^* production involves replacing this quark with a d quark with charge $-1/3$ [27]. But an attempt to use the diagrams of Fig. 1 for a unified description within flavor SU(3) founders immediately on the inequality of the $\rho^+\rho^-$ and $K^{*+}K^{*-}$ cross sections, predicted to be equal within the U-spin subgroup of SU(3) involving the interchange of d and s quarks.

A further mechanism which could account for a threshold enhancement in $\gamma\gamma\rightarrow\rho^0\rho^0$ with $J_z=\pm 2$ is the effect of Bose statistics in the final state [28]. A transversely polarized photon with helicity $\lambda=\pm 1$ will produce a $\pi^+\pi^-$ pair with angular wave function proportional to $Y_\lambda^1(\theta,\phi)$, where (θ,ϕ) are the polar angles of the π^+ with respect to the beam axis in the dipion rest frame. At $\rho^0\rho^0$ threshold the two dipion rest frames coincide, leading to the possibility of coherent reinforcement of processes in which both dipion systems have the same wave functions $Y_\lambda^1(\theta_i,\phi_i)(i=1,2)$. As the center-of-mass energy increases above threshold, the dipion wave functions refer to individual rest frames which become distinct from one another, reducing the possibility of coherence.

The effects of Bose statistics (the Goldhaber-Goldhaber-Lee-Pais effect, or ‘‘GGLP effect’’ [28]) have been observed in $\gamma\gamma\rightarrow 3\pi^+3\pi^-$ as an enhancement in the low- $m(\pi^\pm\pi^\pm)$ distribution [29]. However, it appears that these effects have been ignored up to now in the simpler process $\gamma\gamma\rightarrow 2\pi^+2\pi^-$.

The above realization of the GGLP mechanism implies threshold effects in other cases of $\gamma\gamma\rightarrow V_1V_2$ besides $V_1=V_2=\rho^0$, but details may differ. If the decay products of V_1 and V_2 are not all identical, their overlaps will be reduced. Such is the case, for example in $\gamma\gamma\rightarrow\rho^+\rho^-\rightarrow\pi^+\pi^0\pi^-\pi^0$, where only the two neutral pions can overlap. It is not even clear that under such circumstances their relative phases would be the same as those of the identical pions in $\gamma\gamma\rightarrow\rho^0\rho^0\rightarrow\pi^+\pi^-\pi^+\pi^-$.

If the decay product of the two vector mesons are identical, one is left with the additional processes $\gamma\gamma\rightarrow\omega\omega, \phi\phi, J/\psi J/\psi, \dots$, where both vector mesons decay to the same final state. Thus, in $\gamma\gamma\rightarrow\phi\phi$, a threshold enhancement should be present when both ϕ mesons decay to K^+K^- , but not when one decays to K^+K^- and the other to $K_S K_L$.

The width of the decaying vector meson also probably plays a crucial role. The probability of overlap of the decay products of two ρ^0 mesons is very high since the ρ^0 has an appreciable width of about 150 MeV [30]. Each ρ^0 thus can decay to $\pi^+\pi^-$ in the vicinity of the other ρ^0 before they move apart from one another. The width of the threshold enhancement (about 300 MeV) could then reflect the range of center-of-mass energies over which this mechanism can occur.

The overlap of the decay products of two ω mesons is reduced for two reasons. First, the ω is much narrower, with a width of about 8 MeV [30]; second, the predominantly three-body decay of each ω implies a much lower probability for overlap of the two vector mesons’ decay products.

The process $\gamma\gamma\rightarrow\omega\omega$, having isospin $I=0$, cannot benefit from $I=0-I=2$ interference [22,23] to account for the $\rho^0\rho^0$ threshold enhancement. It nonetheless exhibits a broad threshold enhancement [19], rising to a maximum of about 4 nb near a center-of-mass energy of 2 GeV. This is to be compared with the peak value of nearly 60 nb mentioned earlier for $\gamma\gamma\rightarrow\rho^0\rho^0$. The reduced coupling of the photon to the ω (1/3 of that to the ρ) more than explains this suppres-

sion; in a naive vector-dominance model one would have expected $60/3^4\approx 0.75$ nb. Thus some mechanism in addition to the GGLP effect seems to be in operation.

For $\gamma\gamma\rightarrow\phi\phi$ the ~ 4 MeV width of the ϕ [30] implies that the decay products of each ϕ will be well separated from one another except just above threshold, so the GGLP effect would imply a *very narrow threshold enhancement*, no more than a few MeV wide, in $\gamma\gamma\rightarrow\phi\phi\rightarrow 2K^+2K^-$. This enhancement should occur, as it does for $\gamma\gamma\rightarrow\rho^0\rho^0$, in states with total two-photon helicity $J_z=\pm 2$. Up to now there has been no reported observation of $\gamma\gamma\rightarrow\phi\phi$.

The GGLP effect discussed above has very different implications from some other mechanisms for the threshold behavior of $\gamma\gamma\rightarrow V_1V_2$, where V_1 and V_2 are neutral mesons but $V_1\neq V_2$. For example, the GGLP mechanism predicts no threshold enhancement in $\gamma\gamma\rightarrow\pi^+\pi^-K^+K^-$ near the $\rho^0\phi$ threshold, whereas a flavor-independent threshold attraction between vector mesons would imply such an enhancement.

In fact, threshold enhancements are seen in *several* $\gamma\gamma\rightarrow V_1V_2$ ($V_1\neq V_2$) processes [18]. The cross section for $\gamma\gamma\rightarrow\rho^0\omega$ peaks at $17.3\pm 3.1\pm 1.7$ nb in the center-of-mass energy range $1.5<W<1.7$ GeV. The cross section for $\gamma\gamma\rightarrow\rho^0\phi$ peaks at $2.2\pm 1.1\pm 0.3$ nb in the range $1.75<W<2$ GeV. A cross section $\sigma(\gamma\gamma\rightarrow\omega\phi)=1.65\pm 0.86$ nb is measured between 1.9 and 2.3 GeV. All these cross sections fall off appreciably as W increases. The absence of interference between V_1 and V_2 decay products makes it impossible to distinguish between $J_z=0$ and $J_z=\pm 2$ production.

An approach which combines several aspects of the above proposals, known as the ‘‘threshold t -channel factorization model,’’ is able to account for some features of the data summarized in Table I [31]. It is applied primarily to diffractive processes for which the diagram of Fig. 1(a) can contribute, with low-energy contributions from other exchanges as well. The combination of these effects can lead to a peak near threshold. The model has less to say about nondiffractive processes in which only the flavor topologies of Figs. 1(b) and 1(c) are relevant.

To summarize this section, there are appealing features of several of the proposed models for threshold enhancements of $\gamma\gamma\rightarrow VV$, but no obvious regularities in behavior that would permit one model to be selected over others. *Ad hoc* resonances, including exotic ones [22,23], appear to require considerable fine-tuning if they are to explain the observed pattern. They nonetheless have the considerable advantage of firmly predicting an $I=2$ resonance around 1600 MeV which should decay to $\rho^\pm\rho^\pm$. There are clearly some aspects of double-diffractive production in the hierarchy $\sigma_{\text{pk}}(\rho^0\rho^0) > \sigma_{\text{pk}}(\rho^0\omega) > \sigma_{\text{pk}}(\omega\omega)$, reflecting the hierarchy of photon-vector meson couplings, but SU(3) breaking is needed to account for $\rho^0\phi$ and $\omega\phi$ suppression, and evidence for the expected hierarchy $\sigma_{\text{pk}}(\rho^0\phi) > \sigma_{\text{pk}}(\omega\phi)$ is fairly weak. Altogether the situation calls for some new insight and/or data. The availability of photon-photon collisions in larger samples amassed by the CLEO, BaBar, and Belle Collaborations permits one not only to augment the statistics of the processes just mentioned, but to investigate new ones, such as the process $\gamma\gamma\rightarrow J/\psi\pi^+\pi^-$ to which I now turn.

IV. INFORMATION FROM $\gamma\gamma \rightarrow J/\psi\pi^+\pi^-$

The recently studied process $\gamma\gamma \rightarrow J/\psi\pi^+\pi^-$ [14] can provide further information on threshold enhancements in vector meson pair production by two photons. If a flavor-independent interaction between vector mesons is responsible for enhanced production near threshold, this process should exhibit such an effect. The reaction $e^+e^- \rightarrow J/\psi\pi^+\pi^- + X$ employed to study this process also contains events in which one lepton loses a large amount of energy, $e^+e^- \rightarrow \gamma\psi' \rightarrow \gamma J/\psi\pi^+\pi^-$, but backgrounds from these ‘‘radiative return’’ events can be isolated by means of angular correlations of lepton pairs in the J/ψ decays.

If $\gamma\gamma \rightarrow J/\psi\pi^+\pi^-$ is proceeding through a threshold enhancement of $J/\psi\rho^0$ production related to the above effects, several key features should be present in the data. The vector mesons should both be transversely polarized. The leptons in $J/\psi \rightarrow \ell^+\ell^-$ should then be distributed with probability $W_{\ell^+\ell^-} \sim 1 + \cos^2\theta$ with respect to the beam axis, while the pions in $\rho^0 \rightarrow \pi^+\pi^-$ should have a distribution $W_{\pi^+\pi^-} \sim \sin^2\theta$. Pions arising from the radiative-return background $\psi' \rightarrow \pi^+\pi^- J/\psi$ should be emitted isotropically in their center-of-mass system. Unfortunately it will be impossible to distinguish production with two-photon helicity $J_z = \pm 2$ from $J_z = 0$ since the J/ψ and ρ^0 decay products do not interfere with one another.

If a flavor-independent threshold enhancement mechanism is operative, the cross section for $\gamma\gamma \rightarrow J/\psi\rho$ can be related to that for (e.g.) $\gamma\gamma \rightarrow \phi\rho \sim 2$ nb by the scaling rule [16]

$$\frac{\sigma(\gamma\gamma \rightarrow J/\psi\rho)}{\sigma(\gamma\gamma \rightarrow \phi\rho)} = \left(\frac{g_{J/\psi}}{g_\phi}\right)^2 \left(\frac{M_\phi}{M_{J/\psi}}\right)^4 \left(\frac{\sigma(J/\psi\rho)}{\sigma(\phi\rho)}\right)^2, \quad (1)$$

where g_V is the coupling of vector meson V to the photon, while $\sigma(V_1V_2)$ is the total cross section for scattering of vector mesons V_1 and V_2 on each other. Neglecting differences in masses and wave functions, the couplings g_V would scale as quark charges, entailing $g_{J/\psi}/g_\phi = -2$. In fact the ratio of leptonic widths [30] implies

$$\begin{aligned} \left(\frac{g_{J/\psi}}{g_\phi}\right)^2 \left(\frac{M_\phi}{M_{J/\psi}}\right)^3 &= \frac{\Gamma_{ee}(J/\psi)}{\Gamma_{ee}(\phi)} = \frac{(5.26 \pm 0.37) \text{ keV}}{(1.26 \pm 0.02) \text{ keV}} \\ &= 4.18 \pm 0.30. \end{aligned} \quad (2)$$

The scaling arguments of Ref. [16] imply that

$$\frac{\sigma(J/\psi\rho)}{\sigma(\phi\rho)} = \frac{M_\phi^2}{M_{J/\psi}^2} \quad (3)$$

so that one predicts

$$\begin{aligned} \sigma(\gamma\gamma \rightarrow J/\psi\rho^0) &= \sigma(\gamma\gamma \rightarrow \phi\rho^0) \frac{M_\phi^5}{M_{J/\psi}^5} \frac{\Gamma_{ee}(J/\psi)}{\Gamma_{ee}(\phi)} \\ &\simeq (26 \pm 13) \text{ pb}. \end{aligned} \quad (4)$$

This estimate for the cross section near threshold is to be compared with a range of 14–20 pb at $W = 10$ GeV obtained in Ref. [32], growing significantly at higher energies in a model-dependent manner.

The result (4) can be translated into a cross section for $e^+e^- \rightarrow e^+e^- J/\psi\rho^0$ via two nearly real photons through the relation [33]

$$\begin{aligned} \sigma(e^+e^- \rightarrow e^+e^- X) \\ \simeq \left(\frac{2\alpha}{\pi} \ln \frac{E}{m_e}\right)^2 \int_{W_{th}}^{2E} \frac{dW}{W} f\left(\frac{W}{2E}\right) \sigma_{\gamma\gamma \rightarrow X}(W), \end{aligned} \quad (5)$$

where $f(x) \equiv (2+x^2)^2 \ln(1/x) - (1-x^2)(3+x^2)$, W is the photon-photon center-of-mass energy, and E is the electron or positron beam energy (in a symmetric collider configuration). The cross section $\sigma_{\gamma\gamma \rightarrow X}(W)$ may be approximated by a Breit-Wigner form

$$\sigma_{\gamma\gamma \rightarrow X}(W) \simeq \frac{\sigma_{\gamma\gamma}^{\text{pk}}}{[2(W - W_0)/\Gamma]^2 + 1}, \quad (6)$$

where W_0 and Γ are the mass and width of the resonance. In the narrow-resonance approximation (crude, but sufficient for our purposes) one then has

$$\sigma(e^+e^- \rightarrow e^+e^- X) \simeq \frac{2\Gamma}{\pi W_0} \left(\alpha \ln \frac{E}{m_e}\right)^2 f\left(\frac{W_0}{2E}\right) \sigma_{\gamma\gamma}^{\text{pk}}. \quad (7)$$

For $E = 5$ GeV, $\Gamma = 200$ MeV, $W_0 = 3.7$ GeV, one has $f(W_0/[2E]) = 1.83$, and Eq. (7) gives $\sigma(e^+e^- \rightarrow e^+e^- X)/\sigma_{\gamma\gamma}^{\text{pk}} \simeq 2.8 \times 10^{-4}$. (Use of a slightly more accurate expression [14] reduces this estimate by about 10%.) Thus, for a peak cross section given by Eq. (4), one estimates $\sigma(e^+e^- \rightarrow e^+e^- J/\psi\rho^0) \sim 7$ fb, with a 50% error. Since the data sample reported in Ref. [14] consists of 15 fb^{-1} , one should see a handful of events in which the J/ψ decays to $\mu^+\mu^-$ or e^+e^- in that sample, and considerably more in samples accumulated by the BaBar and Belle Collaborations.

In calculating the sensitivity of a detector to $J/\psi\rho^0$ decays of a resonance with definite spin J and parity P one needs the angular distributions of final $\ell^+\ell^-\pi^+\pi^-$ systems associated with each J^P value. Angular distributions have been treated in previous work (see, e.g., Ref. [7]), but for $\ell^+\ell^-\pi^+\pi^-$ final states great simplifications are possible using a *transversity basis* [34,35]. To illustrate the nontrivial nature of these distributions it is helpful to compare them for the decays of $J^P = 0^+$ and 0^- particles into the lowest available partial waves, respectively, S and P waves. One defines coordinate systems and three angles ψ, θ, φ in the following manner [35].

In the rest frame of the $\pi^+\pi^-$ system, the x axis is defined as the negative of the unit vector pointing in the direction of travel of the J/ψ . The $\pi^+\pi^-$ system is assumed to lie in the x - y plane, with π^+ making an angle ψ with the x axis ($0 \leq \psi \leq \pi$).

The z axis is taken in the J/ψ rest frame perpendicular to the plane containing the $\pi^+\pi^-$ pair, using a right-handed coordinate system. In this frame the unit vector $\hat{n}(\ell^+)$ along

the direction of the positive lepton has coordinates $(n_x, n_y, n_z) = (\sin \theta \cos \varphi, \sin \theta \sin \varphi, \cos \theta)$, thereby defining θ and ϕ .

Applying the methods of Ref. [35], one then finds

$$\frac{1}{\bar{\Gamma}} \frac{d^3\Gamma}{d \cos \theta d\varphi d \cos \psi} = \frac{9}{32\pi} \times \begin{cases} 1 - \sin^2 \theta \cos^2(\psi - \varphi) & (0^+) \\ \sin^2 \theta \sin^2 \psi & (0^-) \end{cases} \quad (8)$$

for the differential angular distributions. A clear difference is present. The sensitivity of any detector to this difference will depend upon its angular coverage and whether symmetric or asymmetric e^+e^- collisions are employed. With sufficient statistics, a distinction between even and odd parity becomes possible. Similar methods can be applied to the decays of 2^{\pm} threshold enhancements.

V. CONCLUSIONS

The two-photon processes $\gamma\gamma \rightarrow V_1 V_2$, where V_1 and V_2 are vector mesons, display threshold enhancements in a variety of cases, notably for $V_1 = V_2 = \rho^0$ but also elsewhere. I

have reviewed several proposals for these enhancements and proposed others, such as effects due to Bose statistics in decays of the vector mesons. Tests involving production of ρ , ω , and ϕ mesons, performed over many years, now can be augmented by the study of such processes as $\gamma\gamma \rightarrow J/\psi \rho^0$, for which a simple model based on flavor universality of the threshold enhancement predicts a cross section of 26 ± 13 pb. Angular distributions of decay products are illustrated for spinless threshold enhancements and shown to be sensitive to parity.

ACKNOWLEDGMENT

I thank Roy Briere, Shmuel Nussinov, Kam Seth, David Uner, Helmut Vogel, Jim Wiss, and Pete Zweber for discussions, Maury Tigner for extending the hospitality of the Laboratory for Elementary-Particle Physics at Cornell during this research, and Bernard Pire and Magno Machado for calling my attention to Refs. [11] and [32]. This work was supported in part by the United States Department of Energy through Grant No. DE FG02 90ER40560 and in part by the John Simon Guggenheim Memorial Foundation.

-
- [1] BABAR Collaboration, B. Aubert *et al.*, Phys. Rev. Lett. **90**, 242001 (2003).
- [2] CLEO Collaboration, D. Besson *et al.*, Phys. Rev. D **68**, 032002 (2003).
- [3] Belle Collaboration, K. Abe *et al.*, Phys. Rev. Lett. **92**, 012002 (2004).
- [4] Belle Collaboration, S.K. Choi *et al.*, Phys. Rev. Lett. **91**, 262001 (2003).
- [5] CDF II Collaboration, D. Acosta *et al.*, arXiv:hep-ex/0312021.
- [6] TASSO Collaboration, R. Brandelik *et al.*, Phys. Lett. B **97**, 448 (1980); TASSO Collaboration, M. Althoff *et al.*, Z. Phys. C **16**, 13 (1982); Mark II Collaboration, D.L. Burke *et al.*, Phys. Lett. B **103**, 153 (1981); CELLO Collaboration, H.J. Behrend *et al.*, Z. Phys. C **21**, 205 (1984); TPC/2 γ Collaboration, H. Aihara *et al.*, Phys. Rev. D **37**, 28 (1988); PLUTO Collaboration, Ch. Berger *et al.*, Z. Phys. C **38**, 521 (1988).
- [7] ARGUS Collaboration, H. Albrecht *et al.*, Z. Phys. C **50**, 1 (1991), and references therein.
- [8] ARGUS Collaboration, H. Albrecht *et al.*, Phys. Lett. B **267**, 535 (1991), and references therein.
- [9] L3 Collaboration, P. Achard *et al.*, Phys. Lett. B **568**, 11 (2003), and references therein.
- [10] L3 Collaboration, P. Achard *et al.*, CERN Report No. CERN-PH-EP/2004-005, 2004 (unpublished).
- [11] I.V. Anikin, B. Pire, and O.V. Teryaev, Phys. Rev. D **69**, 014018 (2004).
- [12] ARGUS Collaboration, H. Albrecht *et al.*, Phys. Rep. **276**, 223 (1996).
- [13] M.R. Whalley, J. Phys. G **27**, A1 (2001).
- [14] P. Zweber, presented on behalf of the CLEO Collaboration at the Spring Meeting of the American Physical Society, Denver, 2004.
- [15] For a review see D. W. G. Leith, SLAC-PUB-1041, Lectures presented to Scottish Univ. Summer School in Physics, 1970.
- [16] C.E. Carlson and P.G.O. Freund, Phys. Rev. D **11**, 2453 (1975).
- [17] I shall quote exclusively results based on the ARGUS data sample, consisting of 455 pb $^{-1}$ taken at beam energies between 4.7 and 5.3 GeV [12]. Although other detectors (e.g., CLEO, BaBar, and Belle) have registered much larger data samples, their results on two-photon vector meson production have not yet appeared in print.
- [18] E. Križnič, Ph. D. Thesis, University of Ljubljana, 1994, Report No. IJS-DP-6928 (unpublished).
- [19] ARGUS Collaboration, H. Albrecht *et al.*, Phys. Lett. B **374**, 265 (1996).
- [20] ARGUS Collaboration, H. Albrecht *et al.*, Phys. Lett. B **332**, 451 (1994).
- [21] ARGUS Collaboration, H. Albrecht *et al.*, Eur. Phys. J. C **16**, 435 (2000).
- [22] N.N. Achasov, S.A. Devyanin, and G.N. Shestakov, Phys. Lett. B **108**, 134 (1982); **108**, 435(E) (1982); Z. Phys. C **16**, 55 (1982); **27**, 99 (1985); N.N. Achasov and G.N. Shestakov, Usp. Fiz. Nauk **161**, 53 (1991) [Sov. Phys. Usp. **34**, 471 (1991)].
- [23] B.A. Li and K.F. Liu, Phys. Lett. B **118**, 435 (1982); **124**, 550(E) (1983); Phys. Rev. Lett. **51**, 1510 (1983); Phys. Rev. D **30**, 613 (1984); Phys. Rev. Lett. **58**, 2288 (1987); Phys. Rev. D **40**, 2856 (1989).
- [24] J.L. Rosner, Phys. Rev. D **69**, 094014 (2004).
- [25] N.N. Achasov, V.A. Karnakov, and G.N. Shestakov, Int. J. Mod. Phys. A **5**, 2705 (1990).
- [26] B. Bajc, S. Prelovsek, and M. Rosina, Z. Phys. A **356**, 187 (1996).
- [27] S.J. Brodsky, G. Kopp, and P.M. Zerwas, Phys. Rev. Lett. **58**, 443 (1987).
- [28] G. Goldhaber, S. Goldhaber, W.Y. Lee, and A. Pais, Phys. Rev. **120**, 300 (1960).

- [29] JADE Collaboration, R. Pust *et al.*, *Z. Phys. C* **51**, 531 (1991).
- [30] Particle Data Group, K. Hagiwara *et al.*, *Phys. Rev. D* **66**, 010001 (2002).
- [31] G. Alexander, U. Maor, and P.G. Williams, *Phys. Rev. D* **26**, 1198 (1982); G. Alexander, A. Levy, and U. Maor, *Z. Phys. C* **30**, 65 (1986); G. Alexander, A. Levy, S. Nussinov, and J. Grunhaus, *Phys. Rev. D* **37**, 1328 (1988); G. Alexander, A. Levy, and U. Maor, *ibid.* **46**, 2882 (1992).
- [32] V.P. Gonçalves and M.V.T. Machado, *Eur. Phys. J. C* **29**, 271 (2003).
- [33] S.J. Brodsky, T. Kinoshita, and H. Terazawa, *Phys. Rev. Lett.* **25**, 972 (1970); *Phys. Rev. D* **4**, 1532 (1971).
- [34] I. Dunietz, H.R. Quinn, A. Snyder, W. Toki, and H.J. Lipkin, *Phys. Rev. D* **43**, 2193 (1991).
- [35] A.S. Dighe, I. Dunietz, H.J. Lipkin, and J.L. Rosner, *Phys. Lett. B* **369**, 144 (1996).