

Case study in dimensional deconstruction

Kenneth Lane*

Fermi National Accelerator Laboratory, P.O. Box 500, Batavia, Illinois 60510

and Department of Physics, Boston University, 590 Commonwealth Avenue, Boston, Massachusetts 02215†

(Received 15 February 2002; published 23 May 2002)

We test dimensional deconstruction on a model of Arkani-Hamed, Cohen, and Georgi that is predicted to have a naturally light composite Higgs boson, i.e., one whose mass M is much less than its binding scale Λ , and whose quartic coupling λ is large, so that its vacuum expectation value $v \sim M/\sqrt{\lambda} \ll \Lambda$ also. We consider two different underlying dynamics—UV completions—at the scale Λ for this model. We find that the expectation from dimensional deconstruction is not realized and that low-energy details depend crucially on the UV completion. In one case, $M \ll \Lambda$ and $\lambda \ll 1$; hence, $v \sim \Lambda$. In the other, λ can be large or small, but then so is M , and v is still $O(\Lambda)$.

DOI: 10.1103/PhysRevD.65.115001

PACS number(s): 12.10.Dm, 12.60.Cn, 14.80.Cp

I. INTRODUCTION

There has been considerable interest lately in a new approach to model building called “dimensional deconstruction.” There are two views of dimensional deconstruction. One, taken by Arkani-Hamed, Cohen, and Georgi (ACG) [1,2], is that certain four-dimensional theories look, for a range of energies, like higher-dimensional theories in which the compactified extra dimensions are discretized on a periodic lattice. ACG used this resemblance—particularly the topological similarity between the $d > 4$ components of gauge fields and certain four-dimensional Goldstone bosons, and the absence of divergent counterterms for gauge-invariant operators of dimension greater than d —to deduce the form, strength, and sensitivity to high-scale physics of phenomenologically important operators, such as mass terms and self-interactions. The other view is that of Hill and his collaborators [3–5], who assume the extra dimensions are real. They discretize the extra dimensions, too—to regulate the theory. This “transverse lattice” theory is expected to be in the same universality class as the continuum theory. In the view of Hill *et al.*, the connection between gauge field components and light Higgs scalars is also there—because they are the same thing—and so the allowed operators and their sensitivity to high-scale physics are unambiguous. The consequences of both of these views of dimensional deconstruction are similar, but they are not identical.

In this paper, we study ACG’s view as they apply it to building a model of electroweak symmetry breaking with light composite Higgs bosons [6]. In Ref. [2], ACG used dimensional deconstruction to deduce that certain pseudo Goldstone bosons (PGBs) acquire masses M much less than the energy scale at which they are formed, $\Lambda \approx 4\pi f$, where f is the PGB decay constant. They argued further that the PGBs have negative mass-squared terms $M_-^2 \sim -M^2$, and that their quartic interaction is strong yet does not contribute to M^2 . These ingredients—positive and negative squared

masses $M_+^2 \approx -M_-^2 \ll \Lambda^2$ and quartic couplings large compared to M_{\pm}^2/Λ^2 —are what is required for a light composite Higgs boson whose vacuum expectation value $v \sim M$ without fine-tuning. These PGBs are prototypes for electroweak Higgs bosons whose mass and vacuum expectation value (VEV) are *naturally* stabilized far below their binding-energy scale. This is important because it is the first natural scheme for electroweak symmetry breaking since the inventions of technicolor and supersymmetry over 20 years ago.

The simplest implementation of ACGs dimensional deconstruction for light composite Higgs bosons would be the naive one, which we dub the “principal of strict deconstruction”: For four-dimensional theories which admit a higher-dimensional interpretation, the form and strength of operators involving Goldstone bosons may be deduced from those for the corresponding $d > 4$ components of gauge fields. ACG certainly do not adopt such a strict formulation, for, as we will quickly see, it is incorrect. A more liberal formulation is needed. In this paper, we explore how much we must liberalize it in order to achieve the goal of a naturally light composite Higgs boson.

To that end, this paper is frankly pedagogical, containing many details of the calculation of PGB masses and couplings. We hope that some will find the pedagogy useful. For them, and for the experts, our bottom line is this: Sometimes dimensional deconstruction works and sometimes it does not. It often depends critically on the ultraviolet (UV) completion of the low-energy theory to which deconstruction is applied.

To make this more concrete, let us review the simplest example presented by ACG. In Ref. [1], they introduced a model containing N strong gauge groups $SU(n)_k$ and N weak ones $SU(m)_k$. The matter fields of this model are the massless chiral fermions,

$$\begin{aligned} \psi_{Lk} \in (n, m, 1), \quad \psi_{Rk} \in (n, 1, m) \\ \text{of } (SU(n)_k, SU(m)_k, SU(m)_{k+1}) \\ (k = 1, 2, \dots, N). \end{aligned} \quad (1)$$

The index k is periodically identified with $k + N$, making this the “moose ring” model depicted in Fig. 1. For simplicity,

*Email address: lane@physics.bu.edu

†Permanent address.

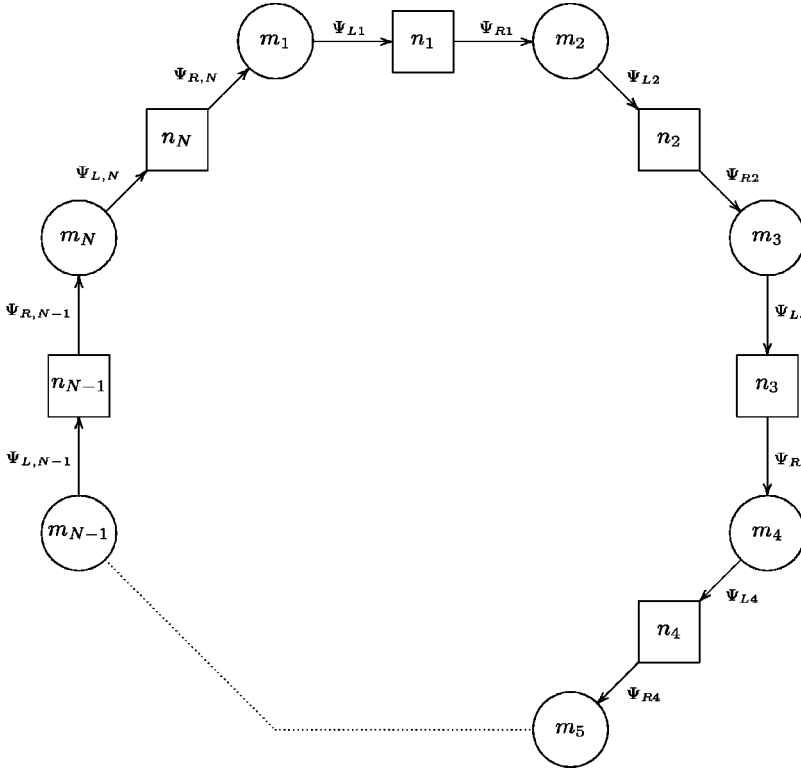

FIG. 1. The full moose for the ring model of Ref. [1], showing its UV completion. Strong gauge groups are labeled by n_1, n_2, \dots, n_N and weak gauge groups by m_1, m_2, \dots, m_N . Fermions ψ_{Lk} and ψ_{Rk} transform as $(n, m, 1)$ and $(n, 1, m)$ of $(\text{SU}(n)_k \otimes \text{SU}(m)_k \otimes \text{SU}(m)_{k+1})$.

all $\text{SU}(n)$ couplings g_s are taken equal. They become strong at the high-energy scale Λ . All $\text{SU}(m)$ couplings g are taken equal and assumed to be much less than g_s at Λ . This setup is the model's UV completion. Let us see how it evolves as we descend to lower energies.

At Λ , the strong $\text{SU}(n)$ interactions cause the fermions to condense as

$$\langle \Omega | \bar{\psi}_{Lk} \psi_{Rl} | \Omega \rangle = \langle \Omega | \bar{\psi}_{Rk} \psi_{Ll} | \Omega \rangle = -\delta_{kl} \Delta, \quad (2)$$

where $\text{SU}(m)$ indices are not summed over and $\Delta \simeq 4\pi f^3$. In the limit $g \rightarrow 0$, these fermions' interactions have a large chiral symmetry, $[\text{SU}(m)_L \otimes \text{SU}(m)_R]^N$. The symmetry of the ground state $|\Omega\rangle$ is the diagonal vectorial subgroup, $[\text{SU}(m)_V]^N$. Therefore, there are N sets of $m^2 - 1$ Goldstone bosons. They are the pseudoscalars π_k^a that couple to the axial vector currents $j_{5\mu, k}^a = \bar{\psi}_{Rk} \gamma_\mu t_a \psi_{Rk} - \bar{\psi}_{Lk} \gamma_\mu t_a \psi_{Lk}$ with strength $2f$. Here, t_a ($a=1, 2, \dots, m^2 - 1$) are generators in the fundamental representation of $\text{SU}(m)$ normalized to $\text{Tr}(t_a t_b) = \frac{1}{2} \delta_{ab}$.

Below Λ , this theory is described by nonlinear sigma model fields $U_k = \exp(i\pi_k^a t_a / f) \equiv \exp(i\pi_k / f)$ interacting with the weakly coupled $\text{SU}(m)_k$ gauge fields $A_{k\mu} = A_{k\mu}^a t_a$. The matter fields transform under the weak gauge groups as $U_k \rightarrow W_k U_k W_{k+1}^\dagger$. The effective Lagrangian is

$$\mathcal{L} = -\frac{1}{2g^2} \sum_{k=1}^N \text{Tr} F_{k\mu\nu} F_k^{\mu\nu} + f^2 \sum_{k=1}^N \text{Tr} [(D_\mu U_k)^\dagger D^\mu U_k], \quad (3)$$

where $D_\mu U_k = \partial_\mu U_k - iA_{k\mu} U_k + iU_k A_{k+1, \mu}$. This low-energy theory is described by the "condensed moose" in Fig.

2, with the link variables U_k connecting sites k and $k+1$. In this case, though not in all others, the moose describing the high-energy and low-energy theories look the same.

Now, $N-1$ of the gauge boson multiplets absorb $N-1$ sets of Goldstone bosons and acquire the masses $\mathcal{M}_k = 2gf \sin(k\pi/N)$ for $k=1, \dots, N$. The massless gauge field $A_\mu^a = (A_{1\mu}^a + \dots + A_{N\mu}^a) / \sqrt{N}$ couples with strength g/\sqrt{N} and the unabsorbed Goldstone boson is $\pi^a = (\pi_1^a + \dots + \pi_N^a) / \sqrt{N}$. In the unitary gauge, then, the four-dimensional theory below Λ is described by uniform link variables $U_k = \exp(i\pi^a t_a / \sqrt{N} f)$ plus the massless and massive gauge fields.

Alternatively, at energies well below gf , this looks exactly like a five-dimensional gauge theory. The fifth dimension is compactified on a discretized circle, represented exactly by the *condensed* moose, and there appears to be (for $k \ll N$) a Kaluza-Klein tower of excitations of the massless gauge boson [1]. The circumference of the circle is $R = Na$, where the lattice spacing $a = 1/gf$ and the five-dimensional gauge coupling is $g_5^2 = g^2 a$. The fifth component of the gauge boson $A_5^a = g \pi^a / \sqrt{N}$. The geometrical connection is clear: π^a is the zero mode associated with rotation about the circle of $\text{SU}(m)$ groups in four dimensions and it corresponds to the fifth-dimensional gauge freedom associated with A_5^a .

But π^a is a pseudo Goldstone boson; the symmetry corresponding to it is explicitly broken by the weak $\text{SU}(m)_k$ interactions. What does dimensional deconstruction tell us about its mass? As ACG state, the higher-dimensional gauge invariance forbids contributions to the mass of A_5 from energy scales greater than $1/R$, the inverse size of the fifth dimension. However, gauge invariance does allow a mass

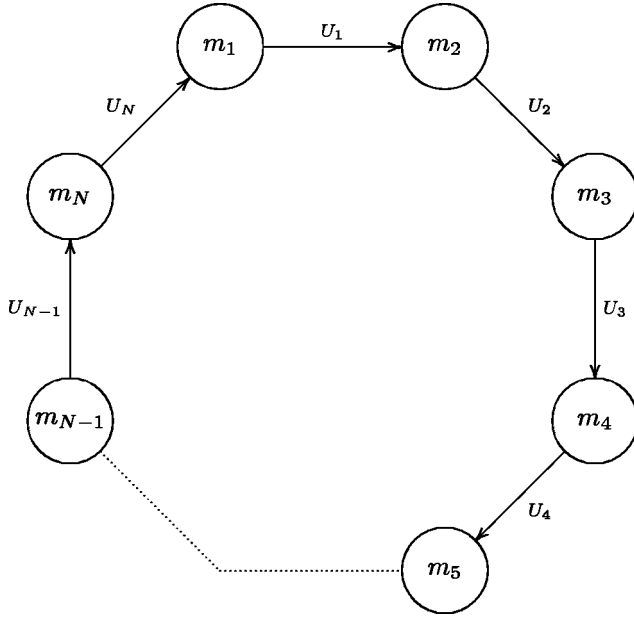

FIG. 2. The condensed moose for the ring model of Ref. [1], characterizing its low-energy structure with nonlinear sigma fields $U_k = \exp(i\pi_k/f)$ linking the weak groups $SU(m)_k$ and $SU(m)_{k+1}$.

term for A_5 from $|\mathcal{W}|^2$, where $\mathcal{W} = P \exp(i\int dx_5 A_5)$ is the nontrivial Wilson loop around the fifth dimension. Since $|\mathcal{W}|^2$ is a nonlocal operator, it cannot be generated with a UV-divergent coefficient. On the discretized circle, $\mathcal{W} = \text{Tr}[\prod_{k=1}^N \exp(iaA_{5k})]$. In the four-dimensional theory, this is just the gauge-invariant $\text{Tr}(U_1 U_2 \cdots U_N)$, and so this is what provides the mass for π^a . Standard power counting indicates that the strength of $|\text{Tr}(U_1 U_2 \cdots U_N)|^2$ is $\Lambda^2 f^2 (g^2/16\pi^2)^N$. This is correct only for $N=1$. For $N \geq 2$,

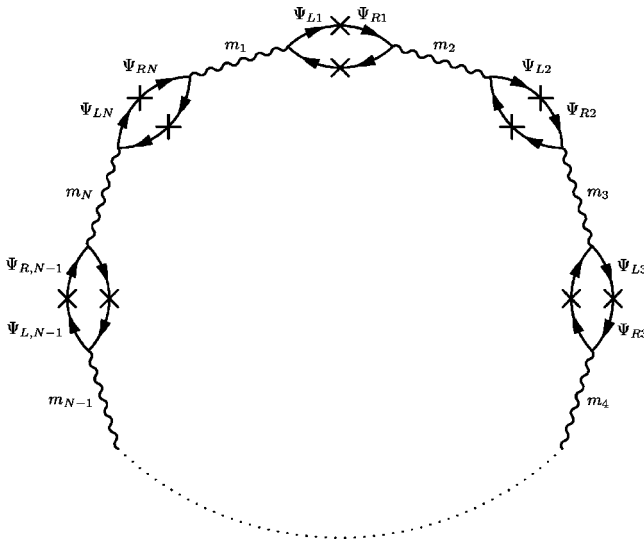

FIG. 3. Graphical depiction of the Hamiltonian \mathcal{H}_N in Eq. (5). Fermions transform as indicated in Eq. (1) under the weak gauge groups $SU(m)_k$, whose bosons are identified in the figure. An \times indicates a dynamical mass insertion. Strong $SU(n)$ gauge boson interactions within each fermion loop are not indicated. There are no strong gauge interactions between loops.

infrared singularities from the gauge boson masses at $g \rightarrow 0$ overrule this power counting. ACG show this using the Coleman-Weinberg potential for π^a . Contributions to the mass for $N=2$ come from the infrared to the ultraviolet regions, so that $M^2 \propto g^4 f^2 \log(\Lambda^2/\mathcal{M}_B^2) \sim g^4 f^2 \log(4\pi^2 N^2/g^2)$, where $\mathcal{M}_B^2 \sim g^2 f^2/N^2$ is a typical $SU(m)$ gauge boson mass; for $N \geq 3$, the IR region dominates and $M^2 \propto g^4 f^2$.

The same dependence of the g^2 power on N is readily seen by calculating M^2 from Dashen's formula [7]:

$$4f^2 M^2 \delta_{ab} = i^2 \langle \Omega | [Q_\pi^a, [Q_\pi^b, \mathcal{H}_N]] | \Omega \rangle. \quad (4)$$

The π^a chiral symmetry breaking Hamiltonian \mathcal{H}_N is depicted in Fig. 3 and is given by

$$\begin{aligned} \mathcal{H}_N \approx & i^{N+1} g^{2N} \int \frac{d^4 q}{(2\pi)^4} \left(\frac{1}{q^2} \right)^N \int \sum_{\{c\}=1}^{m^2-1} \prod_{k=1}^N \{d^4 x_k e^{iq \cdot x_k} g^{\mu_k \nu_k} \\ & \times T[j_{Lk\mu_k}^{c_k}(x_k) j_{Rk\nu_{k+1}}^{c_{k+1}}(0)]\}, \end{aligned} \quad (5)$$

where $j_{\lambda k \mu}^c = \bar{\psi}_{\lambda k} \gamma_\mu t_c \psi_{\lambda k}$. The infrared divergence in this Hamiltonian may be cut off by replacing the massless gauge propagators by $\prod_{k=1}^N (q^2 - \mathcal{M}_k^2)^{-1}$. This ‘‘round-the-world’’ Hamiltonian corresponds to the effective Wilson-loop interaction

$$\begin{aligned} \mathcal{H}_W = & \frac{C_W g^4}{16\pi^2} \sum_{\{c\}=1}^{m^2-1} \prod_{k=1}^N \text{Tr}(t_{c_k} U_k t_{c_{k+1}} U_k^\dagger) \\ = & \frac{C_W g^4}{2^N 16\pi^2} |\text{Tr}(U_1 U_2 \cdots U_N)|^2, \end{aligned} \quad (6)$$

where $C_W = O[\log(4\pi^2/g^2)]$ for $N=2$ and $O(1)$ for $N \geq 3$.

If $g^2/4\pi \sim 10^{-2}$ in this moose ring model, the PGB is much lighter than its underlying compositeness scale Λ . Unfortunately, it cannot be used as a light composite Higgs boson with $v \sim M$ because its quartic self-interactions are all too weak, either derivatively coupled and of order $p^4/f^4 \sim g^8$ for typical momentum $p \sim M$, or induced directly by the weak gauge interactions as in \mathcal{H}_W and of order g^4 . This is in accord with what would be expected from dimensional deconstruction with its A_5 interpretation of π . To overcome this, ACG went to a six-dimensional model with nonderivative PGB interactions. We consider this model in the rest of this paper.

In Sec. II, we describe ACGs model in which the condensed moose diagram is the discretization of a torus with $SU(m)$ gauge groups (weak coupling g) at $N \times N$ sites connected by nonlinear sigma model links. This corresponds to a six-dimensional gauge model with the fifth and sixth dimensions compactified on the torus. In the four-dimensional view of the model, the Higgs mechanism gives mass to all but one of the $SU(m)$ gauge multiplets, and several PGBs remain to get mass and mutually interact. Two of these correspond to the fifth and sixth components of the gauge field; the others do not have such simple topological interpretations. We discuss the expectations from strict dimensional deconstruction for the PGB masses and interactions and show, in particular,

that the quartic interaction of the PGBs corresponding to $A_{5,6}$ should be $O(g^2/N^2)$. This is not strong, but it may be large enough compared to M^2/Λ^2 to give $v \sim M \ll \Lambda$. We present a UV completion of this model consisting of a QCD-like dynamics of fermions with strong gauge interactions, just as ACG did for the five-dimensional moose ring model. Then, for simplicity and for its phenomenological relevance [8], we restrict this model to $N=2$. It has five composite PGB multiplets. In Sec. III, we estimate the PGB masses, identifying the structure of the leading $g^4 \log(1/g^2)$ and g^4 contributions to M^2 . The $g^4 \log(1/g^2)$ terms are the same as in the moose ring model and their form is predicted by dimensional deconstruction. At that order, one of the PGBs *not* corresponding to $A_{5,6}$ remains massless. When $O(g^4)$ terms are added, all five PGBs have comparable mass. In Sec. IV, we consider the nonderivative interactions of the PGBs. The interactions produced by the QCD-like UV completion have neither the form nor the strength of those predicted by dimensional deconstruction. In particular, the interactions are $O(g^4)$, too weak to give a Higgs VEV comparable to its mass. In Sec. V, we study a UV completion that adds elementary scalars interacting strongly with themselves and the fermions. These induce the PGB strong self-interactions expected from dimensional deconstruction. However, for $N=2$ these scalar interactions also give large masses to *all* the PGBs. At the least, this changes the low-energy phenomenology of the model; at worst, it eliminates the candidates for a light composite Higgs boson. This difficulty of constructing light composite Higgs bosons seems to be general: The desired quartic interactions explicitly break the symmetries keeping the PGBs light. If the interactions are strong, the PGBs are not PGBs at all, and conversely. In any case, what happens depends critically on the condensed-moose theory's UV completion.

II. THE $d=6$ TOROIDAL MOOSE MODEL

In Ref. [2], ACG considered a model in which the condensed moose is the discretization of a torus with $N \times N$ sites; see Fig. 4. The sites are labeled by integers (k, l) with k identified with $k+N$ and l with $l+N$. The weakly coupled gauge groups $SU(m)_{kl}$ (all with coupling g) are located at the sites. The sites are linked by U_{kl} and V_{kl} . They connect the sites (k, l) to $(k, l+1)$ and to $(k+1, l)$, respectively, according to the $SU(m)_{kl}$ transformations,

$$U_{kl} \rightarrow W_{kl} U_{kl} W_{k,l+1}^\dagger, \quad V_{kl} \rightarrow W_{kl} V_{kl} W_{k+1,l}^\dagger. \quad (7)$$

In the four-dimensional theory, the link variables are nonlinear sigma model fields involving $2N^2$ $SU(m)$ adjoints of composite Goldstone bosons, $\pi_{u,kl} = \sum_a \pi_{u,kl}^a t_a$ and $\pi_{v,kl} = \sum_a \pi_{v,kl}^a t_a$:

$$U_{kl} = \exp(i\pi_{u,kl}/f), \quad V_{kl} = \exp(i\pi_{v,kl}/f). \quad (8)$$

The $SU(m)_{kl}$ gauge bosons absorb $N^2 - 1$ sets of GBs. From the covariant derivatives,

$$D^\mu U_{kl} = \partial^\mu U_{kl} - iA_{kl}^\mu U_{kl} A_{k,l+1}^\mu, \quad (9)$$

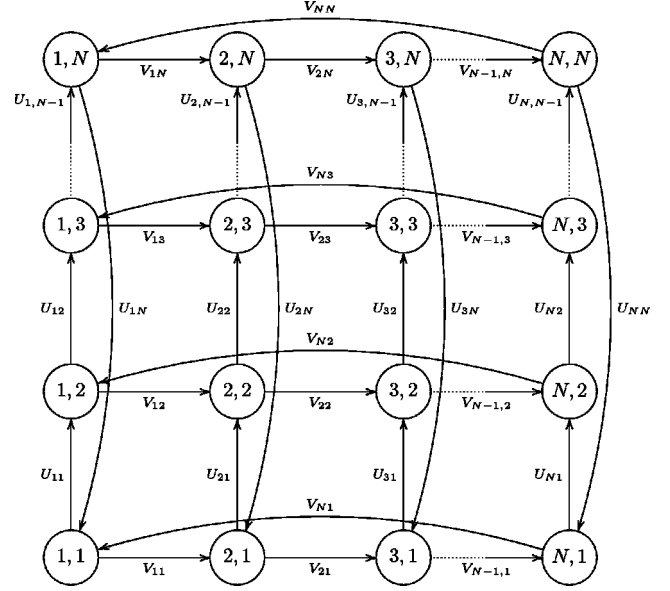

FIG. 4. The condensed moose for the toroidal model of Ref. [2]. The weak $SU(m)_{kl}$ group is denoted by a circle at the site (k, l) . The site (k, l) is identified with the sites $(k+N, l)$ and $(k, l+N)$. Nonlinear sigma model link fields U_{kl} and V_{kl} transform according to Eq. (7).

$$D^\mu V_{kl} = \partial^\mu V_{kl} - iA_{kl}^\mu V_{kl} + iV_{kl} A_{k+1,l}^\mu,$$

it is easy to determine that the mass eigenstate vector bosons and their masses are

$$\begin{aligned} B_{mn}^\mu &= \sum_{k,l} (\zeta_{mn}^*)_{(kl)} A_{kl}^\mu \\ &\equiv \frac{1}{N} \sum_{k,l} e^{-2i(km+ln)\pi/N} A_{kl}^\mu, \\ \mathcal{M}_{B,mn}^2 &= 4g^2 f^2 \left[\sin^2\left(\frac{m\pi}{N}\right) + \sin^2\left(\frac{n\pi}{N}\right) \right] \\ &\quad (m, n = 1, \dots, N). \end{aligned} \quad (10)$$

The massless gauge boson is $B_{NN}^\mu = N^{-1} \sum_{k,l} A_{kl}^\mu$ and its coupling is g/N .

Among the $N^2 + 1$ leftover PGBs, two that are especially interesting are

$$\pi_u = \frac{1}{N} \sum_{k,l} \pi_{u,kl}, \quad \pi_v = \frac{1}{N} \sum_{k,l} \pi_{v,kl}. \quad (11)$$

These are the analogs of π in the moose ring model, the zero modes associated with going around the torus in the U and V directions. ACG used these two PGBs as light composite Higgs multiplets.¹

¹In Ref. [2], the weak groups are all $SU(3)$ except at the $(1,1)$ site, where it is only the $SU(2) \otimes U(1)$ subgroup of $SU(3)$. This stratagem gets the putative Higgs bosons out of the adjoint and into $SU(2)$

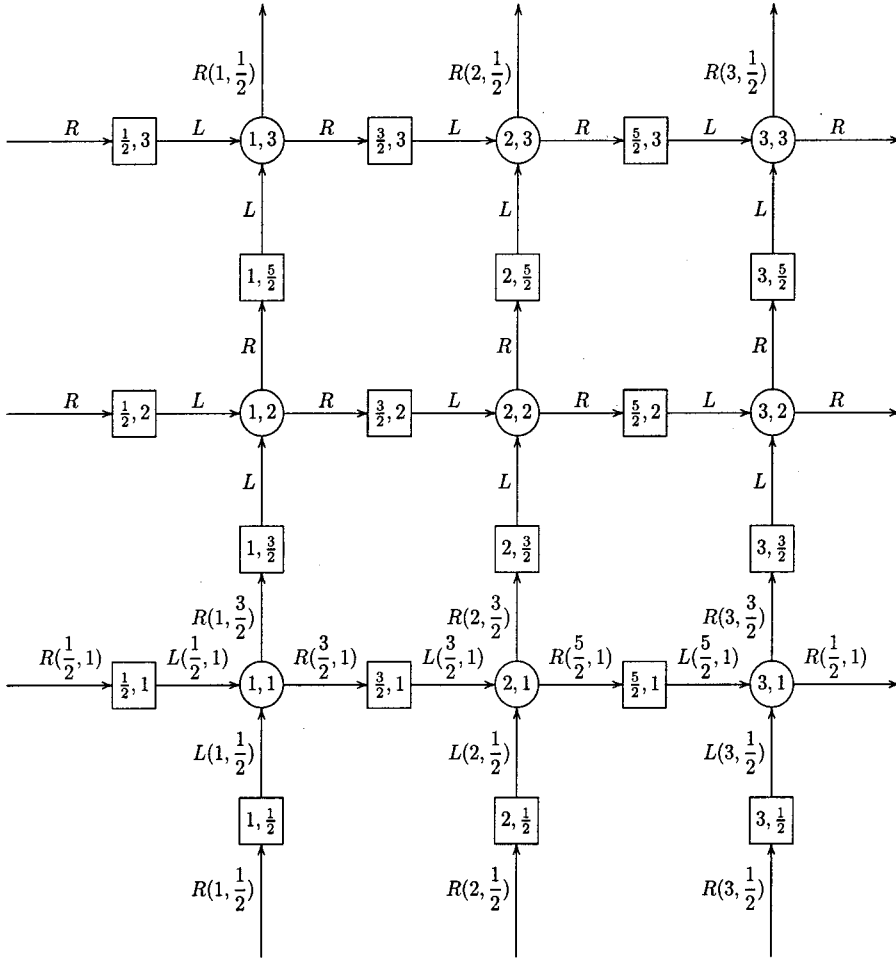

FIG. 5. The complete moose for the toroidal model of Ref. [2] with a QCD-like UV completion. The weak $SU(m)_{kl}$ gauge groups are as in Fig. 4, and the strong $SU(k-\frac{1}{2}, l)$ and $SU(k, l-\frac{1}{2})$ gauge groups are indicated by squares. Fermions transform as in Eq. (17).

What do we expect for the masses and couplings of π_u and π_v from dimensional deconstruction? Viewing the condensed moose as the compactified fifth and sixth dimensions of a six-dimensional gauge theory, the toroidal circumference once again is $R=Na$ with $a=1/gf$, the gauge coupling is $g_6=g_a$, and the extra-dimensional gauge fields are $A_{5,6}^a = g \pi_{u,v}^a/N$. As in the moose ring model, dimensional deconstruction tells us that the leading contributions to their masses come from the Wilson loops around the fifth and sixth dimensions, e.g.,

$$\begin{aligned}
 |\mathcal{W}_5|^2 &= \left| P \exp \left(i \int dx_5 A_5 \right) \right|^2 \\
 &= \left| \text{Tr} \left\{ \prod_{l=1}^N \exp(iaA_{5kl}) \right\} \right|^2 \\
 &= |\text{Tr}[\exp(i\pi_u/Nf)]^N|^2 \\
 &= |\text{Tr}(U_{kl} \cdots U_{kN})|^2 \quad (k=1, \dots, N). \quad (12)
 \end{aligned}$$

Thus, as in the five-dimensional model, we expect $M_{\pi_{u,v}}^2 \propto g^4 f^2 \log(4\pi^2 N^2/g^2)$ for $N=2$ and $g^4 f^2$ for $N \geq 3$. The last

equality in Eq. (12) assumes that $\pi_{u,v}$ are the only light PGBs, so that $U_{kl} \cong \exp(i\pi_u/Nf)$ and $V_{kl} \cong \exp(i\pi_v/Nf)$ at low energies. We shall see in the next section that this is not always true; the PGB masses depend on the nature of the theory's UV completion.

The quartic self-interactions of the PGBs of the moose ring model are weak, at most $O(g^4)$. In the six-dimensional gauge model, dimensional deconstruction implies the existence of a stronger nonderivative interaction corresponding to

$$\begin{aligned}
 \text{Tr} F_{56}^2 &= \text{Tr}([A_5, A_6]^2) + \cdots \\
 &= \lambda \text{Tr}([\pi_u, \pi_v]^2) + \cdots. \quad (13)
 \end{aligned}$$

This interaction comes from the plaquette operators [2]

$$\mathcal{H}_{\square} = \sum_{k,l} \lambda_{kl} f^4 \text{Tr}(U_{kl} V_{k,l+1} U_{k+1,l}^\dagger V_{kl}^\dagger) + \text{H.c.} \quad (14)$$

Note that \mathcal{H}_{\square} does not contribute to the $\pi_{u,v}$ masses. The strength of the $\text{Tr}([\pi_u, \pi_v]^2)$ term is $\lambda = \frac{1}{2} \sum_{k,l} \lambda_{kl} / N^4$. The λ_{kl} are fixed by dimensional deconstruction as follows:² The six-dimensional action including the nonderivative term in Eq. (13) is

doublets where they belong. We shall not need to complicate our exposition by inserting a weak gauge defect at one site.

²I thank Bill Bardeen for this argument.

$$\int d^4x a^2 \frac{1}{g_6^2} \left[\sum_{\mu, \nu=1}^4 F_{\mu\nu}^2 + \frac{1}{a^4} \sum_{k,l} \text{Tr}(U_{kl} V_{k,l+1} U_{k+1,l}^\dagger V_{kl}^\dagger) + \text{mixed terms} \right]. \quad (15)$$

This gives $\lambda_{kl} = (f^4 g_6^2 a^2)^{-1} = g^2$ and

$$\lambda = \frac{g^2}{2N^2}. \quad (16)$$

This may or may not be large enough to give a Higgs VEV v comparable to $M_{\pi_{u,v}}$, depending on the N dependence of the Higgs masses.

The question of whether we can realize Eq. (16) is a major focus of this paper. We pose the question as follows: Can we construct a UV completion of the condensed moose that generates $\text{Tr}([\pi_u, \pi_v]^2)$ with strength $O(g^2/N^2)$? Below we present a QCD-like UV completion. We find that this produces $\lambda = O(g^4)$, and a VEV of $O(\Lambda)$. In Sec. V we study a completion involving strongly interacting elementary scalars. It also fails to produce the desired hierarchy of M , v , and Λ . While we have not proved that no UV completion exists which realizes the expectation of deconstruction, we expect this is so. In any event, the outcome of the low-energy Higgs theory depends crucially on its UV completion.

The simplest UV completion of this model, and the one we shall adopt in the next two sections, follows the strategy of the moose ring model and is based on QCD-like dynamics at the scale $\Lambda \simeq 4\pi f$. Since the link variables involve $2N^2$ Goldstone bosons $\pi_{u,kl}$ and $\pi_{v,kl}$, we assume there are $2N^2$ strongly coupled $SU(n)$ gauge groups. These are located at sites $(k, l + \frac{1}{2})$ and $(k + \frac{1}{2}, l)$ for $k, l = 1, \dots, N$. The strongly interacting massless fermions of this model are

$$\begin{aligned} \psi_{R(k,l+1/2)} &\in (n, m, 1), \quad \psi_{L(k,l+1/2)} \in (n, 1, m) \\ &\text{of } (SU(n)_{k,l+1/2}, SU(m)_{kl}, SU(m)_{k,l+1}), \\ \psi_{R(k+1/2,l)} &\in (n, m, 1), \quad \psi_{L(k+1/2,l)} \in (n, 1, m) \\ &\text{of } (SU(n)_{k+1/2,l}, SU(m)_{kl}, SU(m)_{k+1,l}). \end{aligned} \quad (17)$$

The UV-completed toroidal moose is shown in Fig. 5.

These fermion interactions are invariant under an $[SU(m)_L \otimes SU(m)_R]^{2N^2}$ chiral symmetry. Strong $SU(n)$ dynamics cause the condensates

$$\begin{aligned} \langle \Omega | \bar{\psi}_{L(k,l+1/2)} \psi_{R(m,n+1/2)} | \Omega \rangle &= -\delta_{km} \delta_{ln} \Delta \\ &\leftrightarrow 4\pi f^2 U_{kl} \delta_{km} \delta_{ln}, \\ \langle \Omega | \bar{\psi}_{L(k+1/2,l)} \psi_{R(m+1/2,n)} | \Omega \rangle &= -\delta_{km} \delta_{ln} \Delta \\ &\leftrightarrow 4\pi f^3 V_{kl} \delta_{km} \delta_{ln}, \end{aligned} \quad (18)$$

so that this symmetry breaks spontaneously to the diagonal $[SU(m)_V]^{2N^2}$ subgroup with the appearance of the $\pi_{u,v,kl}$.

From now on, we restrict ourselves to the case $N=2$, partly for the phenomenological reason noted earlier and partly because of its simplicities and peculiarities. The full and condensed $N=2$ moose are shown in Fig. 6. Note that every pair of adjacent lattice sites in the condensed moose are connected by two link variables, U_{kl} and $U_{k,l+1}$ or V_{kl} and $V_{k+1,l}$. The gauge boson masses are $\mathcal{M}_{11}^2 = 8g^2 f^2$, $\mathcal{M}_{12}^2 = \mathcal{M}_{21}^2 = 4g^2 f^2$, and $\mathcal{M}_{22}^2 = 0$.

From Eq. (10) and the fermion $SU(m)_{kl}$ current,

$$\begin{aligned} j_{u,kl}^a &= j_{R\mu(k,l+1/2)}^a + j_{L\mu(k,l-1/2)}^a + j_{R\mu(k+1/2,l)}^a \\ &\quad + j_{L\mu(k-1/2,l)}^a, \end{aligned} \quad (19)$$

we read off the Goldstone boson $\pi_{(mn)}$ absorbed by B_{mn}^μ :

$$\begin{aligned} \pi_{(mn)}^a &= \frac{1}{2} \sum_{k,l=1}^2 (\zeta_{(mn)})_{(kl)} [\pi_{u,kl}^a - \pi_{u,k,l-1}^a + \pi_{v,kl}^a \\ &\quad - \pi_{v,k-1,l}^a]. \end{aligned} \quad (20)$$

A convenient basis for the five physical GBs, whose masses and couplings we will estimate in the next two sections, is

$$\begin{aligned} \pi_u &= \frac{1}{2} [\pi_{u,11} + \pi_{u,12} + \pi_{u,21} + \pi_{u,22}], \\ \pi_v &= \frac{1}{2} [\pi_{v,11} + \pi_{v,21} + \pi_{v,12} + \pi_{v,22}], \\ \pi'_u &= \frac{1}{2} [\pi_{u,11} + \pi_{u,12} - \pi_{u,21} - \pi_{u,22}], \\ \pi'_v &= \frac{1}{2} [\pi_{v,11} + \pi_{v,21} - \pi_{v,12} - \pi_{v,22}], \\ \pi'_{uv} &= \frac{1}{2} [\pi_{u,11} + \pi_{u,22} - \pi_{u,12} - \pi_{u,21} \\ &\quad - (\pi_{v,11} + \pi_{v,22} - \pi_{v,12} - \pi_{v,21})]. \end{aligned} \quad (21)$$

The inverse transformations, which are useful when expanding plaquette interactions, are

$$\begin{aligned} \pi_{u,11} &= \frac{1}{2} \left[\pi_u + \pi'_u + \pi_{(21)} + \frac{1}{\sqrt{2}} (\pi'_{uv} + \pi_{(11)}) \right], \\ \pi_{u,12} &= \frac{1}{2} \left[\pi_u + \pi'_u - \pi_{(21)} - \frac{1}{\sqrt{2}} (\pi'_{uv} + \pi_{(11)}) \right], \\ \pi_{u,21} &= \frac{1}{2} \left[\pi_u - \pi'_u + \pi_{(21)} + \frac{1}{\sqrt{2}} (\pi'_{uv} + \pi_{(11)}) \right], \\ \pi_{u,22} &= \frac{1}{2} \left[\pi_u - \pi'_u - \pi_{(21)} + \frac{1}{\sqrt{2}} (\pi'_{uv} + \pi_{(11)}) \right]; \\ \pi_{v,11} &= \frac{1}{2} \left[\pi_v + \pi'_v + \pi_{(12)} - \frac{1}{\sqrt{2}} (\pi'_{uv} - \pi_{(11)}) \right], \\ \pi_{v,21} &= \frac{1}{2} \left[\pi_v + \pi'_v - \pi_{(12)} + \frac{1}{\sqrt{2}} (\pi'_{uv} - \pi_{(11)}) \right], \end{aligned} \quad (22)$$

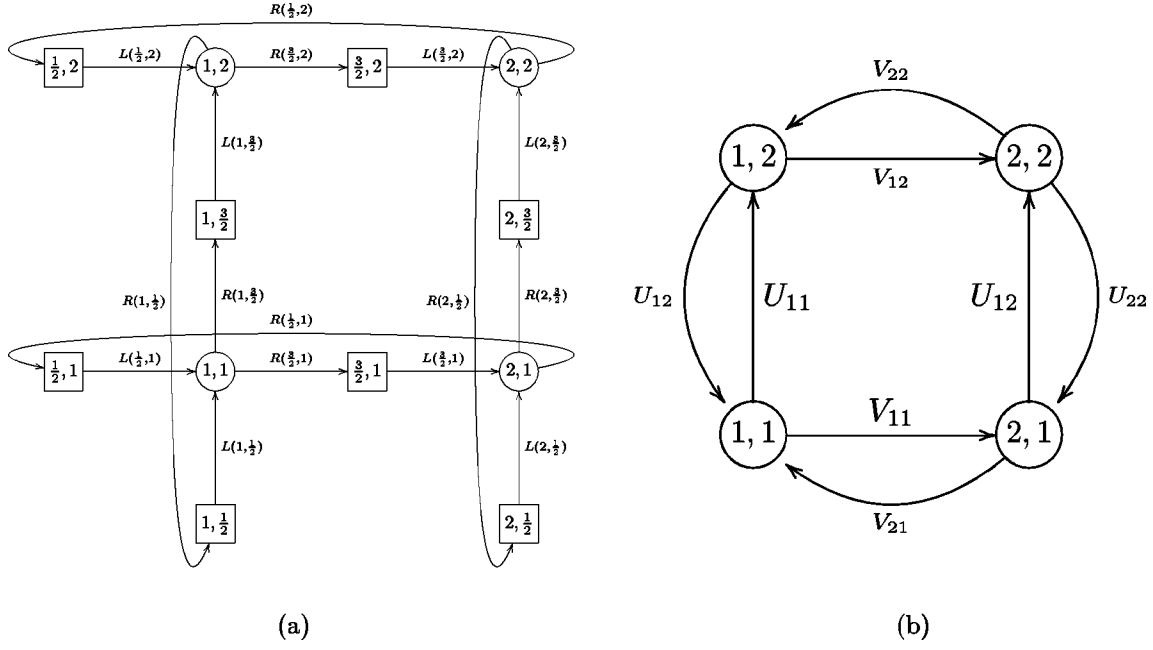

FIG. 6. The full (a) and condensed (b) moose for the $N=2$ toroidal model of Ref. [2] with a QCD-like UV completion. Notation is as in Figs. 4 and 5.

$$\pi_{v,12} = \frac{1}{2} \left[\pi_v - \pi'_v + \pi_{(12)} + \frac{1}{\sqrt{2}} (\pi'_{uv} - \pi_{(11)}) \right],$$

$$\pi_{v,22} = \frac{1}{2} \left[\pi_v - \pi'_v - \pi_{(12)} - \frac{1}{\sqrt{2}} (\pi'_{uv} - \pi_{(11)}) \right].$$

III. PSEUDO GOLDSTONE BOSON MASSES

As in the moose ring model for $N=2$, the leading $g^4 \log(1/g^2)$ contribution to the PGB masses comes from four distinct round-the-world graphs of the type shown in Fig. 7. The Hamiltonian, analogous to \mathcal{H}_N in Eq. (5), is

$$\begin{aligned} \mathcal{H}_2 \approx & i g^4 \int \frac{d^4 q}{(2\pi)^4} \left(\frac{1}{q^2} \right)^4 \int d^4 x d^4 y e^{iq \cdot (x+y)} g^{\mu\nu} g^{\lambda\rho} \sum_{c,d=1}^{m^2-1} \sum_{k=1}^2 [T(j_{R\mu}^c(k,1/2)(x)) j_{L\lambda}^d(k,1/2)(0)) \\ & \times T(j_{R\rho}^d(k,3/2)(y)) j_{L\nu}^c(k,3/2)(0)) + (k,1/2) \leftrightarrow (l/2,k)]. \end{aligned} \quad (23)$$

This corresponds to the effective interaction

$$\begin{aligned} \mathcal{H}_2 = & - \frac{C_2 f^4 g^4}{32 \pi^2} \log \left(\frac{4 \pi^2}{g^2} \right) \sum_{c,d=1}^{m^2-1} \sum_{k,l=1}^2 [\text{Tr}(t_c U_{kl} t_d U_{kl}^\dagger) \text{Tr}(t_c U_{k,l+1}^\dagger t_d U_{k,l+1}) + (U_{kl} \rightarrow V_{lk})] \\ = & - \frac{C_2 f^4 g^4}{128 \pi^2} \log \left(\frac{4 \pi^2}{g^2} \right) \sum_{k,l=1}^2 [|\text{Tr}(U_{kl} U_{k,l+1})|^2 + (U_{kl} \rightarrow V_{lk})], \end{aligned} \quad (24)$$

where we will see that $C_2 \approx 6$.

We can estimate the IR-singular contributions to the PGB masses by the classic method of current algebra combined with Weinberg's spectral function sum rules [9,10]. As in QCD, we assume the vector-axial vector spectral function Δ_{VA} can be saturated with a massless pseudoscalar and a single vector and axial vector meson of masses $M_{V,A} \approx \Lambda$ and dimensionless couplings $f_{V,A}$ to the (V, A) currents. This

gives

$$\begin{aligned} \Delta_{VA} = & \frac{f_V^2 M_V^2}{q^2 - M_V^2} - \frac{f_A^2 M_A^2}{q^2 - M_A^2} - \frac{4f^2}{q^2} \\ = & \frac{f_V^2 M_V^4}{q^2} \left(\frac{1}{q^2 - M_V^2} - \frac{1}{q^2 - M_A^2} \right). \end{aligned} \quad (25)$$

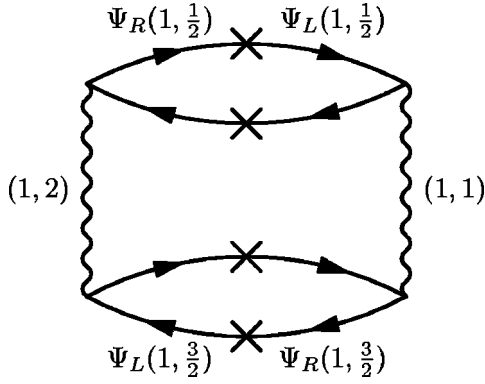

FIG. 7. Graphical depiction of a typical term in the Hamiltonian \mathcal{H}_2 in Eq. (23). Fermions transform as indicated in Fig. 6(a) under the weak gauge groups $SU(m)_{kl}$, whose bosons are identified in the figure. An \times indicates a dynamical mass insertion. As in Fig. 3, strong $SU(n)$ gauge boson interactions within each fermion loop are not indicated and there are no strong gauge interactions between loops.

The second equality follows from the spectral function sum rules,

$$\begin{aligned} f_V^2 M_V^2 - f_A^2 M_A^2 &= 4f^2, \\ f_V^2 M_V^4 - f_A^2 M_A^4 &= 0. \end{aligned} \quad (26)$$

We obtain

$$\begin{aligned} (M_{\pi_{u,v}}^2)_{g^4} \log g^2 &= (M_{\pi'_{u,v}}^2)_{g^4} \log g^2 \\ &\simeq \frac{3m g^4 f^2}{32\pi^2} \log\left(\frac{4\pi^2}{g^2}\right), \end{aligned} \quad (27)$$

where we put $\log(M_V^2/M_B^2) = \log(4\pi^2/g^2)$ for a typical $SU(m)$ gauge mass of $4g^2 f^2$ and used $f_V^2 M_V^2 (M_A^2 - M_V^2)/4f^2 = 1$ from Eq. (26). We read off

$$C_2 \simeq 6. \quad (28)$$

All mixing terms vanish and $(M_{\pi'_{uv}}^2)_{g^4} \log g^2 = 0$. In other words, dimensional deconstruction again predicts the origin but not the magnitude of the leading contribution to the $\pi_{u,v}$ masses. It fails to mention the $\pi'_{u,v}$ and the fact that they are degenerate with $\pi_{u,v}$. It completely misses the π'_{uv} and its masslessness at order $g^4 \log(1/g^2)$.

All the PGBs, including $\pi'_{u,v}$, get masses from 16 one-loop graphs of the type shown in Fig. 8. Because of infrared singularities, these are actually $O(g^4)$. They are represented by the $SU(m)$ -invariant effective Hamiltonian

$$\begin{aligned} \mathcal{H}_4 = & -\frac{C_4 g^4 f^4}{16\pi^2} \sum_{k,l=1}^2 \{ |\text{Tr}(U_{kl} V_{k,l+1} U_{k+1,l}^\dagger V_{kl}^\dagger)|^2 \\ & + |\text{Tr}(U_{kl} V_{k,l+1} U_{k+1,l+1} V_{kl}^\dagger)|^2 \\ & + |\text{Tr}(U_{kl} V_{k,l+1} U_{k+1,l}^\dagger V_{k+1,l})|^2 \} \end{aligned}$$

$$\begin{aligned} & + \frac{1}{2} |\text{Tr}(U_{kl} V_{k,l+1} U_{k+1,l+1} V_{k+1,l})|^2 \\ & + \frac{1}{2} |\text{Tr}(U_{kl} V_{k+1,l+1} U_{k+1,l}^\dagger V_{kl}^\dagger)|^2 \}. \end{aligned} \quad (29)$$

Note that these terms are invariant under the interchanges $U_{kl} \leftrightarrow V_{lk}$. The first four terms in \mathcal{H}_4 are the sum of the *squares* of the plaquette interaction \mathcal{H}_\square in Eq. (14). The other terms are allowed by gauge invariance for $N=2$ and have exactly the same strength.³ We will discuss in Sec. IV why the linear plaquette interaction does not appear.

The PGB masses from \mathcal{H}_4 are easily evaluated. There is no mixing in the sum of the terms and we find

$$\begin{aligned} (M_{\pi_u}^2)_{g^4} &= (M_{\pi_v}^2)_{g^4} = \frac{m C_4 g^4 f^2}{2\pi^2}, \\ (M_{\pi'_u}^2)_{g^4} &= (M_{\pi'_v}^2)_{g^4} = \frac{3m C_4 g^4 f^2}{4\pi^2}, \\ (M_{\pi'_{uv}}^2)_{g^4} &= \frac{2m C_4 g^4 f^2}{\pi^2}. \end{aligned} \quad (30)$$

We estimate C_4 by replacing the four massless gauge propagators in Fig. 8 by the mass eigenstate product $\Pi_{k,l}(q^2 - \mathcal{M}_{kl}^2)^{-1}$ and using the spectral functions Δ_{VA} :

$$C_4 \simeq \frac{3}{16} (1 - \log 2). \quad (31)$$

It is easy to see from Eq. (29) where the ratio $(M_{\pi_{u,v}}^2)_{g^4} : (M_{\pi'_{u,v}}^2)_{g^4} : (M_{\pi'_{uv}}^2)_{g^4} = 8 : 12 : 32$ comes from. Just set all PGB fields but the one in question to zero and expand to $O((\pi)^2)$.

Let us estimate the ratio of the two contributions to $M_{\pi_u}^2$. We take $g^2/4\pi = 1/30$. Then $(M_{\pi_u}^2)_{g^4} \log g^2 / (M_{\pi'_{uv}}^2)_{g^4} \simeq 15 \simeq 2(M_{\pi'_{uv}}^2)_{g^4} / (M_{\pi_u}^2)_{g^4}$; i.e., all the PGBs have roughly the same mass. With this QCD-like UV completion of the toroidal moose model, then, there are *five* sets of light PGBs and a very rich phenomenology. This does not change if there is a gauge defect with $SU(2) \otimes U(1)$ at site $(1, 1)$. Nor does the situation change qualitatively for $N > 2$. In sum, the particle spectrum of the six-dimensional gauge theory is not a very good representation of the four-dimensional one at energies well below Λ .

IV. PSEUDO GOLDSTONE SELF-INTERACTIONS

Deconstructing the six-dimensional toroidal moose led us to expect the nonderivative interaction $\text{Tr}([\pi_u, \pi_v])^2$ with strength g^2/N^2 . It was to come from the lattice version of $\int g_6^{-2} \text{Tr} F_{56}^2$, namely, $g^2 \sum_{k,l} \text{Tr}(U_{kl} V_{k,l+1} U_{k+1,l}^\dagger V_{kl}^\dagger)$. Instead, our QCD-style UV completion of the model produced the squared, not the linear, plaquette interaction \mathcal{H}_4 . Its $O(g^4)$ coupling is too weak to produce a light composite Higgs VEV much less than Λ .

³This $N=2$ case is special. In an $N \times N$ toroidal lattice with periodic boundaries, there are N^2 plaquettes for $N \geq 3$.

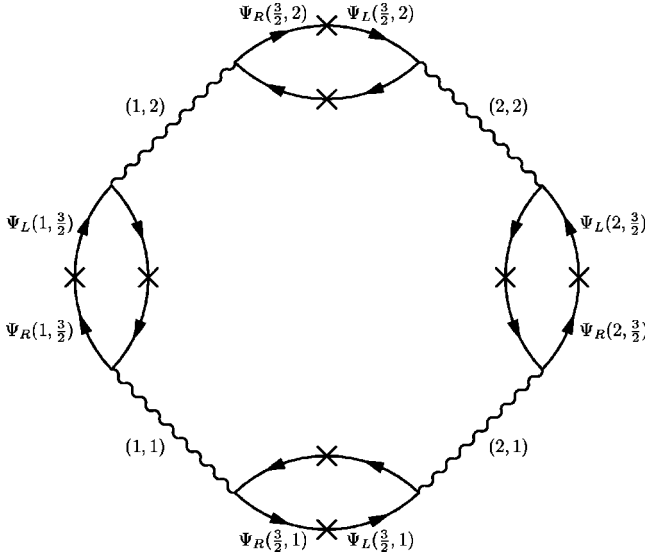

FIG. 8. Typical graph contributing to the Hamiltonian \mathcal{H}_4 in Eq. (29). The notation is as in Fig. 7.

The linear interaction does not appear for *any* N because this theory is invariant under reflection of any and all fermion fields $\psi_{L,R}$ and, hence, under the reflection of any U_{kl} and any V_{kl} . This by itself does not preclude the existence of $\text{Tr}([\pi_u, \pi_v])^2$, which indeed appears in the expansion of $|\text{Tr}(UVU^\dagger V^\dagger)|^2$. However, for the phenomenologically interesting case of $N=2$, even this interaction and many others like it are absent, at least to $O(g^4)$. This follows from the invariance of \mathcal{H}_4 under the replacement of any single U_{kl} by $U_{k,l+1}^\dagger$ or V_{kl} by $V_{k+1,l}^\dagger$. Thus, interactions arising from \mathcal{H}_4 are invariant under any *one* replacement of the type

$$\begin{aligned} \pi_u \pm \pi'_u \pm \frac{1}{\sqrt{2}} \pi'_{uv} &\rightarrow -(\pi_u \pm \pi'_u) \pm \frac{1}{\sqrt{2}} \pi'_{uv}, \\ \pi_v \pm \pi'_v \pm \frac{1}{\sqrt{2}} \pi'_{uv} &\rightarrow -(\pi_v \pm \pi'_v) \pm \frac{1}{\sqrt{2}} \pi'_{uv}. \end{aligned} \quad (32)$$

Eight $\text{Tr}([\pi_u, \pi_v])^2$ terms in \mathcal{H}_4 are canceled by eight $\text{Tr}([\pi_u, \pi_v][\pm \pi_u, \mp \pi_v])$ terms.

This is not to say that all quartic PGB interactions in \mathcal{H}_4 vanish; they do not. But for our UV completion of the $N=2$ toroidal moose, the term expected from dimensional deconstruction just is not there. This is an artifact of $N=2$; $\text{Tr}([\pi_u, \pi_v])^2$ does appear for higher N . But its coupling and that of all other nonderivative quartic interactions are still $O(g^4)$. In the next section, we change the UV completion of the model to obtain stronger quartic interactions.

V. STRONGER INTERACTIONS FROM ELEMENTARY SCALARS

Linear plaquette interactions of any strength can be obtained by adding strongly interacting scalar fields to the UV

completion of the toroidal moose model.⁴ We introduce eight complex scalar field multiplets, $\phi_{u,kl}$ and $\phi_{v,kl}$ for $k, l = 1, 2$, all of which are strong $SU(n)$ singlets:

$$\begin{aligned} \phi_{u,kl} &\equiv \frac{1}{\sqrt{2m}} \phi_{u,kl}^0 + \sum_{a=1}^{m^2-1} \phi_{u,kl}^a t_a \in (m, \bar{m}) \\ &\text{of } SU(m)_{kl} \otimes SU(m)_{k,l+1}, \\ \phi_{v,kl} &\equiv \frac{1}{\sqrt{2m}} \phi_{v,kl}^0 + \sum_{a=1}^{m^2-1} \phi_{v,kl}^a t_a \in (m, \bar{m}) \\ &\text{of } SU(m)_{kl} \otimes SU(m)_{k+1,l}, \end{aligned} \quad (33)$$

i.e., the $\phi_{u,kl}$ transform like U_{kl} and the $\phi_{v,kl}$ like V_{kl} . To maintain equality of the weak $SU(m)_{kl}$ coupling g , we require all scalar interactions to be site-symmetric. We also impose symmetry under the interchanges $\phi_{u,kl} \leftrightarrow \phi_{v,kl}$. This preserves the $U_{kl} \leftrightarrow V_{lk}$ symmetry ACG needed to avoid large tree-level Higgs boson masses in their model with an $SU(2) \otimes U(1)$ gauge defect at site (1,1) [2]. These symmetries simplify our discussion, e.g., $\phi_{u,kl}$ and $\phi_{v,kl}$ have equal masses and Yukawa couplings. We assume the scalars are heavy, with mass $M_\phi \sim \Lambda$, the strong interaction scale of the fermions.

The Yukawa interactions consistent with gauge and other symmetries are

$$\begin{aligned} \mathcal{L}_Y &= \sum_{k,l=1}^2 [\Gamma_\phi (\bar{\psi}_{L(k,l+1/2)} \phi_{u,kl}^\dagger \psi_{R(k,l+1/2,l)} \\ &\quad + \bar{\psi}_{L(k+1/2,l)} \phi_{v,kl}^\dagger \psi_{R(k+1/2,l)}) + \text{H.c.}]. \end{aligned} \quad (34)$$

We assume $\Gamma_\phi = \Gamma_\phi^* = O(1)$. In the neglect of the weak $SU(m)$ gauge interactions, this theory is still invariant under $[\text{SU}(m)_L \otimes \text{SU}(m)_R]^{2N^2}$ with the symmetry extended to include the scalars.

When the strong $SU(n)$ interactions generate fermion condensates, the Yukawa interactions induce a vacuum expectation value for the scalars:

$$\begin{aligned} \sqrt{2} v_\phi &\equiv \langle \text{Re}(\phi_{u,kl}^0) \rangle = \langle \text{Re}(\phi_{v,kl}^0) \rangle \\ &= \frac{\Gamma_\phi}{M_\phi} \langle \bar{\psi}_{L(k,l+1/2)} \psi_{R(k,l+1/2,l)} \rangle \sim f. \end{aligned} \quad (35)$$

The chiral symmetry is again spontaneously broken to the diagonal $[\text{SU}(m)_V]^{2N^2}$, and the Goldstone bosons are

⁴Cohen and Georgi separately mentioned to me that scalars can induce large plaquette interactions. The implementation used here was suggested to me by Chivukula. It is similar in spirit to Simmons' model in which the gauge bosons of extended technicolor are replaced by scalars [11]. Elementary scalars by themselves make the model unnatural, so the original motivation of a naturally light composite Higgs boson is lost. I assume this can be fixed by supersymmetry.

$$\Pi_{u,v,kl}^a = \frac{f \pi_{u,v,kl}^a + v_\phi \text{Im}(\phi_{u,v,kl}^a)}{\sqrt{f^2 + v_\phi^2}}. \quad (36)$$

Now, $U_{kl} = \exp(i\Pi_{u,kl}/F)$ and $V_{kl} = \exp(i\Pi_{v,kl}/F)$, where $F = \sqrt{f^2 + v_\phi^2}$. The absorbed and physical Goldstone bosons are the same combinations as in Eqs. (20) and (21). If the $\phi_{u,v}$ have strong self-interactions, then so do the PGBs, both directly through the ϕ^4 terms and through the plaquette interactions they induce. The price for this will be large PGB masses.

To generate $\text{Tr}(U_{kl}V_{k,l+1}U_{k+1,l}^\dagger V_{kl}^\dagger)$ and the squared commutator expected from dimensional deconstruction, we suppose there exists the $\text{SU}(m)_{kl}$ gauge-invariant Hamiltonian

$$\mathcal{H}_{\phi 1} = \rho_1 \sum_{k,l} \text{Tr}(\phi_{u,kl} \phi_{v,k,l+1} \phi_{u,k+1,l}^\dagger \phi_{v,kl}^\dagger) + \text{H.c.} \quad (37)$$

This produces quartic PGB interactions and, because there now need be no reflection symmetry to forbid it, it produces \mathcal{H}_\square in Eq. (14) with equal strengths $\lambda_{kl} \sim \rho_1$. Deconstruction does not fix the magnitude of ρ_1 , so we can take it to be anything we want. In particular, we can choose $\rho_1 = O(g^2)$ to make deconstruction's prediction come true. If that gives a Higgs VEV too much larger than its mass, we can just as well choose $\rho_1 = O(1)$.

In the $N=2$ model, however, there is more. There can be interactions that induce the other plaquettes in \mathcal{H}_4 , but linearized,

$$\begin{aligned} \mathcal{H}_{\phi 2} &= \rho_2 \sum_{k,l} [\text{Tr}(\phi_{u,kl} \phi_{v,k,l+1} \phi_{u,k+1,l+1} \phi_{v,kl}^\dagger) \\ &\quad + \text{Tr}(\phi_{u,kl} \phi_{v,k,l+1} \phi_{u,k+1,l}^\dagger \phi_{v,k+1,l})] + \text{H.c.}, \\ \mathcal{H}_{\phi 3} &= \frac{1}{2} \rho_3 \sum_{k,l} \text{Tr}(\phi_{u,kl} \phi_{v,k,l+1} \phi_{u,k+1,l+1} \phi_{v,k+1,l}) \\ &\quad + \text{H.c.}, \quad (38) \\ \mathcal{H}_{\phi 4} &= \frac{1}{2} \rho_4 \sum_{k,l} \text{Tr}(\phi_{u,kl} \phi_{v,k+1,l+1} \phi_{u,k+1,l+1} \phi_{v,kl}^\dagger) \\ &\quad + \text{H.c.} \end{aligned}$$

There can also be ‘‘Wilson-loop’’ interactions that induce the terms in \mathcal{H}_2 and more,⁵

$$\mathcal{H}_{\phi 5} = \rho_5 \sum_{k,l} [|\text{Tr}(\phi_{u,kl} \phi_{u,k,l+1})|^2 + |\text{Tr}(\phi_{v,kl} \phi_{v,k+1,l})|^2], \quad (39)$$

$$\begin{aligned} \mathcal{H}_{\phi 6} &= \sum_{k,l,m,n} [\rho_6 \text{Tr}(\phi_{u,kl} \phi_{u,k,l+1}) \\ &\quad \times \text{Tr}(\phi_{v,mn}^\dagger \phi_{v,m+1,n}^\dagger) + \dots] + \text{H.c.} \end{aligned}$$

⁵Quadratic Wilson-loop interactions can be forbidden by discrete symmetries of the type discussed below.

Dimensional deconstruction does not fix the strengths of these interactions either, but without a symmetry to prevent them there is no reason for them to be much smaller than ρ_1 .

However, if all these ϕ^4 and plaquette interactions are present, they give large $O(\rho_i F^2)$ squared masses to all the PGBs. What symmetries can we invoke to prevent them? Any new symmetry must respect the $\phi_{u,kl} \leftrightarrow \phi_{v,lk}$ interchange. The discrete phase transformations

$$\phi_{u,v,kl} \rightarrow \eta_{u,v,kl} \phi_{u,v,kl}, \quad (40)$$

$$\eta_{u,kl} = \eta_{v,kl}, \quad |\eta_{u,v,kl}| = 1,$$

can forbid all the ϕ^4 interactions, including $\mathcal{H}_{\phi 1}$, *except* $\mathcal{H}_{\phi 4}$ and $\mathcal{H}_{\phi 5}$. Still, these two and the effective interactions they induce are sufficient to generate large M^2 terms for all the PGBs. This illustrates what seems to be a general rule: If the PGBs have strong self-interactions, then there is large explicit symmetry breaking and large PGB masses. If the masses are kept small, then the self-interactions are weak. In either case, the Higgs VEV is always large, $O(\Lambda)$.

Finally, we might well ask why we needed the fermions $\psi_{L,R}$ in this UV completion. Their only useful purpose was to induce the VEV v_ϕ for the scalars. Presumably this could have been accomplished by a negative M_ϕ^2 .

VI. CONCLUSIONS

We conclude that, for the $N=2$ toroidal moose model at least, dimensional deconstruction is not a reliable guide to building a model of naturally light composite Higgs bosons. Deconstruction says the model has two light Higgs multiplets, π_u and π_v , one of which can be given a negative mass-squared and VEV much less than the compositeness scale Λ by putting an $\text{SU}(2) \otimes \text{U}(1)$ gauge defect at one site. We studied whether a small mass and VEV can be obtained with two straightforward UV completions of the model. For the QCD-like completion, we ended up with a model containing five light PGB multiplets and weak self-interactions so that any VEV is of order Λ . For the model which adds strongly interacting scalars, the five PGBs have masses and quartic couplings of $O(g)$ to $O(1)$, but any VEV is still $O(\Lambda)$. We could choose ρ_1 large and all other scalar couplings small, but this is arbitrary, having nothing to do with deconstruction. Furthermore, since this model presumably requires supersymmetry to stabilize it, it does not seem much of an advance beyond earlier supersymmetric or technicolor models.

Finally, what about models with $N \geq 3$? With a QCD-like UV completion, all the PGBs have roughly the same $M^2 = O(g^4 \Lambda^2)$ and $O(g^4)$ quartic couplings. Adding scalars with a strong interaction $\mathcal{H}_{\phi 1}$ can induce \mathcal{H}_\square , raising the mass of all PGBs except π_u and π_v and giving a rather large $\text{Tr}([\pi_u, \pi_v])^2$ coupling. The phase-invariant interaction $\mathcal{H}_{\phi 5}$

has dimension $2N$. If we include it, its strength is naturally ρ_5/Λ^{2N-4} with $\rho_5 \sim 1$. It induces the squared Wilson-loop interaction $\sum_k [|\text{Tr}(U_{k1} \cdots U_{kN})|^2 + |\text{Tr}(V_{1k} \cdots V_{Nk})|^2]$ with strength $\rho_5 F^4 (F/\Lambda)^{2N-4}$ and $M_{\pi_{u,v}}^2 \sim \rho_5 F^2 (F/\Lambda)^{2N-4}$. Again, any Higgs VEV is $v \sim \Lambda$. If we exclude \mathcal{H}_{ϕ_5} , the squared Wilson-loop terms are generated with strength $O(g^4)$ by the weak $SU(m)$ interactions. This, finally, gives a Higgs spectrum and couplings in accord with deconstruction. Supersymmetry at the scale Λ is still needed to keep everything stabilized.

ACKNOWLEDGMENTS

I am especially indebted to Bill Bardeen, Sekhar Chivukula, and Estia Eichten for many discussions and suggestions. I have also benefitted greatly from conversations with Nima Arkani-Hamed, Andy Cohen, Howard Georgi, and Chris Hill. I am grateful to Fermilab and its Theory Group for financial support for this research. It was also supported in part by the U.S. Department of Energy under Grant No. DE-FG02-91ER40676.

-
- [1] N. Arkani-Hamed, A. G. Cohen, and H. Georgi, Phys. Rev. Lett. **86**, 4757 (2001).
 [2] N. Arkani-Hamed, A. G. Cohen, and H. Georgi, Phys. Lett. B **513**, 232 (2001).
 [3] C. T. Hill, S. Pokorski, and J. Wang, Phys. Rev. D **64**, 105005 (2001).
 [4] H. C. Cheng, C. T. Hill, S. Pokorski, and J. Wang, Phys. Rev. D **64**, 065007 (2001).
 [5] H. C. Cheng, C. T. Hill, and J. Wang, Phys. Rev. D **64**, 095003 (2001).
 [6] D. B. Kaplan and H. Georgi, Phys. Lett. **136B**, 183 (1984); S. Dimopoulos *et al.*, *ibid.* **136B**, 187 (1984).
 [7] R. F. Dashen, Phys. Rev. D **3**, 1879 (1971).
 [8] A. G. Cohen, seminar at Aspen Center for Physics, 2001; N. Arkani-Hamed, seminar at Boston University, 2001.
 [9] T. Das *et al.*, Phys. Rev. Lett. **18**, 759 (1967); for this $N=2$ case, see E. Eichten and K. Lane, Phys. Lett. **90B**, 125 (1980); K. Lane, Phys. Scr. **23**, 1005 (1981).
 [10] S. Weinberg, Phys. Rev. Lett. **18**, 507 (1967); C. Bernard, A. Duncan, J. Lo Secco, and S. Weinberg, Phys. Rev. D **12**, 792 (1975).
 [11] E. H. Simmons, Nucl. Phys. **B312**, 253 (1989).