

Analogue models for T and CPT violation in neutral-meson oscillations

V. Alan Kostelecký and Ágnes Roberts

Physics Department, Indiana University, Bloomington, Indiana 47405

(Received 29 December 2000; published 30 March 2001)

Analogue models for CP violation in neutral-meson systems are studied in a general framework. No-go results are obtained for models in classical mechanics that are nondissipative or that involve one-dimensional oscillators. A complete emulation is shown to be possible for a two-dimensional oscillator with rheonomic constraints, and an explicit example with spontaneous T and CPT violation is presented. The results have implications for analogue models with electrical circuits.

DOI: 10.1103/PhysRevD.63.096002

PACS number(s): 11.30.Er, 11.30.Cp, 11.30.Qc, 14.40.Aq

I. INTRODUCTION

Many quantum systems display oscillatory behavior. Among the most interesting are the neutral mesons, where oscillations between particles and antiparticles can violate the product CP of charge conjugation (C) and parity (P) symmetries. In the K system, a small CP violation is experimentally seen [1]. It is associated with breaking of time-reversal symmetry T , with the product CPT being preserved [2]. In fact, a complete formulation of CP -violating oscillations in the K system allows also CPT violation with T being preserved [3,4]. A similar formulation can be developed for any of the neutral mesons K , D , B_d , and B_s [5]. This more general situation is of interest, for example, in the context of possible experimental signals from string theory [6].

Acquiring physical insight into the behavior of meson oscillations in the presence of T and CPT violation is worthwhile. One approach is to construct a simple analogue model in classical mechanics that displays the key features of meson oscillations. *A priori*, it seems most natural to adopt an intuitive picture based on an analogue model in which the meson and its antimeson are represented by two one-dimensional oscillators interacting through some weak coupling. Indeed, basic features of the CP -preserving physics can correctly be modeled in this way [7]. However, modeling T violation is more subtle [8,9].

In this work, we investigate the issue of emulating both T and CPT violation in neutral-meson systems via models in classical mechanics involving small oscillations. We obtain several no-go results, showing that complete emulation of the effective Hamiltonian describing the time evolution of a neutral meson is impossible using models with no damping or using models involving two one-dimensional oscillators with a large class of couplings. This confirms and extends earlier results of Rosner [8]. In contrast, models involving two-dimensional oscillations with appropriate constraints can display effects emulating both T and CPT violation simultaneously. We give an explicit example in which the violation arises spontaneously.

In the next section, we present a few basic results needed for the subsequent analysis. Section III discusses some no-go results. The issue of spontaneous symmetry breaking is considered in Sec. IV. The general analysis leading to a complete emulation of neutral-meson effective hamiltonians, including an explicit model, is given in Sec. V. Section VI

summarizes the results and discusses some open issues, including the implications of our results for the challenge of emulating CP violation with electric circuits.

II. BASICS

In this section, we introduce some basic results needed for the analysis in later sections. Following a discussion of relevant features of the neutral-meson systems, a few considerations appropriate for classical analogue models are presented.

The four relevant neutral-meson systems are K^0 , D^0 , B_d^0 , and B_s^0 . In what follows, we denote by P^0 the strong-interaction eigenstate associated with any one of these. A general neutral-meson state is a linear combination of meson and antimeson wave functions. It can be represented as a two-component object Ψ , with time evolution determined by a 2×2 effective Hamiltonian Λ according to $i\partial_t\Psi = \Lambda\Psi$. The eigenvectors P_S and P_L of Λ are the physical propagating states. The Hamiltonian Λ is composed of a Hermitian mass matrix M and a Hermitian decay matrix Γ : $\Lambda = M - \frac{1}{2}i\Gamma$. Flavor oscillations and T violation are governed by the off-diagonal elements of Λ , while CPT violation is controlled by the difference between its diagonal elements.

A widely used parametrization of Λ is [3]

$$\Lambda = \begin{pmatrix} -iD + E_3 & E_1 - iE_2 \\ E_1 + iE_2 & -iD - E_3 \end{pmatrix}, \quad (1)$$

where D , E_1 , E_2 , E_3 are complex. In this parametrization, T violation occurs when $(E_1E_2^* - E_1^*E_2) \neq 0$ while CPT violation occurs when $E_3 \neq 0$. In terms of real and imaginary components, T violation occurs when

$$(\text{Re } E_2 \text{Im } E_1 - \text{Re } E_1 \text{Im } E_2) \neq 0, \quad (2)$$

and CPT violation when either or both of

$$\text{Re } E_3 \neq 0, \quad \text{Im } E_3 \neq 0 \quad (3)$$

is satisfied. There are therefore three independent real quantities determining CP violation in neutral-meson systems.

The basic goal in achieving the construction of a suitable analogue model is to obtain an oscillating system in classical mechanics with a characteristic matrix reproducing the features of the effective Hamiltonian Λ . It is therefore useful to

consider the extent to which the form (1) of Λ can be modified without affecting the underlying meson physics.

One flexibility in the form of Λ arises because the P^0 and \bar{P}^0 wave functions are eigenstates of the strong interactions, which preserve strangeness, charm, and beauty. For a given system, the phases of the two wave functions can be rotated by equal and opposite amounts without observable consequences. This rotation induces a corresponding change in the phase of the off-diagonal components of Λ , which acts to mix E_1 and E_2 but preserves the combination $(E_1 E_2^* - E_1^* E_2)$ measuring T violation. It follows that a satisfactory analogue model needs to contain features corresponding to this phase-independent measure of T violation. Note, however, that the phase rotation cannot mix components of the mass matrix M with components of the decay matrix Γ .

Another flexibility relevant to the construction of an analogue model is the choice of basis for the meson system. The effective Hamiltonian Λ in Eq. (1) is given in the P^0 - \bar{P}^0 basis. However, other unitarily equivalent bases can also be chosen. A basis transformation by a unitary matrix U converts the state Ψ into $\Psi' = U\Psi$ and results in an effective Hamiltonian $\Lambda' = U^\dagger \Lambda U$. Appropriate choices for U can modify the location of the parameters for T and CPT violation in the effective Hamiltonian, which may have some advantages in matching to an analogue model. Note that, like the phase-rotation freedom, the transformation by U cannot mix components of the mass matrix M with components of the decay matrix Γ .

As an example, consider a CP -eigenstate basis P_1, P_2 obtained from P^0, \bar{P}^0 via the unitary transformation

$$U = \frac{1}{\sqrt{2}} \begin{pmatrix} 1 & 1 \\ 1 & -1 \end{pmatrix}. \quad (4)$$

In the new basis, the effective Hamiltonian $\tilde{\Lambda}$ becomes

$$\tilde{\Lambda} = \begin{pmatrix} -iD + E_1 & E_3 + iE_2 \\ E_3 - iE_2 & -iD - E_1 \end{pmatrix}. \quad (5)$$

The elements of $\tilde{\Lambda}$ are similar to those of Λ , except that E_1 and E_3 have been interchanged. This conversion to $\tilde{\Lambda}$ was used by Rosner and Slezak [9] to show that a modified damped Foucault pendulum can be identified as an analogue model for T violation in the CP -eigenstate basis of a meson system.

Other choices can be made. For example, combining the choice of CP -eigenstate basis with a phase rotation by $\exp(i\pi/4)$ of the P^0 wave function and an opposite rotation of the \bar{P}^0 wave function yields an effective Hamiltonian $\hat{\Lambda}$ given by

$$\hat{\Lambda} = \begin{pmatrix} -iD + E_2 & E_3 - iE_1 \\ E_3 + iE_1 & -iD - E_2 \end{pmatrix}. \quad (6)$$

This corresponds to a modification of Λ involving a cyclic permutation of the three parameters: $(E_1, E_2, E_3) \rightarrow (E_3, E_1, E_2)$.

In developing an analogue model, we adopt the notion that the behavior of the strong-interaction eigenstates P^0, \bar{P}^0 can be modeled classically by identifying them with harmonic oscillators in two generalized coordinates. The energies of the meson eigenstates are emulated by the oscillator frequencies, while the meson decay rates are paralleled by the oscillator dampings.

Since the strong interactions preserve CPT , in the absence of CP violation the two frequencies and decay rates are expected to be equal. The idea is to model the presence of CP violation by introducing appropriate couplings between the two classical oscillators. Following ideas concerning CPT violation in the context of conventional quantum field theory [5,10], we regard it as desirable to obtain CPT violation spontaneously in an analogue model. In fact, we show below that it is also possible to generate T violation spontaneously.

We limit attention to classical models involving small oscillations about equilibrium with linear equations of motion. Assuming harmonic behavior, the linear generalized coordinates q_1, q_2 can be combined in two-component form as $Q = \text{Re}[A \exp(i\omega t)]$, where A is a complex two-component object. The equations of motion can then be expressed by the action of a 2×2 matrix $X(\omega)$ on A , as $XA = 0$. The matrix X is the characteristic matrix of the classical oscillator.

A suitable analogue model for a neutral-meson system is one for which the characteristic matrix X reproduces the features of the meson effective Hamiltonian. In comparisons between the analogue model and the meson system, it is useful to adopt a form for X analogous to that for Λ in Eq. (1). We therefore introduce the parametrization

$$X = \begin{pmatrix} -iA + B_3 & B_1 - iB_2 \\ B_1 + iB_2 & -iA - B_3 \end{pmatrix}, \quad (7)$$

where A, B_1, B_2, B_3 are complex.

The reader is cautioned that, despite the similarity of the parametrizations (1) and (7), the detailed physical meanings of Λ and X differ. For instance, Λ involves a first-order time development while X involves a second-order one. A related point is that the meson state Ψ is intrinsically complex, with physical observables being related to the norm of the probability amplitude. In contrast, the mechanical coordinate Q is real, and the corresponding amplitude A is complex only as a convenient artifact. For example, opposite phase rotations between the two coordinates could produce a physically inequivalent result in the classical analogue model, whereas similar phase rotations on the strong-interaction eigenstates have no physical effect in the meson system.

III. MODELS WITHOUT DAMPING

The intrinsic physical differences between the quantum system and the classical model might seem sufficiently severe to exclude emulation of subtle effects such as T and CPT violation. Indeed, several no-go results can be obtained concerning the existence of an acceptable analogue model for Λ under various circumstances. In this section, we discuss obstacles to the development of an analogue model in

the absence of damping forces. The effects of dissipation are considered in Sec. V.

Consider first a Lagrangian L describing small linear oscillations in a conservative classical-mechanical system. For present purposes, we restrict attention to a system with two degrees of freedom, although some of our formalism and results apply more generally.

Linearity implies that L is quadratic in the real generalized coordinates $Q(t)$ and the first time derivatives $\dot{Q} \equiv dQ/dt$. It can be written as

$$L = \frac{1}{2} \dot{Q}^T T \dot{Q} + \frac{1}{2} \dot{Q}^T G Q - \frac{1}{2} Q^T V Q, \quad (8)$$

where T , G , and V are square matrices of the same dimension as Q . By inspection, T and V are symmetric, while G is antisymmetric. Since L is real, all three matrices can be taken real without loss of generality. We call T , G , and V the kinetic, gyroscopic, and potential matrices, respectively. Note that G violates classical time-reversal symmetry.

The Euler-Lagrange equations of motion obtained from the Lagrangian L are

$$T\ddot{Q} + G\dot{Q} + VQ = 0. \quad (9)$$

The gyroscopic matrix G does *not* represent damping, despite its association with \dot{Q} , because it is derived from a Lagrangian and the corresponding generalized force is conservative. For harmonic solutions with $Q = \text{Re}[A \exp(i\omega t)]$, Eq. (9) becomes $XA = 0$, where the characteristic matrix X has the form

$$X = -\omega^2 T + i\omega G + V. \quad (10)$$

This matrix is Hermitian and so can be diagonalized with real eigenvalues. The normal-mode frequencies are obtained from the condition $\det X(\omega) = 0$, which is a quadratic equation in ω^2 . The absence of damping physically implies that there are two real normal-mode frequencies, and this can be confirmed by inspection of the discriminant of the general solution for ω^2 .

In terms of the parametrization (7) of X , we find

$$\begin{aligned} \text{Re } A &= \text{Im } B_1 = \text{Im } B_2 = \text{Im } B_3 = 0, \\ \text{Im } A &= -\frac{1}{2} \omega^2 (T_{11} + T_{22}) + \frac{1}{2} (V_{11} + V_{22}), \\ \text{Re } B_3 &= \frac{1}{2} \omega^2 (T_{11} - T_{22}) + \frac{1}{2} (V_{11} - V_{22}), \\ \text{Re } B_1 &= -\omega^2 T_{12} + V_{12}, \\ \text{Re } B_2 &= -\omega G_{12}. \end{aligned} \quad (11)$$

The form of Eq. (11) permits several conclusions about the feasibility of constructing nondissipative analogue models for CP violation in neutral-meson systems. Next, we discuss these conclusions for T and CPT violation in turn.

To begin, observe that Eq. (11) includes the result $\text{Im } B_1 = \text{Im } B_2 = 0$ for all possible conservative classical systems. In contrast, Eq. (2) implies that at least one of $\text{Im } E_1$ and $\text{Im } E_2$ must be nonzero for T violation in a meson system. It follows by comparison of Eqs. (1) and (7) that T violation in the P^0 - \bar{P}^0 basis with the effective Hamiltonian Λ cannot be emulated by any nondissipative classical model with two degrees of freedom.

Transformation to some other basis for the meson wave functions offers more flexibility but remains insufficient. For example, in the CP -eigenstate basis a nonvanishing component $\text{Re } E_1$ in the effective Hamiltonian (5) can be modeled with $\text{Re } B_3$, but no means to model $\text{Im } E_1$, $\text{Im } E_2$, $\text{Im } E_3$ exists. The point is that neither the phase-rotation flexibility nor the choice of wave-function basis can mix contributions to the mass matrix M with those to the decay matrix Γ , as discussed in the previous section. Since $\text{Im } E_1$, $\text{Im } E_2$, $\text{Im } E_3$ are contained in Γ while $\text{Re } E_1$, $\text{Re } E_2$, $\text{Re } E_3$ are contained in M , there is no means to convert one type of contribution to another.

We conclude that *it is impossible to emulate T violation in a neutral-meson system with any nondissipative classical model having two degrees of freedom*. In essence, a successful analogue model for T violation in a meson system must involve dissipation because T violation in the meson system itself intrinsically involves dissipative oscillations.

The situation for CPT violation has both similarities and differences. Comparison of Eqs. (1) and (7) shows that nonzero CPT violation in a meson system involving $\text{Re } E_3$ can be emulated by a classical oscillator model for which $\text{Re } B_3 \neq 0$. The result (11) reveals that it suffices to have a difference between the diagonal elements of either the kinetic or the potential matrix. This is straightforward to achieve in a physical system. In contrast, an argument similar to that for T violation demonstrates that *it is impossible to emulate CPT violation involving $\text{Im } E_3$ in a meson system with any nondissipative classical model having two degrees of freedom*. This can again be traced to the association of $\text{Im } E_3$ with the decay matrix Γ and hence with dissipation in the meson system.

The strength of these no-go results suffices to show the need for dissipative classical oscillations. However, before turning to issues pertaining to spontaneous breaking and dissipation, we present some remarks about gyroscopic terms in the context of conservative systems.

For a completely general emulation of neutral-meson systems, we deem it desirable to construct an analogue model for which all eight real parameters in Eq. (7) are nonzero. The result (11) shows that in the absence of damping a nonzero gyroscopic matrix G is needed to obtain a nontrivial $\text{Re } B_2$. In fact, this also holds in the presence of dissipation, as is shown in Sec. V. Models without gyroscopic terms are therefore of lesser interest. However, gyroscopic terms appear in only a restricted class of models. In particular, there is no simple means of generating a nonzero G in models involving two coupled one-dimensional oscillators, as we discuss next.

Prior to linearization, a general Lagrangian describing two coupled one-dimensional oscillators involves a kinetic term for each oscillator and an interaction potential. No gyroscopic term is present. By definition, the kinetic energy of a one-dimensional oscillator involves only one generalized coordinate, so linearization of the kinetic pieces cannot generate the cross-coupling needed for a nonzero G . The potential term would therefore need to be the source of G . However, the gyroscopic term is linear in the generalized velocity, so any appropriate potential term must be velocity dependent. This leaves only a restricted class of possibilities.

It can be shown that G makes no contribution to the Hamiltonian, so any acceptable velocity-dependent potential must describe forces that do no work. Forces that do no work and are described by a velocity-dependent potential certainly exist. A standard example is the Lorentz force on a charged particle moving in a magnetic field. One might, for example, consider a model involving two charged magnetic dipoles, each restricted to move along a one-dimensional curve so that the only possible oscillations are indeed one-dimensional. The force $\vec{F}_{21} \propto \vec{v}_1 \times \vec{B}_2$ on one dipole is determined by its velocity \vec{v}_1 and by the field \vec{B}_2 of the other dipole, as needed. However, this fails to generate directly a nonzero G because $\vec{F}_{21} \cdot \vec{v}_1 = 0$, so the force is orthogonal to the oscillation.

In short, we find that *it is difficult and perhaps impossible to emulate all eight parameters for a neutral-meson effective Hamiltonian with any classical model involving two coupled one-dimensional oscillators*. We conjecture that an impossibility proof could be constructed on the basis that G violates classical time-reversal invariance, which imposes severe constraints on one-dimensional systems. In any event, it would be interesting to obtain an impossibility proof or to provide a simple counterexample.

The above result provides strong motivation to turn instead to an analogue model involving one two-dimensional oscillator. In this case, it is possible to generate a nonzero G under suitable circumstances.

Before linearization, the kinetic term of a two-dimensional model typically involves both generalized coordinates. If the equilibrium coordinates and configuration are independent of time (scleronomic constraints) and if there are no ignorable coordinates, then the kinetic term is quadratic in generalized velocities [11] and so no gyroscopic term emerges upon linearization. However, for the special class of models with time-dependent (rheonomic) constraints, linearization of the kinetic term can generate a nonzero G matrix. For example, suppose the model involves small oscillations about a uniform motion, characterized by a constant v_0 with dimensions of velocity. Then, linearization of the terms quadratic in generalized velocities can lead to expressions involving the product of v_0 and the oscillation velocity \dot{Q} . These are linear in \dot{Q} and under suitable circumstances can yield a nonzero G . Indeed, the term ‘‘gyroscopic’’ refers to the appearance of a nonzero G matrix in the description of small oscillations of uniformly rotating bodies. Note that the classical T violation necessary for gyroscopic terms emerges here as a result of the uniform motion.

IV. SPONTANEOUS SYMMETRY BREAKING

In this section, we discuss the issue of generating T and CPT violation spontaneously in the classical model. The idea is to seek an analogue model with an initial configuration displaying no T or CPT violation, but with a perturbative instability causing a natural dynamical evolution to a stable configuration in which small oscillations violate both T and CPT . This parallels the mechanism for spontaneous breaking of CPT in string field theory [6]. Following the discussion in the previous section, we primarily restrict attention to the case of one two-dimensional oscillator without appreciable dissipation. The situation for viscous damping is considered in the next section.

Consider first a particle moving under the influence of gravity on the interior of a spherical bowl that rotates with constant angular speed Ω about the vertical axis. The configuration with the particle initially at the bottom of the bowl is a solution to the equations of motion. However, an otherwise negligible friction between the particle and the bowl makes this configuration perturbatively unstable if $\Omega^2 > g/a$, where g is the gravitational acceleration and a is the bowl radius. The position of stable equilibrium lies instead on the surface at a vertical distance g/Ω^2 below the center of the bowl. This example, introduced by Lamb in his paper on kinetic stability in 1908 [12], provides a classical implementation of spontaneous breaking of rotational symmetry.

By itself, this example is unsatisfactory as the basis for an analogue model for CP violation in neutral-meson systems because no restoring force is associated with a small horizontal displacement from the equilibrium position on the bowl’s surface. However, a more general surface with non-circular horizontal cross section can avoid this difficulty. One might, for example, consider a surface that is a spherical bowl at the bottom but that smoothly deforms into a surface of uniform elliptical cross section as the height increases. In this case only two equilibrium points occur, located on the semi-major axis of the elliptical cross section. In equilibrium, the particle rotates with the bowl. Small oscillations about either equilibrium point are stable in both vertical and horizontal directions.

For an explicit analysis in the case of a suitable general surface, we adopt cylindrical coordinates (ρ, ϕ, z) with origin at the bottom of the bowl. Let the bowl’s surface be determined by the equation $f(\rho, \phi, z) = 0$, where by assumption f satisfies all the necessary convexity and smoothness conditions. Then, the motion on the surface of a particle of mass m under gravity is determined by the Lagrangian

$$L = \frac{1}{2} m [\dot{\rho}^2 + \rho^2 (\dot{\phi} + \Omega)^2 + \dot{z}^2] - mgz + m\lambda f(\rho, \phi, z), \quad (12)$$

where λ is a Lagrange multiplier. See Fig. 1.

For sufficiently large Ω , spontaneous symmetry breaking occurs. The equilibrium point (ρ_0, ϕ_0, z_0) is determined by the equations $f = 0$, $f_\phi = 0$, and $\rho_0 \Omega^2 + g f_\rho / f_z = 0$ evaluated at the equilibrium point, where subscripts on f indicate partial derivatives. Taking ρ and $\rho_0 \phi$ as generalized coordinates

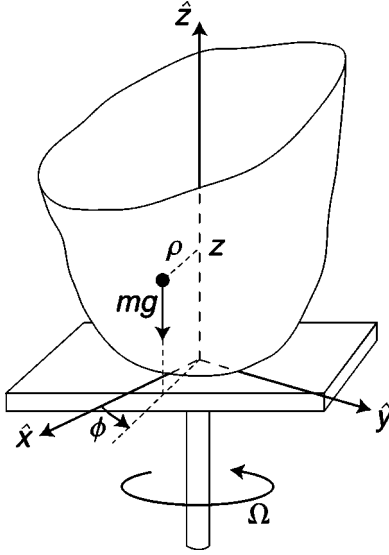

FIG. 1. Particle of mass m moving under gravity on the general surface $f=0$ of a bowl rotating at uniform speed Ω .

for small oscillations of frequency ω about the equilibrium point, a short calculation shows that the characteristic matrix has components

$$\begin{aligned} X_{11} &= -(1 + \Gamma^2)\omega^2 - \Omega^2 - \lambda_0(f_{\rho\rho} + 2\Gamma f_{\rho z} + \Gamma^2 f_{zz}), \\ X_{12} = X_{21}^* &= -2i\Omega\omega - \lambda_0(f_{\rho\phi} + \Gamma f_{\phi z})/\rho_0, \\ X_{22} &= -\omega^2 - \lambda_0 f_{\phi\phi}/\rho_0^2, \end{aligned} \quad (13)$$

where $\Gamma = \rho_0\Omega^2/g$, $\lambda_0 = g/f_z$, and the partial derivatives are again evaluated at the equilibrium point. Note the appearance of the off-diagonal gyroscopic terms $\pm 2i\Omega\omega$, as expected.

For suitable f , this characteristic matrix is sufficiently general to model all four parameters $\text{Im}A$, $\text{Re}B_1$, $\text{Re}B_2$, $\text{Re}B_3$. However, to generate a finite $\text{Re}B_1$ in the absence of dissipation, either $f_{\rho\phi}$ or $f_{\phi z}$ must be nonzero.

A special case, used in the next section, is a bowl with horizontal cross sections near the equilibrium point forming ellipses of constant eccentricity e and semi-major axes with the same orientation. For definiteness, we consider the surface determined near the equilibrium point by

$$f(\rho, \phi, z) = \rho^2(1 - e^2 \cos^2 \phi) - (1 - e^2)(z/k)^{2/n} = 0. \quad (14)$$

This describes a bowl of uniform elliptical horizontal cross section and vertical cross section along the x axis determined by $z = kx^n$. One of the two equilibrium points is at $\rho_0 = (\Omega^2/nkg)^{1/(n-2)}$, $\phi_0 = 0$, $z_0 = k\rho_0^n$. Small oscillations about this point are described in the ρ and $\rho_0\phi$ coordinates by the characteristic matrix

$$X = \begin{pmatrix} -(1 + \Gamma^2)\omega^2 + (n-2)\Omega^2 & -2i\Omega\omega \\ +2i\Omega\omega & -\omega^2 + \epsilon^2\Omega^2 \end{pmatrix}. \quad (15)$$

The component X_{22} involves a function $\epsilon^2(\phi_0)$, defined generally for later purposes as $\epsilon^2(\phi_0) = e^2(2\cos^2\phi_0 - 1)/(1 - e^2\cos^2\phi_0)$. In the present case $\phi_0 = 0$, which gives $\epsilon^2 = e^2/(1 - e^2)$. We note in passing that the oscillatory motions determined by X are stable for $n > 2$.

In this simple model, the term $\text{Re}B_1$ vanishes. The analysis in the next section shows that this can be avoided with the addition of appropriate dissipative terms. However, we note in passing that a nonzero $\text{Re}B_1$ can be obtained without dissipation by a relatively simple modification of the surface, involving a helical twist with height. The idea is to arrange matters so that the semi-major axis of the horizontal elliptical cross section rotates as z increases. It suffices to replace ϕ in the bowl surface function f of Eq. (14) with a function $\phi + \theta(z)$. The equilibrium condition for ϕ becomes $\phi_0 = -\theta(z_0)$, and the characteristic matrix for small oscillations acquires an additional contribution. For example, choosing $\theta(z) = \tau z/\rho_0$ with constant τ produces a characteristic matrix equal to the sum of Eq. (15) and a twist term X_τ , given by

$$X_\tau = \epsilon^2 \tau \Gamma \Omega^2 \begin{pmatrix} \tau \Gamma & 1 \\ 1 & 0 \end{pmatrix}. \quad (16)$$

There is therefore a contribution to $\text{Re}B_1$ determined by the twist constant τ .

V. MODELS WITH VISCOUS DAMPING

In this section, we consider analogue models involving classical oscillators with dissipation. Since we are using linear and homogeneous equations of motion and the corresponding characteristic matrix to model the neutral-meson effective Hamiltonians, we limit attention only to damping forces linear and homogeneous in the generalized coordinates and velocities. We refer to such damping forces as viscous, although this is a somewhat broader definition than normally used by physicists. Note that dry friction can also give linear equations of motion, but typically leads to inhomogeneous terms and so is disregarded here.

The standard procedure in classical mechanics is to obtain viscous damping forces from a Rayleigh dissipation function, which is a symmetric quadratic form in the generalized velocities. However, under special circumstances viscous damping can lead to linear homogeneous damping forces involving also the generalized coordinates [13]. This case is of direct interest in the present context. We therefore work here with a generalized dissipation function \mathcal{F} that can handle damping in a broader class of models [14].

Up to irrelevant terms, we take \mathcal{F} to be a general quadratic expression in the small-oscillation variables Q and \dot{Q} :

$$\mathcal{F} = \frac{1}{2} \dot{Q}^T R \dot{Q} + \dot{Q}^T H Q. \quad (17)$$

As usual, the damping forces are determined by the derivative of \mathcal{F} with respect to the generalized velocities. The real symmetric matrix R contains the standard Rayleigh dissipation matrix for viscous damping, along with any contributions from other types of damping that generate forces linear

in the generalized velocities. The real antisymmetric matrix H determines damping forces linear in the generalized coordinates.

Combined with the Euler-Lagrange equations (9), the generalized dissipation function (17) leads to equations of motion for small oscillations in the classical model given by

$$T\ddot{Q} + (G+R)\dot{Q} + (V+H)Q = 0. \quad (18)$$

A harmonic solution has the form $Q = \text{Re}[A \exp(i\omega t)]$ as before, but in the presence of damping ω is complex. We write $\omega = 2\pi\nu + i\kappa = \mu + i\kappa$. In what follows, we also use $\omega^2 = \Delta^2 + 2i\mu\kappa$, where $\Delta^2 = \mu^2 - \kappa^2$. To simplify the discussion, we take the magnitude of the damping to be sufficiently small that potential complications such as the issue of stability require no special attention.

The characteristic matrix is

$$X = -T\omega^2 + i(G+R)\omega + V + H. \quad (19)$$

In terms of the parametrization in Eq. (7), we find

$$\begin{aligned} \text{Re } A &= \mu\kappa(T_{11} + T_{22}) - \frac{1}{2}\mu(R_{11} + R_{22}), \\ \text{Im } A &= -\frac{1}{2}\Delta^2(T_{11} + T_{22}) - \frac{1}{2}\kappa(R_{11} + R_{22}) \\ &\quad + \frac{1}{2}(V_{11} + V_{22}), \\ \text{Re } B_1 &= -\Delta^2 T_{12} - \kappa R_{12} + V_{12}, \\ \text{Im } B_1 &= -2\mu\kappa T_{12} + \mu R_{12}, \\ \text{Re } B_2 &= -\mu G_{12}, \\ \text{Im } B_2 &= -\kappa G_{12} + H_{12}, \\ \text{Re } B_3 &= -\frac{1}{2}\Delta^2(T_{11} - T_{22}) - \frac{1}{2}\kappa(R_{11} - R_{22}) \\ &\quad + \frac{1}{2}(V_{11} - V_{22}), \\ \text{Im } B_3 &= -\mu\kappa(T_{11} - T_{22}) + \frac{1}{2}\mu(R_{11} - R_{22}). \end{aligned} \quad (20)$$

Inspection of these expressions shows that a sufficiently general model can indeed emulate independently all eight real parameters in the effective Hamiltonian for a neutral-meson system. Note that the parameter $\text{Re } B_2$ is unaffected by dissipation, as mentioned in Sec. III, implying that a complete emulation of the neutral-meson system *requires* a nonzero gyroscopic term and therefore is most readily accomplished using a single two-dimensional oscillator. Note also that the damping force involving the matrix H contributes only to $\text{Im } B_2$, whereas the matrix R affects all parameters other than B_2 .

As an explicit realization of these ideas, we revisit the analogue model considered in Sec. IV describing a particle moving in a uniformly rotating bowl with surface function f . We suppose that the particle experiences an external viscous damping force. This might be implemented with a mesh bowl that allows resistance to the particle motion from the air or from some other static fluid in which the bowl and particle are immersed. We take the generalized dissipation function for this resistance to be

$$\mathcal{F} = \frac{1}{2}mh[\dot{\rho}^2 + \rho^2(\dot{\phi} + \Omega)^2 + \dot{z}^2], \quad (21)$$

where the functional form of $\dot{z} = \dot{z}(\rho, \dot{\rho}, \phi, \dot{\phi})$ is understood to be determined from the bowl surface equation $f=0$. We also suppose that the parameter h , which controls the magnitude of the damping forces, is sufficiently small to avoid difficulties with stability.

Inspection of the forces obtained from Eq. (21) reveals that an additional constant damping force $h\rho_0^2\Omega$ in the ϕ direction acts on the particle at equilibrium and moves the equilibrium position away from the previously determined location. For example, in the special case of a uniform elliptical horizontal cross section, the equilibrium point is displaced from the apex of the ellipse. In general, the location of the new equilibrium point is determined by the simultaneous solution of the three equations $f=0$, $f_\rho + \Gamma f_z = 0$, and $f_\phi - \Sigma\rho_0 f_z = 0$, where $\Sigma = h\Gamma/\Omega$.

The dissipation function \mathcal{F} in Eq. (21) describes the fluid resistance to the particle motion. For small oscillations, it includes both Rayleigh-type dissipation via a matrix R and damping linear in Q described by a matrix H . It thus implements the form of Eq. (17). The associated equations of motion can be derived, along with the accompanying characteristic matrix. We find that the components of the characteristic matrix are the sum of the corresponding components in Eq. (13) with additional terms given by the components of a matrix ΔX :

$$\begin{aligned} \Delta X_{11} &= ih(1 + \Gamma^2)\omega, \\ \Delta X_{12} &= \Gamma\Sigma\omega^2 + \lambda_0\Sigma(f_{\rho z} + \Gamma f_{zz}) - ih\Gamma\Sigma\omega, \\ \Delta X_{21} &= \Delta X_{12} + 2h\Omega, \\ \Delta X_{22} &= -\Sigma^2\omega^2 + 2\lambda_0\Sigma f_{\phi z}/\rho_0 - \lambda_0\Sigma^2 f_{zz} \\ &\quad + ih(1 + \Sigma^2)\omega. \end{aligned} \quad (22)$$

This result shows that the introduction of a relatively simple viscous damping force suffices to ensure that all four parameters $\text{Re } A$, $\text{Im } B_1$, $\text{Im } B_2$, $\text{Im } B_3$ can become nonzero.

For the special case of the bowl with uniform elliptical horizontal cross section described by Eq. (14), the incorporation of viscous damping via Eq. (21) results in an equilibrium point at $z_0 = \Omega^2\rho_0^2/ng$, with $\rho_0^2 = [(1 - e^2)^n\Omega^4 / (1 - e^2\cos^2\phi_0)(nkg)^2]^{1/(n-2)}$ and $\tan\phi_0 = -(1 - \sqrt{1-x})/a$, where $x = (1 - e^2)a^2$ and $a = 2h/e^2\Omega$. The reality of ϕ_0 constrains the magnitude of h to $|h| \leq e^2|\Omega|/2\sqrt{1 - e^2}$. The corresponding characteristic matrix for small oscillations in the

ρ and $\rho_0\phi$ coordinates is given by the sum of Eq. (15) with an additional matrix ΔX . In analogy with Eq. (19), ΔX can be taken to have the form

$$\Delta X = -\Delta T\omega^2 + i\Delta R\omega + \Delta V + \Delta H. \quad (23)$$

Note that a putative term of the form ΔG is absent, as expected. The matrices ΔT , ΔR , ΔV , ΔH are

$$\Delta T = \begin{pmatrix} 0 & -\Gamma\Sigma \\ -\Gamma\Sigma & \Sigma^2 \end{pmatrix}, \quad (24)$$

$$\Delta R = \begin{pmatrix} h(1+\Gamma^2) & -h\Gamma\Sigma \\ -h\Gamma\Sigma & h(1+\Sigma^2) \end{pmatrix}, \quad (25)$$

$$\Delta V = \begin{pmatrix} 0 & -(n-1)h\Omega \\ -(n-1)h\Omega & (n-2)h^2 \end{pmatrix}, \quad (26)$$

$$\Delta H = \begin{pmatrix} 0 & -h\Omega \\ h\Omega & 0 \end{pmatrix}. \quad (27)$$

For small h and hence small Σ , the diagonal elements of the matrices ΔT , ΔV can be viewed as perturbations on the result (15), which involves nonzero T , G , and V . However, the contributions from the off-diagonal elements of ΔT , ΔV and from ΔR , ΔH are crucial for the complete emulation of a neutral-meson effective Hamiltonian. In particular, Eq. (20) shows that the parameters $\text{Re}A$, $\text{Im}B_1$, $\text{Im}B_2$, $\text{Im}B_3$ are all nonzero, as desired.

VI. SUMMARY AND DISCUSSION

This paper studied the emulation of indirect CP violation in neutral-meson systems using oscillator models in classical mechanics. We obtained some no-go results for analogue models without damping and for ones involving two one-dimensional oscillators. The implementation of spontaneous symmetry breaking was shown to be feasible. We proved that analogue models involving one two-dimensional oscillator with rheonomic constraints can suffice to emulate all eight real parameters in the meson effective Hamiltonian, including the three describing physical T and CPT violation.

We presented a specific analogue model that provides a complete emulation. It involves a particle moving under gravity on the surface of a uniformly rotating bowl of elliptical cross section in the presence of weak external viscous damping. The equations for small oscillations about an equilibrium point are determined by a characteristic matrix given as the sum of X in Eq. (15) and ΔX in Eq. (23). The parametrization (7) of this characteristic matrix, with parameters fixed by Eq. (20), can be placed in one-to-one correspondence with the parametrization (1) in the P^0 - \bar{P}^0 basis of the effective Hamiltonian Λ for a neutral-meson system. The correspondence is $A \leftrightarrow D$, $B_1 \leftrightarrow E_1$, $B_2 \leftrightarrow E_2$, $B_3 \leftrightarrow E_3$. Correspondences also exist with the effective Hamiltonian (5) in the CP -eigenstate basis or, since the emulation is complete, in any other basis.

The results we have obtained leave open some interesting issues. One is the extent to which quantitative values of experimental observables in any neutral-meson system can be emulated in a realistic version of the models we have discussed. A satisfactory match would require reproducing the relative sizes of the values of the masses, lifetimes, and parameters for CP violation. Since the experimental data available on oscillations in the four neutral-meson systems range from being relatively complete for the K to limited for the B_s , the degree of difficulty in obtaining a satisfactory match varies considerably. In any case, the full flexibility of the analogue models is unnecessary because no CPT violation has been observed to date [15–17]. For the special case of the K system CP violation is observed to be small, so an emulation involving small dissipation is likely to be possible. It would be interesting to determine the feasibility of constructing a quantitatively accurate model, including perhaps constructing a working prototype.

A more ambitious task would be to explore the insights provided by the model about T and possible CPT violation with an eye to understanding its origin in nature and the neutral-meson systems. For example, it is intriguing that the no-go results strongly favor two-dimensional systems with rheonomic constraints. This suggests a preference for a dynamical origin of CP violation. Similarly, it is interesting that the CPT violation in the analogue model emerges from a violation of rotation invariance. This would appear to correspond with the situation in conventional quantum field theory in the context of the standard model, where the known mechanism for CPT violation originates in the spontaneous violation of Lorentz symmetry [18] and implies CPT signals in neutral-meson systems that depend on the orientation and magnitude of the meson momentum [19].

Another interesting topic, raised by Rosner [8], is the emulation of T and CPT violation by electrical circuits. The general analysis we have provided in this work can offer some insights. A detailed analysis of this subject lies beyond the scope of this work, but in what follows we provide a few remarks.

Suppose that each of the strong-interaction eigenstates P^0 and \bar{P}^0 is modeled as an oscillating electric circuit, with CP violation regarded as a weak coupling between them. For definiteness, we view the two meson wave functions as corresponding to the charges $q_1(t)$, $q_2(t)$ flowing through the circuits as a function of time. As in the case of the analogue model in classical mechanics, the energies of the meson eigenstates are emulated by the oscillator frequencies while the meson decay rates correspond to the oscillator dampings. Inductances in the circuit replace masses in the mechanical model, inverse capacitances replace coupling constants in the potential, and resistances provide dissipation.

The two-component meson wave function Ψ can be identified with a two-component object $Q(t)$ formed from q_1 and q_2 , as for the case of a classical-mechanics model. We take the differential equations describing oscillations of the charges in the circuit to be linear in Q and its time derivatives $\dot{Q} = I$ and $\ddot{Q} = \dot{I}$, where I is the two-component current. In the absence of dissipation, the equation governing the os-

cillatory behavior of Q is Eq. (9), where the matrices T , G , V are interpreted as characterizing appropriate properties of the circuit. This means that much of the analysis in Sec. III applies in modified form. In particular, the results obtained there reveal that a primary obstacle to a complete emulation of CP violation via electric circuits is the need for an anti-symmetric matrix G coupling the currents in the two circuits.

A suitable circuit realization of G requires a two-port device that is passive (no energy storage, increase, or dissipation). The antisymmetry implies that reciprocity is broken: a potential \mathcal{V} applied across the first port would induce a current across the second differing in phase by π relative to the current induced across the first port when the same \mathcal{V} is applied across the second. Remarkably, two-port devices of this type, called gyrators, have been the subject of some attention in the specialized electronics literature since their original invention by Tellegen in 1948 [20]. Moreover, a variety of network realizations of a gyrator exist [21].

We therefore suggest it is feasible to develop an electric circuit emulating all eight parameters in the effective Hamiltonian for a neutral-meson system, including both T and CPT violation. A gyrator would implement the crucial T -violating features of Eq. (9) and in particular a nonzero $\text{Re} B_2$ in Eq. (11). As in the case of the classical-mechanics oscillators, it would also be necessary to include dissipation.

This requires designing a circuit that incorporates suitable damping elements leading to the oscillatory behavior given by Eq. (18). A general matrix R can be obtained by a suitable placement of resistors in the circuit, though producing a dissipation matrix of the form of H might be less straightforward. Developing an electrical realization of spontaneous symmetry breaking would also be attractive. A circuit designed to exhibit all these features would make an impressive tabletop demonstration emulating T and CPT violation in neutral-meson systems.

The results obtained in the present work may also have application in the emulation of other quantum oscillations in physics. For example, it would be of interest to study analogue models for neutrino oscillations. A complete analysis for this case is likely to be more involved, partly because three neutrino species are known and the options for CP and CPT violation are correspondingly more complicated. Nonetheless, an explicit analogue model in classical mechanics or with electric circuits could provide valuable insight.

ACKNOWLEDGMENTS

This work was supported in part by the United States Department of Energy under grant number DE-FG02-91ER40661.

-
- [1] J.H. Christenson, J.W. Cronin, V.L. Fitch, and R. Turlay, *Phys. Rev. Lett.* **13**, 138 (1964).
 - [2] For a textbook treatment of the discrete symmetries C , P , T , see, for example, R.G. Sachs, *The Physics of Time Reversal* (University of Chicago Press, Chicago, 1987).
 - [3] See, for example, T.D. Lee, and C.S. Wu, *Annu. Rev. Nucl. Sci.* **16**, 511 (1966).
 - [4] We limit attention in this work to indirect CP violation.
 - [5] V.A. Kostelecký and R. Potting, *Phys. Rev. D* **51**, 3923 (1995).
 - [6] V.A. Kostelecký and R. Potting, *Nucl. Phys.* **B359**, 545 (1991); *Phys. Lett. B* **381**, 89 (1996); *Phys. Rev. D* **63**, 046007 (2001).
 - [7] B. Winstein, in *Festi-Val — Festschrift for Val Telegdi*, edited by K. Winter (Elsevier, Amsterdam, 1988).
 - [8] J.L. Rosner, *Am. J. Phys.* **64**, 982 (1996).
 - [9] J.L. Rosner and S.A. Slezak, *Am. J. Phys.* **69**, 44 (2001).
 - [10] D. Colladay and V.A. Kostelecký, *Phys. Rev. D* **55**, 6760 (1997); **58**, 116002 (1998).
 - [11] See, for example, E.T. Whittaker, *Analytical Dynamics*, 4th ed. (Dover, New York, 1944).
 - [12] H. Lamb, *Proc. R. Soc. London* **A80**, 168 (1908).
 - [13] A variety of examples are given in M. Roseau, *Vibrations in Mechanical Systems* (Springer-Verlag, New York, 1987).
 - [14] For instance, circulatory damping forces arising in cranks and shafts can be described with a generalized dissipation function \mathcal{F} . See, for example, L. Meirovitch, *Principles and Techniques of Vibrations* (Prentice-Hall, Englewood Cliffs, NJ, 1997).
 - [15] For recent experiments bounding CPT violation in the K system, see L.K. Gibbons *et al.*, *Phys. Rev. D* **55**, 6625 (1997); KTeV Collaboration, Y.B. Hsiung *et al.*, in the Proceedings of the 1999 Chicago Conference on Kaon Physics, Chicago, Illinois, 1999, FERMILAB-CONF-99-313-E.
 - [16] No experimental bounds have been published on CPT violation in the D or B_s systems, although some proposals exist. See Ref. [5] and D. Colladay and V.A. Kostelecký, *Phys. Lett. B* **344**, 259 (1995); *Phys. Rev. D* **52**, 6224 (1995); V.A. Kostelecký and R. Van Kooten, *ibid.* **54**, 5585 (1996).
 - [17] Experiments bounding CPT violation in the B system include: OPAL Collaboration, R. Ackerstaff *et al.*, *Z. Phys. C* **76**, 401 (1997); DELPHI Collaboration, M. Feindt *et al.*, DELPHI 97-98 CONF 80, 1997.
 - [18] V.A. Kostelecký and S. Samuel, *Phys. Rev. Lett.* **63**, 224 (1989); *Phys. Rev. D* **39**, 683 (1989); **40**, 1886 (1989).
 - [19] V.A. Kostelecký, *Phys. Rev. Lett.* **80**, 1818 (1998); *Phys. Rev. D* **61**, 016002 (2000).
 - [20] B.D.H. Tellegen, *Philips Res. Rep.* **3**, 81 (1948).
 - [21] See, for example, M.S. Ghauri, *Electronic Circuits* (Van Nostrand Reinhold, New York, 1971).