

Top-quark–charm-quark strong flavor-changing neutral currents at the Fermilab Tevatron

Ehab Malkawi and Tim Tait

Department of Physics and Astronomy, Michigan State University, East Lansing, Michigan 48824

(Received 30 November 1995; revised manuscript received 26 June 1996)

The possibility of an anomalous coupling between the top and charm quarks and the gluon field is explored in a model-independent way using an effective Lagrangian that is gauge invariant under a nonlinear realization of $SU(3)_C \times SU(2)_L \times U(1)_Y$. Even for the current 200 pb^{-1} of integrated luminosity at the Fermilab Tevatron, the new physics scale that strongly modifies the coupling of t - c - g must be larger than about 2.5 TeV if no signal is found within a 3σ confidence limit. For 1 fb^{-1} of data, this constraint can be pushed up to 3.8 TeV. [S0556-2821(96)02321-1]

PACS number(s): 12.15.Mm, 14.65.Dw, 14.65.Ha

I. INTRODUCTION

With the discovery of the top quark at Fermilab by the $D\bar{O}$ and Collider Detector at Fermilab (CDF) Collaborations, it has become natural to study its interactions with the gauge bosons. The standard model (SM) completely predicts how the top quark should behave under these interactions, so any deviation from this behavior would provide us with a probe of new physics beyond the SM.

The top (t) quark is very heavy, about 35 times that of the next heaviest quark, the top's weak partner, the bottom (b). For this reason it is a likely place to search for new physics. If new physics is found in the top quark sector, it is possible that this new physics could explain why the top is so heavy and how its mass is generated. This could in turn provide us with clues as to how the other quark masses arise (a question the SM makes no effort to address).

Perhaps there is new physics specific to the third family, physics which can explain why the top, bottom, and τ lepton are so much heavier than their first- and second-family counterparts. Or there could be new interactions that are not really involved in producing the large masses, but coupling more significantly to particles with large mass, and thus can be detected by studying the top, while only affecting the other quarks insignificantly.

The top quark mass is of the order of the electroweak symmetry breaking (EWSB) scale $v = 246 \text{ GeV}$, and thus provides a probe of the physics associated with the generation of the masses for the weak gauge bosons. The Higgs mechanism of the SM requires a neutral scalar particle (the Higgs boson) which has yet to be directly detected experimentally, but could affect (although marginally) low energy experimental results through loop effects. If the Higgs mechanism with Yukawa interactions is responsible for the generation of the fermion masses, the Higgs boson should have a coupling with the top quark of the order of m_t/v , and thus interactions involving the top quark may provide a probe of the Higgs physics.

The SM does not contain tree-level flavor-changing neutral currents (FCNC's), though they can occur at higher order through radiative corrections. Because of the loop suppression, these SM effects will be small, and so large FCNC's provide a window into physics beyond the SM. In this paper, we are specifically interested in the possibility of a top-

quark–charm-quark–gluon (t - c - g) coupling. As we have explained above, it is natural to look to the top quark as a window to new physics. If this new physics may participate in the generation of fermion masses, it is reasonable to assume that the coupling of the top to the other up-type quarks should be proportional to $\sqrt{m_t m_{c(u)}}$ [1]. This leads to the conclusion that the top-charm coupling is more likely to lead to measurable effects than the top-up coupling. A study similar to ours of the t - c - Z anomalous coupling can be found in [2,3].

There are a number of interesting models [4,5] in the literature that can produce this kind of anomalous coupling, and for this reason it is useful to study this kind of interaction experimentally in order to constrain parameters in these theories. In this paper we study the t - c - g vertex in an effective Lagrangian, model-independent way. We show how it is possible to use single-top production data from the Fermilab Tevatron to constrain the t - c - g coupling.

II. THEORY

To incorporate new physics, we consider an effective Lagrangian

$$\mathcal{L}_{\text{eff}} = \mathcal{L}_0 + \mathcal{L}_1, \quad (1)$$

where \mathcal{L}_1 contains operators of dimension higher than four, multiplied by coefficients with appropriate dimensions of mass to ensure that the dimension of the Lagrangian as a whole remains four. It is including terms of this kind that leads us to call this an ‘‘effective Lagrangian’’; since the resultant theory is not valid to an arbitrarily high energy scale, it is not a fundamental physical theory. Instead, it represents the theory that is ‘‘effective’’ at a lower energy scale where the energy is too low to allow us to see the full details of the underlying physics. The coefficients with dimensions of mass in front of the effective terms characterize the mass scale at which new physics must enter the theory if any non-SM effect is to be found. In our case, since we wish to consider the possibility of a flavor-changing gluonic current, \mathcal{L}_0 will be the QCD Lagrangian,

$$\mathcal{L}_0 = -\frac{1}{4} G_{\mu\nu}^a G^{a\mu\nu} + \bar{q}i \gamma^\mu D_\mu q - m_q \bar{q}q, \quad (2)$$

where $D_\mu = \partial_\mu - ig_s(\lambda^a/2)G_\mu^a$, and $G^{a\mu\nu}$ is the usual gluon field strength tensor.

We are interested in exploring the possibility that the gluon current can couple the top and charm quarks at tree level in an effective theory valid up to a scale of A . \mathcal{L}_1 must be constructed in such a way as to accomplish this, respecting the $SU(3)_C$ gauge invariance of QCD. Our effective theory must contain a cutoff mass scale, A , that is appreciably larger than the energy scale at which we do calculations, for as stated above, it is only in this region that the effective theory is valid. Since any higher dimension operators we introduce will be suppressed by a power of the cutoff mass that fixes the overall dimension of the term at four, we expect that the effective operators of lower dimension should be more important than the higher dimension ones. The lowest dimension effective operator we can add to produce a t - c - g coupling is dimension five. It is given by

$$\mathcal{L}_1 = \frac{g_s \kappa_R}{A} \left(\frac{\lambda^a}{2} G_{\mu\nu}^a \sigma^{\mu\nu} c_L + \text{H. c.} \right) + \frac{g_s \kappa_L}{A} \left(\frac{\lambda^a}{2} G_{\mu\nu}^a \sigma^{\mu\nu} c_R + \text{H. c.} \right), \quad (3)$$

where A represents a mass cutoff scale above which our effective theory breaks down, and $\kappa_{L(R)}$ are dimensionless parameters that relate the strength of the ‘‘new coupling’’ to the strong coupling constant g_s for left- (right-) handed top quarks. If the imaginary part of $\kappa_L \kappa_R^*$ does not equal zero, this interaction will violate CP conservation. For simplicity, we will restrict our study to the case where $\kappa_{L(R)}$ is real, so CP is conserved.

\mathcal{L}_1 is invariant under local $SU(3)_C$ gauge transformations. It is also invariant under a nonlinear realization of the broken symmetry $SU(2)_L \times U(1)_Y \rightarrow U(1)_{EM}$, as in the chiral Lagrangian [6–8]. An example of this is provided in [8] where the $SU(2)_L \times U(1)_Y$ symmetry is realized in such a way that the fermion fields transform as their $U(1)_{EM}$ charges. It is clear that \mathcal{L}_1 is invariant under this realization of $SU(2)_L \times U(1)_Y$ because the top and charm have the same electric charge and the gluon field is an electroweak singlet.

Once the terms in the Lagrangian are specified, one can derive the Feynman rules corresponding to the vertices in the theory. The form of the gluon field strength tensor will produce two different types of vertices (for each $\kappa_{L(R)}$), a four-point coupling of two gluons and the top and charm quarks, and a three-point vertex coupling of one gluon line and the top and charm quarks.

In order to study the t - c - g couplings introduced by \mathcal{L}_1 and to determine the minimum energy scale A that would contribute to these couplings, we consider the production of the top charm at a hadron collider. There are seven tree-level diagrams (for each top quark helicity) that contribute to $t\bar{c}$ production, as shown in Fig. 1. As we will argue below in Sec. III, it is useful to require that the invariant mass $M_{t\bar{c}} \geq 300$ GeV to separate the signal from the background. By energy conservation, this is the same as requiring the invariant mass of the incoming partons $\sqrt{\hat{s}} \geq 300$ GeV. As a result, the $q\bar{q}$ annihilation diagram dominates the diagrams that have gluons as incoming partons. This is because the

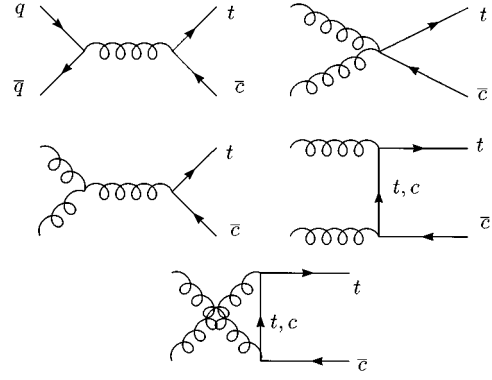

FIG. 1. Feynman diagrams for single-top production via t - c - g vertices.

parton distribution functions¹ are such that for large $\sqrt{\hat{s}}$, most of the momentum is carried by the quarks; the probability of observing a gluon carrying a momentum fraction in the range we are interested in ($x = \sqrt{\hat{s}}/\sqrt{s} \geq 0.15$) is much smaller than that of a quark carrying the same momentum. The gg luminosity is about 0.20 times the $q\bar{q}$ luminosity. Therefore, for $\sqrt{\hat{s}} \geq 300$ GeV, we can approximate the whole process by the single $q\bar{q}$ annihilation diagram.

Considering for the moment just the $t\bar{c}$ production without any decays, we find that the constituent cross section after integrating over the final state phase space is given by

$$\hat{\sigma}(q\bar{q} \rightarrow t\bar{c}) = \frac{g_s^4 (\kappa_L^2 + \kappa_R^2)}{27\pi A^2} \frac{(\hat{s} - m_t^2)^2}{\hat{s}^3} (\hat{s} + 2m_t^2). \quad (4)$$

Note that in the high energy limit (i.e., for large $\sqrt{\hat{s}}$), $\hat{\sigma}$ is a constant and does not have the usual functional form of $1/\hat{s}$. For simplicity, we do not study $\kappa_{L(R)}$ separately in this work; here we are interested in the energy scale at which new physics largely modifies the t - c - g coupling. In the rest of this paper, we restrict ourselves to $\kappa_L = \kappa_R$ (a vectorlike coupling).² This leads us to define

$$\kappa^2 = \kappa_L^2 + \kappa_R^2. \quad (5)$$

The constituent cross section contains κ and A only in the combination κ/A , thus it is convenient to define

$$\Lambda = \frac{A}{\kappa}, \quad (6)$$

so that κ has been absorbed. This leaves us with one parameter to compare with experimental data. For $|\kappa| \sim 1$, Λ is

¹The CTEQ2 leading order fit parton distribution functions are used in all calculations.

²In principle, one could look at the angular distribution of the top quark’s decay products to determine the coefficients κ_L and κ_R for a given A .

about the same as the cutoff scale described above, and characterizes the effective strength of the new couplings.

One could also try to learn the theory's parameters by considering the decay $t \rightarrow cg$, but this is not very well suited to a hadron collider because of potentially large backgrounds from which the signal events cannot easily be distinguished. However, for completeness, we present the decay width $t \rightarrow cg$, in the restframe of the top quark,

$$\Gamma(t \rightarrow cg) = \frac{8\alpha_s m_t^3}{3\Lambda^2}. \quad (7)$$

The dependence on m_t of this result may easily be understood from dimensional arguments. Because the t - c - g coupling contains the factor Λ^{-1} , the width must be proportional to Λ^{-2} . If the charm quark mass is taken to be zero, the only energy scale is m_t and since the width must have the dimension of energy, it must be proportional to m_t^3 . In order to use this information to determine Λ , we find the ratio defined as

$$R_{tcg} = \frac{\Gamma(t \rightarrow cg)}{\Gamma(t \rightarrow W^+ b)}, \quad (8)$$

where

$$\Gamma(t \rightarrow W^+ b) = \frac{G_F m_t^3}{\sqrt{2} 16\pi} \left[1 - \frac{m_W^2}{m_t^2} \right]^2 \left[1 + 2 \frac{m_W^2}{m_t^2} \right] \quad (9)$$

is the decay width $\Gamma(t \rightarrow W^+ b)$ [9]. Combining these two equations to find R_{tcg} , we find

$$R_{tcg} = \frac{\sqrt{2} 64\alpha_s \pi m_t^2}{3\Lambda^2 G_F [1 - m_W^2/m_t^2]^2 [1 + 2(m_W^2/m_t^2)]}. \quad (10)$$

We will discuss the implications of this result in Sec. V.

III. SIGNAL AND BACKGROUND

In this section we discuss the detection efficiency of the signal events at the upgraded Tevatron (a 2 TeV $p\bar{p}$ collider). The top quark decay mode studied is $t \rightarrow bW^+ (\rightarrow \ell^+ \nu)$ for $\ell = e$ or μ .

Including the decay of the top quark, the process $q\bar{q} \rightarrow t\bar{c}$ results in the final state $Wb\bar{c}$. Thus, the signature of this process is an energetic charged lepton, missing E_T , a b -quark jet from the top decay, and a light jet. This signal has (neglecting all of the quark masses except for that of the top) kinematics similar to the standard model process $q\bar{q} \rightarrow W^* \rightarrow t\bar{b}$, which has been studied in [10,11], including the relevant backgrounds. In this study we consider the following intrinsic background processes: $t\bar{q}$ produced by W -gluon fusion, $Wb\bar{b}$, $t\bar{b} \rightarrow Wb\bar{b}$, $t\bar{t} \rightarrow W^- W^+ b\bar{b}$, Wjj . The potentially large background from Wjj can be reduced by requiring a b quark to be present in the final state (i.e., b tagging). The CDF Collaboration has effectively implemented this procedure by using a silicon vertex detector (SVX). For run II, the efficiency is estimated to be 60% per b jet ($p_T^b > 20$ GeV and η_b within the SVX coverage), with a probability of less than 1% for a light quark or gluon jet to be misidentified as a b jet [3]. We require that only a single b

TABLE I. Fundamental kinematic cuts.

$p_T^j > 10$ GeV
$p_T^{\ell} > 20$ GeV
$ \eta_{\ell} \leq 2.5$
$ \eta_j \leq 3.5$
$ \eta_b \leq 2.0$
$\Delta R_{j\ell} \geq 0.4$
$\Delta R_{jj} \geq 0.4$

quark be identified in the final state in order to accept the event, and we have ignored the possibility of a c quark being mistagged as a b quark.

The number of events for the signal and backgrounds mentioned above were calculated for the Tevatron³ (assuming an integrated luminosity $L = 1$ fb⁻¹) using the Monte Carlo program ONETOP [11,12], except for Wjj which was calculated using PAPANENO [13]. The W -gluon fusion rate is calculated from the two-body process, and normalized by the total rate as explained in [11]. The top mass is taken to be $m_t = 175$ GeV and the masses of the lighter quarks are neglected. The signal and background cross sections include the decay $W \rightarrow \ell \nu$ (where $\ell = e, \mu$) and both the W^+ and W^- production modes are included. (Since the dominant W decay modes are hadronic, ignoring the possibility of $W \rightarrow$ hadrons reduces the signal, but the high p_T charged lepton resulting from the leptonic decay modes provides an excellent trigger at a hadron collider.) For now, we choose $\Lambda = 2$ TeV. We will discuss how to determine this parameter from experimental data below.

Table I lists the primary cuts imposed to simulate the detector acceptance. p_T denotes transverse momentum, η denotes the pseudorapidity, and $\Delta R_{j\ell} = \sqrt{\Delta\phi_{j\ell}^2 + \Delta\eta_{j\ell}^2}$, where $\Delta\phi_{j\ell}$ is the difference in the azimuthal angle ϕ between j and ℓ . The $t\bar{c}$ production rate is not very sensitive to the pseudorapidity cuts because the decay of the heavy top quark will generally produce b jets and leptons in the central region. Thus, narrowing the pseudorapidity range should not significantly affect the signal rates, but will reduce the $Wb\bar{b}$ background. Only minimal p_T cuts for the jets are imposed here. In our final analysis these cuts have been chosen specifically to enhance the signal versus the background, and will be explained below. The events remaining after these cuts (not including the 60% b -tagging efficiency) are shown in the second column of Table II.

From the form of the constituent cross section given in Eq. (4), we see that for large \hat{s} , the cross section for $t\bar{c}$ production does not fall off as $1/\hat{s}$ as it will for most of the background processes. This suggests that one way to improve the signal to background ratio is to impose a cut on \hat{s} , which by energy conservation is equivalent to imposing a cut on $M_{t\bar{c}}$. We find that the best result is obtained by requiring $M_{t\bar{c}} \geq 300$ GeV. This presents something of a problem because there is no way to directly measure $M_{t\bar{c}}$. In order to reconstruct $M_{t\bar{c}}$ we can use the lepton momentum and the missing transverse momentum in the equation

³ $\sqrt{s} = 2$ TeV $p\bar{p}$ collider.

TABLE II. Total number of events at the Tevatron, including kinematic cuts, for $L = 1 \text{ fb}^{-1}$ and $\Lambda = 2 \text{ TeV}$. The fundamental cuts denote those in Table I.

Process	Fundamental	$M_{t\bar{c}} \geq 300 \text{ GeV}$	$p_T^b \geq 30 \text{ GeV}$	$p_T^c \geq 30 \text{ GeV}$	b tagging
$t\bar{c}$	308	276	256	256	154
W - g fusion	188	168	152	132	79
$Wb\bar{b}$	168	124	88	72	35
$t\bar{b}$	40	36	28	28	13
$t\bar{t}$	4	4	0	0	0
Wjj				4000	80
Tot. background				4232	207

$$M_W^2 = (p_{\ell} + p_\nu)^2, \quad (11)$$

to find two solutions for the missing component (i.e., the component along the z axis) of p_ν , where p_ν is the neutrino four-momentum. The solution which better fits the decay of an on-shell top quark,

$$M_t^2 = (p_{\ell} + p_\nu + p_b)^2, \quad (12)$$

is chosen.⁴ The other solution is discarded. For the signal, there is only one b jet, so we can do this without any problem. However, for most of the background processes, there is more than one b jet, and it is impossible to know *a priori* which one should be associated with the top decay. To handle this, we randomly decide which b jet to use for those processes which contain more than one b jet in the final state. In order to allow for an off-shell W , we iterate this procedure three times, generating a different Breit-Wigner mass for the W each time, and keep the first result in which a solution exists. Once we have determined the four-momenta p_ν , p_{ℓ} , and p_c , it is simple to use energy conservation to reconstruct the invariant mass $M_{t\bar{c}}$. We impose the cut $M_{t\bar{c}} \geq 300 \text{ GeV}$ on the signal and backgrounds, and the results are displayed in the third column of Table II.

The $t\bar{t}$ background is reduced by rejecting events that contain evidence of the decay of an additional W boson. Specifically, events containing an additional lepton with $p_T^{\ell} \geq 20 \text{ GeV}$ and $|\eta_{\ell}| \leq 2.5$, or additional distinguishable jets with $p_T^j > 20 \text{ GeV}$ and $|\eta_j| \leq 3.5$ are rejected (two parton jets are considered distinguishable if $\Delta R_{jj} \geq 0.4$). This results in a drastic reduction of the $t\bar{t}$ background, leaving a very small number of events from the dileptonic decay mode of $t\bar{t}$. The effects of these cuts have been taken into account in the second column of Table II.⁵

In order to suppress the background from $Wb\bar{b}$, we can make use of the fact that a b quark produced from a top decay can be expected to have a large p_T due to the heavy top mass (a typical value is about one-third of the top quark mass). The $b\bar{b}$ jets from the $Wb\bar{b}$ background are produced by the decay of a virtual gluon, and should have a momen-

tum distribution that is more evenly distributed. We found that the cut $p_T^b \geq 30 \text{ GeV}$ reduces the background and signal in such a way as to provide the best enhancement of the significance of the signal. The effects of this cut can be seen in the fourth column of Table II.

It is also desirable to impose a cut on p_T^c . Because the signal process occurs in the s channel, and the W -gluon fusion background is t channel, the distribution of the p_T of the signal c jet should peak at a higher value than the light jet from W -gluon fusion. Adjusting the cut to find the value that provides the best enhancement of the significance of the signal leads us to $p_T^c \geq 30 \text{ GeV}$. As can be seen in the fifth column of Table II, this cut has virtually no effect on the signal, while slightly reducing the W -gluon fusion and $Wb\bar{b}$ backgrounds.

IV. DETERMINATION OF Λ

In order to set bounds on the parameter Λ , it is necessary to look for evidence of a signal distinguishable from background fluctuations. We require a 3σ effect as our criterion for judging the signal to be distinguishable from a background fluctuation, that is, we require the probability for the background to fluctuate up to the observed level to be less than 0.27%. The number of signal events, N_S , has a simple dependence on the integrated luminosity and Λ ,

$$N_S = \frac{L\alpha}{\Lambda^2}. \quad (13)$$

The coefficient α , which characterizes the acceptance of signal events multiplied by the signal cross section after extracting the factor $1/\Lambda^2$, is determined by our Monte Carlo study at $\Lambda = 2 \text{ TeV}$ and $L = 1 \text{ fb}^{-1}$ to be $\alpha = 616 \text{ TeV}^2 \text{ fb}^{-1}$. The number of background events, N_B , is just the integrated luminosity multiplied by the total background cross sections. Once N_B has been determined for a given L , we can determine the N_S that will provide a 3σ effect using Gaussian statistics (since N_B and $N_S \geq 10$). From N_S one can then determine the minimum Λ such that a 3σ effect is not observed at the integrated luminosity of interest. In Table III we list the constraints on Λ_{\min} , the minimum value of Λ for which new physics will show up in t - c - g couplings, for several different integrated luminosities provided a 3σ effect is not observed at the Tevatron.

We expect that because we are examining the high invariant mass $M_{t\bar{c}}$ region, the theoretical uncertainties due to the

⁴In our calculation, the width of the top quark is included via the Breit-Wigner prescription. For a 175 GeV top quark, the SM width is about 1.5 GeV.

⁵To this order, they do not have any effect on the other processes listed in Table II.

TABLE III. Λ_{\min} for several integrated luminosities.

L	Λ_{\min}	N_S	N_B
200 pb ⁻¹	2.5 TeV	19	41
1 fb ⁻¹	3.8 TeV	43	207
2 fb ⁻¹	4.5 TeV	61	414
10 fb ⁻¹	6.7 TeV	136	2070
20 fb ⁻¹	8.0 TeV	193	4140

choice of the scale, Q^2 , in α_S , and in the parton distribution functions used for calculations, should be small. (Note that in the relatively large x region, the parton distribution functions are well determined by deep inelastic scattering data.) In order to quantify this effect we have examined the signal cross section using $Q^2 = \sqrt{s}$ and $Q^2 = \sqrt{m_t^2 + p_T^2}$. We find that the cross sections in these two cases differ by about 17%, which can affect our determined Λ by about 10%.

V. DISCUSSION AND CONCLUSIONS

We have shown that it is possible to introduce an operator of dimension five into the QCD Lagrangian that couples the top and charm quarks to the gluon field. This operator can be constructed to respect the $SU(3)_C$ local gauge symmetry of QCD, and the broken symmetry $SU(2)_L \times U(1)_Y \rightarrow U(1)_{EM}$ realized nonlinearly, as in the chiral Lagrangian. Because the operator is dimension five, it is divided by a parameter with the dimension of mass, Λ , that characterizes the energy scale at which new physics will modify the t - c - g interactions.

We have completed a Monte Carlo study of the process $q\bar{q} \rightarrow t\bar{c}$ and the SM backgrounds present at the Tevatron to show how to enhance the ratio of the signal to the background to improve the limits one may set on the minimum value of Λ , Λ_{\min} . As shown in Table III, our results indicate that even with an integrated luminosity of 200 pb⁻¹, the lack of a 3σ signal at the Tevatron requires $\Lambda \geq 2.5$ TeV (assum-

⁶A 30% b -tagging efficiency will reduce the constraint on Λ_{\min} to about $\Lambda_{\min} \geq 1.7$ TeV.

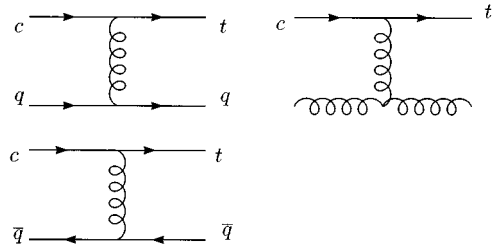

FIG. 2. Representative Feynman diagrams for top + light jet production.

ing a b -tagging efficiency of 60%).⁶ Assuming $\Lambda = 2.5$ TeV, there would be 19 signal events and 41 background events produced at the Tevatron with an integrated luminosity of 200 pb⁻¹. A higher integrated luminosity allows one to set even stronger limits on Λ . For instance, for 1 fb⁻¹ of data, $\Lambda \geq 3.8$ TeV if no signal is found at a 3σ level. If a signal is found, we expect at least 43 signal events with 207 background events. From Eq. (10) we see that if $\Lambda = 2.7$ TeV, the branching ratio $t \rightarrow cg$ should be about 13%. This suggests that a detailed study of the decay of the top quark can probe Λ , but because of large backgrounds from which this signal cannot easily be distinguished, study of $t\bar{c}$ production should provide a better way to set experimental bounds on Λ . Thus, a detailed study of single-top production at the Tevatron is useful in that it will allow one to set bounds on the possibility of this type of anomalous top quark coupling.

In this work, we did not consider the other possible single-top production processes $qc \rightarrow qt$, $\bar{q}\bar{c} \rightarrow t\bar{q}$, and $gc \rightarrow gt$ as shown in Fig. 2. We speculate that due to the large backgrounds discussed in Sec. III, it is necessary to impose a large p_T cut on the final state parton jet q , \bar{q} , or g . This cut should significantly reduce these contributions to the signal, making it difficult to observe. Further study is needed to better understand this.

ACKNOWLEDGMENTS

The authors would like to thank C.-P. Yuan and X. Zhang for helpful discussion. This work was supported in part by the NSF under Grant No. PHY-9309902.

[1] H. Fritzsch, Phys. Lett. **73B**, 317 (1978).
 [2] T. Han, R. D. Peccei, and X. Zhang, Nucl. Phys. **B454**, 527 (1995).
 [3] D. Amidei and C. Brock, Fermilab Report No. FERMILAB-PUB-96-082, 1996 (unpublished).
 [4] W. S. Hou, Phys. Lett. B **296**, 179 (1992).
 [5] C. Hill, Phys. Lett. B **345**, 483 (1995).
 [6] R. D. Peccei and X. Zhang, Nucl. Phys. **B337**, 269 (1990).
 [7] E. Malkawi and C.-P. Yuan, Phys. Rev. D **50**, 4462 (1994).
 [8] F. Feruglio, Int. J. Mod. Phys. A **8**, 4937 (1993).

[9] C.-P. Yuan (private communication).
 [10] T. Stelzer and S. Willenbrock, Phys. Lett. B **357**, 125 (1995).
 [11] D. Carlson, Ph.D. thesis, 1995.
 [12] D. Carlson and C.-P. Yuan, Phys. Lett. B **306**, 386 (1993).
 [13] Ian Hincliffe, in *Proceedings of the Workshop on Physics at Current Accelerators and the Supercolliders*, Argonne, Illinois, 1993, edited by J. L. Hewett *et al.*, (Argonne Report No. ANL-HEP-CP-93-92, Argonne, 1993), p. 679.