

Gauge-independent approach to resonant transition amplitudes

Joannis Papavassiliou

Department of Physics, New York University, 4 Washington Place, New York, New York 10003

Apostolos Pilaftsis*

Rutherford Appleton Laboratory, Chilton, Didcot, Oxon OX11 0QX, United Kingdom

(Received 6 July 1995)

We present a new gauge-independent approach to resonant transition amplitudes with nonconserved external currents, based on the pinch technique method. In the context of $2 \rightarrow 2$ and $2 \rightarrow 3$ scattering processes we show explicitly that the analytic results derived respect $U(1)_{\text{em}}$ gauge symmetry and do not depend on the choice of the $SU(2)_L$ gauge fixing. Our analytic approach treats, on equal footing, fermionic as well as bosonic contributions to the resummed gauge boson propagators, does not contain any residual spacelike threshold terms, shows the correct high-energy unitarity behavior, admits renormalization, and satisfies a number of other required properties, including the optical theorem. Even though our analysis has mainly focused on the standard model gauge bosons, our method can easily be extended to the top quark, and be directly applied to the study of unstable particles present in renormalizable models of new physics.

PACS number(s): 11.15.Bt, 11.15.Ex, 14.70.Fm

I. INTRODUCTION

Several years after the first experimental observations of decaying quantum-mechanical systems [1], Weisskopf and Wigner [2] formulated a theory for the time evolution of decaying states, which has been used with great success for the description of CP violation in the K_0 - \bar{K}_0 and other systems. This theory is, however, approximate, and deviations from its predictions are expected, when observations take place at very short or very long times as compared to the lifetime of the unstable particle [3]. Subsequently, Veltman [4] showed that an S matrix theory, where the dynamics of unstable particles is described in terms of initial and final asymptotic states, is unitary and causal, despite the presence of on-shell particle configurations.

The correct treatment of unstable particles has received a renewed attention within the framework of the S matrix perturbation theory, mainly because the straightforward generalization of the Breit-Wigner (BW) propagator derived from naive scalar field theories [4] to gauge field theories, violates the gauge symmetry [5-14]. This fact is perhaps not so surprising, since the naive resummation of the self-energy graphs takes into account higher order corrections, for *only* certain parts of the tree-level amplitude. Even though, as we will show, the amplitude possesses all the desired properties, this unequal treatment of its parts distorts subtle cancellations, resulting in numerous pathologies, which are artifacts of the method used. Evidently, a self-consistent calculational scheme needs be devised, which will exploit all the healthy field

theoretical properties intrinsic in every S -matrix element.

An early attempt in this direction has been based on the observation that the position of the complex pole is a gauge-independent (GI) quantity [6-8]. Exploiting this fundamental property of the S matrix, Stuart [7] has developed a perturbative approach in terms of three gauge-invariant quantities: the constant complex pole position of the resonant amplitude, the residue of the pole, and a q^2 -dependent nonresonant background term. Even though this approach, which is based on a Laurent series expansion of the resonant transition element [7], may eventually furnish a gauge-invariant result, the perturbative treatment of these three GI quantities [11] introduces unavoidably residual spacelike threshold terms, which become more apparent in CP -violating scenarios of new physics. In fact, the precise q^2 -dependent shape of a resonance [8] is reproduced, to a given loop order, by considering quantum corrections to the three GI quantities mentioned above [7, 11], while the spacelike threshold contributions, even though are shifted to higher orders, do not disappear completely.

Within the framework of the S matrix perturbation theory, it was suggested [5] that finite width effects can induce sizable CP violation and *resonantly* enhance CP -violating observables [15] in supersymmetric theories, and other extensions of the minimal standard model (SM) [16]. The quest of the proper BW form for a resonant W and t propagator [9, 10, 17] is equally important for processes, such as $e^+e^- \rightarrow W^+W^-$ [12], $e^-\gamma \rightarrow \mu^-\bar{\nu}_\mu\nu_e$ [13, 14, 18], etc.

In this paper, we present a new GI approach to resonant transition amplitudes implemented by the pinch technique (PT) [19-22]. The PT is an algorithm that systematically exploits the known field theoretical properties of the S matrix, which is the fundamental physical quantity of interest. Operationally, the PT leads to a

*Electronic address: pilaftsis@v2.rl.ac.uk

rearrangement of the Feynman graphs contributing to a gauge-invariant amplitude, in such a way as to define individually GI propagator, vertex, and boxlike structures. For example, the PT arranges the S matrix element T for the process $q_1\bar{q}_2 \rightarrow q_1\bar{q}_2$, where q_1, q_2 are two on-shell test quarks with masses m_1 and m_2 , in the form

$$T(s, t, m_1, m_2) = \widehat{T}_1(t) + \widehat{T}_2(t, m_1) + \widehat{T}_2(t, m_2) + \widehat{T}_3(s, t, m_1, m_2), \quad (1.1)$$

where the \widehat{T}_i ($i = 1, 2, 3$) are *individually* ξ independent. The parts of vertex and box graphs which are kinematically akin to propagators and enforce the gauge independence of $\widehat{T}_1(t)$, are called propagatorlike pinch parts. Similarly, vertexlike pinch parts of boxes enforce the gauge independence of $\widehat{T}_2(t)$.

The crucial novel ingredient we introduce in the context of resonant transition amplitudes is the proposition that the resummation of graphs must take place only *after* the amplitude of interest has been cast via the PT algorithm into manifestly GI subamplitudes, with distinct kinematic properties, order by order in perturbation theory. For example, it is the resummations of the \widehat{T}_1 which will provide the effective, manifestly GI, resummed propagators.

The main points of our approach have already presented in a brief communication [23]; in this paper we mainly focus on the detailed treatment of several technical issues. The outline of the present work is as follows. In Sec. II, we define the framework of our perturbative GI S matrix approach by considering the resonant reaction $e^- \bar{\nu}_e \rightarrow \mu^- \bar{\nu}_\mu$. Issues of resummation and the resummation procedure within the PT will be discussed in Secs. III and IV, respectively. In Sec. V, we show that the position of the pole does not get shifted when using the PT resummation algorithm in the stable particle theory—a heuristic proof is given in Appendix A. In Sec. VI, we further show that this is still true for the case of unstable particles. Section VII deals with issues related to unitarity of resonant processes. In Sec. VIII, we give an application of our approach to the resonant processes $\gamma e^- \rightarrow \mu^- \bar{\nu}_\mu \nu_e$ and $Q Q' \rightarrow e^- \bar{\nu}_e \mu^- \mu^+$, which involve the γWW and ZWW vertices, respectively. Further technical details of such reactions are relegated in Appendices B and C. Section IX contains our conclusions.

II. THE PROCESS $e^- \bar{\nu}_e \rightarrow \mu^- \bar{\nu}_\mu$

Despite the fact that the S matrix is well defined, the evaluation of physical processes has to rely on its perturbative expansion in the coupling constants of the theory, as there is not yet an analytic method to calculate the complete S -matrix amplitude. On the other hand, this perturbative approximation of S is not unique, and depends on the form of the expansion adopted, and, to some extent, on the renormalization prescription used to remove the ultraviolet (UV) divergences. However, the summation of all infinite perturbative contributions should formally reproduce the unique expression of the S -matrix element of the process under consideration. Al-

though the perturbative expansion itself may contain such difficulties, there are some well-defined features that characterize a consistent perturbative expansion of S matrix within gauge field theories.

(i) The expansion should obey a number of required properties, including unitarity (or equivalently the optical theorem) [4], causality [24], analyticity, etc. [25].

(ii) Since we are interested in renormalizable field theories based on Lagrangians which contain operators of dimension no higher than four and so have an inherent predictive power, the expansion under consideration should consistently admit renormalization.

(iii) The perturbative S matrix element should respect the fundamental gauge symmetries. In particular, since it represents a physical quantity, it should be independent on the choice of gauge used, which can only be shown to be the case with the help of Becchi-Rouet-Stora (BRS) transformations [26].

Conditions (i) and (iii) are the main source of problems, when considering resonant S matrix transition amplitudes. In what follows, we will discuss some of the crucial differences between our approach and the conventional S matrix perturbation theory. In the context of the latter, the one loop W -boson self-energy has the general form

$$\Pi_{\mu\nu}^{(\xi)}(q) = t_{\mu\nu}(q)\Pi_T^{(\xi)}(q^2) + \ell_{\mu\nu}(q)\Pi_L^{(\xi)}(q^2), \quad (2.1)$$

where

$$t_{\mu\nu}(q) = -g_{\mu\nu} + \frac{q_\mu q_\nu}{q^2},$$

$$\ell_{\mu\nu}(q) = \frac{q_\mu q_\nu}{q^2}. \quad (2.2)$$

The self-energy of Eq. (2.1) is a gauge-dependent quantity; in the conventional S -matrix approach it depends explicitly on the gauge parameter ξ . The two-point function for the mixing W^-G^- , Θ_μ , and G^-G^- self-energy, Ω , are also ξ dependent. Using the general form of Eq. (2.1) for the self-energy, the one loop resummed W propagator is given by

$$\Delta_{\mu\nu}^{(\xi)}(q) = \left[\Delta_{0\mu\nu}^{-1(\xi)}(q) - \Pi_{\mu\nu}^{(\xi)}(q) \right]^{-1}$$

$$= t_{\mu\nu}(q) \frac{1}{q^2 - M^2 - \Pi_T^{(\xi)}(q^2)} - \ell_{\mu\nu}(q) \frac{\xi}{q^2 - \xi[M^2 - \Pi_L^{(\xi)}(q^2)]}, \quad (2.3)$$

where

$$\Delta_{0\mu\nu}^{(\xi)}(q) = t_{\mu\nu}(q) \frac{1}{q^2 - M^2} - \ell_{\mu\nu}(q) \frac{\xi}{q^2 - \xi M^2}$$

$$= U_{\mu\nu}(q) - \frac{q_\mu q_\nu}{M^2} D_0^{(\xi)}(q^2). \quad (2.4)$$

In Eq. (2.4), $U_{\mu\nu}$ stands for the free W propagator in the unitary gauge, which has the form

$$U_{\mu\nu}(q) = \left(-g_{\mu\nu} + \frac{q_\mu q_\nu}{M^2} \right) \frac{1}{q^2 - M^2}$$

$$= t_{\mu\nu}(q) \frac{1}{q^2 - M^2} + \ell_{\mu\nu}(q) \frac{1}{M^2}, \quad (2.5)$$

and

$$D_0^{(\xi)}(q^2) = \frac{1}{q^2 - \xi M^2}, \quad (2.6)$$

is the tree-level propagator of the associated Goldstone boson G^+ in a general ξ gauge. Its resummed propagator reads

$$D^{(\xi)}(q^2) = \frac{1}{q^2 - \xi M^2 - \Omega^{(\xi)}(q^2)}. \quad (2.7)$$

For purposes of illustration, we have only considered the lowest order of resummation, where higher order W^-G^- mixing effects have not been taken into account. However, our conclusions will still be valid for the general case. Using the resummed ξ -dependent propagators given in Eqs. (2.3) and (2.7) for the calculation of a resonant process, such as $e^-\bar{\nu}_e \rightarrow \mu^-\bar{\nu}_\mu$, to a given order of perturbation theory, one can then verify easily that the ξ dependence does not disappear. The reason is that $\Pi_{\mu\nu}^{(\xi)}(q^2)$ is a ξ dependent quantity in a region not far away from the resonant point $q^2 = M^2$ (only at this point the self-energy is GI) and the propagators (2.3) and (2.7) induce ξ dependence to all orders, while ξ -dependent terms coming from vertices and box graphs can remove this gauge dependence only to a given order of the conventional perturbation theory. Instead, within our framework, the above problems associated with the resummed self-energies are absent, because the entire ξ dependence has been eliminated via the PT order by order in perturbation theory, *before* resummation takes place.

We will now consider an approach implemented by the

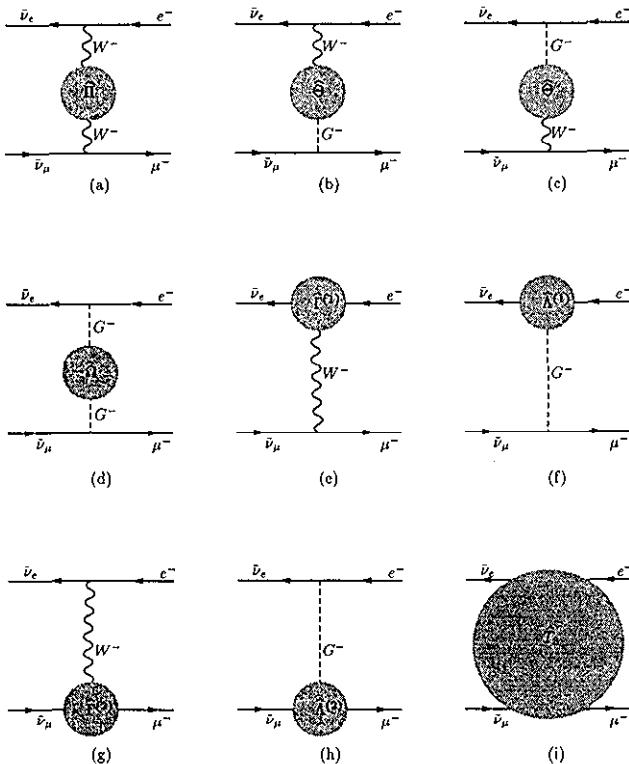

FIG. 1. The PT decomposition of the process $e^-\bar{\nu}_e \rightarrow \mu^-\bar{\nu}_\mu$ (the arrow of time shows downwards).

PT. Within the PT framework, the transition amplitude $T(s, t, m_i)$ of a $2 \rightarrow 2$ process, such as $e^-\bar{\nu}_e \rightarrow \mu^-\bar{\nu}_\mu$ shown in Fig. 1, can be decomposed as

$$T(s, t, m_i) = \hat{T}_1(s) + \hat{T}_2(s, m_i) + \hat{T}_3(s, t, m_i), \quad (2.8)$$

in terms of three individually GI quantities: a propagatorlike part (\hat{T}_1), a vertexlike piece (\hat{T}_2), and a part containing box graphs (\hat{T}_3). The important observation is that vertex and box graphs contain in general pieces, which are kinematically akin to self-energy graphs of the transition amplitude. The PT is a systematic way of extracting such pieces and appending them to the conventional self-energy graphs. In the same way, effective gauge-invariant vertices may be constructed, if after subtracting from the conventional vertices the propagatorlike pinch parts we add the vertexlike pieces coming from boxes. The remaining purely boxlike contributions are then also GI. Finally, the entire S matrix can be rearranged in the form of Eq. (2.8). In the specific example $e^-\bar{\nu}_e \rightarrow \mu^-\bar{\nu}_\mu$, the piece \hat{T}_1 consists of three *individually* GI quantities: The WW self-energy $\hat{\Pi}_{\mu\nu}$ [Fig. 1(a)], the W^-G^- mixing term¹ $\hat{\Theta}_\mu$ [Figs. 1(b) and 1(c)], and the GG self-energy $\hat{\Omega}$ [Fig. 1(d)]. Similarly, $\hat{T}_2(s, m_i)$ consists of two pairs of GI vertices $W e^-\bar{\nu}_e$, $G e^-\bar{\nu}_e$ [$\hat{\Gamma}_\mu^{(1)}$ and $\hat{\Lambda}^{(1)}$, given in Figs. 1(e) and 1(f), respectively] and $W \mu^-\bar{\nu}_\mu$ and $G \mu^-\bar{\nu}_\mu$ [$\hat{\Gamma}_\mu^{(2)}$ and $\hat{\Lambda}^{(2)}$, in Figs. 1(g) and 1(h)]. In addition to being GI, the PT self-energies and vertices possess a very crucial property, e.g., they satisfy *tree-level* Ward identities, summarized as

$$q^\mu q^\nu \hat{\Pi}_{\mu\nu} - 2Mq^\mu \hat{\Theta}_\mu + M^2 \hat{\Omega} = 0, \quad (2.9)$$

$$q^\mu \hat{\Pi}_{\mu\nu} - M \hat{\Theta}_\nu = 0, \quad (2.10)$$

$$q^\mu \hat{\Theta}_\mu - M \hat{\Omega} = 0, \quad (2.11)$$

$$q^\mu \hat{\Gamma}_\mu^i - M \hat{\Lambda}^i = 0, \quad (i = 1, 2). \quad (2.12)$$

These Ward identities are a direct consequence of the requirement that \hat{T}_1 and \hat{T}_2 are fully ξ independent. As explained in detail in [20, 27], after having canceled via the PT all ξ dependences inside loops, these Ward identities enforce the final cancellations of the ξ dependences stemming from the tree-level propagators. In fact, the derivation of the Ward identities does not require knowledge of the closed expressions of the quantities involved. To see how the final ξ dependences cancel by virtue of the aforementioned Ward identities we turn to \hat{T}_1 . After the PT process has been completed, \hat{T}_1 reads

¹In fact, we define $\hat{\Theta}_\mu(q) = \hat{\Pi}_{\mu\nu}^{W^-G^-}(q) = \hat{\Pi}_{\mu\nu}^{G^-W^-}(q) = -\hat{\Pi}_{\mu\nu}^{W^+G^+}(q) = -\hat{\Pi}_{\mu\nu}^{G^+W^+}(q)$, where the momentum always flows from the left to the right in the language of Feynman diagrams.

$$\begin{aligned}
\widehat{T}_1 &= \Gamma_0^\sigma \Delta_{0\sigma\rho}^{(\xi)} \Gamma_0^\rho + \Gamma_0^\sigma \Delta_{0\sigma\mu}^{(\xi)} \widehat{\Pi}^{\mu\nu} \Delta_{0\nu\rho}^{(\xi)} \Gamma_0^\rho \\
&\quad + \Lambda_0 D_0^{(\xi)} \Lambda_0 + \Lambda_0 D_0^{(\xi)} \widehat{\Omega} D_0^{(\xi)} \Lambda_0 \\
&\quad + \Gamma_0^\sigma \Delta_{0\sigma\mu}^{(\xi)} \widehat{\Theta}^\mu D_0^{(\xi)} \Lambda_0 + \Lambda_0 D_0^{(\xi)} \widehat{\Theta}^\nu \Delta_{\nu\rho}^{(\xi)} \Gamma_0^\rho \\
&= \Gamma_0^\sigma U_{\sigma\rho} \Gamma_0^\rho + \Gamma_0^\sigma U_{\sigma\mu} \widehat{\Pi}^{\mu\nu} U_{\nu\rho} \Gamma_0^\rho, \tag{2.13}
\end{aligned}$$

where Γ_0^μ and Λ_0 are the tree-level W -boson and would-be Goldstone boson couplings to the fermions, respectively. In the second step of Eq. (2.13), the Ward identities of Eqs. (2.10) and (2.11) were used. Clearly, all ξ dependence has disappeared. We can actually go one step further and rewrite this last ξ -independent expression as a sum of two pieces, one transverse and one longitudinal, by employing Eq. (2.5) and the Ward identities of Eqs. (2.10) and (2.11). Indeed, if we write $\widehat{\Pi}_{\mu\nu}$ in the form of Eq. (2.1), i.e., $\widehat{\Pi}_{\mu\nu} = t_{\mu\nu} \widehat{\Pi}_T + \ell_{\mu\nu} \widehat{\Pi}_L$ we have

$$\widehat{\Pi}_T = -\frac{1}{3} \left(\widehat{\Pi}_\sigma^\sigma - \frac{M^2}{q^2} \widehat{\Omega} \right), \tag{2.14}$$

$$\widehat{\Pi}_L = \frac{M^2}{q^2} \widehat{\Omega}, \tag{2.15}$$

and so \widehat{T}_1 may be written as

$$\begin{aligned}
\widehat{T}_1 &= \Gamma_0^\mu \left[\frac{t_{\mu\nu}}{q^2 - M^2} \left(1 + \frac{\widehat{\Pi}_T}{q^2 - M^2} \right) \right. \\
&\quad \left. + \frac{\ell_{\mu\nu}}{M^2} \left(1 + \frac{\widehat{\Pi}_L}{M^2} \right) \right] \Gamma_0^\nu. \tag{2.16}
\end{aligned}$$

Let us now assume for a moment that the PT decomposition holds to any order in perturbation theory (we will extensively discuss the validity of this assumption in the next sections). In such a case, summing up contributions from all orders in perturbation theory we obtain, for \widehat{T}_1 (suppressing contraction of Lorentz indices),

$$\begin{aligned}
\widehat{T}_1 &= \Gamma_0 U \Gamma_0 + \Gamma_0 U \widehat{\Pi} U \Gamma_0 + \Gamma_0 U \widehat{\Pi} U \widehat{\Pi} U \Gamma_0 + \dots \\
&= \Gamma_0 \widehat{\Delta} \Gamma_0, \tag{2.17}
\end{aligned}$$

with

$$\begin{aligned}
\widehat{\Delta}_{\mu\nu}(q) &= t_{\mu\nu}(q) \frac{1}{q^2 - M^2 - \widehat{\Pi}_T(q^2)} \\
&\quad + \ell_{\mu\nu}(q) \frac{1}{M^2 - \widehat{\Pi}_L(q^2)}. \tag{2.18}
\end{aligned}$$

It is important to emphasize that the propagator of Eq. (2.17) is *process independent*; one arrives at exactly the same expression for $\widehat{\Delta}_{\mu\nu}$, $\widehat{\Pi}_T$, and $\widehat{\Pi}_L$, regardless of the quantum numbers of the external particles [28]. In the last step of Eq. (2.17), we have assumed that the analytic continuation of the result to the resonant point $q^2 = M^2$ will not cause any theoretical difficulty. In the case of the conventional propagator such an assumption is justified, since the resonant propagator can be directly derived as a solution of the corresponding Dyson-Schwinger (DS) integral equation, which is well defined, even at the singular point $q^2 = M^2$. The reason is that the DS integral

equations can be deduced directly from the action of the theory, through a variational principle [29]. Even though the corresponding task has not been yet accomplished for the SD equation governing the dynamics of PT Green's functions [30], we will consider the analytic continuation of our results as a plausible assumption. We will therefore carry out our diagrammatic approach in terms of Feynman graphs and then continue analytically our results to describe the physics of unstable particles.

III. ISSUES OF RESUMMATION IN THE PT

Even though the PT has been developed in detail to one loop, its generalization to higher orders has not yet been presented in the literature. In this section we will briefly outline how this generalization proceeds; the full presentation will be given elsewhere [31].

Here we will focus particularly on issues of resummation, and show that the gauge-invariant PT self-energy may be resummed in the same way as one carries out the Dyson summation for the conventional self-energy. In other words, the PT self-energies have *the same* resummation properties as regular self-energies. The crucial point is that, even though contributions from vertices and boxes are instrumental for the definition of the PT self-energies, their resummation does *not* require a corresponding resummation of vertex or box parts. In order to see that, consider the usual Dyson series for the conventional self-energy of QCD. The building blocks of this series are strings of the basic self-energy $\Pi_{\mu\nu}(q) = t_{\mu\nu}(q) \Pi(q^2)$, computed to a given order in perturbation theory, which repeats itself. The net effect of the resummation of all such strings is to bring the quantity $\Pi(q^2)$ in the denominator of the free gluon propagator $\Delta_{0\mu\nu}$.

Let us now see how one can resum, i.e., bring in the denominator the one loop PT self-energy. To that end, consider a string of regular one loop self-energies (in any gauge) in QCD. Clearly, in order to convert the string of self-energies into a string of PT self-energies one needs to furnish the missing pinch parts (in the same gauge). At one loop any pinch contribution has the general form $[\Delta_0^{\mu\rho}(q)]^{-1} V^P(q)$ (for propagatorlike pinch parts coming from vertices) and $[\Delta_0^{\mu\rho}(q)]^{-1} B^P(q) [\Delta_0^{\rho\nu}(q)]^{-1}$ for propagatorlike pinch parts coming from boxes). To simplify the picture (without loss of generality) let us work in the Feynman gauge $\xi = 1$. Then at one loop the only pinch contribution comes from vertices (beyond one loop we have propagatorlike pinch parts from boxes, even for $\xi = 1$). So for each conventional $\Pi_{\mu\nu}(q)$ we need to supply a factor $[\Delta_0^{\mu\nu}(q)]^{-1} \frac{1}{2} V^P(q) + \frac{1}{2} V^P(q) [\Delta_0^{\mu\nu}(q)]^{-1}$. Some of the necessary pinch contributions will be provided by graphs containing at least one vertex, such as in Figs. 2(b), 2(c), and 2(d). These existing pinch parts are however not sufficient for converting all $\Pi_{\mu\nu}$ into $\widehat{\Pi}_{\mu\nu}$. If we add by hand (and subsequently subtract) the missing pieces to each $\Pi_{\mu\nu}$, (a) the string has been converted into a string with $\Pi_{\mu\nu} \rightarrow \widehat{\Pi}_{\mu\nu}$ and (b) the leftovers, due to the presence of the inverse $[\Delta_0^{\mu\nu}]^{-1}$, are effectively one-particle *irreducible*.

To see that in detail, let us turn to the specific example shown in Fig. 2. The original string L with two one loop self-energies reads (there is an overall factor $t_{\mu\nu}$ which is factored out)

$$L = \frac{1}{q^2} \left[\Pi_1 \left(\frac{1}{q^2} \right) \Pi_1 \right] \frac{1}{q^2} \quad (3.1)$$

and is accompanied by the three strings L_1 , L_2 , and L_3 shown in Figs. 2(b), 2(c), and 2(d), respectively. After extracting the pinch contributions from the one loop vertices of L_1 , L_2 , and L_3 as is depicted in Figs. 2(e), 2(f), and 2(g), we receive the propagatorlike contributions

$$\begin{aligned} L_1^P &= \frac{1}{q^2} \left[q^2 \frac{1}{2} V_1^P \left(\frac{1}{q^2} \right) \Pi_1 \right] \frac{1}{q^2}, \\ L_2^P &= \frac{1}{q^2} \left[\Pi_1 \left(\frac{1}{q^2} \right) \frac{1}{2} V_1^P q^2 \right] \frac{1}{q^2}, \\ L_3^P &= \frac{1}{q^2} \left[q^2 \frac{1}{2} V_1^P \left(\frac{1}{q^2} \right) \frac{1}{2} V_1^P q^2 \right] \frac{1}{q^2}. \end{aligned} \quad (3.2)$$

Returning to L , we know that in order for a Π to be

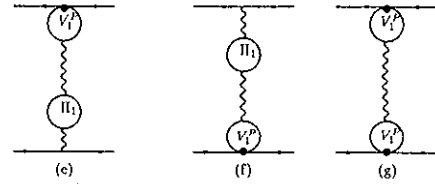
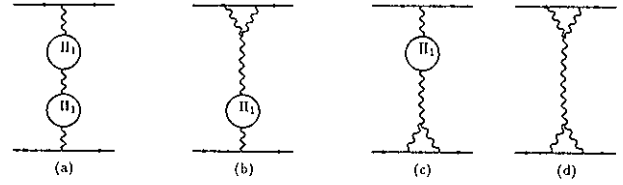

FIG. 2. The PT method applied to the scattering $q\bar{q} \rightarrow q'q'$ at the two-loop QCD order.

converted into a $\hat{\Pi}$ an amount $(q^2 \frac{1}{2} V^P + \frac{1}{2} V^P q^2)$ must be added. Let us call \hat{L} the corresponding string containing two $\hat{\Pi}_1$ instead of two Π . Let us see how we can construct it from the existing pieces:

$$\begin{aligned} \hat{L} &= \frac{1}{q^2} \left[\hat{\Pi}_1 \left(\frac{1}{q^2} \right) \hat{\Pi}_1 \right] \frac{1}{q^2} \\ &= \frac{1}{q^2} \left[\Pi_1 + q^2 \frac{1}{2} V_1^P + \frac{1}{2} V_1^P q^2 \right] \left(\frac{1}{q^2} \right) \left[\Pi_1 + q^2 \frac{1}{2} V_1^P + \frac{1}{2} V_1^P q^2 \right] \frac{1}{q^2} \\ &= L + L_1^P + L_2^P + L_3^P + \frac{1}{q^2} R \frac{1}{q^2}, \end{aligned} \quad (3.3)$$

where

$$\begin{aligned} R &= \Pi_1 \frac{1}{2} V_1^P + \frac{1}{2} V_1^P \Pi_1 \\ &+ \frac{1}{4} (V_1^P V_1^P q^2 + q^2 V_1^P V_1^P + V_1^P q^2 V_1^P). \end{aligned} \quad (3.4)$$

We see that in addition to the existing pieces L , L_1^P , L_2^P , and L_3^P , one needs to supply R . As advertised, R has the very important property that it is effectively one-particle irreducible. So, R has the same structure as the one-particle irreducible two-loop self-energy graphs shown in Fig. 3. Evidently, $-R$ together with the genuine two-loop vertex and box pinch contributions displayed in Fig. 4 will then convert the conventional two-loop self-energy into the GI two-loop PT self-energy. So, the general form of the QCD propagatorlike pinch contributions in the Feynman gauge, to a given loop order n in perturbation theory, has the form $t_{\mu\nu}(q)\Pi_n^P(q^2)$, with

$$\Pi_n^P(q^2) = q^2 V_n^P(q^2) + (q^2)^2 B_n^P(q^2) + R_n^P(q^2). \quad (3.5)$$

For example, propagatorlike pinch contributions from

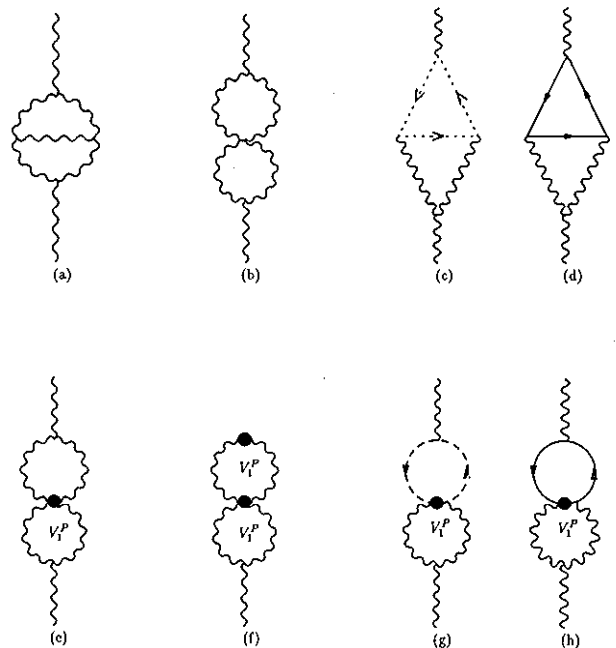

FIG. 3. Two-loop PT contributions to the gluon vacuum polarization.

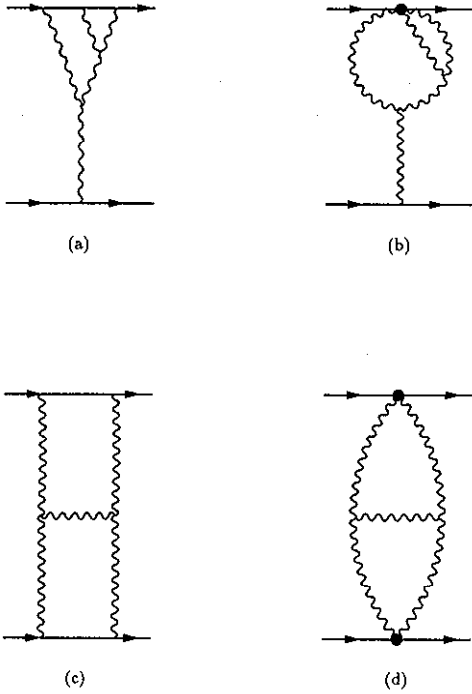

FIG. 4. Typical two-loop vertex and box graphs giving PT contributions to the two-loop PT self-energy.

one loop vertex graphs have the general form of the first term in the right-hand side (RHS) of Eq. (3.5), whereas one-loop contributions from boxes have the general form of the second term. The $R_n^P(q^2)$ contains contributions of all terms described in (b). Clearly, $R_1^P(q^2) = 0$, but $R_n^P(q^2) \neq 0$ for $n > 1$. For example, for $n = 2$ we have that R_2^P is the negative of R of Eq. (3.4). In this notation, R_2^P reads

$$R_2^P(q^2) = -R = -\left(\Pi_1 V_1^P + \frac{3}{4}q^2 V_1^P V_1^P\right). \quad (3.6)$$

Obviously, the R_n^P terms consist in general of products of lower order conventional self-energies $\Pi_k(q^2)$, and lower order pinch contributions V_ℓ^P and/or B_ℓ^P , with $k + \ell = n$.

We emphasize that the procedure described above has not been tailored for the particular needs of the present problem, but it is of general validity. In fact, this is the way the PT must be generalized to higher orders: one has to first convert a subset of diagrams *locally* into the corresponding PT subsets using the results of the previous order, by adding (and subsequently subtracting) the appropriate pinch parts, every time they are not present. Because of their characteristic structure the extra pieces give rise to diagrams which then can (and they should) be allotted to the remaining graphs, and they are crucial for their gauge independence. In this way, one can rewrite the S matrix at each order in perturbation theory, into manifestly GI subamplitudes, with the characteristic properties one knows from one loop. In fact, it is of particular importance to explicitly demonstrate that the procedure described above will indeed give rise to a GI

two-loop self-energy, whose divergent part will coincide with the GI two-loop QCD β function. Results in this direction will be presented in detail in [31].

We conclude this section with some technical remarks. It has been known for years that when computing the PT Green's functions any convenient gauge may be chosen, as long as one properly accounts for the pinch contributions within that gauge [19]. In the context of the "renormalizable" R_ξ gauges the most convenient gauge-fixing choice is the Feynman gauge ($\xi = 1$). This is so because the longitudinal parts of the gauge boson propagators, which can pinch, vanish for $\xi = 1$, and the only possibility for pinching stems from the tree-boson vertices. As was recently realized [32], the task of the PT rearrangement of the S matrix can be further facilitated, if one quantizes the theory in the context of the background field method (BFM) [33]. Even though the Feynman rules obtained via the BFM are rather involved, they become particularly convenient for one loop pinching, if one chooses the Feynman gauge ($\xi_Q = 1$) inside the quantum loops. In fact, all possible one loop pinch contributions are zero in this gauge, e.g., $V_1^P|_{\xi_Q=1} = B_1^P|_{\xi_Q=1} = 0$. Consequently, the one loop PT Green's functions (which one can obtain for *every* gauge) are *identical* to the *conventional* Green's functions, calculated in the Feynman gauge of the BFM. This correspondence between PT and BFM at $\xi_Q = 1$ breaks down for the two-loop purely bosonic part [34]. Therefore, $V_n^P|_{\xi_Q=1} \neq 0$ and $B_n^P|_{\xi_Q=1} \neq 0$, for $n > 1$. The technical details leading to these conclusions will be presented in [31].

IV. PT RESUMMATION WITH NONCONSERVED CURRENTS

We now describe how to generalize the form of \hat{T}_1 , presented in Eq. (2.13) for the one loop case, to higher orders. In particular we want to show that when the external currents are nonconserved, all possible GI propagatorlike strings assume the form of Eq. (2.16). For definiteness, we concentrate on the case where the external currents are charged. Exactly analogous arguments hold for neutral currents. To accomplish that we must follow a three-step procedure.

(a) As described in the previous section, if we work at loop order n in perturbation theory, the strings containing conventional $\Pi_{\mu\nu}$, Θ_μ , and Ω self-energies (of individual order less than n , but of combined order n) must be converted to the corresponding PT strings containing $\hat{\Pi}_{\mu\nu}$, $\hat{\Theta}_\mu$, and $\hat{\Omega}$, i.e., we must replace conventional with "hatted" quantities. In doing so we use the formulas and methodology developed in [20]. As in the previous section, we assume that the necessary pinch parts form the lower orders are known; in particular, the missing pinch contributions are supplied by hand, and subsequently subtracted. The leftovers are effectively one-particle irreducible and will be added to the corresponding $\Pi_{\mu\nu}$, Θ_μ , and Ω of order n . All such terms, together with the normal pinch parts from box and vertex graphs of order n , will finally give rise to the $\hat{\Pi}_{\mu\nu}$, $\hat{\Theta}_\mu$, and $\hat{\Omega}$ of that order.

(b) By close analogy to Eq. (3.5), the general form of the transverse propagatorlike pinch contribution to the massive gauge boson is given by

$$\Pi_n^P(q^2) = (q^2 - m_0^2)V_n^P(q^2) + (q^2 - m_0^2)^2 B_n^P(q^2) + R_n^P(q^2). \quad (4.1)$$

The generic form of R_n^P is also very similar; the R_2^P for example is simply

$$R_2^P = - \left(\Pi_1 V_1^P + \frac{3}{4}(q^2 - m_0^2)V_1^P V_1^P \right). \quad (4.2)$$

Of course, the closed expressions of the individual V_n^P , B_n^P , and R_n^P are in general different from the QCD case.

It is important to notice that R_n^P contains a nonzero number of terms which are *not* explicitly proportional to $(q^2 - m_0^2)$; this is so because, as explained above, the explicit $[\Delta_0^{\mu\nu}]^{-1}$ in front of the $\Pi_k(q^2)$ cancels against one of the $\Delta_0^{\mu\nu}$ of the string.

(c) When all possible strings have been converted to PT strings, one can show that due to the Ward identities in Eqs. (2.9)–(2.11), they finally reorganize themselves into two different types of GI strings, \widehat{T}_1^t and \widehat{T}_1^l of the form

$$[\widehat{T}_1^t]_{\mu\nu} = t_{\mu\nu} D_0 \widehat{\Pi}_T^{i_1} D_0 \widehat{\Pi}_T^{i_2} D_0 \{ \dots \} D_0 \widehat{\Pi}_T^{i_k-1} D_0 \widehat{\Pi}_T^{i_k} D_0 \quad (4.3)$$

and

$$[\widehat{T}_1^l]_{\mu\nu} = \ell_{\mu\nu} \left(\frac{1}{M^2} \right) \widehat{\Pi}_L^{i_1} \left(\frac{1}{M^2} \right) \widehat{\Pi}_L^{i_2} \left(\frac{1}{M^2} \right) \{ \dots \} \left(\frac{1}{M^2} \right) \widehat{\Pi}_L^{i_k-1} \left(\frac{1}{M^2} \right) \widehat{\Pi}_L^{i_k} \left(\frac{1}{M^2} \right). \quad (4.4)$$

Here, $D_0 \equiv D_0^{(\xi=1)} = (q^2 - M^2)^{-1}$ defined in Eq. (2.6), $\widehat{\Pi}_T^{i_j}$ is the PT transverse WW self-energy of loop order i_j , $\widehat{\Pi}_L^{i_j}$ is the PT G^-G^- self-energy, and $\sum_{j=1}^k (i_j) = n$. Of course, for resummation purposes to a given loop order n , we have to identify all the possible combinatorial strings of self-energies in Eqs. (4.3) and (4.4), which will yield the resummed propagator of order n .

To give a concrete example, let us consider the entire set of possible strings at $n = 2$, for the process $e^- \bar{\nu}_e \rightarrow \mu^- \bar{\nu}_\mu$ shown in Fig. 5. Their explicit expressions are

$$\begin{aligned} \text{Fig. (a)} &= \left(U_{\mu\rho} - \frac{q_\mu q_\rho}{M^2} D_0^{(\xi)} \right) \widehat{\Pi}^{\rho\sigma} \left(U_{\sigma\lambda} - \frac{q_\sigma q_\lambda}{M^2} D_0^{(\xi)} \right) \widehat{\Pi}^{\lambda\tau} \left(U_{\tau\nu} - \frac{q_\tau q_\nu}{M^2} D_0^{(\xi)} \right), \\ \text{(b)} &= \frac{q_\mu}{M} D_0^{(\xi)} \widehat{\Theta}^\rho \left(U_{\rho\sigma} - \frac{q_\rho q_\sigma}{M^2} D_0^{(\xi)} \right) \widehat{\Pi}^{\sigma\tau} \left(U_{\tau\nu} - \frac{q_\tau q_\nu}{M^2} D_0^{(\xi)} \right), \\ \text{(c)} &= \left(U_{\mu\rho} - \frac{q_\mu q_\rho}{M^2} D_0^{(\xi)} \right) \widehat{\Theta}^\rho D_0^{(\xi)} \widehat{\Theta}^\tau \left(U_{\tau\nu} - \frac{q_\tau q_\nu}{M^2} D_0^{(\xi)} \right), \\ \text{(d)} &= \frac{q_\mu}{M} D_0^{(\xi)} \widehat{\Omega} D_0^{(\xi)} \widehat{\Theta}^\tau \left(U_{\tau\nu} - \frac{q_\tau q_\nu}{M^2} D_0^{(\xi)} \right), \\ \text{(e)} &= \left(U_{\mu\rho} - \frac{q_\mu q_\rho}{M^2} D_0^{(\xi)} \right) \widehat{\Theta}^\rho D_0^{(\xi)} \widehat{\Omega} D_0^{(\xi)} \frac{q_\nu}{M}, \\ \text{(f)} &= \frac{q_\mu}{M} D_0^{(\xi)} \widehat{\Omega} D_0^{(\xi)} \widehat{\Omega} D_0^{(\xi)} \frac{q_\nu}{M}, \\ \text{(g)} &= \left(U_{\mu\rho} - \frac{q_\mu q_\rho}{M^2} D_0^{(\xi)} \right) \widehat{\Pi}^{\rho\sigma} \left(U_{\sigma\tau} - \frac{q_\sigma q_\tau}{M^2} D_0^{(\xi)} \right) \widehat{\Theta}^\tau D_0^{(\xi)} \frac{q_\nu}{M}, \\ \text{(h)} &= \frac{q_\mu}{M} D_0^{(\xi)} \widehat{\Theta}^\rho \left(U_{\rho\sigma} - \frac{q_\rho q_\sigma}{M^2} D_0^{(\xi)} \right) \widehat{\Theta}^\sigma D_0^{(\xi)} \frac{q_\nu}{M}. \end{aligned} \quad (4.5)$$

It is now straightforward to prove that due to the Ward identities of Eqs. (2.10) and (2.11) all remaining ξ dependences cancel. To see that we can simply isolate powers of $D^{(\xi)}$ and verify that their cofactors, by virtue of the

Ward identities add up to zero (this is essentially the approach presented in [27]). Equivalently, we notice that the above strings may be combined pairwise [(a) with (b), (c) with (d), (e) with (f), and (g) with (h)], to yield

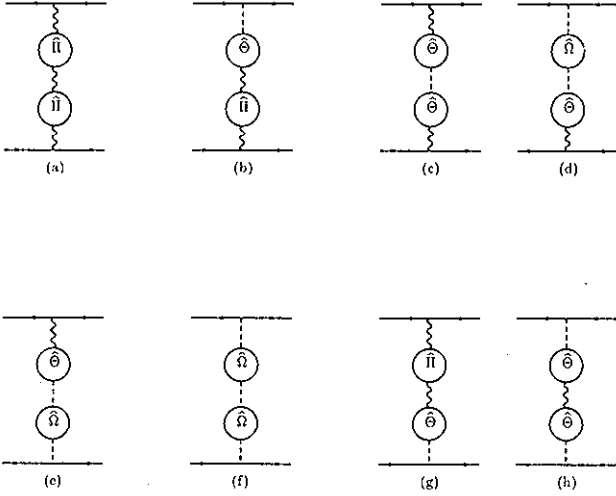

FIG. 5. The propagatorlike part \hat{T}_1 of the transition element for the process $e^- \bar{\nu}_e \rightarrow \mu^- \bar{\nu}_\mu$ at the two-loop electroweak order.

[after using Eqs. (2.10) and (2.11)]:

$$\begin{aligned}
 (a) + (b) &= U_{\mu\rho} \hat{\Pi}^{\rho\sigma} \left(U_{\sigma\lambda} - \frac{q_\sigma q_\lambda}{M^2} D_0^{(\xi)} \right) \hat{\Pi}^{\lambda\tau} \\
 &\quad \times \left(U_{\tau\nu} - \frac{q_\tau q_\nu}{M^2} D_0^{(\xi)} \right), \\
 (c) + (d) &= U_{\mu\rho} \hat{\Theta}^\rho D_0^{(\xi)} \hat{\Theta}^\tau \left(U_{\tau\nu} - \frac{q_\tau q_\nu}{M^2} D_0^{(\xi)} \right), \\
 (e) + (f) &= U_{\mu\rho} \hat{\Theta}^\rho D^{(\xi)} \hat{\Omega} D_0^{(\xi)} \frac{q_\nu}{M}, \\
 (g) + (h) &= U_{\mu\rho} \hat{\Pi}^{\rho\sigma} \left(U_{\sigma\tau} - \frac{q_\sigma q_\tau}{M^2} D_0^{(\xi)} \right) \hat{\Theta}^\tau D_0^{(\xi)} \frac{q_\nu}{M}.
 \end{aligned} \tag{4.6}$$

We can then further combine (a)+(b) with (g)+(h) and (c)+(d) with (e)+(f):

$$\begin{aligned}
 (a) + (b) + (g) + (h) &= U_{\mu\rho} \hat{\Pi}^{\rho\sigma} \left(U_{\sigma\lambda} - \frac{q_\sigma q_\lambda}{M^2} D_0^{(\xi)} \right) \\
 &\quad \times \hat{\Pi}^{\lambda\tau} U_{\tau\nu}, \\
 (c) + (d) + (e) + (f) &= U_{\mu\rho} \hat{\Theta}^\rho D_0^{(\xi)} \hat{\Theta}^\tau U_{\tau\nu}
 \end{aligned} \tag{4.7}$$

which finally gives

$$[\hat{T}_1]_{\mu\nu} = U_{\mu\rho} \hat{\Pi}^{\rho\sigma} U_{\sigma\lambda} \hat{\Pi}^{\lambda\tau} U_{\tau\nu}. \tag{4.8}$$

We may now write the $[\hat{T}_1]_{\mu\nu}$ of Eq. (4.8) as the sum of two pieces, $[\hat{T}_1^t]_{\mu\nu}$ and $[\hat{T}_1^l]_{\mu\nu}$, of the general form advertised in Eqs. (4.3) and (4.4), respectively. Indeed, using the identity of Eq. (2.5), and the Ward identities, we obtain

$$\begin{aligned}
 [\hat{T}_1]_{\mu\nu} &= t_{\mu\nu} D_0 \hat{\Pi}_T D_0 \hat{\Pi}_T D_0 + \ell_{\mu\nu} \left(\frac{1}{M^2} \right) \hat{\Pi}_L \left(\frac{1}{M^2} \right) \\
 &\quad \times \hat{\Pi}_L \left(\frac{1}{M^2} \right) \\
 &= [\hat{T}_1^t]_{\mu\nu} + [\hat{T}_1^l]_{\mu\nu}.
 \end{aligned} \tag{4.9}$$

It is obvious how to generalize the above arguments to

an arbitrary loop order n , which will formally lead to the resummed propagator $\hat{\Delta}_{\mu\nu}$ stated in Eq. (2.18) in the limit $n \rightarrow \infty$.

V. THE POSITION OF THE POLE IN THE PT

Another important issue in the context of the PT is the following. It is known that even though the conventional gauge boson self-energy is gauge dependent, the position of the pole is a GI quantity [6, 7]. On the other hand, the PT self-energy is by construction GI for all values of q^2 , and therefore its pole is also guaranteed to be GI. Given the fact that the pole position of the conventional propagator is related to physical quantities (mass and width) it is important to inquire, whether or not the PT pole position is different from that of the conventional one. It turns out that, to any order in perturbation theory, the two poles are *identical*. Put in different words, if one works at loop order n in perturbation theory, the two poles differ by a *gauge-independent* amount, which is of order $n+1$. This may come as no surprise since the PT seems to have the general property of not affecting quantities which are already GI.

In order to gain some intuition, let us first concentrate on the simpler case of a stable particle, and show that its mass does not get shifted by the PT. The conventional propagator $\Delta_{\mu\nu}(q)$ (computed at some gauge), and the PT propagator $\hat{\Delta}_{\mu\nu}(q)$ have the form

$$\Delta_{\mu\nu}(q) = \frac{-ig_{\mu\nu}}{q^2 - m_0^2 - \Pi(q^2)} + \dots \tag{5.1}$$

and

$$\hat{\Delta}_{\mu\nu}(q) = \frac{-ig_{\mu\nu}}{q^2 - m_0^2 - \hat{\Pi}(q^2)} + \dots, \tag{5.2}$$

where the ellipses denote the omission of terms proportional to $q^\mu q^\nu$. The corresponding masses m and \hat{m} , respectively, are defined as the solution of the following two equations:

$$m^2 = m_0^2 + \Pi(m^2) \tag{5.3}$$

and

$$\hat{m}^2 = m_0^2 + \hat{\Pi}(\hat{m}^2). \tag{5.4}$$

In perturbation theory clearly $m^2 = m_0^2 + \sum_1^\infty g^{2n} C_n$ and $\hat{m}^2 = m_0^2 + \sum_1^\infty g^{2n} \hat{C}_n$, and to zeroth order $m^2 = \hat{m}^2 = m_0^2$. Therefore,

$$\hat{m}^2 - m^2 = O(g^2). \tag{5.5}$$

At one loop it is easy to see what happens. To begin with, to any order in perturbation theory

$$\hat{\Pi}_n(q^2) = \Pi_n(q^2) + \Pi_n^P(q^2). \tag{5.6}$$

The general form of the one loop $\Pi_1^P(q^2)$, in any gauge, is given by

$$\Pi_1^P(q^2) = (q^2 - m_0^2)V_1^P(q^2) + (q^2 - m_0^2)^2 B_1^P(q^2), \quad (5.7)$$

and of course $R_1^P = 0$ for every gauge; in addition, in the Feynman gauge $B_1^P = 0$. So, from Eqs. (5.3)–(5.7) and assuming that $V_1^P(\hat{m}^2)$ and $B_1^P(\hat{m}^2)$ are nonsingular, we have that

$$\hat{m}_1^2 = m_0^2 + \Pi_1(\hat{m}^2) + O(g^4) \quad (5.8)$$

$$= m_1^2 + O(g^4) \quad (5.9)$$

from which follows that $C_1 = \hat{C}_1$.

The nontrivial step in generalizing this proof to higher orders is to observe that not all pinch contributions in the previous equation contribute terms of higher order. Indeed, as already mentioned in Sec. IV, the R^P terms of Eq. (4.1) do not always have a characteristic factor $(q^2 - m_0^2)$ in front, because it has been cancelled by an internal propagator of the string. Such terms are *not* of higher order, as is the case with the graphs which are of the form given in Eq. (5.7). To see why such contributions are instrumental for our proof, let us repeat the previous calculation, in the two-loop case. At the two-loop order, m^2 and \hat{m}^2 are given by

$$m^2 = m_0^2 + \Pi_1(m^2) + \Pi_2(m^2) \quad (5.10)$$

and

$$\hat{m}^2 = m_0^2 + \Pi_1(\hat{m}^2) + \Pi_2(\hat{m}^2) + \Pi_1^P + \Pi_2^P, \quad (5.11)$$

where

$$\begin{aligned} \Pi_1^P(\hat{m}^2) + \Pi_2^P(\hat{m}^2) &= (\hat{m}^2 - m_0^2)[V_1^P(\hat{m}^2) + V_2^P(\hat{m}^2)] \\ &\quad + (\hat{m}^2 - m_0^2)^2 [B_1^P(\hat{m}^2) + B_2^P(\hat{m}^2)] \\ &\quad + R_2^P(\hat{m}^2). \end{aligned} \quad (5.12)$$

We want to show that $\Pi_1^P(\hat{m}^2) + \Pi_2^P(\hat{m}^2) = O(g^6)$; substituting $\hat{m}^2 - m_0^2 = \Pi_1(\hat{m}^2) + O(g^4)$ into Eq. (5.12), and neglecting terms of $O(g^6)$ or higher, we find

$$\begin{aligned} \hat{m}^2 &= m_0^2 + \sum_{k=1}^n \Pi_k + \sum_{k=1}^{n-1} \Pi_k \sum_{m=1}^{n-1} \mathcal{V}_m^P + \left[\sum_{k=1}^{n-1} \Pi_k \right]^2 \sum_{m=1}^{n-1} \mathcal{B}_m^P + \sum_{k=1}^n \tilde{R}_k^P \\ &= m^2 + \sum_{k=1}^n \sum_{\ell=1}^k \Pi_\ell \mathcal{V}_{k-\ell}^P + \sum_{k=1}^n \sum_{j=1}^k \sum_{\ell=1}^j \Pi_\ell \Pi_{j-\ell} \mathcal{B}_{k-j}^P + \sum_{k=1}^n \tilde{R}_k^P \\ &= m^2 + \sum_{k=1}^n \left(\tilde{R}_k^P + \sum_{\ell=1}^k \Pi_\ell \mathcal{V}_{k-\ell}^P + \sum_{j=1}^k \sum_{\ell=1}^j \Pi_\ell \Pi_{j-\ell} \mathcal{B}_{k-j}^P \right). \end{aligned} \quad (5.18)$$

It is a matter of careful counting to convince oneself that each term of the series in the right-hand side (RHS) of the last Eq. (5.18) vanishes, i.e.,

$$\tilde{R}_k^P + \sum_{\ell=1}^k \Pi_\ell \mathcal{V}_{k-\ell}^P + \sum_{j=1}^k \sum_{\ell=1}^j \Pi_\ell \Pi_{j-\ell} \mathcal{B}_{k-j}^P = 0, \quad (5.19)$$

$$\begin{aligned} \Pi_1^P(\hat{m}^2) + \Pi_2^P(\hat{m}^2) &= R_2^P(\hat{m}^2) + \Pi_1(\hat{m}^2)V_1^P(\hat{m}^2) + O(g^6) \\ &= 0 + O(g^6). \end{aligned} \quad (5.13)$$

In the final step we have used Eq. (4.2) at $q^2 = \hat{m}^2$: i.e.,

$$\begin{aligned} R_2^P(\hat{m}^2) &= -\Pi_1(\hat{m}^2)V_1^P(\hat{m}^2) - \frac{3}{4}(\hat{m}^2 - m_0^2)V_1^P(\hat{m}^2) \\ &\quad \times V_1^P(\hat{m}^2) \\ &= -\Pi_1(\hat{m}^2)V_1^P(\hat{m}^2) + O(g^6). \end{aligned} \quad (5.14)$$

The generalization of the previous proof to an arbitrary loop order n in perturbation theory proceeds by induction. First of all, to simplify things we will work in the Feynman gauge. In that case, the general form of the R^P terms becomes

$$R_n^P = (q^2 - m_0^2)v_n^P + (q^2 - m_0^2)^2 b_n^P + \tilde{R}_n^P, \quad (5.15)$$

where \tilde{R}_n^P is the part of R_n^P which is of $O(g^{2n})$ at $q^2 = m_0^2$, whereas the rest is $O(g^{2(n+1)})$. For example, from R_2^P of Eq. (4.2), or equivalently Eq. (5.14), we have that $\tilde{R}_2^P(q) = -\Pi_1(q)V_1^P(q)$. Finally, we define \mathcal{V}_n^P and \mathcal{B}_n^P as

$$\begin{aligned} \mathcal{V}_n^P &= V_n^P + v_n^P, \\ \mathcal{B}_n^P &= B_n^P + b_n^P. \end{aligned} \quad (5.16)$$

Let us now assume that $\hat{m}^2 = m^2$, up to order $n-1$, i.e., $C_k = \hat{C}_k$, for every $k \leq n-1$. The expression for \hat{m}^2 to order n is

$$\begin{aligned} \hat{m}^2 &= m_0^2 + \sum_{k=1}^n \Pi_k + (\hat{m}^2 - m_0^2) \sum_{k=1}^n \mathcal{V}_k^P \\ &\quad + (\hat{m}^2 - m_0^2)^2 \sum_{k=1}^n \mathcal{B}_k^P + \sum_{k=1}^n \tilde{R}_k^P. \end{aligned} \quad (5.17)$$

Using the fact that $\hat{m}^2 - m_0^2 = \sum_{k=1}^{n-1} \Pi_k + O(g^{2n})$ (from the previous order), and that, as before, both $(\hat{m}^2 - m_0^2)\mathcal{V}_n^P$ and $(\hat{m}^2 - m_0^2)^2 \mathcal{B}_n^P$ are of $O(g^{2n+2})$ and higher, Eq. (5.17) becomes

which means that to order n , $\hat{m}^2 = m^2$, or equivalently, $C_n = \hat{C}_n$, for every n . In Appendix A, we present a proof of Eq. (5.19). It is interesting to see that it is precisely the leftover contributions we obtain when we convert conventional strings into GI strings, which enforce the equality between the conventional and PT poles.

VI. THE CASE OF THE UNSTABLE PARTICLE

We now proceed to the case of an unstable particle; we want to show that both the mass and the width remain unshifted in the context of the PT. We will adopt the definitions and methodology introduced by Sirlin [8]. Calling $s = q^2$, the pole position \bar{s} is defined as the solution of the equation

$$\bar{s} = m_0^2 + \Pi(\bar{s}). \quad (6.1)$$

We adopt the following definition of mass m and width Γ in terms of \bar{s} :

$$\bar{s} = m^2 - im\Gamma. \quad (6.2)$$

Similarly, in the context of the PT we define the pole position $\hat{s} = \hat{m}^2 - i\hat{m}\hat{\Gamma}$ as the solution of

$$\hat{s} = m_0^2 + \hat{\Pi}(\hat{s}). \quad (6.3)$$

We want to show that $\bar{s} = \hat{s}$ —or equivalently, $m = \hat{m}$ and $\Gamma = \hat{\Gamma}$ —to every order in perturbation theory. Since both Γ and $\hat{\Gamma}$ are of $O(g^2)$, at one loop we have just the result of the previous section, i.e., $m = \hat{m}$, for $n = 1$. Going to the next order, we expand Eqs. (6.1) and (6.3) up to terms of $O(g^4)$,

$$\bar{s} = m_0^2 + \Pi(m^2) - \Pi'(m^2)im\Gamma \quad (6.4)$$

and

$$\hat{s} = m_0^2 + \hat{\Pi}(\hat{m}^2) - \hat{\Pi}'(\hat{m}^2)i\hat{m}\hat{\Gamma}, \quad (6.5)$$

where $\Pi'(m^2) \equiv d\Pi(q^2)/dq^2|_{q^2=m^2}$. Separating real and imaginary parts (we omit the arguments m^2 and \hat{m}^2 , respectively) we have

$$m^2 = m_0^2 + \text{Re}\Pi + m\Gamma\text{Im}\Pi', \quad (6.6)$$

$$\hat{m}^2 = m_0^2 + \text{Re}\hat{\Pi} + \hat{m}\hat{\Gamma}\text{Im}\hat{\Pi}', \quad (6.7)$$

for the real parts, and

$$m\Gamma = -\text{Im}\Pi + m\Gamma\text{Re}\Pi', \quad (6.8)$$

$$\hat{m}\hat{\Gamma} = -\text{Im}\hat{\Pi} + \hat{m}\hat{\Gamma}\text{Re}\hat{\Pi}', \quad (6.9)$$

for the imaginary parts. Let us write \hat{m}^2 and $\hat{m}\hat{\Gamma}$ as follows:

$$\hat{m}^2 = m^2 + \epsilon_1, \quad (6.10)$$

$$\hat{m}\hat{\Gamma} = m\Gamma + \epsilon_2, \quad (6.11)$$

where

$$\epsilon_1 = \text{Re}\Pi^P + \hat{m}\hat{\Gamma}\text{Im}\Pi^{P'}, \quad (6.12)$$

$$\epsilon_2 = -\text{Im}\Pi^P + \hat{m}\hat{\Gamma}\text{Re}\Pi^{P'}. \quad (6.13)$$

In Eqs. (6.12) and (6.13), Π^P is the total pinch contribution to order g^4 , i.e., $\Pi^P = \Pi_1^P + \Pi_2^P$, with the general form given in Eq. (5.12). We now want to show that both ϵ_1 and ϵ_2 are of $O(g^6)$. Using again Eq. (5.12) we have that

$$\text{Re}\Pi^P = \text{Re}\Pi_1\text{Re}V_1^P + \text{Re}R_2 + O(g^6) \quad (6.14)$$

and

$$\begin{aligned} \hat{m}\hat{\Gamma}\text{Im}\Pi^{P'} &= [\text{Im}V_1^P + O(g^4)][-\text{Im}\Pi_1 + O(g^4)] \\ &= -\text{Im}V_1^P\text{Im}\Pi_1 + O(g^6). \end{aligned} \quad (6.15)$$

Therefore, up to terms of $O(g^6)$,

$$\begin{aligned} \epsilon_1 &= \text{Re}R_2^P + \text{Re}V_1^P\text{Re}\Pi_1 - \text{Im}V_1^P\text{Im}\Pi_1 \\ &= \text{Re}(R_2^P + \Pi_1V_1^P) \\ &= 0, \end{aligned} \quad (6.16)$$

where we used Eq. (5.14). Similarly, using the fact that, to $O(g^4)$,

$$\begin{aligned} \text{Im}\Pi^P &= \text{Im}R_2^P + \text{Im}\{(\hat{m}^2 - m_0^2)V_1^P + O(g^6)\} \\ &= \text{Im}R_2^P + \text{Im}\{V_1^P\text{Re}\Pi_1 + O(g^6)\} \\ &= \text{Im}R_2^P + \text{Re}\Pi_1\text{Im}V_1^P \end{aligned} \quad (6.17)$$

and

$$\hat{m}\hat{\Gamma}\text{Re}\Pi^{P'} = -\text{Re}V_1^P\text{Im}\Pi_1 + O(g^6) \quad (6.18)$$

we have

$$\begin{aligned} \epsilon_2 &= -\text{Im}R_2^P - \text{Re}\Pi_1\text{Im}V_1^P - \text{Re}V_1^P\text{Im}\Pi_1 \\ &= -\text{Im}(R_2^P + \Pi_1V_1^P) \\ &= 0, \end{aligned} \quad (6.19)$$

where again Eq. (4.2) was used.

It is straightforward to generalize this result to an arbitrary order n in perturbation theory. One should simply notice that the formula of Eq. (4.2) and its generalization to higher orders given by Eq. (5.19) is crucial to obtain a general proof. In particular, we have seen in Sec. III that the extension of the PT to higher orders has given rise to new PT terms, R_n^P , which guarantee that the position of the pole remains unchanged.

VII. UNITARITY AND RELATED PROPERTIES

In this section, we will analyze issues of unitarity pertinent to a consistent S -matrix perturbation theory involving unstable particles. In particular, we will mainly focus on the optical theorem, which is a direct consequence of the unitarity of the S matrix, and prescribes the form of the perturbative expansion for the transition operator T .

The T -matrix element of a reaction $i \rightarrow f$ is defined via the relation

$$\langle f|S|i\rangle = \delta_{fi} + i(2\pi)^4\delta^{(4)}(P_f - P_i)\langle f|T|i\rangle, \quad (7.1)$$

where P_i (P_f) is the sum of all initial (final) momenta of the $|i\rangle$ ($|f\rangle$) state. Furthermore, imposing the unitarity relation $S^\dagger S = 1$ leads to the optical theorem

$$\begin{aligned} \langle f|T|i\rangle - \langle i|T|f\rangle^* \\ = i \sum_{i'} (2\pi)^4\delta^{(4)}(P_{i'} - P_i)\langle i'|T|f\rangle^*\langle i'|T|i\rangle. \end{aligned} \quad (7.2)$$

In Eq. (7.2), the sum $\sum_{i'}$ should be understood to be over the whole phase space and spins of all possible on-shell intermediate particles i' . A corollary of this theorem is obtained if $i = f$. In this particular case, we have

$$\text{Im}\langle i|T|i\rangle = \frac{1}{2} \sum_f (2\pi)^4 \delta^{(4)}(P_f - P_i) |\langle f|T|i\rangle|^2. \quad (7.3)$$

In the conventional S matrix theory with stable particles, Eqs. (7.2) and (7.3) hold also perturbatively. To be precise, if one expands the transition operator in power series of the coupling constants, say g , as $T = T^{(1)} + T^{(2)} + \dots + T^{(n)} + \dots$, in a given order n one has

$$T_{fi}^{(n)} - T_{if}^{(n)*} = i \sum_{i'} (2\pi)^4 \delta^{(4)}(P_{i'} - P_i) \sum_{k=1}^{n-1} T_{i'f}^{(k)*} T_{ii'}^{(n-k)}. \quad (7.4)$$

In a scalar model containing an unstable particle, Veltman showed [4] that unitarity can be preserved by suitably modifying the S -matrix perturbation theory, in which unstable particles should always appear as intermediate states. Obviously, the S -matrix perturbation expansion arising from the truncation of the unstable particles as asymptotic states should be reformulated accordingly. A convincing example of how the PT algorithm gives rise to amplitudes which, in addition to being GI also respect unitarity, is the calculation of the magnetic dipole moment μ_W and the electric quadruple Q_W for the W boson [22]. Such quantities are of particular interest in view of the upcoming experiments of the type $e^+e^- \rightarrow W^+W^-$ [35] that will be studied at the CERN Large Electron Positron (LEP 2) collider, which is planned to operate at a center of mass system (c.m.s.) energy $s = 200$ GeV.

In order to understand under what conditions an expansion based on resummed propagators can respect the unitarity relation of Eq. (7.3), let us first consider the toy model of Ref. [4]. This model is a superrenormalizable ϕ^3 -scalar theory, which contains a light scalar, ϕ , and a heavy one, Φ , having a mass $M_\Phi > 2M_\phi$. In order to provide a decay mode for the heavy scalar into two ϕ 's, one introduces the interaction term in the Lagrangian

$$\mathcal{L}_{\text{int}} = \frac{\lambda}{2} \phi^2(x) \Phi(x), \quad (7.5)$$

where λ is a nonzero coupling constant. For concreteness, we consider the reaction $\phi\phi \rightarrow \phi\phi$ at c.m.s. energies $s \simeq M_\Phi^2$. This process proceeds via three graphs; one resonant s -channel graph, and two nonresonant t and u graphs. After performing a Dyson summation for the s -, t -, and u -channel propagators, we arrive at the following expression for the transition amplitude:

$$T(s, t, u) = -\lambda^2 \left(\frac{1}{s - M_\Phi^2 + \text{Re}\Pi_\Phi(s) + i\text{Im}\Pi_\Phi(s)} + \frac{1}{t - M_\Phi^2 + \Pi_\Phi(t)} + \frac{1}{u - M_\Phi^2 + \Pi_\Phi(u)} \right), \quad (7.6)$$

where $\Pi_\Phi(q^2)$ is the irreducible two-point function of the $\Phi\Phi$ self-energy at the one loop order. It is easy to verify from Eq. (7.6), that the amplitude $T(s, t, u)$ is endowed with the analyticity property of crossing symmetry. In other words, the various processes can be obtained by appropriately interchanging the Mandelstam variables s , t , and u ; obviously $T(s, t, u) = T(t, s, u) = \dots$. These crossing properties can be naturally implemented, when the resummed self-energies appearing in Eq. (7.6) are momentum dependent. When crossing is applied in such a case, the unphysical absorptive parts are killed by the kinematic θ functions, whereas the new physical absorptive contributions, which emerge after crossing, will regulate the resulting resonant channels. This feature persists even if vertex and box graphs are included. A qualitatively similar behavior is expected in gauge theories; since the resummed self-energy derived from the PT depends on q^2 , we conclude that our PT approach to gauge theories with unstable particles respects the crossing symmetry.

We will now discuss the main reason which clearly advocates for a q^2 -dependent regulator, rather than a constant one. If we consider the LHS of Eq. (7.3), we have, for the process $\phi\phi \rightarrow \phi\phi$,

$$\text{Im}T(s, t, u) = \frac{\lambda^2 \text{Im}\Pi_\Phi(s)}{[s - M_\Phi^2 + \text{Re}\Pi_\Phi(s)]^2 + [\text{Im}\Pi_\Phi(s)]^2}, \quad (7.7)$$

which is related to the amplitude squared of the resonant s -exchange graph, say T_s . In fact, one finds that

$$\text{Im}T(s, t, u) = \frac{1}{2} \int dX_{\text{LIPS}} |T_s(s)|^2, \quad (7.8)$$

where X_{LIPS} stands for the Lorentz-invariant phase space for the two on-shell ϕ particles. Equation (7.8) is consistent with Eq. (7.4) in a perturbative sense. At this point it is important to notice that the unitarity relation of Eq. (7.8) is *only* valid when the resummation involves an s -dependent two-point function and width for the unstable scalar Φ . If a constant width for Φ had been considered instead, unitarity would have been violated through Eq. (7.8), when $s \neq M_\Phi^2$. It is therefore evident that the regulator of a resummed propagator should be s dependent in this scalar theory. The above problem is expected to appear if one attempts to use a constant pole expansion in the context of a gauge field theory. Indeed, there is no fundamental reason to believe that one could consistently describe gauge theories using a resummation procedure which is not well justified even for scalar theories. On the other hand, the reordering of Feynman graphs via the PT and the resummation of the momen-

tum dependent PT self-energies provides a GI solution to the problem at hand, while, at the same time, does not introduce residual unitarity-violating terms in the resonant matrix element.

In what follows we will analyze some crucial aspects of the PT algorithm in relation to the unitarity, and underline the analogies between the PT results in gauge theories and some known facts from the ϕ^3 scalar theory. In the ϕ^3 model, the transition amplitude of Eq. (7.6) exhibits a clear separation of the dependence on the Mandelstam variables s , t , and u . In this way, resummation can be applied to each channel independently. Because of this property, $T(s, t, u)$ displays the correct high-energy unitarity behavior, and vanishes as $s, t \rightarrow \infty$. In gauge theories, this is generally not the case. For example, consider the process $l^- \bar{\nu}_l \rightarrow W^- H$ shown in Fig. 6, where the charged lepton (l) is massive. In the Born approximation, there exist two graphs: an s - and t -mediated graph in the unitary gauge [see, also, Figs. 6(a) and 6(c)]. Taking the infinite limit of s and t for the s -channel graph, one can verify that this amplitude alone does not vanish. On the other hand, the total matrix element tends to zero in the high-energy unitarity limit. Evidently, the t -exchange graph contains terms, which, when properly taken into account, conspire in such a way so as to give the correct high-energy unitarity limit. The PT algorithm accomplishes, via the decomposition given in Eq. (2.8), the same clear kinematic separation one knows from the scalar theory.

The above discussion becomes more transparent if one employs the Ward identities which relate the Feynman

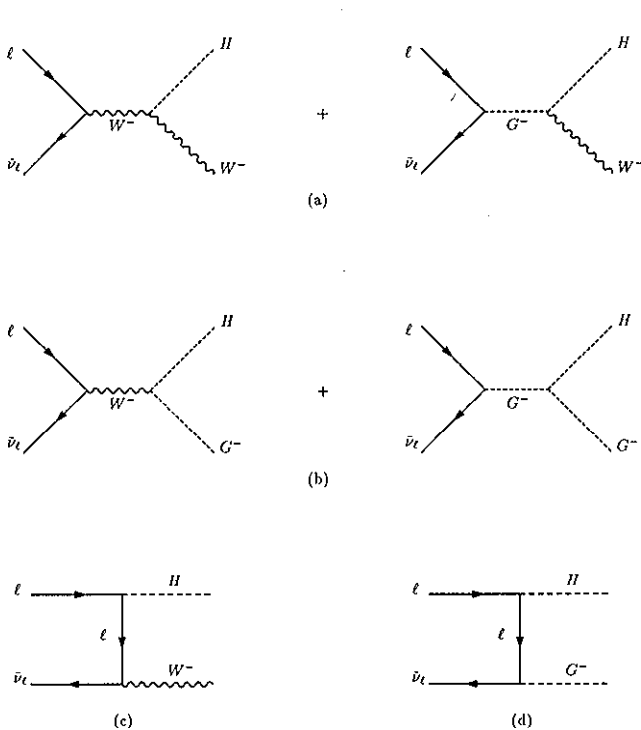

FIG. 6. The process $l \bar{\nu}_l \rightarrow H W^-$ in an arbitrary R_t gauge.

graphs of Fig. 6(a) to those of Fig. 6(b), and the diagram of Fig. 6(c) to that of Fig. 6(d). For the process $l \bar{\nu}_l \rightarrow W^- (p_-) H(p_H)$, we have in an arbitrary ξ gauge

$$\frac{p_-^\mu}{M_W} T_{(a)\mu}^{(\xi)} = T_{(b)}^{(\xi)} - \frac{g_w}{2M_W} \Lambda_0, \quad (7.9)$$

$$\frac{p_-^\mu}{M_W} T_{(c)\mu}^{(\xi)} = T_{(d)}^{(\xi)} + \frac{g_w}{2M_W} \Lambda_0. \quad (7.10)$$

In the high-energy limit where $p_- \rightarrow \infty$, the polarization vector, $\epsilon_L^\mu(p_-)$, of the longitudinal W boson approaches to p_-^μ/M_W . In the Feynman gauge, the amplitudes $T_{(d)}$ and $T_{(b)}$ vanish in the limit $s, t \rightarrow \infty$. In this limit, it is easy to see that the remaining constant term in Eq. (7.9) is responsible for the bad high-energy behavior, and can only be cancelled if a corresponding term coming from Eq. (7.10) is added. It turns out that, when loop corrections are considered, this latter term is furnished by the relevant PT part thus leading to a proper s -dependent propagator [20].

An issue related to the discussion of unitarity is whether the PT self-energy which regularizes the singular propagator contains any unphysical absorptive parts. From Eq. (7.4), one has to show that the propagatorlike part \hat{T}_1 of a reaction should contain imaginary parts associated with physical Landau singularities only, whereas the unphysical poles related to Goldstone bosons and ghosts must vanish in the loop. Although the PT algorithm produces a GI result for \hat{T}_1 , there would still have been a problem if this procedure had introduced some fixed unphysical poles. A qualitative argument suggesting that this is not the case, is that the PT results can

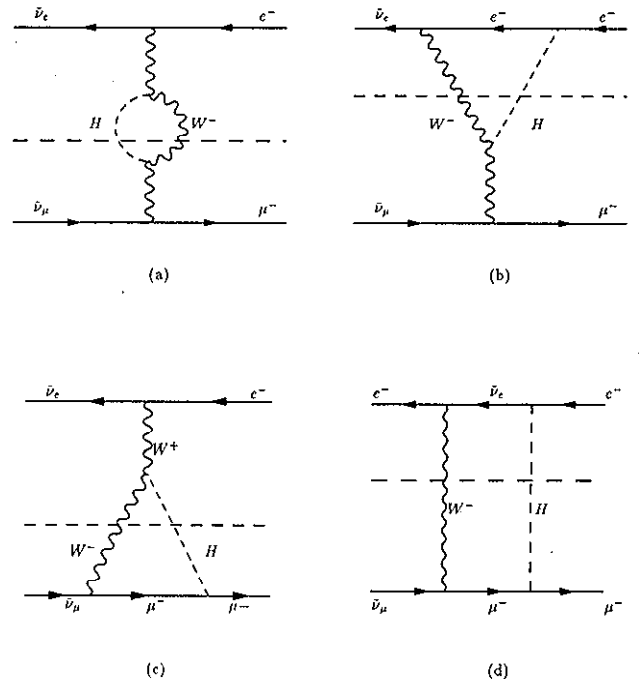

FIG. 7. The one loop absorptive graphs of the reaction $e^- \bar{\nu}_e \rightarrow \mu^- \bar{\nu}_\mu$ involving the on-shell intermediate bosons W^- and H (the arrow of time shows downwards). Feynman lines with Goldstone bosons are not displayed.

be obtained equally well by working *directly* in the unitary gauge [21], where only physical Landau poles are present. We will also demonstrate this fact by an explicit calculation of the $\text{Im}\widehat{T}_1$ of the process $e\bar{\nu}_e \rightarrow \mu\bar{\nu}_\mu$ at the one loop electroweak order. We will assume that only the W and H particles can come kinematically on

the mass shell, as shown in Fig. 7. In what follows, we omit the common integration measure of the loop, $1/[2(2\pi)^4] \int d^4p_- d^4p_H \delta^{(4)}(p_H + p_- - p_e - p_\nu)$. Then, the absorptive amplitude, $\text{Im}M$, for the aforementioned process may be conveniently written as (suppressing contraction over Lorentz indices)

$$\begin{aligned} \text{Im}M = \tilde{\Delta}_{0H}(p_H) & \left[T_{(a)}^{1(\xi)} \tilde{\Delta}_0^{(\xi)}(p_-) T_{(a)}^{2(\xi)} + T_{(b)}^{1(\xi)} \tilde{D}_0^{(\xi)}(p_-) T_{(b)}^{2(\xi)} + T_{(c)}^{1(\xi)} \tilde{\Delta}_0^{(\xi)}(p_-) T_{(a)}^{2(\xi)} \right. \\ & + T_{(a)}^{1(\xi)} \tilde{\Delta}_0^{(\xi)}(p_-) T_{(c)}^{2(\xi)} + T_{(d)}^{1(\xi)} \tilde{D}_0^{(\xi)}(p_-) T_{(b)}^{2(\xi)} + T_{(b)}^{1(\xi)} \tilde{D}_0^{(\xi)}(p_-) T_{(d)}^{2(\xi)} \\ & \left. + T_{(c)}^{1(\xi)} \tilde{\Delta}_0^{(\xi)}(p_-) T_{(c)}^{2(\xi)} + T_{(d)}^{1(\xi)} \tilde{D}_0^{(\xi)}(p_-) T_{(d)}^{2(\xi)} \right], \end{aligned} \quad (7.11)$$

where T^1 (T^2) denotes the electron (muon) mediated amplitude present in Fig. 7, and the tilde acting on the tree-level propagators simply projects out the corresponding absorptive parts, as these are effectively obtained after applying the Cutkosky rules. More explicitly, we have

$$\tilde{\Delta}_{0H}(p_H) = 2\pi i \delta_+(p_H^2 - M_H^2), \quad (7.12)$$

$$\tilde{D}_0^{(\xi)}(p) = 2\pi i \delta_+(p^2 - \xi M_W^2), \quad (7.13)$$

$$\begin{aligned} \tilde{\Delta}_{0\mu\nu}^{(\xi)}(p) & = 2\pi i \left[\left(-g_{\mu\nu} + \frac{p_\mu p_\nu}{M_W^2} \right) \delta_+(p^2 - M_W^2) \right. \\ & \quad \left. - \frac{p_\mu p_\nu}{M_W^2} \delta_+(p^2 - \xi M_W^2) \right] \\ & = \tilde{U}_{\mu\nu}(p) - \frac{p_\mu p_\nu}{M_W^2} \tilde{D}_0^{(\xi)}(p), \end{aligned} \quad (7.14)$$

with $\delta_+(p^2 - M^2) = \delta(p^2 - M^2)\theta(p^0)$. After identifying the PT piece $[T_P^i = g_w \Lambda_0^{(i)}/2M_W$, with $i = 1(:e), 2(:\mu)]$, which is obtained from Eq. (7.10) each time the $p^\mu p^\nu$ -dependent part of $\tilde{\Delta}_{0\mu\nu}^{(\xi)}$ gets contracted with $T_{(c)}^{i(\xi)}$, we find that the imaginary propagatorlike part is

$$\begin{aligned} \text{Im}\widehat{T}_1 = \tilde{\Delta}_{0H}(p_H) & \left\{ T_{(a)}^{1(\xi)} \tilde{\Delta}_0^{(\xi)}(p_-) T_{(a)}^{2(\xi)} + T_{(b)}^{1(\xi)} \tilde{D}_0^{(\xi)}(p_-) T_{(b)}^{2(\xi)} + (2\pi i) \left[T_P^1 \frac{p_-^\nu}{M_W} T_{(a)\nu}^{2(\xi)} + T_{(a)\lambda}^{1(\xi)} \frac{p_-^\lambda}{M_W} T_P^2 + T_P^1 T_P^2 \right] \right. \\ & \quad \left. \times [\delta_+(p_-^2 - M_W^2) - \delta_+(p_-^2 - \xi M_W^2)] \right\} \\ & = \tilde{\Delta}_{0H}(p_H) \left\{ T_{(a)}^{1(\infty)} \tilde{U}(p_-) T_{(a)}^{2(\infty)} + (2\pi i) \left[T_P^1 \frac{p_-^\nu}{M_W} T_{(a)\nu}^{2(\infty)} + T_{(a)\lambda}^{1(\infty)} \frac{p_-^\lambda}{M_W} T_P^2 + T_P^1 T_P^2 \right] \delta_+(p_-^2 - M_W^2) \right\} + \delta\widehat{T}_1. \end{aligned} \quad (7.15)$$

In the last step of Eq. (7.15), we have separated contributions originating from the physical poles at $p_H^2 = M_H^2$ and $p_-^2 = M_W^2$ from those that occur at $p_-^2 = \xi M_W^2$ and are included in $\delta\widehat{T}_1$, where

$$\begin{aligned} \delta\widehat{T}_1 = & \bar{\Delta}_{0H}(p_H)\bar{D}_0^{(\xi)}(p_-) \left[-T_{(a)\lambda}^{1(\xi)} \frac{p_-^\lambda p_-^\nu}{M_W^2} T_{(a)\nu}^{2(\xi)} \right. \\ & + T_{(b)}^{1(\xi)} T_{(b)}^{2(\xi)} - T_P^1 \frac{p_-^\nu}{M_W} T_{(a)\nu}^{2(\xi)} \\ & \left. - T_{(a)\lambda}^{1(\xi)} \frac{p_-^\lambda}{M_W} T_P^2 - T_P^1 T_P^2 \right]. \end{aligned} \quad (7.16)$$

Obviously, the imaginary parts coming from the physical Landau singularities are manifestly GI, whereas the term $\delta\widehat{T}_1$ not only should be GI because of the PT reordering, but it should vanish identically. With the help of Eq. (7.9), it is a matter of simple algebra to show that indeed $\delta\widehat{T}_1 = 0$.

It is therefore important to emphasize the conclusions of this section. The PT algorithm can effectively disentangle the different kinematic dependences on the Mandelstam variables s and t via the decomposition given in Eq. (2.8), when radiative corrections are considered. Furthermore, this algorithm yields a proper q^2 -dependent propagator displaying the desired unitarity behavior in the high-energy limit. The PT method not only produces GI analytic results but also gives rise to a well-defined self-energy, in which only physical absorptive parts are present, while unphysical Landau singularities originating from ghosts and Goldstone bosons do not survive. This latter property is particularly advantageous, since we wish to resum the q^2 -dependent PT self-energy in order to unitarize the singular resonant amplitude, and, at the same time, avoid the presence of unphysical residual absorptive phases, which could be generated if a constant pole expansion had been used instead.

VIII. THE PROCESS $\gamma e^- \rightarrow \mu^- \bar{\nu}_\mu \nu_e$

We will study the process $\gamma e^- \rightarrow \mu^- \bar{\nu}_\mu \nu_e$, in which two gauge W bosons are involved. This process is of potential interest at the LEP2. Furthermore, the collider Tevatron at Fermilab offers the possibility to study the scattering process $qq' \rightarrow \gamma \mu^- \bar{\nu}_\mu$ [13].

In the Born approximation, the process $\gamma e^- \rightarrow \mu^- \bar{\nu}_\mu \nu_e$ consists of three Feynman graphs shown in Fig. 8, with the gauge bosons in the unitary gauge. The transition amplitude then reads

$$T(\gamma e^- \rightarrow \mu^- \bar{\nu}_\mu \nu_e) = \varepsilon_\gamma^\mu(q) T_{0\mu}, \quad (8.1)$$

with

$$\begin{aligned} T_{0\mu} = & \Gamma_{0\rho} U_W^{\rho\nu}(p_-) \Gamma_{0\mu\nu\lambda}^{\gamma W^- W^+}(q, p_-, p_+) U_W^{\lambda\sigma}(p_+) \Gamma_{0\sigma} \\ & + \Gamma_{0\rho} S_0^{(e)} \Gamma_{0\mu}^{\gamma} U_W^{\rho\nu}(p_+) \Gamma_{0\nu} + \Gamma_{0\rho} U_W^{\rho\nu}(p_-) \\ & \times \Gamma_{0\mu}^{\gamma} S_0^{(\mu)} \Gamma_{0\nu}. \end{aligned} \quad (8.2)$$

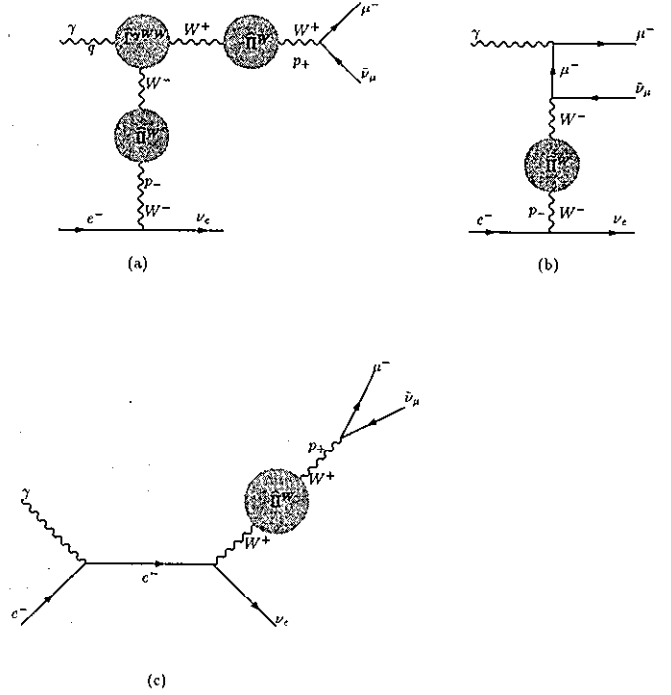

FIG. 8. The process $e^- \gamma \rightarrow \mu^- \bar{\nu}_\mu \nu_e$. The bubbles denote PT self-energies and three-point functions. Goldstone boson lines are not shown.

In Eq. (8.2), $S_0^{(f)} = (\not{p} - m_f)^{-1}$ denotes the free f -fermion propagator, $\Gamma_0^{\gamma W^- W^+}$ ($\Gamma_{0\mu}^\gamma$) is the tree-level $\gamma W W$ ($l^- l^+ \gamma$) coupling, and p_- (p_+) is the momentum of the W^- (W^+) boson flowing into the $\gamma W^- W^+$ vertex. The form of the amplitude given in (8.1) is gauge-invariant, in the sense that it does not depend on the gauge-fixing procedure nor the gauge-fixing parameter chosen. In the R_ξ gauges, for example, additional graphs with Goldstone bosons must be included, but at the end, the expression of (8.1) will emerge again. In addition, since the action of the photonic momentum on the tree-level $\gamma W W$ vertex triggers the elementary Ward identity

$$\frac{1}{e} q^\mu \Gamma_{0\mu\nu\lambda}^{\gamma W^- W^+} = U_{W\nu\lambda}^{-1}(p_+) - U_{W\nu\lambda}^{-1}(p_-), \quad (8.3)$$

the electromagnetic gauge-invariance of the tree-level amplitude is evident, i.e., $q^\mu T_{0\mu} = 0$. In Eq. (8.3), $U_{W\mu\nu}^{-1}$ is the inverse free propagator, of the W boson in the unitary gauge. In general, the inverse free propagator of a vector boson, V , including massless gauge bosons, such as photons and gluons, may be obtained from Eq. (2.5) in the same gauge. Its explicit form is given by

$$U_{V\mu\nu}^{-1}(q) = t_{\mu\nu}(q)(q^2 - M_V^2) + \ell_{\mu\nu}(q)M_V^2. \quad (8.4)$$

However, since the $T_{0\mu}$ of (8.2) exhibits a physical pole at $p_+^2 = M_W^2$, the use of a resummed propagator is needed. As we have discussed in Sec. II, the naive form of a BW propagator for the singular amplitudes violates $U(1)_{em}$ and R_ξ gauge-invariance. On the other hand, the PT method used to reorder the Feynman graphs, restores

both the $U(1)_{em}$ and the R_ξ invariance of the amplitude, which are present at the tree level.

To see that, let us concentrate on the part $\widehat{T}_{1\mu}$ of the amplitude, shown in Fig. 8, which contains the trilinear γWW vertex. Applying the PT, and then resumming the PT self-energies following a procedure exactly analogous to the one described in Sec. II, we arrive at the resonant transition amplitude (suppressing all the contracted Lorentz indices except of the photonic one):

$$\widehat{T}_{1\mu} = \Gamma_0 \widehat{\Delta}_W (\Gamma_{0\mu}^{\gamma W^- W^+} + \widehat{\Gamma}_\mu^{\gamma W^- W^+}) \widehat{\Delta}_W \Gamma_0 + \Gamma_0 S_0^{(e)} \Gamma_{0\mu}^\gamma \widehat{\Delta}_W \Gamma_0 + \Gamma_0 \widehat{\Delta}_W \Gamma_{0\mu}^\gamma S_0^{(\mu)} \Gamma_0. \quad (8.5)$$

The PT procedure renders all hatted quantities in the above expression independent of the gauge-fixing parameter ξ ; $\widehat{\Delta}_W$ is given in Eq. (2.18). The final ingredient which enforces the full R_ξ invariance of the resonant amplitude $\widehat{T}_{1\mu}$, and allows it to be cast in the form of Eq. (8.5), is a number of Ward identities, satisfied by the PT vertices. These identities can be summarized as (all momenta flow into the vertex, i.e., $q + p_- + p_+ = 0$)

$$\frac{1}{e} q^\mu \widehat{\Gamma}_{\mu\nu\lambda}^{\gamma W^- W^+} = \widehat{\Pi}_{\nu\lambda}^W(p_-) - \widehat{\Pi}_{\nu\lambda}^W(p_+), \quad (8.6)$$

$$\frac{1}{e} q^\mu \widehat{\Gamma}_{\mu\nu}^{\gamma G^- W^+} = \frac{1}{e} q^\mu \widehat{\Gamma}_{\mu\nu}^{\gamma W^- G^+} = \widehat{\Theta}_\nu(p_-) + \widehat{\Theta}_\nu(p_+), \quad (8.7)$$

$$\frac{1}{e} q^\mu \widehat{\Gamma}_\mu^{\gamma G^- G^+} = \widehat{\Omega}(p_-) - \widehat{\Omega}(p_+), \quad (8.8)$$

$$\begin{aligned} & \frac{1}{e} [p_-^\nu \widehat{\Gamma}_{\mu\nu\lambda}^{\gamma W^- W^+} - M_W \widehat{\Gamma}_{\mu\lambda}^{\gamma G^- W^+}] \\ & = \widehat{\Pi}_{\mu\lambda}^W(p_+) - \widehat{\Pi}_{\mu\lambda}^\gamma(q) - \frac{c_w}{s_w} \widehat{\Pi}_{\mu\lambda}^{\gamma Z}(q), \end{aligned} \quad (8.9)$$

$$\begin{aligned} & \frac{1}{e} [p_+^\lambda \widehat{\Gamma}_{\mu\nu\lambda}^{\gamma W^- W^+} + M_W \widehat{\Gamma}_{\mu\nu}^{\gamma W^- G^+}] \\ & = -\widehat{\Pi}_{\mu\nu}^W(p_-) + \widehat{\Pi}_{\mu\nu}^\gamma(q) + \frac{c_w}{s_w} \widehat{\Pi}_{\mu\nu}^{\gamma Z}(q), \end{aligned} \quad (8.10)$$

$$\frac{1}{e} [p_-^\nu \widehat{\Gamma}_{\mu\nu}^{\gamma W^- G^+} - M_W \widehat{\Gamma}_\mu^{\gamma G^- G^+}] = -\widehat{\Theta}_\mu(p_+), \quad (8.11)$$

$$\frac{1}{e} [p_+^\lambda \widehat{\Gamma}_{\mu\lambda}^{\gamma G^- W^+} + M_W \widehat{\Gamma}_\mu^{\gamma G^- G^+}] = -\widehat{\Theta}_\mu(p_-), \quad (8.12)$$

$$\begin{aligned} & \frac{1}{e} [p_-^\nu p_+^\lambda \widehat{\Gamma}_{\mu\nu\lambda}^{\gamma W^- W^+} + M_W^2 \widehat{\Gamma}_\mu^{\gamma G^- G^+}] \\ & = M_W \widehat{\Theta}_\mu(p_+) - M_W \widehat{\Theta}_\mu(p_-) \\ & \quad - p_+^\lambda \left(\widehat{\Pi}_{\mu\lambda}^\gamma(q) + \frac{c_w}{s_w} \widehat{\Pi}_{\mu\lambda}^{\gamma Z}(q) \right). \end{aligned} \quad (8.13)$$

In the derivation of the above equations, we have used the fact that

$$q^\mu \widehat{\Pi}_{\mu\lambda}^\gamma(q) = 0, \quad (8.14)$$

$$q^\mu \widehat{\Pi}_{\mu\lambda}^{\gamma Z}(q) = 0, \quad (8.15)$$

which implies that $\widehat{\Pi}_{\mu\nu}^\gamma(0) = 0$ and $\widehat{\Pi}_{\mu\nu}^{\gamma Z}(0) = 0$.

The one loop PT self-energy [20] and the one loop γWW vertex [22] are, respectively, given by

$$\begin{aligned} \widehat{\Pi}_{\mu\nu}^W(p) &= \Pi_{\mu\nu}^{W(\xi=1)}(p) - 4g_w^2 U_{W\mu\nu}^{-1}(p) [s_w^2 I_{W\gamma}(p) + c_w^2 I_{WZ}(p)], \\ \widehat{\Gamma}_{\mu\nu\lambda}^{\gamma W^- W^+}(q, p_-, p_+) &= \Gamma_{\mu\nu\lambda}^{\gamma W^- W^+(\xi=1)}(q, p_-, p_+) - g_w s_w \left[U_{\gamma\mu}^{-1\alpha}(q) B_{\alpha\nu\lambda}(q, p_-, p_+) \right. \\ & \quad \left. + U_{W\nu}^{-1\alpha}(p_-) B_{\mu\alpha\lambda}^+(q, p_-, p_+) + U_{W\lambda}^{-1\alpha}(p_+) B_{\mu\nu\alpha}^-(q, p_-, p_+) \right] \\ & \quad - 2g_w^2 \Gamma_{0\mu\nu\lambda}^{\gamma W^- W^+}(q, p_-, p_+) \left[I_{WW}(q) + s_w^2 I_{W\gamma}(p_-) + s_w^2 I_{W\gamma}(p_+) \right. \\ & \quad \left. + c_w^2 I_{WZ}(p_-) + c_w^2 I_{WZ}(p_+) \right] + g_w s_w \left[g_{\mu\nu} p_{+\lambda} \mathcal{M}^-(q, p_-, p_+) \right. \\ & \quad \left. + g_{\mu\lambda} p_{-\nu} \mathcal{M}^+(q, p_-, p_+) \right], \end{aligned} \quad (8.16)$$

where $\Pi_{\mu\nu}^{W(\xi=1)}$ [36] and $\Gamma_{\mu\nu\lambda}^{\gamma W^- W^+(\xi=1)}$ [37] are the conventional one loop WW self-energy and γWW coupling, respectively, evaluated in the Feynman gauge, and the functions I_{ij} , $B_{\mu\nu\lambda}$, $B_{\mu\nu\lambda}^\pm$, and \mathcal{M}^\pm are defined in Appendix B.

If we now contract $\widehat{T}_{1\mu}$ of Eq. (8.5) with q^μ , it is elementary to verify, that by virtue of the Ward identity of Eq. (8.6), $q^\mu \widehat{T}_{1\mu} = 0$. So we conclude that the reso-

nant amplitude obtained by the PT satisfies both R_ξ and $U(1)_{em}$ invariance.

Note finally, that all PT Green's functions defined thus far satisfy QED-like Ward identities [for example, Eqs. (8.6)–(8.13)]. This feature not only enforces the R_ξ and $U(1)_{em}$ invariance, but it constitutes a sufficient condition that our approach admits multiplicative renormalization [38].

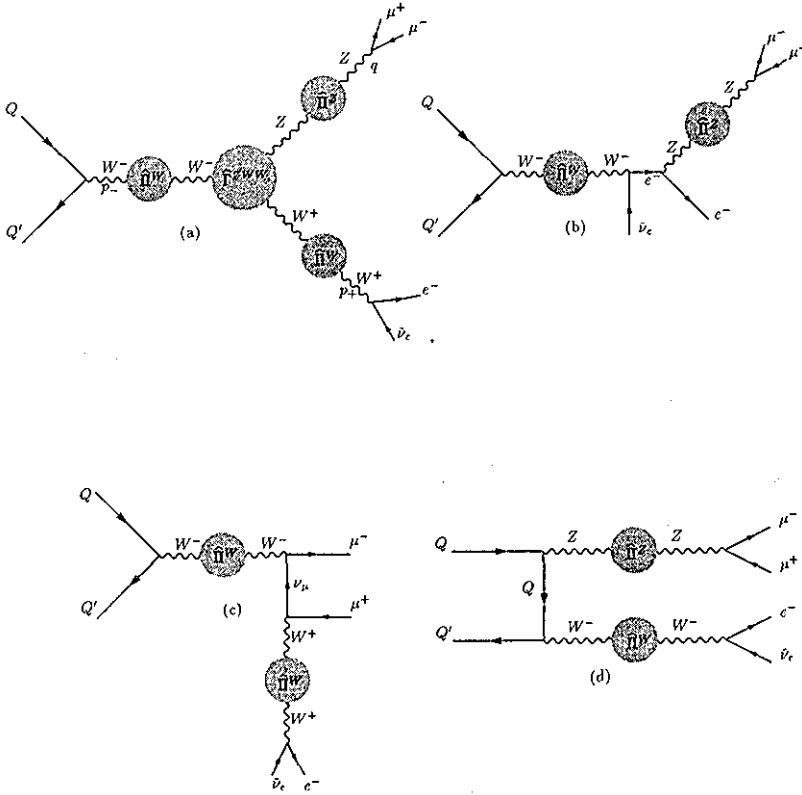

FIG. 9. The process $QQ' \rightarrow \mu^+ \mu^- e^- \bar{\nu}_e$, where $Z\gamma$ -mixing effects and other photonic contributions are not shown. Crossed Z -boson exchange graphs are also implied.

Another process that is of particular interest in testing the electroweak theory at Tevatron is $QQ' \rightarrow e^- \bar{\nu}_e \mu^- \mu^+$; there, in addition to the γWW , the ZWW coupling appears also. The phenomenological relevance of the ZWW coupling becomes important as soon as the invariant-mass cut $m(\mu^- \mu^+) \simeq M_Z$ is imposed. In a similar way,

one can analytically derive the \hat{T}_1 amplitude for this process, which is more involved due to the presence of $Z\gamma$ -mixing effects [39]. As an example, we consider the GI amplitude \hat{T}_1^Z , which, as can be seen from Fig. 9, does not contain tree-level photonic contributions. \hat{T}_1^Z can be cast into the form

$$\begin{aligned}
 \hat{T}_1^Z = & \Gamma_0 \hat{\Delta}_W(p_-) (\Gamma_0^{ZW^-W^+} + \hat{\Gamma}^{ZW^-W^+}) \hat{\Delta}_Z(q) \Gamma_0^Z \hat{\Delta}_W(p_+) \Gamma_0 \\
 & + \Gamma_0 S_0^{(Q)} \Gamma_0^Z \hat{\Delta}_Z(q) \Gamma_0^Z \hat{\Delta}_W(p_+) \Gamma_0 + \Gamma_0^Z S_0^{(Q')} \Gamma_0 \hat{\Delta}_Z(q) \Gamma_0^Z \hat{\Delta}_W(p_+) \Gamma_0 \\
 & + \Gamma_0 \hat{\Delta}_W(p_-) \Gamma_0^Z \hat{\Delta}_Z(q) \Gamma_0^Z S_0^{(e)} \Gamma_0 + \Gamma_0 \hat{\Delta}_W(p_-) \Gamma_0^Z \hat{\Delta}_Z(q) \Gamma_0 S_0^{(\nu_e)} \Gamma_0^Z \\
 & + \Gamma_0 \hat{\Delta}_W(p_-) \Gamma_0 S_0^{(\nu_\mu)} \Gamma_0 \hat{\Delta}_W(p_+) \Gamma_0,
 \end{aligned} \tag{8.18}$$

where Γ_0^Z stands for the Z coupling to fermions at the tree level. The PT Ward identities, which are necessary for maintaining gauge invariance, are listed in Appendix C. It should be noted that the inclusion of the $Z\gamma$ mixing in Eq. (8.18) proceeds in a straightforward way, since in the PT framework these additional contributions form a distinct GI subset of graphs. Indeed, both $\hat{\Pi}_{\mu\nu}^\gamma(q)$ and $\hat{\Pi}_{\mu\nu}^{Z\gamma}(q)$ are by construction *independent* of the gauge-fixing parameter, and the final gauge cancellations proceed by virtue of the transversality properties of $\hat{\Pi}_{\mu\nu}^\gamma(q)$ and $\hat{\Pi}_{\mu\nu}^{Z\gamma}(q)$, as explicitly stated in Eqs. (8.14) and (8.15). By analogy, the Higgs-mixing terms, which become significant for external heavy fermions, also form

a GI subset; possible additional refinements necessary for their proper inclusion in \hat{T}_1 will be studied elsewhere.

IX. CONCLUSIONS

We have presented a new GI approach to resonant transition amplitudes with external nonconserved currents, based on the PT method. We have explicitly demonstrated how our analytic approach bypasses the theoretical difficulties existing in the present literature, by considering the resonant processes $e^- \bar{\nu}_e \rightarrow \mu^- \bar{\nu}_\mu$ and $\gamma e^- \rightarrow \mu^- \bar{\nu}_\mu \nu_e$ in the SM, with massive external charged

leptons. In particular, it has been found that our approach defines a consistent GI perturbative expansion of the S matrix, where singular propagators are regularized by resumming PT self-energies. Through an explicit proof, particular emphasis has been put on the fact that the PT resummed propagator does not shift the complex pole position of the resonant amplitude. Furthermore, it has been demonstrated that the so-derived propagator does not give rise to fixed unphysical Landau poles. The main points of our approach can be summarized as follows.

(i) The analytic expressions derived with our approach are, by construction, *independent* of the gauge-fixing parameter, in *every* gauge-fixing scheme (R_ξ gauges, axial gauges, background field method, etc.). In addition, by virtue of the tree-level Ward identities satisfied by the PT Green's functions, the $U(1)_{\text{em}}$ invariance can be enforced, without introducing residual gauge-dependent terms of higher orders.

(ii) As can be noticed from Sec. IX and Appendix C, the two- and three-point PT functions satisfy Abelian-type Ward identities. This is a sufficient condition in order that multiplicative renormalization is admissible within our approach.

(iii) We treat, *on equal footing*, bosonic and fermionic contributions to the resummed propagator of the W , Z boson, t quark, or other unstable particle. This feature is highly desirable when confronting the predictions of extensions of the SM with data from high-energy colliders, such as the planned Large Hadron Collider (LHC) at CERN. Most noticeably, extra gauge bosons, such as the Z' , W' , Z_R predicted in $SO(10)$ or E_6 unified models [40], can have widths predominantly due to bosonic channels; the same would be true for the standard Higgs boson (H) within the minimal SM, if it turned out to be heavy. In such cases it becomes particularly apparent that prescriptions based on resumming *only* GI subsets of fermionic contributions are bound to be inadequate.

(iv) The main drawback of using an expansion of the resonant matrix element in terms of a *constant* complex pole is that this approach introduces spacelike threshold terms to all orders, whereas nonresonant corrections can remove such terms only up to a given order. These spacelike terms manifest themselves when the c.m.s. energy of the process does not coincide with the position of the resonant pole. As we showed in Sec. VII, these terms explicitly violate the unitarity of the amplitude. On the contrary, our approach avoids this kind of problem by yielding an energy-dependent complex-pole regulator. For instance, for channels below their production threshold, such residual unitarity-violating terms coming from unphysical absorptive parts have already been killed by the corresponding kinematic θ functions.

(v) Finally, our approach provides a good high-energy unitarity behavior to our amplitude, as the c.m.s. energy $s \rightarrow \infty$. In fact, far away from the resonance, the resonant amplitude tends to the usual PT amplitude, showing up the correct high-energy unitarity limit of the entire tree-level process.

Our formalism can find an immediate application in

the study of unstable particles at LEP, LEP2, and Tevatron. The exact numerical significance of the GI bosonic contributions requires a detailed analysis and is beyond the scope of the present work. However, it is possible to provide a qualitative estimate of the bosonic effects. For example, in the case of the W boson at LEP2 and Tevatron, such effects are relevant for momentum exchanges, q^2 , larger than M_W^2 . For $q^2 > M_W^2$, the improvement based on a running fermionic width [8, 13] as compared to a constant width [7, 9, 10] is of order $\Gamma_W^2/M_W^2 \sim 10^{-3}$ [14]. The numerical impact of the GI bosonic contributions are expected to be one order of magnitude less. The reason is that the dominant bosonic diagrams containing a W boson and a γ are suppressed by a factor $\sin^2 \theta_w$ relative to fermionic graphs due to the different coupling constants. In addition, an extra suppression factor comes from the fact that there is only one bosonic channel as opposed to nine fermionic ones. It is important to emphasize that the previous elementary argument becomes reliable only in the context of our formalism, where all dependence on the gauge fixing parameter has been cancelled; instead, in the conventional formulation the above counting argument could be invalidated by the presence of arbitrarily large gauge artifacts.

Although more attention has been paid to the unstable W and Z gauge particles, our considerations will also apply to the case of the heavy top quark discovered recently [41]. Our formalism is particularly suited for a systematic study of the CP properties of the top quark [5] at LHC. Our method may find important applications in the context of supersymmetric theories, especially when resonant CP effects in the production and decay of heavy gluinos and scalar quarks are studied [9]. It may also be interesting to consider our GI approach as an appealing alternative to the conventional formulation of supergravity theories in the background field gauges, where, in addition to the regular Fadeev-Popov ghosts [42], the Nielsen-Kallosh ghosts [43] may appear. Finally, our analysis could be of relevance for the study of nonperturbative or Coulomb-like phenomena, which may appear in the production of unstable particles [44], and are currently estimated by using special forms of the DS integral equation [45, 44].

ACKNOWLEDGMENTS

We wish to thank J. M. Cornwall, K. Philippides, A. Sirlin, R. Stuart, and D. Zeppenfeld for helpful discussions. This work was supported in part by the National Science Foundation Grant No. PHY-9313781.

APPENDIX A: THE STRUCTURE OF THE \tilde{R}^P TERMS

In order to understand the structure of the \tilde{R}^P , we study in detail the three-loop case. To avoid notational clutter we remove the superscript “ P ” from \mathcal{V}^P , V^P , v^P ,

\mathcal{B}^P , B^P , and b^P .

For $k = 3$, Eq. (5.19) gives

$$\tilde{R}_3 = -[\Pi_1 \mathcal{V}_2 + \Pi_2 \mathcal{V}_1], \quad (\text{A1})$$

where we used that $B_1 = \mathcal{B}_1 = 0$ in the Feynman gauge.

We now proceed to derive Eq. (A1). To that end, we first express a string with the three $\hat{\Pi}_1$ self-energies in terms of conventional strings, and the necessary pinch contributions. We have

$$\begin{aligned} \hat{L}_1 &= D_0 \hat{\Pi}_1 D_0 \hat{\Pi}_1 D_0 \hat{\Pi}_1 D_0 \\ &= D_0 [\Pi_1 + \mathcal{V}_1 D_0^{-1}] D_0 [\Pi_1 + \mathcal{V}_1 D_0^{-1}] D_0 [\Pi_1 + \mathcal{V}_1 D_0^{-1}] D_0 \\ &= D_0 [\Pi_1^3 D_0^2 + 3\Pi_1^2 \mathcal{V}_1 D_0 + 3\Pi_1 \mathcal{V}_1^2 + \mathcal{V}_1^3 D_0^{-1}] D_0 \\ &= L_1 + D_0 [3\Pi_1^2 \mathcal{V}_1 D_0 + 3\Pi_1 \mathcal{V}_1^2 + \mathcal{V}_1^3 D_0^{-1}] D_0. \end{aligned} \quad (\text{A2})$$

In a similar way, we have, for the string containing a $\hat{\Pi}_1$ and $\hat{\Pi}_2$,

$$\begin{aligned} \hat{L}_2 &= 2D_0 \hat{\Pi}_1 D_0 \hat{\Pi}_2 D_0 \\ &= 2D_0 [\Pi_1 + \mathcal{V}_1 D_0^{-1}] D_0 [\Pi_2 + \mathcal{V}_2 D_0^{-1} + \mathcal{B}_2 D_0^{-2} + \tilde{R}_2] D_0 \\ &= 2D_0 [\Pi_1 \Pi_2 D_0 + (\Pi_1 \mathcal{V}_2 + \Pi_2 \mathcal{V}_1 - \Pi_1 \mathcal{V}_1^2) - \Pi_1^2 \mathcal{V}_1 D_0 + (\Pi_1 \mathcal{B}_2 + \mathcal{V}_1 \mathcal{V}_2) D_0^{-1} + \mathcal{V}_1 \mathcal{B}_2 D_0^{-2}] D_0 \\ &= L_2 + 2D_0 [(\Pi_1 \mathcal{V}_2 + \Pi_2 \mathcal{V}_1 - \Pi_1 \mathcal{V}_1^2) - \Pi_1^2 \mathcal{V}_1 D_0 + (\Pi_1 \mathcal{B}_2 + \mathcal{V}_1 \mathcal{V}_2) D_0^{-1} + \mathcal{V}_1 \mathcal{B}_2 D_0^{-2}] D_0, \end{aligned} \quad (\text{A3})$$

where we used that $\tilde{R}_2 = -\Pi_1 \mathcal{V}_1$. From the graphs depicted in Fig. 10, we receive the propagatorlike pinch contributions L_3 , L_4 , L_5 , L_6 , and L_7 , respectively, given by

$$L_3 = D_0 \Pi_1 D_0 \mathcal{V}_2 = D_0 [\Pi_1 \mathcal{V}_2] D_0, \quad (\text{A4})$$

$$L_4 = D_0 \Pi_2 D_0 \mathcal{V}_1 = D_0 [\Pi_2 \mathcal{V}_1] D_0, \quad (\text{A5})$$

$$L_5 = D_0 \Pi_1 D_0 \Pi_1 D_0 \mathcal{V}_1 = D_0 [\Pi_1^2 \mathcal{V}_1 D_0] D_0, \quad (\text{A6})$$

$$L_6 = \frac{1}{4} \mathcal{V}_1 D_0 \Pi_1 D_0 \mathcal{V}_1 = D_0 [\frac{1}{4} \Pi_1 \mathcal{V}_1^2] D_0, \quad (\text{A7})$$

$$L_7 = \frac{1}{2} \mathcal{V}_1 D_0 \mathcal{V}_2 = D_0 [\frac{1}{2} \mathcal{V}_1 \mathcal{V}_2 D_0^{-1}] D_0. \quad (\text{A8})$$

We now add by parts the hatted and unhatted quantities from Eqs. (A1)–(A8); their difference represents the contributions one has to add (and subsequently subtract, as described in Sec. II) in order to convert “unhatted” strings into “hatted” strings. Using the fact that $\mathcal{V}_1 = V_1$, $\mathcal{V}_2 = -\frac{3}{4} V_1^2$, and

$$\mathcal{V}_2 = V_2 + v_2 = V_2 - \frac{3}{4} V_1^2, \quad (\text{A9})$$

we finally have

$$\sum_{i=1}^7 L_i = \sum_{j=1}^2 \hat{L}_j + D_0 R_3 D_0 \quad (\text{A10})$$

with

$$\begin{aligned} R_3 &= -[2\Pi_1 \mathcal{B}_2 + \frac{5}{8} \mathcal{V}_1^3 + \frac{3}{2} \mathcal{V}_1 \mathcal{V}_2] D_0^{-1} \\ &\quad - 2\mathcal{V}_1 \mathcal{B}_2 D_0^{-2} - [\Pi_1 \mathcal{V}_2 + \Pi_2 \mathcal{V}_1]. \end{aligned} \quad (\text{A11})$$

From Eq. (A11), we obtain

$$v_3 = -[2\Pi_1 \mathcal{B}_2 + \frac{5}{8} \mathcal{V}_1^3 + \frac{3}{2} \mathcal{V}_1 \mathcal{V}_2], \quad (\text{A12})$$

$$b_3 = -2\mathcal{V}_1 \mathcal{B}_2, \quad (\text{A13})$$

and

$$\tilde{R}_3 = -[\Pi_1 \mathcal{V}_2 + \Pi_2 \mathcal{V}_1]. \quad (\text{A14})$$

We notice that all unwanted terms proportional to $\Pi_1^2 \mathcal{V}_1 D_0$ have canceled against each other as they should. \tilde{R}_3 of Eq. (A14) is precisely what Eq. (5.19) predicts for $k = 3$, namely Eq. (A1). As we explained in Sec. III, the R_3 terms, together with the V_3 and \mathcal{B}_3 propagatorlike pinch terms will eventually convert Π_3 to $\hat{\Pi}_3$.

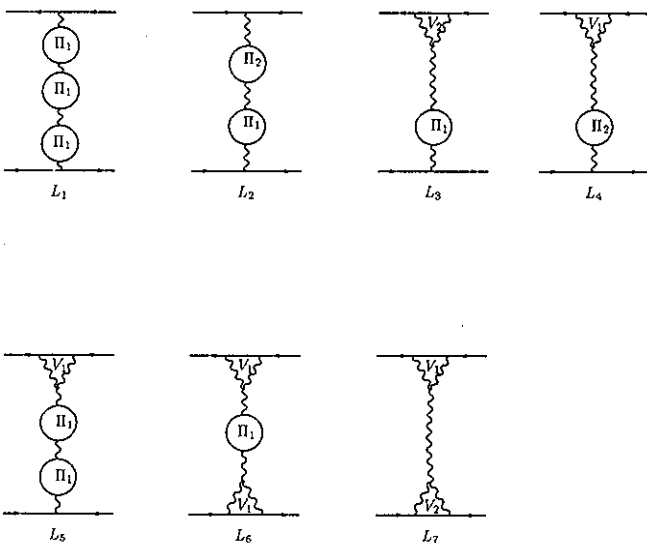

FIG. 10. Structures of Feynman graphs responsible for the vanishing of the shift of the pole at the three-loop case—see, also, Appendix A.

Having gained enough insight on the structure of the \tilde{R}^P terms through the study of explicit examples, we can now generalize our arguments to obtain Eq. (5.19). For the rest of this appendix we restore the superscript "P."

The basic observation is that the conversion of regular strings of order n into "hatted" strings gives rise to \tilde{R}_n^P terms only when (a) the regular string is of the form $D_0\Pi_k D_0\Pi_\ell D_0$, with $k + \ell = n$, or (b) the regular string is of the form $D_0\Pi_k D_0\Pi_\ell D_0\Pi_j D_0$, with $k + \ell + j = n$.

In other words, only strings with two or three self-energy bubbles give rise to \tilde{R}_n^P terms. To understand the reason for that, let us consider a string of order n , consisting of more than three self-energy insertions, i.e.,

$$D_0\Pi_{i_1} D_0\Pi_{i_2} D_0\Pi_{i_3} D_0\{\dots\} D_0\Pi_{i_{k-1}} D_0\Pi_{i_k} D_0,$$

where $k > 3$, and $\sum_{j=1}^k (i_j) = n$. As discussed in Sec. III, in order to convert any of the self-energy bubbles Π_{i_ℓ} into $\hat{\Pi}_{i_\ell}$ we must supply the appropriate pinch terms of order i_ℓ [see Eq. (4.1)], and subsequently subtract them from other appropriately chosen graphs. These extra vertexlike pinch terms, of the form $\mathcal{V}_{i_\ell}^P D_0^{-1}$, cancel one of the D_0 in the string, and give rise to strings of the form

$$D_0\Pi_{i_1} D_0\Pi_{i_2} D_0\{\dots\} D_0\Pi_{i_{\ell-2}} D_0[\Pi_{i_{\ell-1}} \mathcal{V}_{i_\ell}^P] D_0\{\dots\} \\ \times D_0\Pi_{i_{k-1}} D_0\Pi_{i_k} D_0,$$

$$D_0\Pi_{i_1} D_0\Pi_{i_2} D_0\{\dots\} D_0\Pi_{i_{\ell-1}} D_0[\mathcal{V}_{i_\ell} \Pi_{i_{\ell+1}}] \\ \times D_0\{\dots\} D_0\Pi_{i_{k-1}} D_0\Pi_{i_k} D_0,$$

whereas the $D_0^{-1} \mathcal{B}_\ell^P D_0^{-1}$ boxlike terms cancel two of the internal D_0 , thus leading to a string of the type

$$D_0\Pi_{i_1} D_0\Pi_{i_2} D_0\{\dots\} D_0\Pi_{i_{\ell-2}} D_0[\Pi_{i_{\ell-1}} \mathcal{B}_{i_\ell}^P \Pi_{i_{\ell+1}}] \\ \times D_0\{\dots\} D_0\Pi_{i_{k-1}} D_0\Pi_{i_k} D_0.$$

The terms inside square brackets in the above expressions contribute to the quantities $\tilde{R}_{(i_{\ell-1}+i_\ell)}^P$, $\tilde{R}_{(i_\ell+i_{\ell+1})}^P$, and $\tilde{R}_{(i_{\ell-1}+i_\ell+i_{\ell+1})}^P$, respectively. They will correspondingly be added to the strings

$$D_0\Pi_{i_1} D_0\Pi_{i_2} D_0\{\dots\} D_0\Pi_{i_{\ell-2}} D_0[\Pi_{(i_{\ell-1}+i_\ell)}] D_0\{\dots\} \\ \times D_0\Pi_{i_{k-1}} D_0\Pi_{i_k} D_0,$$

$$D_0\Pi_{i_1} D_0\Pi_{i_2} D_0\{\dots\} D_0\Pi_{i_{\ell-1}} D_0[\Pi_{(i_\ell+i_{\ell+1})}] D_0\{\dots\} \\ \times D_0\Pi_{i_{k-1}} D_0\Pi_{i_k} D_0,$$

$$D_0\Pi_{i_1} D_0\Pi_{i_2} D_0\{\dots\} D_0\Pi_{i_{\ell-2}} D_0[\Pi_{(i_{\ell-1}+i_\ell+i_{\ell+1})}] \\ \times D_0\{\dots\} D_0\Pi_{i_{k-1}} D_0\Pi_{i_k} D_0,$$

in order to eventually convert $\Pi_{(i_{\ell-1}+i_\ell)}$, $\Pi_{(i_\ell+i_{\ell+1})}$, and $\Pi_{(i_{\ell-1}+i_\ell+i_{\ell+1})}$ into $\hat{\Pi}_{(i_{\ell-1}+i_\ell)}$, $\hat{\Pi}_{(i_\ell+i_{\ell+1})}$, and

$\hat{\Pi}_{(i_{\ell-1}+i_\ell+i_{\ell+1})}$, respectively. For example, the vertexlike piece $\mathcal{V}_{i_2}^P D_0^{-1}$ will give rise to a string of the form

$$D_0\Pi_{i_1} D_0[\mathcal{V}_{i_2}^P \Pi_{i_3}] D_0\{\dots\} D_0\Pi_{i_{k-1}} D_0\Pi_{i_k} D_0,$$

which will be added to the string $D_0\Pi_{i_1} D_0\Pi_{(i_2+i_3)} D_0\{\dots\} D_0\Pi_{i_{k-1}} D_0\Pi_{i_k} D_0$, as part of the $\tilde{R}_{(i_2+i_3)}^P$ term, whereas the boxlike piece $\mathcal{B}_{i_2}^P D_0^{-2}$ will produce a string

$$D_0[\Pi_{i_1} \mathcal{B}_{i_2}^P \Pi_{i_3}] D_0\{\dots\} D_0\Pi_{i_{k-1}} D_0\Pi_{i_k} D_0,$$

which will be added to the string $D_0\Pi_{(i_1+i_2+i_3)} D_0\{\dots\} D_0\Pi_{i_{k-1}} D_0\Pi_{i_k} D_0$, as part of the $\tilde{R}_{(i_1+i_2+i_3)}^P$ terms.

We see therefore that the terms that one needs to add to a string of order n , which contains more than three self-energy bubbles, will be absorbed by other strings of the same order, containing a smaller number of bubbles. Therefore, the only time that one will obtain terms which must be added to the string containing the single self-energy $\Pi_{(i_1+i_2+\dots+i_{k-1}+i_k)} = \Pi_n$, e.g., they are part of \tilde{R}_n^P , is if the string has a maximum number of three self-energies [(a) or (b) above]. A string of type (a) has the form $L_{(k,n-k)}^{(a)} = D_0\Pi_k D_0\Pi_{n-k} D_0$ and produces a $\tilde{R}_{(k,n-k)}^P$ term, given by $\tilde{R}_{(k,n-k)}^P = -\frac{1}{2}[\Pi_k \mathcal{V}_{n-k}^P + \mathcal{V}_k^P \Pi_{n-k}]$. Of course, for every $L_{(k,n-k)}^{(a)}$ there is a $L_{(n-k,k)}^{(a)}$, giving rise to $\tilde{R}_{(k,n-k)}^P = \tilde{R}_{(n-k,n)}^P$. So, the total contribution of strings of type (a) to \tilde{R}_n^P is

$$\tilde{R}_{n,(a)}^P = \sum_{k=1}^n \tilde{R}_{(k,n-k)}^P = - \sum_{k=1}^n \Pi_k \mathcal{V}_{n-k}^P. \quad (\text{A15})$$

We now turn to the strings of type (b); their general structure is $L_{(\ell,n-j,j-\ell)}^{(b)} = D_0\Pi_\ell D_0\Pi_{n-j} D_0\Pi_{j-\ell} D_0$, and the contribution to \tilde{R}_n^P comes from the boxlike pinch contribution \mathcal{B}_{n-j}^P to the self-energy Π_{n-j} , in the middle of the string. So, the contribution $\tilde{R}_{(\ell,n-j,j-\ell)}^P$ from $L_{(\ell,n-j,j-\ell)}^{(b)}$ is given by $\tilde{R}_{(\ell,n-j,j-\ell)}^P = -\Pi_\ell \Pi_{j-\ell} \mathcal{B}_{n-j}^P$, and the total contribution from strings of type (b) is

$$\tilde{R}_{n,(b)}^P = \sum_{j=1}^n \sum_{\ell=1}^j \tilde{R}_{(\ell,n-j,j-\ell)}^P = - \sum_{j=1}^n \sum_{\ell=1}^j \Pi_\ell \Pi_{j-\ell} \mathcal{B}_{n-j}^P. \quad (\text{A16})$$

Clearly, $\tilde{R}_n^P = \tilde{R}_{n,(a)}^P + \tilde{R}_{n,(b)}^P$, which is Eq. (5.19) (for $k = n$).

APPENDIX B: ONE-LOOP FUNCTIONS

Using the sum convention of the momenta $q + p_1 + p_2 = 0$, we first define the useful integrals

$$I_{ij}(q) = \mu^{4-n} \int \frac{d^n k}{i(2\pi)^n} \frac{1}{(k^2 - M_i^2)[(k+q)^2 - M_j^2]}, \quad (\text{B1})$$

$$J_{ijk}(q, p_1, p_2) = \int \frac{d^n k}{i(2\pi)^n} \frac{1}{[(k+p_1)^2 - M_i^2][(k-p_2)^2 - M_j^2](k^2 - M_k^2)}, \quad (\text{B2})$$

$$\begin{aligned} J_{ijk}^\mu(q, p_1, p_2) &= \int \frac{d^n k}{i(2\pi)^n} \frac{k^\mu}{[(k+p_1)^2 - M_i^2][(k-p_2)^2 - M_j^2](k^2 - M_k^2)} \\ &= p_1^\mu J_{ijk}^-(q, p_1, p_2) + p_2^\mu J_{ijk}^+(q, p_1, p_2) \end{aligned} \quad (\text{B3})$$

where the loop integrals are analytically continued in dimensions $n = 4 - 2\epsilon$. Armed with the one loop functions given in Eqs. (B1)–(B3), we can now present the analytic expressions for the functions B , B^\pm , and \mathcal{M}^\pm [22]. They are given by

$$\mathcal{M}^-(q, p_-, p_+) = g_w^2 \left(\frac{s_w^2}{c_w^2} J_{WW\gamma} + \frac{c_w^2 - s_w^2}{2c_w^2} J_{WWZ} + \frac{1}{2} J_{WWH} + \frac{1}{2c_w^2} J_{ZHW} \right), \quad (\text{B4})$$

$$\mathcal{M}^+(q, p_-, p_+) = -\mathcal{M}^-(q, p_+, p_-), \quad (\text{B5})$$

$$\begin{aligned} B_{\mu\nu\lambda}(q, p_-, p_+) &= \sum_{V=\gamma, Z} g_V^2 \left\{ g_{\nu\lambda} \left[p_{-\mu} (J_{WWV}^- - \frac{3}{2} J_{WWV}) + p_{+\mu} (J_{WWV}^+ + \frac{3}{2} J_{WWV}) \right] \right. \\ &\quad \left. - g_{\mu\nu} (3p_{-\lambda} J_{WWV}^- + 3p_{+\lambda} J_{WWV}^+ + 2q_\lambda J_{WWV}) - g_{\mu\lambda} (3p_{-\nu} J_{WWV}^- + 3p_{+\nu} J_{WWV}^+ - 2q_\nu J_{WWV}) \right\}, \end{aligned} \quad (\text{B6})$$

$$\begin{aligned} B_{\mu\nu\lambda}^-(q, p_-, p_+) &= \sum_{V=\gamma, Z} g_V^2 \left\{ g_{\nu\lambda} \left[3p_{-\mu} (J_{WWV}^- + J_{WWV}) + p_{+\mu} (3J_{WWV}^+ - 2J_{WWV}) \right] \right. \\ &\quad \left. + g_{\mu\lambda} \left[p_{-\nu} (3J_{WWV}^- + J_{WWV}) + 3p_{+\nu} J_{WWV}^+ - 2q_\nu J_{WWV} \right] \right. \\ &\quad \left. - g_{\nu\mu} \left[p_{-\lambda} (J_{WWV}^- + 2J_{WWV}) + p_{+\lambda} J_{WWV}^+ - 2q_\lambda J_{WWV} \right] \right\}, \end{aligned} \quad (\text{B7})$$

$$B_{\mu\nu\lambda}^+(q, p_-, p_+) = -B_{\mu\lambda\nu}^-(q, p_+, p_-), \quad (\text{B8})$$

where the coupling constants have been abbreviated by $g_\gamma = g_w s_w = e$ and $g_Z = g_w c_w$, with $s_w = \sin \theta_w$, $c_w = \cos \theta_w$, and θ_w being the electroweak mixing angle. The arguments of the functions J , J_{ijk} , and J_{ijk}^\pm should be evaluated at (q, p_-, p_+) .

The one loop functions I_{ij} , J_{ijk} , and J_{ijk}^μ defined in Eqs. (B1)–(B3) are closely related to the Passarino-Veltman [46] integrals. In this way, if we adopt the Minkowskian metric $g^{\mu\nu} = \text{diag}(1, -1, -1, -1)$ in our conventions, very similar to Ref. [47], we can make the identifications

$$I_{ij}(q) = \frac{1}{16\pi^2} (1 + 2\epsilon \ln 2\pi\mu) B_0(q^2, M_i^2, M_j^2), \quad (\text{B9})$$

$$J_{ijk}(q, p_1, p_2) = -\frac{1}{16\pi^2} C_0(p_1^2, q^2, p_2^2, M_k^2, M_i^2, M_j^2), \quad (\text{B10})$$

$$\begin{aligned} J_{ijk}^\mu(q, p_1, p_2) &= -\frac{1}{16\pi^2} \left[p_1^\mu C_{11}(p_1^2, q^2, p_2^2, M_k^2, M_i^2, M_j^2) \right. \\ &\quad \left. + q^\mu C_{12}(p_1^2, q^2, p_2^2, M_k^2, M_i^2, M_j^2) \right]. \end{aligned} \quad (\text{B11})$$

From Eq. (B11), it is then easy to derive that

$$\begin{aligned} J_{ijk}^-(q, p_1, p_2) &= \frac{1}{16\pi^2} \left[C_1(p_1^2, q^2, p_2^2, M_k^2, M_i^2, M_j^2) \right. \\ &\quad \left. - C_{12}(p_1^2, q^2, p_2^2, M_k^2, M_i^2, M_j^2) \right], \end{aligned} \quad (\text{B12})$$

$$J_{ijk}^+(q, p_1, p_2) = \frac{1}{16\pi^2} C_{12}(p_1^2, q^2, p_2^2, M_k^2, M_i^2, M_j^2). \quad (\text{B13})$$

APPENDIX C: WARD IDENTITIES FOR THE ZWW VERTEX

Using the PT, one can derive all the relevant Ward identities related to the ZWW vertex, which warrant an analytic GI result. These identities are listed below:

$$\frac{1}{g_w c_w} [q^\mu \widehat{\Gamma}_{\mu\nu\lambda}^{ZW^-W^+} - M_Z \widehat{\Gamma}_{\nu\lambda}^{G^0W^-W^+}] = \widehat{\Pi}_{\nu\lambda}^W(p_-) - \widehat{\Pi}_{\nu\lambda}^W(p_+), \quad (C1)$$

$$\frac{1}{g_w c_w} [q^\mu \widehat{\Gamma}_{\mu\nu}^{ZW^-G^+} - M_Z \widehat{\Gamma}_\nu^{G^0W^-G^+}] = \widehat{\Theta}_\nu(p_-) + \widehat{\Theta}_\nu(p_+), \quad (C2)$$

$$\frac{1}{g_w c_w} [q^\mu \widehat{\Gamma}_\mu^{ZG^-G^+} - M_Z \widehat{\Gamma}^{G^0G^-G^+}] = \widehat{\Omega}(p_-) - \widehat{\Omega}(p_+), \quad (C3)$$

$$\frac{1}{g_w c_w} [p_-^\nu \widehat{\Gamma}_{\mu\nu\lambda}^{ZW^-W^+} - M_W \widehat{\Gamma}_{\mu\lambda}^{ZG^-W^+}] = \widehat{\Pi}_{\mu\lambda}^W(p_+) - \widehat{\Pi}_{\mu\lambda}^Z(q) - \frac{s_w}{c_w} \widehat{\Pi}_{\mu\lambda}^{Z\gamma}(q), \quad (C4)$$

$$\frac{1}{g_w c_w} [p_+^\lambda \widehat{\Gamma}_{\mu\nu\lambda}^{ZW^-W^+} + M_W \widehat{\Gamma}_{\mu\nu}^{ZW^-G^+}] = -\widehat{\Pi}_{\mu\nu}^W(p_-) + \widehat{\Pi}_{\mu\nu}^Z(q) + \frac{s_w}{c_w} \widehat{\Pi}_{\mu\nu}^{Z\gamma}(q), \quad (C5)$$

$$\frac{1}{g_w c_w} [p_-^\nu \widehat{\Gamma}_{\mu\nu}^{ZW^-G^+} - M_W \widehat{\Gamma}_\mu^{ZG^-G^+}] = -\widehat{\Theta}_\mu(p_+), \quad (C6)$$

$$\frac{1}{g_w c_w} [p_+^\lambda \widehat{\Gamma}_{\mu\lambda}^{ZG^-W^+} + M_W \widehat{\Gamma}_\mu^{ZG^-G^+}] = -\widehat{\Theta}_\mu(p_-), \quad (C7)$$

$$\frac{1}{g_w c_w} [p_-^\nu \widehat{\Gamma}_{\nu\lambda}^{G^0W^-W^+} - c_w q^\mu \widehat{\Gamma}_{\mu\lambda}^{ZG^-W^+}] = c_w \widehat{\Theta}_\lambda(p_-) + c_w \widehat{\Theta}_\lambda(p_+) + \widehat{\Pi}_\lambda^{ZG^0}(q), \quad (C8)$$

$$\frac{1}{g_w c_w} [p_+^\lambda \widehat{\Gamma}_{\nu\lambda}^{G^0W^-W^+} - c_w q^\mu \widehat{\Gamma}_{\mu\nu}^{ZW^-G^+}] = c_w \widehat{\Theta}_\nu(p_-) + c_w \widehat{\Theta}_\nu(p_+) + \widehat{\Pi}_\nu^{ZG^0}(q), \quad (C9)$$

$$\frac{1}{g_w c_w} [p_-^\nu p_+^\lambda \widehat{\Gamma}_{\mu\nu\lambda}^{ZW^-W^+} + M_W^2 \widehat{\Gamma}_\mu^{ZG^-G^+}] = M_W \widehat{\Theta}_\mu(p_+) - M_W \widehat{\Theta}_\mu(p_-) - \frac{1}{2} (p_+ - p_-)^\lambda \left[\widehat{\Pi}_{\mu\lambda}^Z(q) + \frac{s_w}{c_w} \widehat{\Pi}_{\mu\lambda}^{Z\gamma}(q) \right]. \quad (C10)$$

The PT three-point function for the ZWW coupling is related to the conventional vertex in the Feynman gauge via the expression

$$\begin{aligned} \widehat{\Gamma}_{\mu\nu\lambda}^{ZW^-W^+}(q, p_-, p_+) &= \Gamma_{\mu\nu\lambda}^{ZW^-W^+(\xi=1)}(q, p_-, p_+) - g_w c_w \left[U_{Z\mu}^{-1\alpha}(q) B_{\alpha\nu\lambda}(q, p_-, p_+) \right. \\ &\quad \left. + U_{W\nu}^{-1\alpha}(p_-) B_{\mu\alpha\lambda}^+(q, p_-, p_+) + U_{W\lambda}^{-1\alpha}(p_+) B_{\mu\nu\alpha}^-(q, p_-, p_+) \right] \\ &\quad - 2g_w^2 \Gamma_{0\mu\nu\lambda}^{ZW^-W^+}(q, p_-, p_+) \left[I_{WW}(q) + s_w^2 I_{W\gamma}(p_-) + s_w^2 I_{W\gamma}(p_+) \right. \\ &\quad \left. + c_w^2 I_{WZ}(p_-) + c_w^2 I_{WZ}(p_+) \right] + g_w c_w \left[M_W^2 g_{\mu\nu} p_{+\lambda} \mathcal{M}^-(q, p_-, p_+) \right. \\ &\quad \left. + M_W^2 g_{\mu\lambda} p_{-\nu} \mathcal{M}^+(q, p_-, p_+) + M_Z^2 q_\mu g_{\nu\lambda} \mathcal{M}(q, p_-, p_+) \right]. \end{aligned} \quad (C11)$$

In Eq. (C11), $\Gamma_{\mu\nu\lambda}^{ZW^-W^+(\xi=1)}$ is the conventional one loop ZWW vertex calculated in the Feynman gauge. The loop functions I_{ij} , B^\pm , \mathcal{M}^\pm are given in Appendix B, except \mathcal{M} . The analytic result for the latter may be obtained by

$$\mathcal{M}(q, p_-, p_+) = \frac{1}{2} g_w^2 \left[J_{HZW}(q, p_-, p_+) + J_{ZHW}(q, p_-, p_+) \right]. \quad (C12)$$

-
- [1] E. Rutherford and F. Soddy, *Philos. Mag.* **6**, 576 (1903).
[2] V. Weisskopf and E. Wigner, *Z. Phys.* **63**, 54 (1930); **65**, 18 (1930); W. Heitler, *Quantum Theory of Radiation*, 3rd ed. (Oxford University Press, Oxford, 1954).
[3] J. Schwinger, *Ann. Phys.* **9**, 1371 (1958); L. Khalifin, *Zh. Eksp. Teor. Fiz.* **32**, 1371 (1958) [*Sov. Phys. JETP* **6**, 1053 (1958)].
[4] M. Veltman, *Physica* **29**, 186 (1963).
[5] A. Pilaftsis, *Z. Phys. C* **47**, 95 (1990).
[6] S. Willenbrock and G. Valencia, *Phys. Lett. B* **259**, 373 (1991).
[7] R.G. Stuart, *Phys. Lett. B* **262**, 113 (1991); **272**, 353 (1991); *Phys. Rev. Lett.* **70**, 3193 (1993); in *Proceedings of the Perspectives for Electroweak Interactions in e^+e^- Collisions*, Ringberg Castle, Germany, February 1995, edited by B. A. Kuiehl (World Scientific, Singapore, 1995), p. 235.
[8] A. Sirlin, *Phys. Rev. Lett.* **67**, 21 27 (1991); *Phys. Lett. B* **267**, 240 (1991).
[9] M. Nowakowski and A. Pilaftsis, *Z. Phys. C* **60**, 121 (1993).
[10] G. López Castro, J.L. Lucio, and J. Pestieau, *Mod. Phys. Lett. A* **6**, 3679 (1991); Report No. hep-ph/9504351 (unpublished).
[11] H. Veltman, *Z. Phys. C* **62**, 35 (1994).
[12] A. Aeppli, G.J. van Oldenborgh, and D. Wyler, *Nucl. Phys. B* **428**, 126 (1994).
[13] U. Baur and D. Zeppenfeld, *Phys. Rev. Lett.* **75**, 1002

- (1995); C.G. Papadopoulos, *Phys. Lett. B* **352**, 144 (1995).
- [14] E.N. Argyres *et al.*, *Phys. Lett. B* **358**, 339 (1995).
- [15] A. Pilaftsis and M. Nowakowski, *Phys. Lett. B* **245**, 185 (1990).
- [16] M. Nowakowski and A. Pilaftsis, *Mod. Phys. Lett. A* **6**, 1933 (1991); G. Eilam, J.L. Hewett, and A. Soni, *Phys. Rev. Lett.* **67**, 1979 (1991).
- [17] D. Atwood, G. Eilam, A. Soni, R. Mendel, and R. Migneron, *Phys. Rev. D* **49**, 289 (1994).
- [18] U. Baur, J. Vermaseren, and D. Zeppenfeld, *Nucl. Phys.* **B375**, 3 (1992).
- [19] J.M. Cornwall, *Phys. Rev. D* **26**, 1453 (1982).
- [20] J. Papavassiliou, *Phys. Rev. D* **50**, 5958 (1994).
- [21] J. Papavassiliou, *Phys. Rev. D* **41**, 3179 (1990); G. Degrassi and A. Sirlin, *ibid.* **46**, 3104 (1992); J. Papavassiliou and C. Parrinello, *ibid.* **50**, 3059 (1994); G. Degrassi, B. Kniehl, and A. Sirlin, *ibid.* **48**, R3963 (1993); J. Papavassiliou and A. Sirlin, *ibid.* **50**, 5951 (1994).
- [22] J. Papavassiliou and K. Philippides, *Phys. Rev. D* **48**, 4255 (1993).
- [23] J. Papavassiliou and A. Pilaftsis, *Phys. Rev. Lett.* **75**, 3060 (1995).
- [24] H. Lehmann, K. Symanzik, and W. Zimmermann, *Nuovo Cimento.* **1**, 439 (1955); N. Bogoliubov and D. Shirkov, *Fortschr. Phys.* **3**, 439 (1955); N. Bogoliubov, B. Medvedev, and M. Polivanov, *ibid.* **3**, 169 (1958).
- [25] R.J. Eden, P.V. Landshoff, P.J. Olive, and J.C. Polkinghorne, *The Analytic S matrix* (Cambridge University Press, Cambridge, England, 1966).
- [26] C. Becchi, A. Rouet, and R. Stora, *Ann. Phys. (N.Y.)* **98**, 287 (1976).
- [27] J. Papavassiliou and K. Philippides, *Phys. Rev. D* **52**, 2355 (1995).
- [28] N.J. Watson, *Phys. Lett. B* **349**, 155 (1995).
- [29] J.M. Cornwall, R. Jackiw, and E.T. Tomboulis, *Phys. Rev. D* **10**, 2428 (1974); J.M. Cornwall and R. Norton, *Ann. Phys. (N.Y.)* **91**, 106 (1975).
- [30] J.M. Cornwall, *Phys. Rev. D* **38**, 656 (1988); *Physica A* **158**, 97 (1989).
- [31] J. Papavassiliou, (unpublished).
- [32] A. Denner, S. Dittmaier, and G. Weiglein, *Phys. Lett. B* **333**, 420 (1994); S. Hashimoto, J. Kodaira, Y. Yasui, and K. Sasaki, *Phys. Rev. D* **50**, 7066 (1994); J. Papavassiliou, *ibid.* **51**, 856 (1995); E. de Rafael and N.J. Watson (unpublished).
- [33] L.F. Abbott, *Nucl. Phys.* **B185**, 189 (1981), and references therein.
- [34] J.M. Cornwall (private communication).
- [35] K.J.F. Gaemers and G.J. Gounaris, *Z. Phys. C* **1**, 259 (1979); K. Hagiwara, R.D. Peccei, D. Zeppenfeld, and K. Hikasa, *Nucl. Phys.* **B282**, 253 (1987); U. Baur and D. Zeppenfeld, *ibid.* **B308**, 127 (1988); U. Baur and D. Zeppenfeld, *ibid.* **B325**, 253 (1989); G. Belanger, F. Boudjema, and D. London, *Phys. Rev. Lett.* **65**, 2943 (1990).
- [36] W.J. Marciano and A. Sirlin, *Phys. Rev. D* **22**, 2695 (1980).
- [37] E.N. Argyres *et al.*, *Nucl. Phys.* **B391**, 23 (1993).
- [38] K. Aoki *et al.*, *Suppl. Prog. Theor. Phys.* **73**, 1 (1982).
- [39] L. Baulieu and R. Coquereaux, *Ann. Phys.* **140**, 163 (1982).
- [40] For reviews, see, e.g., P. Langacker, *Phys. Rep.* **72**, 185 (1981); R.N. Mohapatra, *Unification and Supersymmetry* (Springer-Verlag, New York, 1986).
- [41] CDF collaboration, F.E. Abe *et al.*, *Phys. Rev. Lett.* **74**, 2626 (1995). Collaboration, S. Abachi *et al.*, *ibid.* **74**, 2632 (1995).
- [42] L.D. Fadeev and Y.N. Popov, *Phys. Lett.* **25B**, 29 (1967).
- [43] N.K. Nielsen, *Nucl. Phys.* **B140**, 499 (1978); R.E. Kallosh, *ibid.* **B141**, 141 (1978).
- [44] G. Gustafson, U. Pettersson, and P. Zerwas, *Phys. Lett. B* **209**, 90 (1988); W. Kwong, *Phys. Rev. D* **43**, 1488 (1991); M.J. Strassler and M.E. Peskin, *ibid.* **43**, 1500 (1991); V.S. Fadin, V.A. Khoze, and A.D. Martin, *Phys. Lett. B* **311**, 311 (1993); T. Sjöstrand and V.A. Khoze, *Phys. Rev. Lett.* **72**, 28 (1994).
- [45] V.S. Fadin and V.A. Khoze, *JETP Lett.* **46**, 525 (1987).
- [46] G. Passarino and M. Veltman, *Nucl. Phys.* **B160**, 151 (1979); G. 't Hooft and M. Veltman, *Nucl. Phys.* **B153**, 365 (1979).
- [47] See, e.g., Appendix A of the review by B.A. Kniehl, *Phys. Rep.* **240**, 211 (1994).