

Evaporation and fate of dilatonic black holes

Jun-Ichirou Koga* and Kei-Ichi Maeda†

Department of Physics, Waseda University, Shinjuku-ku, Tokyo 169, Japan

(Received 7 August 1995)

We study both spherically symmetric and rotating black holes with dilaton coupling and discuss the evaporation of these black holes via Hawking's quantum radiation and their fates. We find that the dilaton coupling constant α drastically affects the emission rates, and therefore the fates of the black holes. When the charge is conserved, the emission rate from the nonrotating hole is drastically changed beyond $\alpha = 1$ (a superstring theory) and diverges in the extreme limit. In the rotating cases we analyze the slowly rotating black hole solution with arbitrary α as well as three exact solutions: the Kerr-Newman ($\alpha = 0$), Kaluza-Klein ($\alpha = \sqrt{3}$), and Sen black hole ($\alpha = 1$ and with axion field). Beyond the same critical value of $\alpha \sim 1$, the emission rate becomes very large near the maximally charged limit, while for $\alpha < 1$ it remains finite. The black hole with $\alpha > 1$ may evolve into a naked singularity due to its large emission rate. We also consider the effects of a discharge process by investigating superradiance for the nonrotating dilatonic black hole.

PACS number(s): 04.70.Dy, 04.50.+h, 04.62.+v

I. INTRODUCTION

The unification of all fundamental interactions including gravity is one of the final goals of theoretical physics. The electromagnetic and weak interactions were unified by Weinberg and Salam, and grand unified theories (GUT's) have been proposed as a unification model of three fundamental interactions. In this unification scheme, all interactions are described by gauge fields. Furthermore, supersymmetry is proposed to unify interaction (bosons) and matter (fermions), and gravity could be included in a supergravity theory. Such unified theories are sometimes discussed in higher dimensions. Then, the idea of superstrings arises as an approach to the unification of all interactions and particles, giving a "theory of everything."

Then we have recognized that gravity is one of the most important keys for unification. In order to understand the role of gravity in a fundamental unified theory, it is necessary and helpful to study concrete physical phenomena with strong gravity such as cosmology or black holes. We find new aspects of gravity and other fundamental fields through such theoretical studies, which might give us hints about unification.

In the effective theories derived from the higher-dimensional unified theories [1], the dilaton field couples to other known matter fields. The coupling constant depends on the fundamental unified theory and the dimensionality of spacetime. Thus it is important to study how the coupling affects physical phenomena. The coupling plays some important roles in black hole physics [2] as well as in cosmology [3]. In this paper, we further study effects of a dilaton field on black hole physics, and in

particular we will analyze the role of Hawking's quantum radiation.

We consider the model with a dilaton field coupled to a U(1) gauge field, i.e., the Einstein-Maxwell-dilaton theory. The action is

$$S = \frac{1}{16\pi} \int d^4x \sqrt{-g} \left[R - 2(\nabla\phi)^2 - e^{-2\alpha\phi} F^2 \right], \quad (1.1)$$

where ϕ and $F_{\mu\nu}$ are a dilaton field and U(1) gauge field, respectively, with a coupling constant α [4]. For a superstring, we may also include an axion field $H_{\mu\nu\rho}$. The action is then

$$S = \frac{1}{16\pi} \int d^4x \sqrt{-g} \left[R - 2(\nabla\phi)^2 - e^{-2\phi} F^2 - \frac{1}{12} e^{-4\phi} H^2 \right]. \quad (1.2)$$

The action (1.1) reduces to the Einstein-Maxwell theory when the coupling constant $\alpha = 0$. The black hole solution for this case is the well-known Kerr-Newman family. The case of $\alpha = \sqrt{3}$ corresponds to the four-dimensional effective model reduced from the five-dimensional Kaluza-Klein theory. The action (1.2), in which the dilaton coupling constant α to the U(1) gauge field is unity, is a bosonic part of the low energy limit of superstring theory.

The exact spherically symmetric dilatonic black hole solution with arbitrary coupling constant α is known [2, 5]. They have some interesting thermodynamical properties, which are not found in the conventional charged (Reissner-Nordström) black hole. In particular, the temperature of the black hole in the extreme limit depends drastically on α . If $\alpha < 1$, the temperature of the black hole vanishes in the extreme limit, as does that of the Reissner-Nordström black hole. On the other hand, the temperature of the extreme black hole with $\alpha > 1$ di-

*Electronic address: 695L5084@cfi.waseda.ac.jp

†Electronic address: maeda@cfi.waseda.ac.jp

verges. For $\alpha = 1$, it is a nonzero finite value. This new thermodynamical property implies that the emission rate of Hawking quantum radiation may be completely different, depending on the coupling constant. We expect that when $\alpha > 1$ the emission rate diverges in the extreme limit, because the temperature diverges. The black hole may evaporate very rapidly. However, it was pointed out [6] that for $\alpha > 1$, the effective potential, over which created particles travel to an asymptotically flat region to evaporate, grows infinitely high in the extreme limit. Hence, Holzhey and Wilczek expected that the emission rate will be suppressed to a finite value. Since these two features are competing processes in Hawking radiation, it is not trivial to decide whether or not the emission rate from the extreme dilatonic black holes with $\alpha > 1$ diverges. Thus, we analyze the emission rates numerically under the assumption that the charge is conserved, and clarify what happens in the extreme limit. This is the main purpose of the present paper.

In addition to the spherically symmetric black hole, rotating dilatonic black holes also have similar thermodynamical properties [7–9]. We considered superradiance around the rotating dilatonic black holes in the previous paper [9] and showed that there is a critical value ($\alpha \sim 1$) beyond which the emission rate changes drastically. In this paper, we extend our analysis to include the role of the temperature, i.e., Hawking quantum radiation, which automatically includes a superradiant effect, and discuss the fate of rotating black holes due to the evaporation process. We only know two exact rotating black hole solutions for the action (1.1): the Kerr-Newman ($\alpha = 0$) and Kaluza-Klein solutions ($\alpha = \sqrt{3}$) [10]. In the superstring case ($\alpha = 1$), Sen [8] derived a rotating black hole solution for the action (1.2). This solution is not exactly the same as those in the model (1.1), but we expect that the existence of the axion field will not drastically change the dependence of the emission rate on the dilaton coupling. Hence, we analyze these three black hole solutions and compare their emission rates. In addition to these exact solutions, we consider an approximate solution of slowly rotating black holes with arbitrary coupling α [7, 11].

All rotating dilatonic black holes reduce to the Kerr solution when their charges vanish. We expect that the coupling constant dependence is most noticeable when the black hole is highly charged. We therefore analyze Hawking radiation from highly charged black holes. As we know, a charged black hole generally emits its charge at a high rate in the process of evaporation and so its charge will be quickly lost, unless the charge is conserved. Because we are now interested in the effect of the dilaton coupling on the emission rates, we first assume that the charge is conserved, which is true for a central charge. We then study the discharge processes to see how it is affected by the dilaton coupling.

This paper is organized as follows. In the next section, we study Hawking radiation for a spherically symmetric dilatonic black hole and analyze the behavior of the emission rate in the extreme limit. The emission rates from rotating black holes are presented in Sec. III. It is assumed that the charge of the black hole is conserved. We

discuss the evolution and fate of these black holes. The effects of the discharge process are considered by calculating superradiance in the spherically symmetric black hole in Sec. IV. Finally, we give our conclusions and remarks in the final section.

II. HAWKING RADIATION FROM SPHERICALLY SYMMETRIC DILATONIC BLACK HOLES

We first consider spherically symmetric dilatonic black holes. In this case we know the exact solution with arbitrary coupling constant α [2, 5], which is given by

$$ds^2 = -\frac{\Delta(\rho)}{R^2(\rho)} dt^2 + \frac{R^2(\rho)}{\Delta(\rho)} d\rho^2 + R^2(\rho)(d\theta^2 + \sin^2\theta d\varphi^2),$$

$$A_t = \frac{Q}{\rho}, \quad \phi = \frac{\alpha}{1+\alpha^2} \ln\left(1 - \frac{\rho_-}{\rho}\right), \quad (2.1)$$

where

$$\Delta(\rho) = (\rho - \rho_+)(\rho - \rho_-), \quad (2.2)$$

$$R(\rho) = \rho \left(1 - \frac{\rho_-}{\rho}\right)^{\alpha^2/(1+\alpha^2)},$$

and A_t is the t component of the gauge potential A_μ . The outer and “inner” horizons ρ_+ and ρ_- are given by the mass M , the electric charge of the black hole Q , and α as

$$\rho_\pm = \frac{(1+\alpha^2)[M \pm \sqrt{M^2 - (1-\alpha^2)Q^2}]}{(1 \pm \alpha^2)}. \quad (2.3)$$

$\rho = \rho_-$ is the curvature singularity for $\alpha \neq 0$. The maximum value of the charge is $Q_{\max} \equiv \sqrt{1+\alpha^2}M$. When $|Q| = Q_{\max}$, ρ_+ and ρ_- coincide, and we call it an extreme black hole. However, it has to be emphasized that when $\rho_+ = \rho_-$, a naked singularity appears at $\rho = \rho_+$ and the area of black hole vanishes for $\alpha \neq 0$, and it is therefore not a black hole solution [2].

The temperature T of the black hole is given as

$$T = \frac{1}{4\pi\rho_+} \left(1 - \frac{\rho_-}{\rho_+}\right)^{(1-\alpha^2)/(1+\alpha^2)}. \quad (2.4)$$

It possesses an interesting property [2]. When $\alpha < 1$, T in the extreme limit vanishes, whereas it diverges in the case of $\alpha > 1$, and has the nonzero finite value $1/8\pi M$ (as the Schwarzschild black hole) for $\alpha = 1$.

Here we consider a neutral and massless scalar field which does not couple to the dilaton field [13], which is described by the Klein-Gordon equation

$$\Phi_{,\mu}{}^{;\mu} = 0. \quad (2.5)$$

The energy emission rate of Hawking radiation is given [14] by

$$\frac{dM}{dt} = -\frac{1}{2\pi} \sum_{l,m} \int_0^\infty \frac{\omega(1-|A|^2)}{\exp[\omega/T] - 1} d\omega, \quad (2.6)$$

where l, m are the angular momentum and its azimuthal

component, ω is the energy of the particle, and $|A|^2$ is a reflection coefficient in a scattering problem for the scalar field Φ . The Klein-Gordon equation (2.5) in this black hole spacetime can be made separable, by setting

$$\Phi = \frac{\chi(\rho^*)}{R(\rho)} S(\theta) e^{im\varphi} e^{-i\omega t}. \quad (2.7)$$

Then, Eq. (2.5) is reduced to the Legendre equation for $S(\theta)$ and the radial equation

$$\left[\frac{d^2}{d\rho^{*2}} + \omega^2 - V^2(\rho) \right] \chi(\rho^*) = 0, \quad (2.8)$$

where

$$V^2(\rho) \equiv \frac{\Delta(\rho)}{R^2(\rho)} \left[\frac{l(l+1)}{R^2(\rho)} + \frac{1}{R(\rho)} \frac{d}{d\rho} \left(\frac{\Delta(\rho)}{R^2(\rho)} \frac{dR(\rho)}{d\rho} \right) \right], \quad (2.9)$$

$$d\rho^* \equiv \frac{R^2(\rho)}{\Delta(\rho)} d\rho. \quad (2.10)$$

The reflection coefficient $|A|^2$ can be calculated by solving the wave equation (2.8) numerically under the boundary condition

$$\begin{aligned} \chi &\rightarrow e^{-i\omega\rho^*} + Ae^{i\omega\rho^*} & \text{as } \rho^* \rightarrow \infty, \\ \chi &\rightarrow Be^{-i\omega\rho^*} & \text{as } \rho^* \rightarrow -\infty. \end{aligned} \quad (2.11)$$

The dependence of the temperature T on α might be expected to imply that the behavior of Hawking radiation, which is thermal and has an emission rate proportional to T^4 , is drastically affected by the dilaton coupling, particularly for $\alpha > 1$, for which the temperature T diverges in the extreme limit. However, as Holzhey and Wilczek [6] pointed out, since the effective potential V [Eq. (2.9)] for $\alpha > 1$ grows infinitely high at the horizon in the extreme limit, the transmission probability $1 - |A|^2$ for particles to escape to infinity is suppressed. These two tendencies have opposite effects on Hawking radiation, and it is not clear whether or not the emission rate is actually suppressed. Here, we solve the wave equation (2.8) numerically to get the spectrum, and integrate Eq. (2.6). In this and subsequent calculations, we consider only the dominant modes with $l \leq 1$ since the contribution from higher angular momentum modes is suppressed by the centrifugal barrier. We integrate Eq. (2.6) numerically to ω_{\max} ($\omega_{\max} = 25T$ for the present nonrotating case), which is justified since the spectrum is suppressed at the high energy regime by the exponential decay in the Planck distribution.

To see how the emission rate varies as the black hole reaches to the extreme limit, we plot the emission rate, normalized by mass of the black hole M , against Q/Q_{\max} for five values of the coupling constant: $\alpha = 0, 0.5, 1, 1.5, 2$. It is shown in Fig. 1. Here, we assume the charge of the black hole is positive, without loss of generality. In this figure, we see that although the emission rates for each value of α coincide at $Q = 0$, since the black hole solution, with any α , is identically the Schwarzschild spacetime for $Q = 0$, the difference becomes large as the charge increases. In particular, the emission rate for

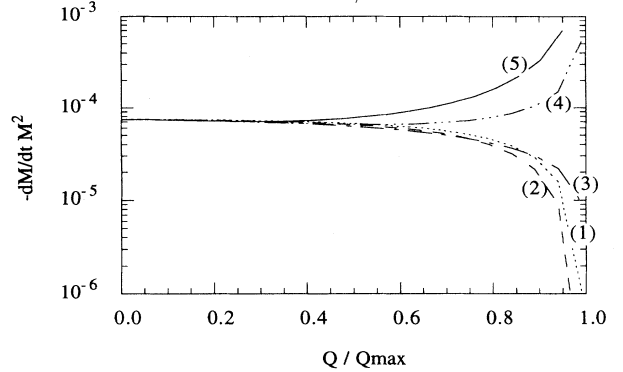

FIG. 1. The emission rate for the nonrotating dilatonic black holes. The charge Q is normalized by Q_{\max} and the emission rate $-dM/dt$ is normalized by M . Each line corresponds to (1) $\alpha = 0$, (2) $\alpha = 0.5$, (3) $\alpha = 1$, (4) $\alpha = 1.5$, and (5) $\alpha = 2$, respectively.

$\alpha > 1$ blows up near the extreme limit. This means that the divergence of the temperature T in the extreme limit overcomes that of the potential V . Furthermore, the emission rate (2.6) of the extreme black hole with $\alpha < 1$ is exactly zero because the temperature vanishes, and that for $\alpha = 1$ is nonzero but finite, as we see in the figure. Therefore, we may conclude that the behavior of the emission rate in the extreme limit changes drastically at the value of $\alpha = 1$, as we naively expect from the behavior of the temperature, despite the effect of the potential barrier. We may also speculate that nearly extreme black holes with $\alpha > 1$ are not stable objects.

III. HAWKING RADIATION FROM ROTATING DILATONIC BLACK HOLES

A. Rotating dilatonic black holes

Next, we consider Hawking radiation from rotating black holes. In the rotating case, we know only two exact solutions in the model (1.1): the Kerr-Newman ($\alpha = 0$) and the Kaluza-Klein ($\alpha = \sqrt{3}$) solutions [10]. In addition to these two, in the $\alpha = 1$ case, an exact rotating black hole solution is derived by Sen [8] in the model (1.2). We first summarize these exact solutions and their thermodynamical properties.

First, the Kerr-Newman black hole solution is expressed as

$$\begin{aligned} ds^2 &= -\frac{\Delta - a^2 \sin^2 \theta}{\Sigma} dt^2 \\ &\quad - \frac{2a \sin^2 \theta (r^2 + a^2 - \Delta)}{\Sigma} dt d\varphi \\ &\quad + \frac{(r^2 + a^2)^2 - \Delta a^2 \sin^2 \theta}{\Sigma} \sin^2 \theta d\varphi^2 \\ &\quad + \frac{\Sigma}{\Delta} dr^2 + \Sigma d\theta^2, \\ A_t &= \frac{Qr}{\Sigma}, \quad A_\varphi = -\frac{aQr \sin^2 \theta}{\Sigma}, \end{aligned} \quad (3.1)$$

where the functions Δ and Σ are defined by

$$\Delta \equiv r^2 - 2Mr + a^2 + Q^2, \quad \Sigma \equiv r^2 + a^2 \cos^2 \theta. \quad (3.2)$$

The coordinates r and ρ in the previous section are related by $r = \rho - \rho_-$ in the spherically symmetric case. The temperature T and the angular velocity Ω_H are given by

$$T = \frac{1}{2\pi} \frac{\sqrt{M^2 - a^2 - Q^2}}{r_H^2 + a^2}, \quad (3.3)$$

$$\Omega_H = \frac{a}{r_H^2 + a^2}, \quad (3.4)$$

where

$$r_H = M + \sqrt{M^2 - a^2 - Q^2} \quad (3.5)$$

is the horizon radius, and M , Q , and $J = Ma$ are the mass, the charge, and the angular momentum of the black hole, respectively.

Second, the Kaluza-Klein black hole solution is derived by a dimensional reduction of the boosted five-dimensional Kerr solution to four dimensions [10, 12]. It is given by

$$ds^2 = -\frac{\Delta - a^2 \sin^2 \theta}{B\Sigma} dt^2 - 2a \sin^2 \theta \frac{1}{\sqrt{1-v^2}} \frac{Z}{B} dt d\varphi + \left[B(r^2 + a^2) + a^2 \sin^2 \theta \frac{Z}{B} \right] \sin^2 \theta d\varphi^2 + \frac{B\Sigma}{\Delta} dr^2 + B\Sigma d\theta^2, \quad (3.6)$$

$$A_t = \frac{v}{2(1-v^2)} \frac{Z}{B^2}, \quad A_\varphi = -a \sin^2 \theta \frac{v}{2\sqrt{1-v^2}} \frac{Z}{B^2}, \quad \phi = -\frac{\sqrt{3}}{2} \ln B,$$

where

$$\Delta \equiv r^2 - 2\mu r + a^2, \quad \Sigma \equiv r^2 + a^2 \cos^2 \theta, \quad Z \equiv \frac{2\mu r}{\Sigma}, \quad B \equiv \left(1 + \frac{v^2 Z}{1-v^2} \right)^{\frac{1}{2}}. \quad (3.7)$$

The physical mass M , the charge Q , and the angular momentum J are expressed by the parameters v , μ , and a , as

$$M = \mu \left[1 + \frac{v^2}{2(1-v^2)} \right], \quad Q = \frac{\mu v}{1-v^2}, \quad J = \frac{\mu a}{\sqrt{1-v^2}}. \quad (3.8)$$

The horizon radius is given by

$$r_H = \mu + \sqrt{\mu^2 - a^2}, \quad (3.9)$$

and then the regular horizon exists if

$$\mu^2 \geq a^2, \quad (3.10)$$

and this condition may be rewritten as

$$\left(\frac{J}{M^2} \right)^2 \leq \frac{1}{4} \left\{ 2 - 10 \left(\frac{Q}{M} \right)^2 - \left(\frac{Q}{M} \right)^4 + 2 \left[1 + 2 \left(\frac{Q}{M} \right)^2 \right]^{3/2} \right\}. \quad (3.11)$$

The parameter range of the condition (3.11) is shown in Fig. 2. It should be noted again that the solutions with $|Q| = Q_{\max}$ ($= 2M$) are not black hole solutions and these points are indicated by small circles in Fig. 2.

As for the thermodynamical properties of this black hole, we find that the temperature T and the angular velocity Ω_H are given as

$$T = \frac{\sqrt{1-v^2}}{2\pi} \frac{\sqrt{\mu^2 - a^2}}{r_H^2 + a^2}, \quad (3.12)$$

$$\Omega_H = \frac{a\sqrt{1-v^2}}{r_H^2 + a^2}. \quad (3.13)$$

The temperature T in the limit of $|Q| \rightarrow Q_{\max}$ for the nonrotating black hole diverges, as was pointed out in the previous section. However, the temperature T of the extreme rotating black hole ($\mu = |a|$) vanishes from Eq. (3.12). When we take the limit $|Q| \rightarrow Q_{\max}$, keeping the black hole extreme with $J \neq 0$ (whereas $J \rightarrow 0$ in the limit), the limiting value is still zero, and different from that of the nonrotating case. That is, the temperature is discontinuous at $|Q| = Q_{\max}$ where a naked singularity appears. A similar feature is found in the behavior of Ω_H . If we take a limit $|Q| \rightarrow Q_{\max}$, Ω_H of a rotating black hole diverges, whereas Ω_H of a nonrotating black hole is zero. The fact that J vanishes while Ω_H diverges

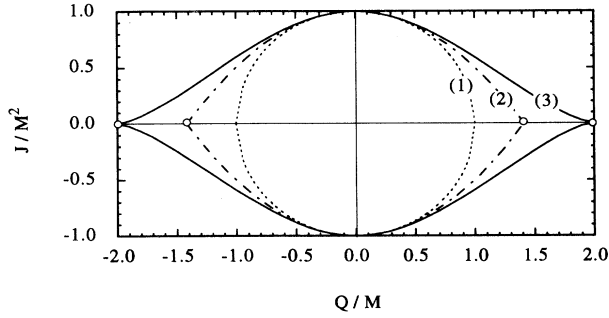

FIG. 2. The parameter ranges of three types of black hole. The extreme lines are shown in the Q/M - J/M^2 plane for (1) the Kerr-Newman, (2) the Sen, and (3) the Kaluza-Klein black holes. The region inside each line guarantees a regular event horizon, except the points denoted by a small circle where a naked singularity appears.

in the limit $|Q| \rightarrow Q_{\max}$ is understood by observing that the area of the black hole vanishes in that limit. Those features are illustrated in Fig. 3.

Third, the Sen black hole [8], which is a solution in the action (1.2), is expressed as

$$\begin{aligned}
 ds^2 &= -\frac{\Delta - a^2 \sin^2 \theta}{\Sigma} dt^2 - \frac{4\mu r a \cosh^2 \beta \sin^2 \theta}{\Sigma} dt d\varphi \\
 &\quad + \frac{\Sigma}{\Delta} dr^2 + \Sigma d\theta^2 + \frac{\Lambda}{\Sigma} \sin^2 \theta d\varphi^2, \\
 A_t &= \frac{1}{\sqrt{2}} \frac{\mu r \sinh 2\beta}{\Sigma}, \quad A_\varphi = -\frac{a}{\sqrt{2}} \sin^2 \theta \frac{\mu r \sinh 2\beta}{\Sigma}, \\
 \phi &= -\frac{1}{2} \ln \frac{\Sigma}{r^2 + a^2 \cos^2 \theta}, \\
 B_{t\varphi} &= 2a \sin^2 \theta \frac{\mu r \sinh^2 \beta}{\Sigma}, \tag{3.14}
 \end{aligned}$$

where the functions Δ , Σ , and Λ are defined by

$$\begin{aligned}
 \Delta &\equiv r^2 - 2\mu r + a^2, \quad \Sigma \equiv r^2 + a^2 \cos^2 \theta + 2\mu r \sinh^2 \beta, \\
 \Lambda &\equiv (r^2 + a^2)(r^2 + a^2 \cos^2 \theta) + 2\mu r a^2 \sin^2 \theta \\
 &\quad + 4\mu r (r^2 + a^2) \sinh^2 \beta + 4\mu^2 r^2 \sinh^4 \beta. \tag{3.15}
 \end{aligned}$$

The antisymmetric two rank tensor $B_{\mu\nu}$ generates the axion field $H_{\mu\nu\rho}$, together with A_μ , by

$$H_{\mu\nu\rho} = (\partial_\mu B_{\nu\rho} - 2A_\mu F_{\nu\rho}) + [\text{cyclic permutations}]. \tag{3.16}$$

The mass M , the charge Q , and the angular momentum J are given by parameters μ , β , and a as

$$\begin{aligned}
 M &= \frac{\mu}{2} (1 + \cosh 2\beta), \quad Q = \frac{\mu}{\sqrt{2}} \sinh 2\beta, \\
 J &= \frac{a\mu}{2} (1 + \cosh 2\beta), \tag{3.17}
 \end{aligned}$$

and the horizon radius is given by the same equation as Eq. (3.9). The condition for the solution to be a black hole is also the same as Eq. (3.10), which is now rewritten as

$$|J| \leq M^2 - \frac{Q^2}{2}. \tag{3.18}$$

The parameter range of the condition (3.18) is also shown in Fig. 2.

This black hole has similar thermodynamical properties to the Kaluza-Klein solution. The temperature T and the angular velocity Ω_H of this black hole are given by

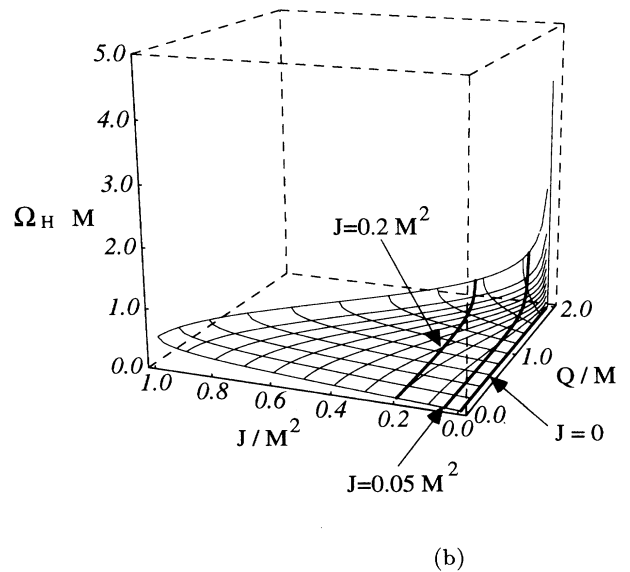
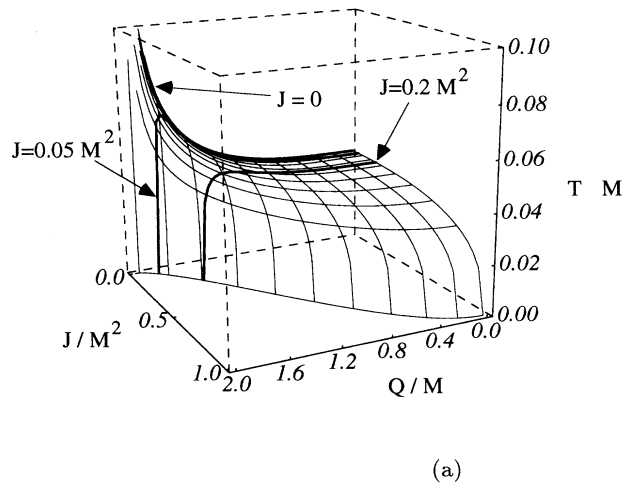

FIG. 3. The thermodynamical behavior of the Kaluza-Klein black hole. The behavior of (a) the temperature T and (b) the angular velocity Ω_H is depicted on the Q/M - J/M^2 plane ($Q \geq 0, J \geq 0$). The constant angular momentum lines are drawn in solid lines for $J = 0, 0.05M^2$, and $0.2M^2$.

$$T = \frac{\sqrt{(2M^2 - Q^2)^2 - 4J^2}}{4\pi M \left[2M^2 - Q^2 + \sqrt{(2M^2 - Q^2)^2 - 4J^2} \right]},$$

$$\Omega_H = \frac{J}{M \left[2M^2 - Q^2 + \sqrt{(2M^2 - Q^2)^2 - 4J^2} \right]}, \quad (3.19)$$

and these quantities are discontinuous at $|Q| = Q_{\max} (= \sqrt{2}M)$, although they never diverge but approach finite values. The behavior of these quantities is shown in Fig. 4.

These discontinuities indicate that the emission rate of Hawking radiation may be completely different from that of the nonrotating case. In addition to the thermal effect of the temperature and the effective potential, which we considered in the previous section, new effects by the angular velocity are important in the rotating cases: in other words, superradiance.

B. Hawking radiation of rotating black holes

Here, we discuss the radiation from rotating dilatonic black holes when the black hole charge is conserved. Hereafter, we can assume that Q and J are positive with-

out loss of generality. The Klein-Gordon equation (2.5) for the neutral massless scalar field is separated into the spheroidal equation

$$\left[\frac{1}{\sin\theta} \frac{d}{d\theta} \left(\sin\theta \frac{d}{d\theta} \right) - \left\{ a^2 \omega^2 \sin^2\theta + \frac{m^2}{\sin^2\theta} \right\} \right] S(\theta) = -\lambda S(\theta) \quad (3.20)$$

and the radial equation

$$\left[\frac{d^2}{dr^{*2}} + [\omega - m\Omega(r)]^2 - V^2(r) \right] \chi(r^*) = 0, \quad (3.21)$$

by setting

$$\Phi = \frac{\chi(r^*)}{R(r)} S(\theta) e^{im\varphi} e^{-i\omega t}. \quad (3.22)$$

Here the tortoise coordinate r^* is defined by

$$dr^* \equiv \frac{R^2(r)}{\Delta(r)} dr. \quad (3.23)$$

The functions Ω , R , and V are defined for the Kerr-Newman black hole as

$$\Omega(r) \equiv (2Mr - Q^2) \frac{a}{R^4(r)}, \quad R^2(r) \equiv \Sigma|_{\theta=0} = r^2 + a^2,$$

$$V^2(r) \equiv \frac{\Delta(r)}{R^2(r)} \left\{ \frac{\lambda}{R^2(r)} + \frac{1}{R(r)} \frac{d}{dr} \left[\frac{\Delta(r)}{R^2(r)} \frac{dR(r)}{dr} \right] - \frac{m^2 a^2}{R^6(r)} (r^2 + a^2 - Q^2 + 2Mr) \right\}, \quad (3.24)$$

for the Kaluza-Klein black hole as

$$\Omega(r) \equiv \frac{2\mu r}{\sqrt{1-v^2}} \frac{a}{R^4(r)}, \quad R^2(r) \equiv B\Sigma|_{\theta=0} = (r^2 + a^2) \left(1 + \frac{v^2}{1-v^2} \frac{2\mu r}{r^2 + a^2} \right)^{\frac{1}{2}},$$

$$V^2(r) \equiv \frac{\Delta(r)}{R^2(r)} \left\{ \frac{\lambda}{R^2(r)} + \frac{1}{R(r)} \frac{d}{dr} \left[\frac{\Delta(r)}{R^2(r)} \frac{dR(r)}{dr} \right] - \frac{m^2 a^2}{R^6(r)} \left(r^2 + a^2 + \frac{2\mu r}{1-v^2} \right) \right\}, \quad (3.25)$$

and for the Sen black hole as

$$\Omega(r) \equiv 2\mu r \cosh^2 \beta \frac{a}{R^4(r)}, \quad R^2(r) \equiv \Sigma|_{\theta=0} = r^2 + a^2 + 2\mu r \sinh^2 \beta,$$

$$V^2(r) \equiv \frac{\Delta(r)}{R^2(r)} \left\{ \frac{\lambda}{R^2(r)} + \frac{1}{R(r)} \frac{d}{dr} \left[\frac{\Delta(r)}{R^2(r)} \frac{dR(r)}{dr} \right] - \frac{m^2 a^2}{R^6(r)} (r^2 + a^2 + 2\mu r \cosh 2\beta) \right\}. \quad (3.26)$$

The emission rates of energy and angular momentum [14] are given by

$$\frac{dM}{dt} = -\frac{1}{2\pi} \sum_{l,m} \int_0^\infty \frac{\omega (1 - |A|^2)}{\exp[(\omega - m\Omega_H)/T] - 1} d\omega,$$

$$\frac{dJ}{dt} = -\frac{1}{2\pi} \sum_{l,m} \int_0^\infty \frac{m (1 - |A|^2)}{\exp[(\omega - m\Omega_H)/T] - 1} d\omega. \quad (3.27)$$

The reflection coefficient $|A|^2$ is calculated by solving the wave equation (3.21) under the boundary condition

$$\begin{aligned} \chi &\rightarrow e^{-i\omega r^*} + A e^{i\omega r^*} & \text{as } r^* \rightarrow \infty, \\ \chi &\rightarrow B e^{-i\tilde{\omega} r^*} & \text{as } r^* \rightarrow -\infty, \end{aligned} \quad (3.28)$$

where $\tilde{\omega} \equiv \omega - m\Omega_H$. We integrate Eq. (3.27) by setting the upper bound of the integration as $\omega_{\max} = \max(25T, 1.5\Omega_H)$ for a rotating black hole. The eigenvalue λ of the spheroidal equation (3.20) is calculated perturbatively [15] as

$$\lambda = l(l+1) + \frac{1}{2} \left[\frac{(2m-1)(2m+1)}{(2l-1)(2l+3)} + 1 \right] a^2 \omega^2 + \frac{1}{2} \left[\frac{(l-m-1)(l-m)(l+m-1)(l+m)}{(2l-3)(2l-1)^3(2l+1)} - \frac{(l-m+1)(l-m+2)(l+m+1)(l+m+2)}{(2l+1)(2l+3)^3(2l+5)} \right] a^4 \omega^4 + O(a^6 \omega^6). \quad (3.29)$$

This approximation is valid, since $a\omega < 1$ and the coefficient of each term is small for all the cases we analyzed, although $\omega M > 1$ in some instances.

As we mentioned before, the coupling constant depen-

dence of the temperature or the angular velocity is remarkable in highly charged black holes. Hence we analyze such cases. If the black hole has a large charge, it carries only a small angular momentum, as is seen from

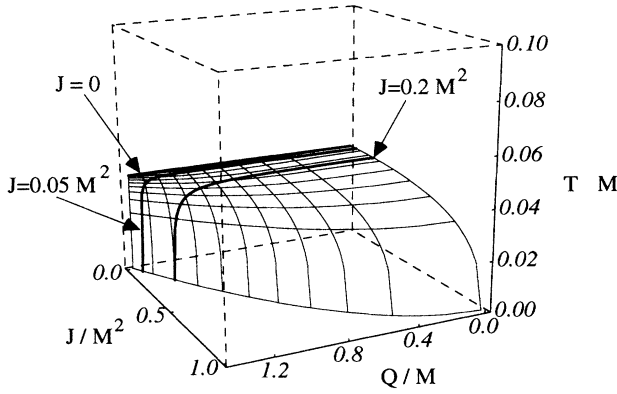

(a)

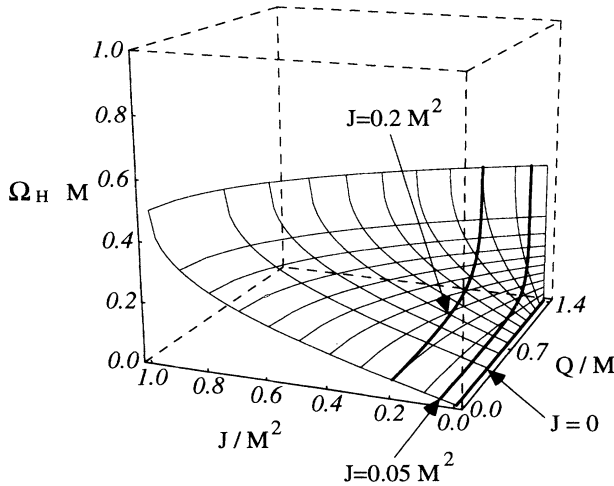

(b)

FIG. 4. The thermodynamical behavior of the Sen black hole. The same figures as Fig. 3 are depicted for the Sen black hole.

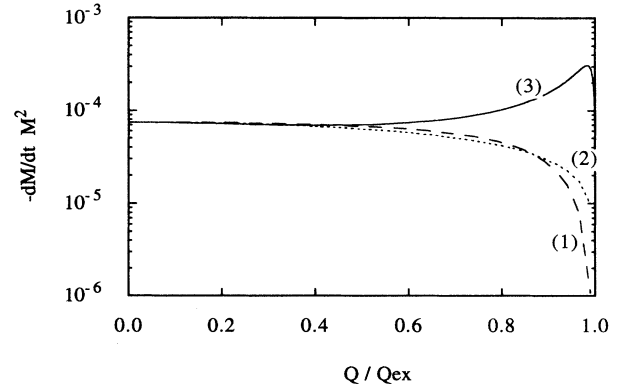

(a)

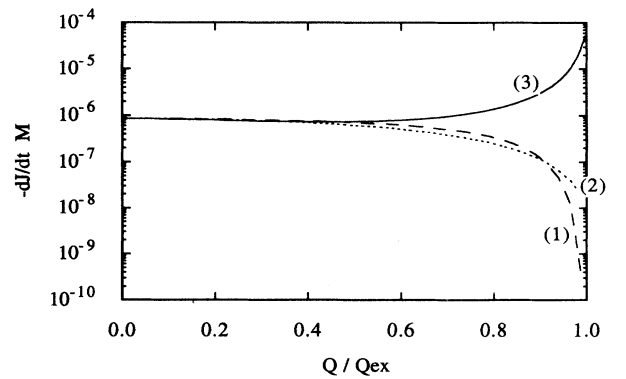

(b)

FIG. 5. The emission rate of (a) the energy $-dM/dt$ and (b) the angular momentum $-dJ/dt$ for three types of rotating black holes. Q is normalized by Q_{ex} . Each line corresponds to (1) the Kerr-Newman, (2) the Sen, and (3) the Kaluza-Klein black holes, respectively. Q_{ex} is $0.999 Q_{\text{max}}$, $0.995 Q_{\text{max}}$, and $0.972 Q_{\text{max}}$ for Kerr-Newman, for the Sen, and for the Kaluza-Klein black holes, respectively.

Fig. 2. Because of this, we consider the black holes with a small angular momentum, which is fixed at $J = 0.01M^2$, and vary the charge to see how the emission rates for each solution change in the extreme limit. The result is shown in Fig. 5. The charge is normalized by the maximal value Q_{ex} for the black hole with $J = 0.01M^2$, which is a little less than Q_{max} (see Fig. 2). The values of Q_{ex} are $0.999Q_{\text{max}}$, $0.995Q_{\text{max}}$, and $0.972Q_{\text{max}}$ for the Kerr-Newman, the Sen, and the Kaluza-Klein black holes, respectively. In Fig. 5, we see the Kaluza-Klein black hole radiates much more energy and angular momentum near the extreme limit than the Kerr-Newman and the Sen black holes. The behavior of the energy emission rates [Fig. 5 (a)] is very similar to that of nonrotating black holes, except in the vicinity of the extreme limit. This is because we have chosen a very small value for the angular momentum. However, in the Kaluza-Klein black hole, the emission rate drops a little near the extreme limit and does not diverge; so we find a different result from the nonrotating case. This is because the temperature of the rotating Kaluza-Klein black hole vanishes in the extreme limit whereas that of the nonrotating case is divergent in the same limit.

There appears to be a critical value of the dilaton

coupling constant at $\alpha \sim 1$, although we cannot give a definite critical value from our analysis of exact black hole solutions. However, there is another way to investigate such a critical value in the extreme limit. The temperatures of rotating black holes vanish in the extreme limit, and it is known that Hawking radiation becomes purely superradiant [16]; that is, the emission rates (3.27) are

$$\begin{aligned}\frac{dM}{dt} &= -\frac{1}{2\pi} \sum_{l,m} \int_0^{m\Omega_H} \omega (|A|^2 - 1) d\omega, \\ \frac{dJ}{dt} &= -\frac{1}{2\pi} \sum_{l,m} \int_0^{m\Omega_H} m (|A|^2 - 1) d\omega.\end{aligned}\quad (3.30)$$

In the previous paper [9], we analyzed superradiance of the rotating dilatonic black holes, which we will briefly summarize. To see how superradiance depends on the dilaton coupling constant, we considered the slowly rotating approximate solution with arbitrary coupling constant [7, 11], which is given by adding an angular momentum perturbation to the spherically symmetric solution (2.1), as well as the three exact solutions. This solution is expressed, in the same coordinates as the spherically symmetric solution in Sec. II, as

$$\begin{aligned}ds^2 &= -\frac{\Delta(\rho)}{R^2(\rho)} dt^2 + \frac{R^2(\rho)}{\Delta(\rho)} d\rho^2 + R^2(\rho)(d\theta^2 + \sin^2\theta d\varphi^2) - 2af(\rho)\sin^2\theta dt d\varphi, \\ A_t &= \frac{Q}{\rho}, \quad A_\varphi = -a\sin^2\theta \frac{Q}{\rho}, \quad \phi = \frac{\alpha}{1+\alpha^2} \ln\left(1 - \frac{\rho_-}{\rho}\right),\end{aligned}\quad (3.31)$$

where

$$\begin{aligned}\Delta(\rho) &\equiv (\rho - \rho_+)(\rho - \rho_-), \quad R(\rho) \equiv \rho \left(1 - \frac{\rho_-}{\rho}\right)^{\alpha^2/(1+\alpha^2)}, \\ f(\rho) &\equiv \frac{(1+\alpha^2)^2}{(1-\alpha^2)(1-3\alpha^2)} \left(\frac{\rho}{\rho_-}\right)^2 \left(1 - \frac{\rho_-}{\rho}\right)^{2\alpha^2/(1+\alpha^2)} - \left(1 - \frac{\rho_-}{\rho}\right)^{(1-\alpha^2)/(1+\alpha^2)} \\ &\quad \times \left[1 + \frac{(1+\alpha^2)^2}{(1-\alpha^2)(1-3\alpha^2)} \left(\frac{\rho}{\rho_-}\right)^2 + \frac{1+\alpha^2}{1-\alpha^2} \left(\frac{\rho}{\rho_-}\right) - \frac{\rho_+}{\rho}\right],\end{aligned}\quad (3.32)$$

and

$$\rho_{\pm} = \frac{(1+\alpha^2)[M \pm \sqrt{M^2 - (1-\alpha^2)Q^2}]}{(1 \pm \alpha^2)}, \quad a = \frac{2(1+\alpha^2)J}{(1+\alpha^2)\rho_+ + (1-\alpha^2/3)\rho_-}.\quad (3.33)$$

This solution is valid only when the parameter a is sufficiently small. Although $f(\rho)$ seems to diverge at $\alpha = 1/\sqrt{3}$, $\alpha = 1$, or $\rho_- = 0$, $f(\rho)$ approaches a finite limiting value when we expand this function around each point.

The Klein-Gordon equation is now separated into the Legendre equation and the radial equation

$$\left[\frac{d^2}{d\rho^{*2}} + [\omega - m\Omega(\rho)]^2 - V^2(\rho)\right] \chi(\rho^*) = 0, \quad (3.34)$$

where

$$\Omega(\rho) \equiv \frac{af(\rho)}{R^2(\rho)}, \quad (3.35)$$

$$V^2(\rho) \equiv \frac{\Delta(\rho)}{R^2(\rho)} \left[\frac{l(l+1)}{R^2(\rho)} + \frac{1}{R(\rho)} \frac{d}{d\rho} \left(\frac{\Delta(\rho)}{R^2(\rho)} \frac{dR(\rho)}{d\rho} \right) \right], \quad (3.36)$$

and ρ^* is defined by

$$d\rho^* \equiv \frac{R^2(\rho)}{\Delta(\rho)} d\rho. \quad (3.37)$$

The emission rates by superradiance for this approximate black hole solution are shown in Fig. 6, with the calculations using the three exact rotating black hole so-

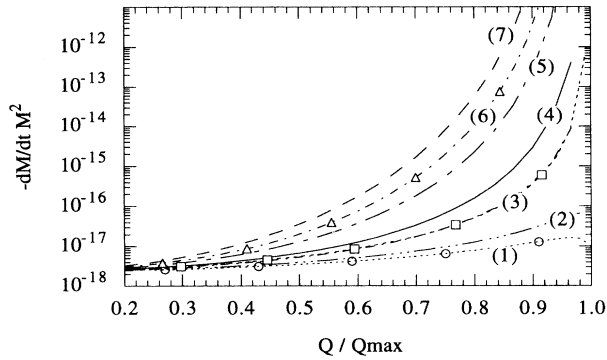

(a)

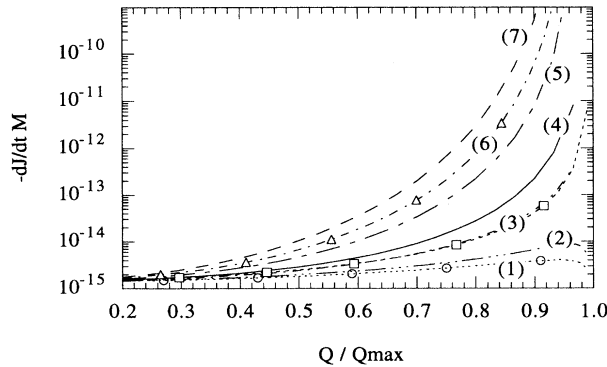

(b)

FIG. 6. Superradiance from slowly rotating black holes. (a) and (b) show the energy emission rate $-dM/dt$, and the angular momentum emission rate $-dJ/dt$, respectively. Each line corresponds to (1) $\alpha = 0$, (2) $\alpha = 0.5$, (3) $\alpha = 0.9$, (4) $\alpha = 1.1$, (5) $\alpha = 1.5$, (6) $\alpha = \sqrt{3}$, and (7) $\alpha = 2$. In addition, we plot the results for three exact solutions (the circles for the Kerr-Newman, the squares for the Sen, and the triangles for the Kaluza-Klein black holes). The charge is normalized by Q_{\max} .

lutions. We find that the emission rate from the large coupling constant black holes blows up as the black hole approaches the extreme one, whereas with small α , the emission rate remains quite small. These two types of behavior are divided by a value of the coupling constant of about unity.

Again we cannot determine the exact value of the critical coupling constant, for the following reason. As we mentioned before, this approximate black hole solution is valid only when the angular momentum is sufficiently small. In addition to this condition, there is another requirement that must be satisfied, namely, that the black hole charge should not be so large. This is found by observing that the maximally charged black hole ($Q = Q_{\max}$) in the approximate solution can carry an angular momentum, while the exact solution cannot (e.g., consider the Kerr-Newman black hole). Quantitatively, the angular velocity $\Omega_H \equiv \Omega(\rho_+)$ of the black hole is divergent in the extreme limit for $\alpha \geq 1/\sqrt{3}$ and vanishes for smaller coupling constants, but this critical value is derived from the approximate solution and may differ from the value of the exact solution, which we do not know. In fact, the angular velocity in the extreme limit of the Sen black hole, which is a solution of the model (1.2) ($\alpha = 1$), is finite and nonzero, although this solution is obtained from a different action from the Kerr-Newman and the Kaluza-Klein black holes. The qualitative behavior of the angular velocity in the approximate solution seems to follow that of the exact solution closely, although that of the temperature does not. Hence we may give a qualitative discussion of superradiance by using this approximate solution.

We may conclude from the above that the critical coupling constant at which the behavior of the superradiant emission changes exists and is about unity. As we have already shown, the behavior of the emission rate by thermal radiation from the nonrotating black hole also changes at $\alpha = 1$. Naively speaking, Hawking radiation for the rotating black hole consists of two components, that is, thermal radiation and superradiance. So we naturally expect that the emission of Hawking radiation from rotating black holes is drastically changed at $\alpha \sim 1$.

C. Fate of dilatonic black holes

The dependence of the emission on the coupling constant leads to a difference in the evolution of black holes by evaporation. To investigate the evolution of the three exact rotating solutions above, we describe the black hole state by a pair of quantities $(Q/M, J/M^2)$, and analyze their time variations, which are given by the emission rates as

$$\frac{d}{dt} \left(\frac{Q}{M} \right) = - \frac{Q}{M^2} \frac{dM}{dt}, \quad (3.38)$$

$$\frac{d}{dt} \left(\frac{J}{M^2} \right) = \frac{1}{M^2} \frac{dJ}{dt} - 2 \frac{J}{M^3} \frac{dM}{dt}, \quad (3.39)$$

for the three exact black hole solutions. We recognize these two quantities as a vector field on the Q/M - J/M^2 plane shown in Fig. 2, and show it in Fig. 7. Since we

assume that the black hole charge is conserved, and the black holes lose mass energy, Eq. (3.38) is always positive; so Q/M increases and the black hole approaches the extreme state. In Fig. 7, near the extreme lines, each vector points to a direction inside the extreme line; so the black hole does not evolve beyond the extreme line and eventually approaches the $Q = Q_{\max}$ state. From the figure, we can see that the Kerr-Newman black hole stops its evolution as it approaches $Q = Q_{\max}$ whereas the evolution of the Kaluza-Klein black hole is accelerated as Q/M increases, and in particular, the evolution is very fast near $Q = Q_{\max}$. This is because the emission rates of the Kaluza-Klein black hole near $Q = Q_{\max}$ state are very large. As we mentioned before, the $Q = Q_{\max}$ state is not a black hole solution and a naked singularity appears at this point. So it is indicated from our analysis that the Kaluza-Klein black hole evolves rapidly into a naked singularity. As we have already seen, the area

of the Kaluza-Klein black hole vanishes as $Q \rightarrow Q_{\max}$. This situation is quite similar to the evaporation of the Schwarzschild black hole, for which the area of the black hole vanishes and the emission rate increases infinitely large in the final stage, where a naked singularity might appear. The Sen black hole shows an intermediate behavior between that of the Kerr-Newman and the Kaluza-Klein black holes.

IV. DISCHARGE OF DILATONIC BLACK HOLES BY SUPERRADIANCE

So far, we have considered only the case where the charge of the black hole is conserved. Usually, however, black holes may create charged particles and lose their charge. In this section we study the discharge process by superradiance of a charged scalar field described by the equation of motion

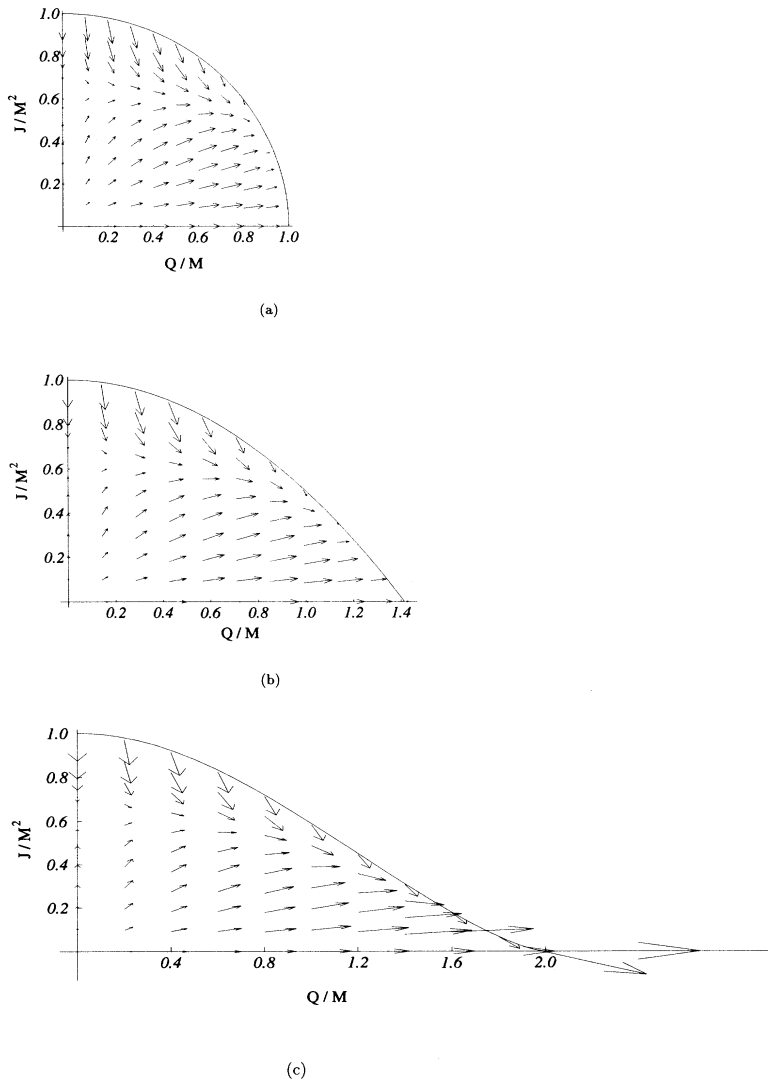

FIG. 7. The evolution of three types of black hole. Each figure represents (a) the Kerr-Newman, (b) the Sen, and (c) the Kaluza-Klein black holes. The arrow shows the direction and magnitude of the evolution of the black hole by Hawking evaporation at each point. The scale of the arrow is enlarged 2500 times. Although the arrows near $Q = Q_{\max}$ are very small for the Kerr-Newman and the Sen black holes, those in the Kaluza-Klein black hole are considerably larger.

$$[(\nabla^\mu + ieA^\mu)(\nabla_\mu + ieA_\mu) - \mu^2] \Phi = 0, \quad (4.1)$$

where e and μ are the charge and the rest mass of the particle, respectively. Shiraishi [13] analyzed superradiance of a charged scalar field Φ coupled to the dilaton ϕ in the spherically symmetric dilatonic black hole. Here we do not consider such a coupling because we are only interested in the pure quantum properties of the dilatonic black hole, but not the extra effects on the quantum radiation, which come from a direct coupling between Φ and the dilaton field.

The time scales of the loss of energy, angular momentum, and charge depend on the temperature T , the angular velocity Ω_H , and the electric potential Φ_H in the Planck distribution of Hawking radiation as

$$\frac{1}{\exp[(\omega - m\Omega_H - e\Phi_H)/T]}. \quad (4.2)$$

If the electric potential is large enough compared with the temperature and the angular velocity, the dominant component of the emission is that of the superradiant discharge process. In order to estimate how important the discharge process is in Hawking radiation, we calculate the superradiant emission rates in a spherically symmetric dilatonic black hole, in which the electric potential Φ_H is

$$\Phi_H = \frac{Q}{\rho_+}. \quad (4.3)$$

The horizon radius ρ_+ is given by Eq. (2.3). If superradiance is large compared to the emission calculated in the previous sections, where we assumed that the charge is conserved, the discharge process is important and should not be ignored, while, if it is small, the discharge process is not essential in Hawking radiation.

The emission rates are

$$\frac{dM}{dt} = -\frac{1}{2\pi} \sum_{l,m,e} \int_{\mu}^{e\Phi_H} \omega (|A|^2 - 1) d\omega, \quad (4.4)$$

$$\frac{dQ}{dt} = -\frac{1}{2\pi} \sum_{l,m,e} \int_{\mu}^{e\Phi_H} e (|A|^2 - 1) d\omega, \quad (4.5)$$

where the reflection coefficient $|A|^2$ is obtained by solving the radial wave equation

$$\left[\frac{d^2}{d\rho^{*2}} + \left(\omega - e \frac{Q}{\rho} \right)^2 - \mu^2 \frac{\Delta(\rho)}{R^2(\rho)} - V^2(\rho) \right] \chi(\rho^*) = 0, \quad (4.6)$$

which is derived by setting in the same way as Eq. (2.7), under the boundary condition of

$$\begin{aligned} \chi &\rightarrow e^{-i\omega\rho^*} + Ae^{i\omega\rho^*} & \text{as } \rho^* \rightarrow \infty, \\ \chi &\rightarrow Be^{-i\tilde{\omega}\rho^*} & \text{as } \rho^* \rightarrow -\infty, \end{aligned} \quad (4.7)$$

where $\tilde{\omega}$ is now defined as $\tilde{\omega} = \omega - e\Phi_H$, and the tortoise coordinate ρ^* , functions $R(\rho)$ and $\Delta(\rho)$, and the potential V^2 are the same as those in Sec. II. Here we consider

only the dominant mode of $l = 0$.

The wave equation (4.6) is not invariant under rescaling by the black hole mass M , in contrast to the case of the massless field considered in the previous sections. The first and the last terms in the square brackets in Eq. (4.6) are roughly proportional to M^{-2} , whereas the second and the third terms are independent of the mass scale. This results in that the transmission probability $|A|^2 - 1$ depends explicitly on the mass of the black hole. Hence we have to calculate the emission rates for each mass scale and analyze the mass dependence of the emission, in addition to the coupling constant dependence.

First we consider the Planck mass black hole ($M = M_{\text{Pl}}$). We show the emission rates in Fig. 8 for four values of the coupling constant: $\alpha = 0, 0.5, 1, 1.5$. Q is now normalized by the mass of the black hole M , but not Q_{max} , because Q itself is essential in this process, but not Q/Q_{max} . We set the particle mass $\mu = 0.001M_{\text{Pl}}$. From

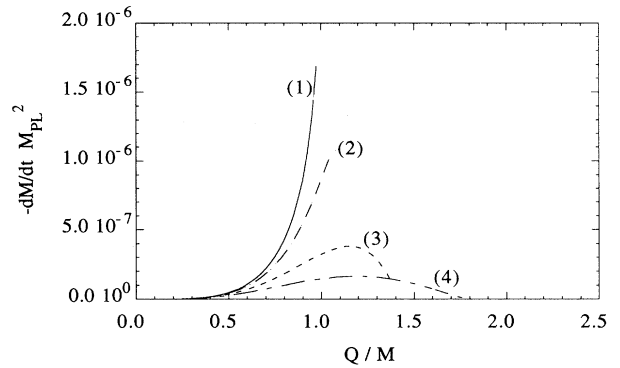

(a)

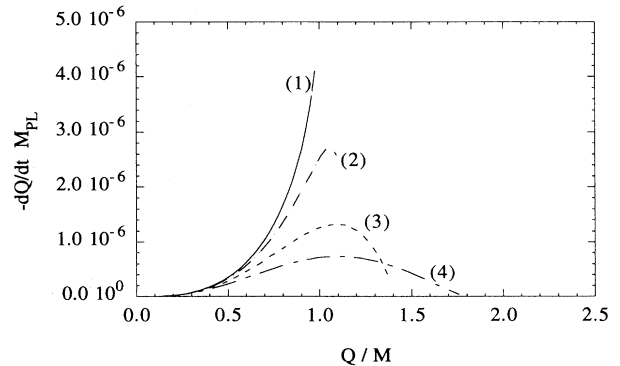

(b)

FIG. 8. Discharge by superradiance from nonrotating black holes with mass $M = M_{\text{Pl}}$. (a) and (b) show the energy emission rate $-dM/dt$ and the charge emission rate $-dQ/dt$ normalized by the Planck mass M_{Pl} , respectively. Each line corresponds to (1) $\alpha = 0$, (2) $\alpha = 0.5$, (3) $\alpha = 1$, and (4) $\alpha = 1.5$.

this figure, we find that the emission rates are greater in the black hole with the smaller coupling constant, in contrast to the results of the previous two sections. In particular, emission from the highly charged black hole with larger coupling constant is very small. There are two reasons for this. One is the behavior of the electric potential Φ_H . From Eq. (4.3), we can see the electric potential becomes smaller when the coupling constant α increases. The second reason is that the effective potential in Eq. (4.6) is very high near the extreme limit for the black hole with $\alpha > 1$ and the transmission probability becomes much smaller, as in the previous cases.

Now we analyze the dependence of the emission rates on the mass of the black hole. To see how the emission rate changes, we calculate the case of $M = 10M_{\text{Pl}}$ and show the result in Fig. 9. Comparison with Fig. 8 shows that the emission rates generally increase when the mass increases. This tendency is clearer in the highly charged

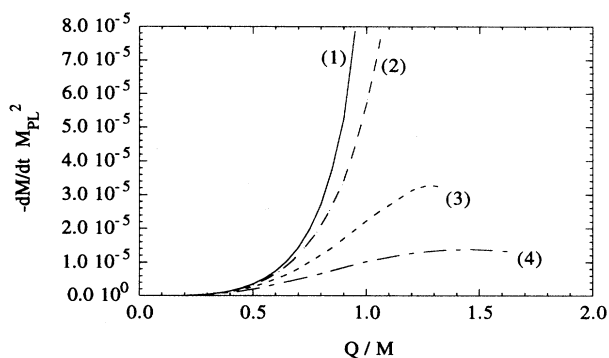

(a)

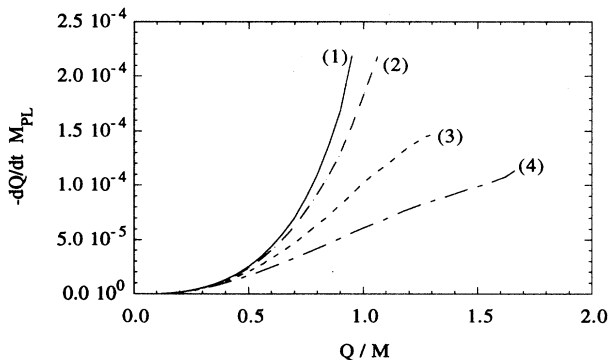

(b)

FIG. 9. Discharge by superradiance from nonrotating black holes with mass $M = 10M_{\text{Pl}}$. (a) and (b) show the energy emission rate $-dM/dt$ and the charge emission rate $-dQ/dt$, respectively. Each line corresponds to (1) $\alpha = 0$, (2) $\alpha = 0.5$, (3) $\alpha = 1$, and (4) $\alpha = 1.5$.

black holes with a larger coupling constant. The dependence on the coupling constant is smaller than the case of $M = M_{\text{Pl}}$. This is because the height of the effective potential, which is roughly proportional to M^{-2} , is effectively lower than that in the case of a Planck mass black hole. In particular, the emission of a highly charged black hole with large mass becomes insensitive to the coupling constant because the potential barrier gets small, compared with the case of a Planck-mass-scale black hole where the potential is very high for the large coupling constant and the emission is suppressed near the extreme limit. Consequently, we expect that the coupling constant dependence of the emission rate will become smaller as we increase the mass of the black hole.

For a black hole larger than $10M_{\text{Pl}}$, the numerical calculation becomes difficult because we have to deal with a very large scale black hole and a very small scale particle simultaneously. Fortunately, for a massive black hole with small charge, the V^2 term in Eq. (4.6) is very small and can be neglected. Furthermore, the rest of the potential terms (the second and the third terms in the square brackets) in Eq. (4.6) vary very slowly; so we can use the WKB approximation to calculate the transmission probabilities, as in Refs. [13, 17].

When the black hole mass M is sufficiently large and Q/M is small, the radial wave equation (4.6) is approximated by

$$\left[\frac{d^2}{d\rho^{*2}} + \left(\omega - e \frac{Q}{\rho} \right)^2 - \mu^2 \frac{\Delta(\rho)}{R^2(\rho)} \right] \chi(\rho^*) = 0, \quad (4.8)$$

and the transmission probability $|A|^2 - 1$ can be estimated from

$$\begin{aligned} |A|^2 - 1 &= \exp \left[-2 \int_{\rho_1^*}^{\rho_2^*} \sqrt{|W|} d\rho^* \right] \\ &= \exp \left[-2 \int_{\rho_1}^{\rho_2} \sqrt{|W|} \frac{R^2}{\Delta} d\rho \right], \end{aligned} \quad (4.9)$$

where

$$W = \left(\omega - e \frac{Q}{\rho} \right)^2 - \mu^2 \frac{\Delta(\rho)}{R^2(\rho)}, \quad (4.10)$$

and ρ_1^* and ρ_2^* ($\rho_1^* < \rho_2^*$) are the corresponding tortoise coordinates to two roots ρ_1, ρ_2 of $W(\rho) = 0$.

In the $\alpha = 0$ case, in which the black hole is described by the Reissner-Nordström solution and

$$W = \left(\omega - e \frac{Q}{\rho} \right)^2 - \mu^2 \left(1 - \frac{2M}{\rho} + \frac{Q^2}{\rho^2} \right), \quad (4.11)$$

Eq. (4.9) is integrated, giving

$$|A|^2 - 1 = \exp \left[-2\pi\mu^2 \frac{eQ - (\omega - k)M}{k(\omega + k)} \right], \quad (4.12)$$

where

$$k \equiv \sqrt{\omega^2 - \mu^2}. \quad (4.13)$$

From this, we find Schwinger's formula for the emission

rate dQ/dt :

$$\frac{dQ}{dt} \sim -\frac{e^4 Q^3}{\rho_+} \exp\left[-\frac{\pi\mu^2 \rho_+^2}{eQ}\right] \quad (4.14)$$

in the small charge limit [17].

We can also explicitly calculate the transmission probability in the superstring case ($\alpha = 1$), in which

$$W = \left(\omega - e\frac{Q}{\rho}\right)^2 - \mu^2 \left(1 - \frac{\rho_+}{\rho}\right). \quad (4.15)$$

It gives exactly the same result as Eq. (4.12). In addition, for the case of small charged black holes with an arbitrary coupling constant, we can use the approximation

$$\frac{Q}{Q_{\max}} \ll 1, \quad (4.16)$$

and so $\rho_+ \gg \rho_-$; then

$$\begin{aligned} \frac{\Delta(\rho)}{R^2(\rho)} &= \left(1 - \frac{\rho_+}{\rho}\right) \left(1 - \frac{\rho_-}{\rho}\right)^{(1-\alpha^2)/(1+\alpha^2)} \\ &\sim \left(1 - \frac{\rho_+}{\rho}\right) \left(1 - \frac{\tilde{\rho}_-}{\rho}\right), \end{aligned} \quad (4.17)$$

where

$$\tilde{\rho}_- \equiv \frac{1 - \alpha^2}{1 + \alpha^2} \rho_-, \quad (4.18)$$

and we find the same transmission probability as Eq. (4.12). Hence, for the dilatonic black hole with a fixed mass and charge, the transmission probability of the particle with the same energy is hardly influenced by the coupling constant. As for the total emission rate, the black hole with the larger coupling constant emits a little bit less energy, because the energy range of the superradiant modes, i.e., $\mu \leq \omega \leq e\Phi_H$, becomes narrow as the coupling constant increases. When the charge of the black hole increases, the emission rate increases. In the extreme limit, the black hole with larger coupling constant can carry a larger charge. Hence we may expect that the nearly extreme black hole with a larger coupling constant emits larger energy than that with a smaller coupling constant. However, near the extreme limit for $\alpha > 1$, the WKB approximation breaks down and the effective potential becomes very steep. As a result, emission may not increase so much. So we expect that the dependence of the emission on the coupling constant becomes smaller for a more massive black hole. This has been confirmed by our numerical calculations.

V. CONCLUSION AND DISCUSSION

In summary, we first studied the evaporation of dilatonic black holes under the assumption that the black hole charge is conserved, and analyzed its dependence on the dilaton coupling constant. We found that the emission rate of the nonrotating black hole changes drastically at $\alpha = 1$, which is the value predicted by superstring theory. In the case of the coupling constant below unity, the

emission rate vanishes in the extreme limit, while the black hole with $\alpha > 1$ emits a large amount of energy in the same limit, even though the potential barrier becomes infinitely high in this case. This means the effect of the temperature on the emission is stronger than that of the potential barrier.

As for rotating black holes, the temperature is zero for the extreme black holes and the thermal emission also vanishes for all known exact black hole solutions. However, in the maximally charged limit $Q \rightarrow Q_{\max}$ of the Kaluza-Klein black hole, while the angular momentum itself is still small, the angular velocity of the black hole becomes very large and the effect of superradiance becomes important. In superradiance, we also find the critical value of the coupling constant $\alpha \sim 1$, above which the emission rate increases rapidly as the black hole approaches the maximally charged state. Therefore, we may reasonably conclude that $\alpha \sim 1$ is the critical coupling constant together with the thermal component of the quantum radiation.

As a result, a highly charged Kaluza-Klein black hole ($\alpha = \sqrt{3}$) is inevitably accelerated towards evaporation into a naked singularity. This situation is very similar to the final stage of the evaporation of the Schwarzschild black hole where the emission blows up and the area of the black hole vanishes. We expect that black holes with $\alpha > 1$ show a similar evaporation process to the Kaluza-Klein case, since the emission rates for such black holes are very large in the maximally charged limit.

We have also considered the discharge process by calculating superradiance for nonrotating dilatonic black holes. If the mass of the black hole is on the Planck scale, the emission is suppressed for large coupling constants, compared with the Reissner-Nordström black hole ($\alpha = 0$), especially near the extreme limit. Hence, the effect of the discharge may not be so important for highly charged black holes with $\alpha > 1$. As the mass of the black hole increases, however, the dependence of the emission on the coupling constant becomes small and a black hole with any α will discharge efficiently.

Holzhey and Wilczek [6] pointed out that, in the maximally charged limit of the dilatonic black holes, the thermodynamical interpretation breaks down. The solution of the maximally charged limit represents a naked singularity, and the higher order quantum effects will become important near this limit. This means that the black hole thermodynamics may deviate from the conventional approach, which is based on the semiclassical treatment of Hawking radiation. We should make some comments on this point. The problems related to this paper are the following. (1) The emission rate becomes very large; so we have to consider the back reaction of the quantum effects on the metric. (2) The area of the black hole vanishes in the maximally charged limit, which means we have to deal with a horizon radius smaller than the Planck scale. (3) To clarify the coupling constant dependence, we discuss the Planck-mass-scale black hole. In order to study such problems properly, we may need quantum gravity. However, before investigating the full quantum theory, we first have to clarify the behavior in the semiclassical regime.

ACKNOWLEDGMENTS

We would like to thank R. Easter for reading the paper carefully. This work was supported partially by a

Grant-in-Aid for Scientific Research Fund of the Ministry of Education, Science and Culture (No. 06302021 and No. 06640412), and by a Waseda University Grant for Special Research Projects.

-
- [1] C. G. Callan, D. Friedan, E. J. Martinec, and M. J. Perry, Nucl. Phys. **B262**, 593 (1985).
 - [2] G. W. Gibbons and K. Maeda, Nucl. Phys. **B298**, 741 (1988).
 - [3] K. Maeda, Phys. Rev. D **35**, 471 (1987); G. Veneziano, Phys. Lett. B **265**, 287 (1991); D. S. Goldwirth and M. J. Perry, Phys. Rev. D **49**, 5019 (1994); E. J. Copeland, A. Lahiri, and D. Wands, *ibid.* **50**, 4868 (1994); A. A. Tseytlin, Int. J. Mod. Phys. D **1**, 223 (1992); I. Antoniadis, J. Rizos, and K. Tamvakis, Nucl. Phys. **B415**, 497 (1994); T. Damour and A. Vilenkin, Report No. IHES/P/95/26 (unpublished).
 - [4] We use units of $c = \hbar = G = k_B = 1$.
 - [5] D. Garfinkle, G. T. Horowitz, and A. Strominger, Phys. Rev. D **43**, 3140 (1991).
 - [6] C. F. E. Holzhey and F. Wilczek, Nucl. Phys. **B380**, 447 (1992).
 - [7] J. H. Horne and G. T. Horowitz, Phys. Rev. D **46**, 1340 (1992).
 - [8] A. Sen, Phys. Rev. Lett. **69**, 1006 (1992).
 - [9] J. Koga and K. Maeda, Phys. Lett. B **340**, 29 (1994).
 - [10] V. Frolov, A. Zelnikov, and U. Bleyer, Ann. Phys. (Leipzig) **44**, 371 (1987).
 - [11] K. Shiraishi, Phys. Lett. A **166**, 298 (1992).
 - [12] G. W. Gibbons and D. L. Wiltshire, Ann. Phys. (N.Y.) **167**, 201 (1986).
 - [13] The coupling of dilaton with a scalar field may change our results. For example, Shiraishi analyzed the superradiant discharge process of such a scalar field in the spherically symmetric dilatonic black hole and showed that the emission rate is enhanced when α increases, due to the coupling between dilaton and scalar field, in contrast to our results. See K. Shiraishi, Mod. Phys. Lett. A **7**, 3449 (1992).
 - [14] S. W. Hawking, Commun. Math. Phys. **43**, 199 (1975).
 - [15] C. J. Bouwkamp, Phillips Res. Rep. **5**, 87 (1950).
 - [16] W. G. Unruh, Phys. Rev. D **10**, 3194 (1974).
 - [17] G. W. Gibbons, Commun. Math. Phys. **44**, 245 (1975).