

Quark exchange in nuclei and the European Muon Collaboration effect

Pervez Hoodbhoy*

Physics Department, Carnegie-Mellon University, Pittsburgh, Pennsylvania 15213

R. L. Jaffe

*Center for Theoretical Physics, Laboratory for Nuclear Science and Department of Physics,
Massachusetts Institute of Technology, Cambridge, Massachusetts 02139*

(Received 2 September 1986)

Quark exchange between nucleons bound in a nucleus can cause a shift in the momentum distribution of quarks relative to free nucleons. This is true even if nucleon properties, including size, remain unchanged in the nuclear environment. This shift in momentum leads to a contribution to the matrix elements of single-quark operators which is nonadditive, and therefore cannot be incorporated into a convolution model. For $A=3$ nuclei investigated here, such exchange contributions were found to be important, perhaps even dominant, in calculating the deviation from unity of the ratio of the nuclear structure function to that of the free nucleon (European Muon Collaboration ratio).

INTRODUCTION

It is intuitively appealing to regard deep-inelastic lepton scattering from nuclei as a two-step process. First, the nuclear wave function is decomposed into some basis of constituents, nucleons in the first instance, nucleons and pions in more elaborate schemes, and later perhaps including more exotic objects such as Δ 's, multiquark conglomerates, and so on. Then the structure functions of the constituents are added incoherently to give the structure function of the whole nucleus. This is the "convolution model" often used in analyses of the European Muon Collaboration (EMC) effect.¹⁻³ A detailed discussion of the assumptions, and possible flaws, of the model are given in Ref. 4.

In addition to the incoherent processes with which the convolution model deals, there could exist coherent ones arising, for instance, from quark exchange between nucleons. Coherent processes are not suppressed by powers or even logarithms of Q^2 . Their importance is a dynamical issue, which has yet to be seriously addressed. Quark-exchange contributions to the nuclear structure function arise because quarks in different nucleons must be antisymmetrized. This has been explicitly demonstrated in a simple, solvable one-dimensional model,⁵ the essence of which will be repeated later for clarity.⁶ In Ref. 5 it was shown that the scale of these effects is set by the ratio of the nucleon size to the typical internucleon separation in nuclei. Furthermore, the effect of quark exchange between nucleons is to soften the quark momentum distribution in nuclei (it increases the correlation length), which is the major component of the EMC effect. Of course, one cannot conclude anything quantitative from a toy one-dimensional model. In this paper we perform a realistic calculation in three dimensions with actual nuclear wave functions. We choose the $A=3$ system (${}^3\text{He}, {}^3\text{H}$) for several reasons. First, for $A=2,3$ nuclei one has presumably the most reliable nuclear wave functions, since the

nonrelativistic two- or three-nucleon problem with phenomenologically determined nucleon-nucleon potentials can be solved exactly. This is an important consideration since one expects quark exchange (somewhat like heavy-meson exchange) to be a short-range process depending rather strongly on nucleon-nucleon correlations. Second, the smaller A is, the more tractable the calculation. Finally, we discard the deuteron because it is anomalously diffuse. Quark-exchange effects can be expected to grow with nuclear density. Since ${}^3\text{He}$ and ${}^3\text{H}$ have densities not far removed from heavy matter they can be expected to manifest EMC-type effects which can be extrapolated smoothly to arbitrary A .

We do not claim that quark exchange between nucleons is the only coherent effect which must be added to the convolution approach. Final-state interactions, vertex corrections, and many other effects may also be important. In addition there are other, independent, difficulties with the convolution model discussed in Ref. 4. Nevertheless, quark-exchange effects must be present, and it comes as a surprise that they are of the same magnitude and shape as the EMC effect.

With a view towards presenting the essential physics with maximum clarity, the one-dimensional model first presented in Ref. 5 is repeated with only minor modifications in Sec. I. Subsequently, in Secs. II and III the formalism is developed for calculating the quark momentum distribution in $A=3$ nuclei. The distribution is a sum of direct and exchange parts. Section IV is concerned with the relation between the deep-inelastic structure function and this momentum distribution, and with the expected EMC effect in the unpolarized isoscalar $A=3$ system. Finally, a discussion in Sec. V of the results and approximations used concludes the paper.

I. A TOY MODEL (Ref. 5)

Instead of proceeding straightaway with the actual nuclear calculation, the essential physics will be elucidated

here by means of a simple toy model. Consider a one-dimensional “nucleus” made of two “pions,” each of which in turn is made of a quark and antiquark. The quarks are spinless fermions (this being one dimension) $b^\dagger(k)$ [$d^\dagger(k)$] creates a quark [antiquark] with momentum k . The relation between the quark momentum and its energy will be left unspecified since there is no adequate treatment of the relativistic bound state. This is not a problem: Fermi statistics, not the kinematics, are the essence of the physics. The pion state is

$$|\pi(P)\rangle = \int dk \phi_\pi(k) b^\dagger(P/2+k) d^\dagger(P/2-k) |0\rangle. \quad (1.1)$$

The normalization $\langle \pi(P) | \pi(P') \rangle = \delta(P-P')$ fixes $\int dk |\phi_\pi(k)|^2 = 1$. Now let us construct the “nucleus” from two pions:

$$|\pi\pi(K)\rangle = \frac{1}{\sqrt{2!}} \int dP \chi_{\pi\pi}(P) |\pi(K/2+P)\pi(K/2-P)\rangle. \quad (1.2)$$

This state is a composite constructed from elementary constituents obeying definite statistics and is, in this sense, similar to a nucleus comprised of quarks. The “nuclear” state is not normalized to unity. Instead, choosing $\int dP |\chi_{\pi\pi}(P)|^2 = 1$, a straightforward calculation yields an expression for the normalization in terms of the “pion”

$$[A(P), A^\dagger(P')] = \delta(P-P') - C(P, P'), \quad (1.8)$$

$$C(P, P') = \int dk dk' \phi^*(k') \phi(k) [\delta(P'/2 - P/2 + k' - k) d^\dagger(P/2 - k) d(P'/2 - k') + \delta(P'/2 - P/2 - k' + k) b^\dagger(P/2 + k) b(P'/2 + k')]. \quad (1.9)$$

Notice that $C(P, P')$ is zero only when the pion wave functions do not overlap. The fact that composites do not always obey simple Bose or Fermi statistics was, of course, recognized in the early days of quantum mechanics and is the subject of the well-known Ehrenfest-Oppenheimer theorem.⁷

To proceed with the simple model defined in Eqs. (1.1) and (1.2), the momentum distribution of quarks in the nuclear rest frame can be calculated:

$$\begin{aligned} \rho(k) &= \frac{\langle \pi\pi(K=0) | b^\dagger(k) b(k) | \pi\pi(K=0) \rangle}{\langle \pi\pi(K=0) | \pi\pi(K=0) \rangle} \\ &= \frac{\rho_{\text{dir}}(k) - \rho_{\text{exch}}(k)}{1 - E}, \end{aligned} \quad (1.10)$$

where the direct and exchange terms are

$$\rho_{\text{dir}}(k) = \int dk' dP \delta(k - k' - P/2) |\chi_{\pi\pi}(P)|^2 |\phi_\pi(k')|^2, \quad (1.11)$$

$$\begin{aligned} \rho_{\text{exch}}(k) &= \int dk' dk'' dP \delta(k - k' - P/2) \\ &\quad \times \chi_{\pi\pi}^*(P) \chi_{\pi\pi}(Q) \phi_\pi^*(q - Q/2) \\ &\quad \times \phi_\pi^*(q + Q/2) \phi_\pi(q + P/2) \phi_\pi(q - P/2), \end{aligned} \quad (1.12)$$

wave function ϕ_π and the “nuclear” wave function $\chi_{\pi\pi}$:

$$\langle \pi\pi(K) | \pi\pi(K') \rangle = (1 - E) \delta(K - K'), \quad (1.3)$$

$$E = \int dy |\psi(y)|^2, \quad (1.4)$$

$$\psi(y) = \int dz \tilde{\chi}_{\pi\pi}^*(z) \tilde{\phi}_\pi(z + y/2) \tilde{\phi}_\pi(-z + y/2), \quad (1.5)$$

$\tilde{\chi}_{\pi\pi}$ and $\tilde{\phi}_\pi$ are coordinate-space wave functions, the Fourier transforms of $\chi_{\pi\pi}$ and ϕ_π . A little thought will convince the reader that E measures the probability for a quark in one pion to be on top of a quark in the other. It vanishes as the nuclear density goes to zero, but is certainly present at finite density.

It is useful to look at the origin of the exchange correction from yet another angle. The pion states from which the nuclear state is constructed do not form an orthogonal basis. To see this, define $A^\dagger(P)$ to be the creation operator for a pion with momentum P .

$$|\pi(P)\rangle = A^\dagger(P) |0\rangle \quad (1.6)$$

with

$$A^\dagger(P) = \int dk \phi_\pi(k) b^\dagger(P/2+k) d^\dagger(P/2-k). \quad (1.7)$$

Naively one might think that $A^\dagger(P)$ obeys the usual commutation relation for bosons. This is indeed correct for *point* pions; however, an easy calculation shows that

where $Q = k' - k''$ and $q = (k' + k'')/2$. The direct term above is a convolution of the motion of a quark in a pion with that of the overall motion of the pion in the nucleus (“Fermi motion”). The exchange term cannot be written as a convolution. It originates from the fact that $C(P, P') \neq 0$ in Eq. (1.9). One may verify that

$$\int dk \rho(k) = 2, \quad (1.13)$$

as required by quark-number conservation

The structure function of deep-inelastic electron scattering measures the distribution of quarks as a function of $k^+ = (k^0 + k)/\sqrt{2}$ in the nucleus’ rest frame. The k^+ distribution cannot be calculated from $\rho(k)$ without making some assumptions about the Hamiltonian which binds the quarks in “pions” and the “pions” in the “nucleus.” This subject is deferred until Sec. IV. Here it is sufficient to note that the exchange part of $\rho(k)$ will generate a corresponding exchange contribution to the deep-inelastic structure function. While it is true that this should vanish as the nuclear density goes to zero, so do the EMC effect and other density-dependent phenomena.

II. NOTATION AND FORMULATION

The trinucleon system considered in this section involves many more degrees of freedom than the one-

dimensional model considered earlier. It is therefore convenient to introduce an abbreviated notation. We shall designate the coordinates of a nucleon collectively by the symbols α or β (with subscripts $i=1,2,3$):

$$\alpha, \beta = \{ \mathbf{p}, M_S, M_T \}, \quad (2.1)$$

\mathbf{p} is the nucleon's momentum, and M_S, M_T are the third components of its spin and isospin. The coordinates of a quark are collectively designated by μ, ν, ρ , or σ (also with subscripts $i=1,2,3$):

$$\mu, \nu, \rho, \sigma = \{ \mathbf{k}, m_s, m_t, c \}, \quad (2.2)$$

\mathbf{k}, m_s, m_t, c denote the quark momentum, third components of spin and isospin, and color, respectively. To

$$C_{\mu_1 \mu_2 \mu_3}^\alpha = \frac{1}{\sqrt{3!}} \epsilon_{c_1 c_2 c_3} \frac{1}{\sqrt{2}} \sum_{s=t=0,1} C_{m_s m_s M_S}^{1/2s} C_{m_s m_s m_s}^{1/21/21/2s} C_{m_t m_t M_T}^{1/2t} C_{m_t m_t m_t}^{1/21/21/2t} \int d\mathbf{k}_1 d\mathbf{k}_2 d\mathbf{k}_3 \delta(\mathbf{k}_1 + \mathbf{k}_2 + \mathbf{k}_3 - \mathbf{p}) \phi(\mathbf{k}_1, \mathbf{k}_2, \mathbf{k}_3, \mathbf{p}). \quad (2.4)$$

The normalization of ϕ is chosen so that

$$\langle \mathbf{p} M_S M_T | \mathbf{p}' M'_S M'_T \rangle = \delta(\mathbf{p} - \mathbf{p}') \delta_{M_S M'_S} \delta_{M_T M'_T}. \quad (2.5)$$

The spin-isospin part and ϕ are completely symmetric, and overall antisymmetry is provided by the color factor $(1/\sqrt{3!})\epsilon_{c_1 c_2 c_3}$.

In parallel with Eq. (1.8), let us calculate the anticommutator of the composite operators C^α and $C^{\alpha\dagger}$ by making use of the basic relation $\{q_\mu, q_\nu^\dagger\} = \delta_{\mu\nu}$:

$$\{C^\alpha, C^{\beta\dagger}\} = \delta^{\alpha\beta} - C^{\alpha\beta} \quad (2.6)$$

with,

$$C^{\alpha\beta} = 3C_{\nu_1 \nu_2 \nu_3}^\alpha C_{\mu_1 \mu_2 \mu_3}^\beta \delta_{\mu_3 \nu_3} (\delta_{\mu_2 \nu_2} q_{\mu_1}^\dagger q_{\nu_1} - \frac{1}{2} q_{\mu_1}^\dagger q_{\mu_2}^\dagger q_{\nu_2} q_{\nu_1}). \quad (2.7)$$

Other anticommutators remain unchanged $\{C^\alpha, C^\beta\} = \{C^{\alpha\dagger}, C^{\beta\dagger}\} = 0$. Again, we remark that this is a well-known situation⁷ in the atomic physics of quantum plasmas—only in the zero-density limit does a composite (e.g., atom or nucleon) obey simple (anti)commutation rules even though its constituents (electrons or quarks) are elementary fermions.

Having dealt with the nucleon state, let us now turn to a model for the $A=3$ nuclear state with spin $= \frac{1}{2}$ and isospin $= \frac{1}{2}$. In analogy with Eq. (1.2) this is

$$|A\rangle = | \boldsymbol{\kappa}, \frac{1}{2} M_S, \frac{1}{2} M_T \rangle \\ = \frac{1}{\sqrt{3!}} \chi^{\alpha_1 \alpha_2 \alpha_3} C^{\alpha_1 \dagger} C^{\alpha_2 \dagger} C^{\alpha_3 \dagger} |0\rangle. \quad (2.8)$$

The nuclear wave function $\chi^{\alpha_1 \alpha_2 \alpha_3}$ is completely antisymmetric in the nuclear coordinates, and the overall nuclear

avoid confusion we will use superscripts for nucleon coordinates and subscripts for quarks. With the convention that a repeated index means a summation over all values of the coordinates (integration over momenta), a single-nucleon state comprised of three quarks is

$$|\alpha\rangle = C^{\alpha\dagger} |0\rangle \\ = \frac{1}{\sqrt{3!}} C_{\mu_1 \mu_2 \mu_3}^\alpha q_{\mu_1}^\dagger q_{\mu_2}^\dagger q_{\mu_3}^\dagger |0\rangle. \quad (2.3)$$

With the standard assumption of SU(6) symmetry [actually SU(4) symmetry since there are no strange quarks here], the totally antisymmetric nucleon wave function $C_{\mu_1 \mu_2 \mu_3}^\alpha$ is expressible in terms of SU(2) Clebsch-Gordan coefficients:

state is completely antisymmetric under the exchange of any two sets of quark coordinates. What is χ ? A very reasonable *Ansatz* is to take this to be the conventional nuclear wave function. In other words, the center-of-mass motion of the three quark clusters is assumed to be given by solution of the Schrödinger equation (or, equivalently, the Faddeev equations) for three nucleons moving under the influence of a phenomenologically determined two-body potential (such as the Reid potential). Conventionally in nuclear physics, of course, the operators are regarded as elementary rather than composite, and quark exchange is ignored by setting $C^{\alpha\beta} \equiv 0$ in Eq. (2.6).

A few additional comments about the form of Eq. (2.8) are in order. First, we note that antisymmetry at the quark level is certainly present in calculations purporting to derive the nucleon-nucleon force from phenomenological QCD-inspired Hamiltonians. Indeed, one could regard Eq. (2.8) as a truncated form of the *Ansatz* used in resonating-group calculations.⁸ It is not apparent that one would get a wave function closer to reality by such a calculation, given the uncertainties in the phenomenological Hamiltonian. Finally, a complete microscopic (i.e., quark) calculation for three-nucleon systems appears to be a virtual impossibility at present.

Even with the simple *Ansatz* Eq. (2.8), a full calculation of exchange effects is very tedious if all three nucleons are allowed to overlap simultaneously. However, if the nuclear density is sufficiently low, or, equivalently, if the nucleon size is sufficiently small, then it should be adequate to discard simultaneous quark exchange among all three nucleons. To be precise, it is assumed that terms such as

$$\chi^{*\alpha_1 \alpha_2 \alpha_3} C_{\rho_1 \mu_2 \mu_3}^{\alpha_1} C_{\nu_1 \sigma_2 \sigma_3}^{\alpha_2} C_{\mu_1 \rho_2 \rho_3}^{\alpha_3} C_{\mu_1 \mu_2 \mu_3}^{\beta_1} C_{\rho_1 \sigma_2 \sigma_3}^{\beta_2} C_{\nu_1 \rho_2 \rho_3}^{\beta_3} \chi^{\beta_1 \beta_2 \beta_3}$$

in the normalization [see Eq. (2.9) below] can be dropped.

Using the antisymmetry of $\chi^{\alpha_1 \alpha_2 \alpha_3}$ and $C_{\mu_1 \mu_2 \mu_3}^\alpha$ under

exchange of their respective superscripts and subscripts, and discarding three-nucleon terms as discussed above, a straightforward calculation yields the nuclear normalization:

$$\langle A | A \rangle = \chi^{*\alpha_1\alpha_2\alpha_3} \chi^{\alpha_1\alpha_2\alpha_3} - \langle A | A \rangle_{\text{exch}} \quad (2.8a)$$

$$\langle A | q_\mu^\dagger q_\mu | A \rangle = 9\chi^{*\alpha_1\alpha_2\alpha_3} (U_{\mu\mu}^{\alpha_1\alpha_2\alpha_3, \beta_1\beta_2\beta_3} - V_{\mu\mu}^{\alpha_1\alpha_2\alpha_3, \beta_1\beta_2\beta_3}) \chi^{\beta_1\beta_2\beta_3}. \quad (2.9)$$

There is no summation on μ . The direct (U) and exchange (V) terms are

$$U_{\mu\mu}^{\alpha_1\alpha_2\alpha_3, \beta_1\beta_2\beta_3} = C_{\mu\sigma_2\sigma_3}^{\alpha_1} C_{\mu\sigma_2\sigma_3}^{\beta_1} \delta^{\alpha_2\beta_2} \delta^{\alpha_3\beta_3}, \quad (2.10a)$$

$$V_{\mu\mu}^{\alpha_1\alpha_2\alpha_3, \beta_1\beta_2\beta_3} = 9C_{\mu\sigma_2\sigma_3}^{\alpha_1} C_{\mu\sigma_2\sigma_3}^{\beta_1} C_{\mu_1\mu_2\mu_3}^{\alpha_2} C_{\mu_2\mu_3\mu_1}^{\beta_2} C_{\rho_1\rho_2\rho_3}^{\alpha_3} C_{\rho_2\rho_3\mu_1}^{\beta_3} + 12\delta^{\alpha_1\beta_1} C_{\mu_1\mu_2\mu}^{\alpha_2} C_{\mu_2\mu\mu_1}^{\beta_2} C_{\rho_1\rho_2\rho_3}^{\alpha_3} C_{\rho_2\rho_3\mu_1}^{\beta_3} + 6\delta^{\alpha_1\beta_1} C_{\mu_1\mu_2\mu_3}^{\alpha_2} C_{\mu_2\mu_3\mu}^{\beta_2} C_{\mu\rho_2\rho_3}^{\alpha_3} C_{\rho_2\rho_3\mu_1}^{\beta_3}. \quad (2.10b)$$

From Eqs. (2.8)–(2.10) it immediately follows that

$$\sum_\mu \langle A | q_\mu^\dagger q_\mu | A \rangle = 9\langle A | A \rangle, \quad (2.11)$$

as required by quark-number conservation. Each of the terms in Eq. (2.10) has a graphical representation, shown in Fig. 1. It is clear that all terms must be retained if charge, baryon number, etc., are to be conserved. An example of omitted (three-nucleon) terms is shown in Fig. 2.

III. EVALUATION OF DIAGRAMS

We now turn to the technical matter of performing the sums implied in Eqs. (2.8)–(2.10), the diagrammatic representations of which are shown in Figs. 1(a)–1(d). The desired quantity is the distribution in momentum of quarks with a specified flavor summed over both quark spin directions, and averaged over nuclear spin and iso-

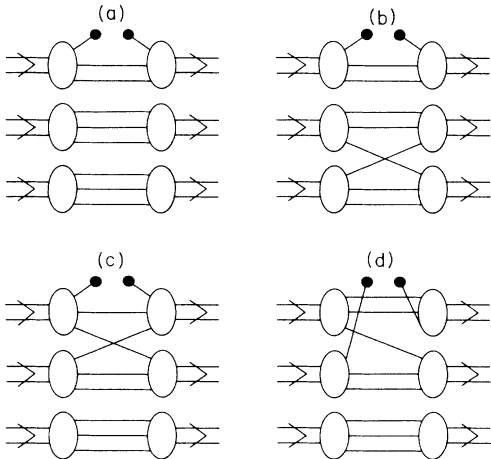

FIG. 1. Graphical representation for the quark one-body operator in a three-nucleon system according to Eq. (1.8) of text. The heavy black dot represents the act of creating or destroying a quark.

$$\langle A | A \rangle_{\text{exch}} = 27\chi^{*\alpha_1\alpha_2\alpha_3} \delta^{\alpha_1\beta_1} C_{\mu_1\mu_2\mu_3}^{\alpha_2} C_{\mu_2\mu_3\mu_1}^{\beta_2} \times C_{\rho_1\rho_2\rho_3}^{\alpha_3} C_{\rho_2\rho_3\mu_1}^{\beta_3} \chi^{\beta_1\beta_2\beta_3}. \quad (2.8b)$$

Next, the expectation of the one quark operator $q_\mu^\dagger q_\mu$ is calculated with respect to the nuclear ground state:

spin. The latter implies that we are dealing with an unpolarized isoscalar (equal mixture of ${}^3\text{He}$ and ${}^3\text{H}$) target. The color sums are trivial: each of the diagrams 1(b), 1(c), 1(d) is multiplied by a factor $\frac{1}{3}$. The momentum and spin-isospin sums will be separately considered in this section.

A. Momentum sums

It is useful to define Jacobi coordinates in both momentum and coordinate space for the $A=3$ system:

$$\begin{aligned} \mathbf{p} &= (\mathbf{p}_2 - \mathbf{p}_3)/2, \quad \mathbf{x} = \mathbf{R}_2 - \mathbf{R}_3, \\ \mathbf{q} &= (\mathbf{p}_2 + \mathbf{p}_3)/3 - 2\mathbf{p}_1/3, \quad \mathbf{y} = (\mathbf{R}_2 + \mathbf{R}_3)/2 - \mathbf{R}_1, \\ \boldsymbol{\kappa} &= \mathbf{p}_1 + \mathbf{p}_2 + \mathbf{p}_3, \quad \mathcal{R} = (\mathbf{R}_1 + \mathbf{R}_2 + \mathbf{R}_3)/3. \end{aligned} \quad (3.1)$$

In the above, \mathbf{p}_i and \mathbf{R}_i are the momentum and position vectors of the nucleon center of mass. The nuclear wave function χ separates into a wave function (plane wave) for the motion of the nuclear center of mass and an internal wave function $\chi(\mathbf{p}, \mathbf{q})$ normalized so that

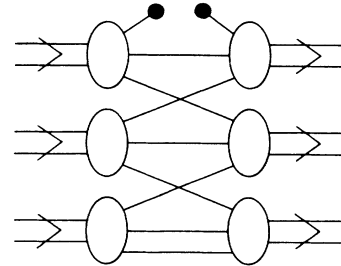

FIG. 2. An example of an omitted three-nucleon correlation term.

$$\int d\mathbf{p} d\mathbf{q} |\chi(\mathbf{p}, \mathbf{q})|^2 = 1. \quad (3.2)$$

$\chi(\mathbf{p}, \mathbf{q})$ is related by a Fourier transform to the coordinate-space wave function $\chi(\mathbf{x}, \mathbf{y})$, which is the result of solving the Faddeev equations in coordinate space.⁹

$$\chi(\mathbf{p}, \mathbf{q}) = \frac{1}{(2\pi)^3} \int d\mathbf{x} d\mathbf{y} e^{-i\mathbf{p}\cdot\mathbf{x}} e^{-i\mathbf{q}\cdot\mathbf{y}} \chi(\mathbf{x}, \mathbf{y}). \quad (3.3)$$

It is easy to see that all of the operators of interest to us commute with \mathbf{q} (and, of course, $\boldsymbol{\kappa}$), so the initial and final nuclear states are characterized by \mathbf{q} and by \mathbf{p}_β and \mathbf{p}_α , respectively.

Although it is easy to write down the multidimensional momentum-space integrals corresponding to Eqs. (2.8)–(2.10), their evaluation for an arbitrary nucleon wave function $\phi(\mathbf{k}_1, \mathbf{k}_2, \mathbf{k}_3; \mathbf{p})$ would be extremely complicated. We shall, instead, resort to a Gaussian approximation. This has the virtue of allowing separation of the nucleon c.m. motion from the motion of its constituents. For a nucleon with momentum \mathbf{p} ,

$$\phi(\mathbf{k}_1, \mathbf{k}_2, \mathbf{k}_3, \mathbf{p}) = \left[\frac{3b^4}{\pi^2} \right]^{3/2} e^{-b^2(\mathbf{k}_1^2 + \mathbf{k}_2^2 + \mathbf{k}_3^2)/2 + b^2\mathbf{p}^2/6}, \quad (3.4)$$

where $\mathbf{p} = \mathbf{k}_1 + \mathbf{k}_2 + \mathbf{k}_3$. The parameter b is essentially the nucleon rms radius. As we shall see in Sec. IV, for $b = 0.8$ – 0.9 fm it is possible to obtain a reasonable description of the nucleon structure function, at least at intermediate x , from a Gaussian distribution of quarks.

Using the Gaussian wave function, all momentum integrals can be expressed rather simply. The operators U and V of Eq. (2.10) may be regarded as acting in the space of the nuclear wave functions $\chi^{\alpha_1\alpha_2\alpha_3}$. Here we evaluate the momentum dependence of these operators, which factors out from their spin-isospin dependence because we assume totally symmetric spatial wave functions both for the nucleon and the nucleus (see below). We denote the operator U by $\hat{A}(\mathbf{k})$ and the three terms in V by $\hat{B}(\mathbf{k})$, $\hat{C}(\mathbf{k})$, and $\hat{D}(\mathbf{k})$, respectively. The operator which appears in the normalization integral, Eq. (2.8b), is denoted by $\hat{E}(\mathbf{k})$. \hat{A} – \hat{D} correspond directly to the diagrams of Fig. 1(a)–1(d):

$$\hat{A}(\mathbf{k}) = \delta(\mathbf{p}_{\alpha_1} - \mathbf{p}_{\beta_1}) \delta(\mathbf{p}_{\alpha_2} - \mathbf{p}_{\beta_2}) \delta(\mathbf{p}_{\alpha_3} - \mathbf{p}_{\beta_3}) \left[\frac{3b^2}{2\pi} \right]^{3/2} \exp\left[-\frac{3}{2}b^2(\mathbf{k} + \mathbf{q}/3)^2\right], \quad (3.5a)$$

$$\hat{B}(\mathbf{k}) = 9\Delta \left[\frac{9b^4}{8\pi^2} \right]^{3/2} \exp\left[-\frac{3}{2}b^2(\mathbf{k} + \mathbf{q}/3)^2\right] \exp(-b^2\mathbf{u}^2/3) \exp(-b^2\mathbf{v}^2/3), \quad (3.5b)$$

$$\hat{C}(\mathbf{k}) = 12\Delta \left[\frac{9b^4}{7\pi^2} \right]^{3/2} \exp\left[-\frac{12}{7}b^2(\mathbf{k} - \mathbf{q}/6 - \mathbf{u}/2)^2\right] \exp(-b^2\mathbf{u}^2/3) \exp(-b^2\mathbf{v}^2/3), \quad (3.5c)$$

$$\hat{D}(\mathbf{k}) = 6\Delta \left[\frac{9b^4}{4\pi^2} \right]^{3/2} \exp\left[-3b^2(\mathbf{k} - \mathbf{q}/6 + \mathbf{v}/2)^2\right] \exp(-b^2\mathbf{u}^2/3) \exp(-b^2\mathbf{v}^2/3), \quad (3.5d)$$

$$E = \Delta \left[\frac{3b^2}{4\pi} \right]^{3/2} \exp(-b^2\mathbf{u}^2/3) \exp(-b^2\mathbf{v}^2/3). \quad (3.5e)$$

The quantities \mathbf{u} , \mathbf{v} , Δ are

$$\mathbf{u} = (\mathbf{p}_\alpha + \mathbf{p}_\beta)/2, \quad (3.6a)$$

$$\mathbf{v} = (\mathbf{p}_\beta - \mathbf{p}_\alpha), \quad (3.6b)$$

$$\Delta = \delta(\mathbf{p}_{\alpha_1} - \mathbf{p}_{\beta_1}) \delta(\mathbf{p}_{\alpha_2} + \mathbf{p}_{\alpha_3} - \mathbf{p}_{\beta_2} - \mathbf{p}_{\beta_3}). \quad (3.6c)$$

It is easy to see that $\frac{1}{9} \int d\mathbf{k} \hat{B}(\mathbf{k}) = \frac{1}{12} \int d\mathbf{k} \hat{C}(\mathbf{k}) = \frac{1}{6} \int d\mathbf{k} \hat{D}(\mathbf{k}) = \hat{E}$.

We now calculate the quark momentum distribution in the nucleus' rest frame:

$$\rho(\mathbf{k}) = \frac{\langle A(\boldsymbol{\kappa}=0) | q^\dagger(\mathbf{k}) q(\mathbf{k}) | A(\boldsymbol{\kappa}=0) \rangle}{\langle A(\boldsymbol{\kappa}=0) | A(\boldsymbol{\kappa}=0) \rangle}. \quad (3.7)$$

This requires taking the expectation of the operators \hat{A} – \hat{E} in the nuclear ground state. Using the connection between the momentum- and coordinate-space wave functions given in Eq. (2.3) and generalizing the notation in an obvious way:

$$A(\mathbf{k}) = \left[\frac{3}{2\pi} \right]^3 \int d\mathbf{x} d\mathbf{y} d\boldsymbol{\delta} e^{-i3\mathbf{k}\cdot\boldsymbol{\delta}} \chi^*(\mathbf{x}, \mathbf{y} + \boldsymbol{\delta}/2) e^{-3\boldsymbol{\delta}^2/2b^2} \chi(\mathbf{x}, \mathbf{y} - \boldsymbol{\delta}/2), \quad (3.8a)$$

$$B(\mathbf{k}) = 9 \left[\frac{3^5}{2^6 \pi^3 b^2} \right]^{3/2} \int d\mathbf{x} d\mathbf{y} d\boldsymbol{\epsilon} d\boldsymbol{\delta} e^{-i3\mathbf{k}\cdot\boldsymbol{\delta}} \chi^*(\mathbf{x} + \boldsymbol{\epsilon}/2, \mathbf{y} + \boldsymbol{\delta}/2) e^{-3\boldsymbol{\delta}^2/2b^2} e^{-3\boldsymbol{\epsilon}^2/4b^2} e^{-3\mathbf{x}^2/4b^2} \\ \times \chi(\mathbf{x} - \boldsymbol{\epsilon}/2, \mathbf{y} - \boldsymbol{\delta}/2), \quad (3.8b)$$

$$C(\mathbf{k}) = 12 \left[\frac{3^5}{2^4 \pi^3 b^2} \right]^{3/2} \int d\mathbf{x} d\mathbf{y} d\epsilon d\delta e^{i6\mathbf{k}\cdot\delta} \chi^*(\mathbf{x} + \epsilon/2, \mathbf{y} + \delta/2) \\ \times e^{-21\delta^2/4b^2} \exp[-3(\epsilon - 3\delta)^2/4b^2] e^{-3x^2/4b^2} \chi(\mathbf{x} - \epsilon/2, \mathbf{y} - \delta/2), \quad (3.8c)$$

$$D(\mathbf{k}) = 6 \left[\frac{3^5}{2^4 \pi^3 b^2} \right]^{3/2} \int d\mathbf{x} d\mathbf{y} d\epsilon d\delta e^{i6\mathbf{k}\cdot\delta} \chi^*(\mathbf{x} + \epsilon/2, \mathbf{y} + \delta/2) \\ \times e^{-3\delta^2/b^2} e^{-3\epsilon^2/4b^2} \exp[-3(\mathbf{x} + 3\delta)^2/4b^2] \chi(\mathbf{x} - \epsilon/2, \mathbf{y} - \delta/2), \quad (3.8d)$$

$$E = \left[\frac{3^3}{2^4 \pi b^2} \right]^{3/2} \int d\mathbf{x} d\mathbf{y} d\epsilon \chi^*(\mathbf{x} + \epsilon/2, \mathbf{y}) e^{-3\epsilon^2/4b^2} e^{-3x^2/4b^2} \chi(\mathbf{x} - \epsilon/2, \mathbf{y}). \quad (3.8e)$$

These integrals are rather difficult (although not impossible) to evaluate as they stand. Fortunately, it will be adequate for our purpose to make the leading-order expansion

$$\chi(\mathbf{x} \pm \epsilon/2, \mathbf{y} \pm \delta/2) = \chi(\mathbf{x}, \mathbf{y}) + \dots, \quad (3.9)$$

which ignores the variation in the nuclear wave function over distances characteristic of the nucleon size (b). This may be viewed equivalently as a low-density or small nucleon radius expansion. In momentum space, it amounts to discarding the nuclear Fermi motion. The approximation must ultimately fail as the nucleon size increases and its validity must be checked. We evaluated E [Eq. (3.8e)] directly using a Monte Carlo integration method and compared it to the approximated expression in Eq. (3.10e) below. The results are displayed in Table I. Evidently the approximation is adequate for $b \leq 1$ fm. The same level of accuracy is expected for the other integrals. Also, the calculation simplifies greatly if only the dominant s channel in the ${}^3\text{He}$ - ${}^3\text{H}$ wave function is kept. This should be valid at the few percent level for two reasons. First, the s channel accounts for about 90% of the probability, the rest being taken up by the mixed symmetry s' channel (1–2%) and d channels (5–9%). The d -channel contribution should be very small because the associated centrifugal barrier tends to reduce nucleon overlap in excess of the nucleon-nucleon short-range repulsion. With the assumption of pure s channel, instead of $\chi = \chi(\mathbf{x}, \mathbf{y})$ we have the much simpler form $\chi = \chi(x, y, \mu)$, where μ is the cosine of the angle between the two Jacobi vectors \mathbf{x} and \mathbf{y} . The simplified integrals are

$$A(\mathbf{k}) = \left[\frac{3b^2}{2\pi} \right]^{3/2} e^{-(3/2)b^2\mathbf{k}^2}, \quad (3.10a)$$

TABLE I. Comparison of the approximated exchange integral I [Eq. (2.12)] with the “exact” (Monte Carlo) value for different values of nucleon rms radius.

| b (fm) | I_{approx} | I_{exact} |
|----------|---------------------|--------------------|
| 0.7 | 0.0355 | 0.0346 |
| 0.8 | 0.0530 | 0.0504 |
| 0.9 | 0.0736 | 0.0686 |
| 1.0 | 0.0966 | 0.0864 |

$$B(\mathbf{k}) = \left[\frac{27b^2}{8\pi} \right]^{3/2} I e^{-(3/2)b^2\mathbf{k}^2}, \quad (3.10b)$$

$$C(\mathbf{k}) = \left[\frac{27b^2}{7\pi} \right]^{3/2} I e^{-(12/7)b^2\mathbf{k}^2}, \quad (3.10c)$$

$$D(\mathbf{k}) = \left[\frac{27b^2}{4\pi} \right]^{3/2} I e^{-3b^2\mathbf{k}^2}, \quad (3.10d)$$

$$E = \left(\frac{3}{2}\right)^3 I, \quad (3.10e)$$

where,

$$I = 8\pi^2 \int_0^\infty x^2 dx \int_0^\infty y^2 dy \\ \times \int_{-1}^{+1} d\mu e^{-3x^2/4b^2} |\chi(x, y, \mu)|^2. \quad (3.11)$$

The strength of the exchange terms B through E is set by the single overlap integral I whose value for various values of b are shown in Table I.

B. Spin-isospin sums

The complete ${}^3\text{H}$ - ${}^3\text{H}$ s -channel wave function is the product of the symmetric spatial wave function χ with a completely antisymmetric wave function ξ , where

$$|\xi\rangle_{\mathcal{M}_J, \mathcal{M}_T} = \frac{1}{\sqrt{2}} |\chi_0 \eta_1 - \chi_1 \eta_0\rangle_{\mathcal{M}_J, \mathcal{M}_T} \quad (3.12)$$

with χ_0 and χ_1 being singlet- and triplet-spin wave functions,

$$|\chi_S\rangle_{\mathcal{M}_J} = C_{M_1 M_2}^{1/2 S} C_{M_3 M}^{1/2 1/2 S} |M_1 M_2 M_3\rangle. \quad (3.13)$$

The isospin wave functions η_0 and η_1 are similarly defined. We shall later perform a sum over azimuthal quantum numbers, so it is best to leave the Clebsch-Gordan (CG) coefficients unevaluated for now.

Consider now the *spin* sum implied on Eq. (2.8b) which involves a sum of products of 12 CG coefficients, of which four come from the two χ 's [see Eq. (3.13)] and eight from the four $C_{\mu\nu\rho}^\alpha$ wave functions. The product of 12 CG coefficients has many pairs of m quantum numbers, and the sum over these pairs can be performed using standard identities to give

$$\begin{aligned}
\langle \chi^\dagger E^{\text{spin}} \chi \rangle &\equiv \chi_S^\dagger E^{\text{spin}(s_1, s_2, s_3, s'_1, s'_2, s'_3)} \chi_{s'} \\
&= 4 \delta_{SS'} \delta_{s_1 s'_1} \delta_{s_2 s'_2} \delta_{s_3 s'_3} \\
&\times \sum_{\mathcal{L}=0,1} (-1)^{S+s_2+s_3+1} (2\mathcal{L}+1) \mathcal{W}(\tfrac{1}{2} \tfrac{1}{2} \tfrac{1}{2} \tfrac{1}{2}; s_2, \mathcal{L}) \mathcal{W}(\tfrac{1}{2} \tfrac{1}{2} \tfrac{1}{2} \tfrac{1}{2}; s_3, \mathcal{L}) \mathcal{W}(\tfrac{1}{2} \tfrac{1}{2} \tfrac{1}{2} \tfrac{1}{2}; S, \mathcal{L}) .
\end{aligned} \tag{3.14}$$

In the above, all S 's take values 0 and 1 only. S and S' are the intermediate *nuclear* spins [see Eq. (3.13)] while s_i and s'_i are the intermediate *nucleon* spins [see Eq. (2.4)]. The result for the isospin sum has a form identical to that in (3.14), and the combined spin-isospin contribution to the normalization is

$$\sum \langle \chi^\dagger E^{\text{spin}} \chi \rangle \langle \eta^\dagger E^{\text{isospin}} \eta \rangle ,$$

where the summation is over all intermediate nucleon spins *and* isospins [note: SU(4) invariance in Eq. (2.4) re-

$$\rho_{\text{dir}}(\mathbf{k}) = \frac{9}{2} \left(\frac{3b^2}{2\pi} \right)^{3/2} e^{-b^2 \mathbf{k}^2 / 2} , \tag{3.15}$$

$$\rho_{\text{exch}}(\mathbf{k}) = \left[\frac{27}{16} e^{-(3/2)b^2 \mathbf{k}^2} + 18 \left(\frac{2}{7} \right)^{3/2} e^{-(12/7)b^2 \mathbf{k}^2} + \frac{9}{\sqrt{8}} e^{-3b^2 \mathbf{k}^2} \right] \left(\frac{3b^2}{2\pi} \right)^{3/2} I . \tag{3.16}$$

The total momentum density is

$$\rho(\mathbf{k}) = \frac{\rho_{\text{dir}}(\mathbf{k}) + \rho_{\text{exch}}(\mathbf{k})}{1 + \frac{9}{8} I} . \tag{3.17}$$

It can be readily verified that

$$\int d\mathbf{k} \rho(\mathbf{k}) = \frac{9}{2} , \tag{3.18}$$

which is a check on the calculation and on the consistency of the approximations we have made.

IV. STRUCTURE FUNCTION

The inclusive scattering of leptons from hadrons is usually described by the hadron structure function $F_2(x, Q^2)$. While the Q^2 dependence can be understood in terms of perturbative QCD, the x dependence at fixed Q^2 lies in the rather poorly understood nonperturbative domain. This x dependence measures the bound-state motion of the hadron's charged constituents. One therefore expects that the quark momentum distribution and hadron structure function will be very closely related. In fact, the structure function measures the distribution of quarks as a function of $k^+ = 1/\sqrt{2}(k^0 + k^3)$ in the target rest frame, which is equivalent to longitudinal momentum in an infinite-momentum frame. Obtaining the structure function from $\rho(\mathbf{k})$ is therefore equivalent to boosting the nucleus to an infinite-momentum frame. To do this properly we require a knowledge of the Hamiltonian which binds the quarks, as well as a relativistic description of the bound state,¹⁰ neither of which we have. Below we suggest a more or less *ad hoc* prescription for k^0 as a function of $|\mathbf{k}|$. We do not believe our results are particular-

quires $s_i = t_i$ and $s'_i = t'_i$]. Finally we note that for the spin-averaged and isospin-averaged system considered here all spin-isospin sums in (2.10b) are identical to those considered above.

C. Combined sum

We are now in a position to put together the combined result for space-spin-isospin color. For the unpolarized isoscalar $A=3$ system considered, the final result for the quark momentum density (either flavor, and summed over quark spin and color only) is

ly sensitive to this prescription for reasons which will be outlined below.¹¹

The structure function $F_2(x)$ is related to the quark probability distribution by

$$F_2^T(x) = x_T \sum_a Q_a^2 f_{a/T}(x_T) , \tag{4.1}$$

where Q_a is the quark charge and $f_{a/T}(x) = dP_{a/T}/dx_T$ is the probability of removing a quark of flavor a from target T with $k^+ = x_T P_T^+$ leaving a physical final state.⁴ x_T is a scaling variable related to Bjorken's x by $x_T = (M/M_T)x$ ($0 < x_T \leq 1$). $f_{a/T}(x_T)$ can be expressed as an integral over the four-momentum of the struck quark:

$$f_{a/T}(x_T) = \int \frac{d^4 k}{(2\pi)^4} \delta \left[\frac{k^+}{p_T^+} - x_T \right] g_{a/T}(k, P) . \tag{4.2}$$

It is clear from its definition⁴ that

$$\int_{-\infty}^{\infty} dx_T f_{a/T}(x_T) = N_{a/T} , \tag{4.3}$$

where $N_{a/T}$ is the number of quarks of flavor a in target T . On general grounds $f_{a/T}(x_T) = 0$ except for $0 < x_T \leq 1$. We will replace the function $g_{a/T}(k, P)$ by $\rho_{a/T}(k)$:

$$f_{a/T}(x_T) \approx \int d^3 k \delta \left[x_T - \frac{k^+}{P^+} \right] \rho(\mathbf{k}) . \tag{4.4}$$

This is not entirely correct because the treatment of the spectators in our construction of $P_{a/T}(k)$ differs from the prescription required for $g_{a/T}(k, P)$ (Ref. 4). As evidence of this, $f_{a/T}(x_T)$ no longer vanishes for $x_T > 1$ or $x_T < 0$. This is a small effect in practice and only important near the end points, $x_T = 0$ or 1, where we do not trust our cal-

calculation for other reasons (see below).

Finally we must specify k^0 as a function of \mathbf{k} . We choose

$$k^0 = [(\mathbf{k}^2 + m^2)]^{1/2} - \epsilon_0, \quad (4.5)$$

where m is the quark mass and ϵ_0 is its binding energy ($\epsilon_0 > 0$). We regard both as parameters to be fit to the nucleon structure function. The rationale for Eq. (4.5) is self-evident: it describes relativistic quarks bound with an energy defect. Other possibilities are $k^0 = (\mathbf{k}^2 + m^2)^{1/2}$ ("on mass shell") or $k^0 = \epsilon_0$ ("on energy shell"). Although these give rise to different maps from $\rho(\mathbf{k})$ to $f(x_T)$, once the parameters of any of these *Ansätze* are adjusted to fit the nucleon structure function, the effect of quark exchange on the ${}^3\text{H}$ - ${}^3\text{He}$ structure function will be quite similar. The *Ansatz* provides for a useful parametrization. For a spherical distribution in momentum space, the angular integrals in Eq. (3.1) can be performed easily to give

$$f_{a/T}(x_T) = 2\pi M_T \int_{k_{\min}}^{\infty} k dk \rho_{a/T}(k), \quad (4.6)$$

$$k_{\min}(x_T) = \frac{(x_T M_T + \epsilon_0)^2 - m^2}{2(x_T M_T + \epsilon_0)}. \quad (4.7)$$

The target structure function $F_2^T(x)$, expressed in terms of $x = Q^2/2M\nu$, where $M = \text{nucleon mass}$, is

$$F_2^T(x) = x \frac{M}{M_T} \sum_{a=u,d} Q_a^2 f_{a/T}(x_T). \quad (4.8)$$

With the relation between quark momentum distribution and structure function now completely defined, we first apply Eqs. (4.6)–(4.8) to the case of an isoscalar (isospin-averaged) nucleon with

$$\rho_{u/N}(\mathbf{k}) = \rho_{d/N}(\mathbf{k}) = \frac{3}{2} \left(\frac{3b^2}{2\pi} \right)^{3/2} e^{-(3/2)b^2\mathbf{k}^2}. \quad (4.9)$$

The corresponding structure function is now fitted to the

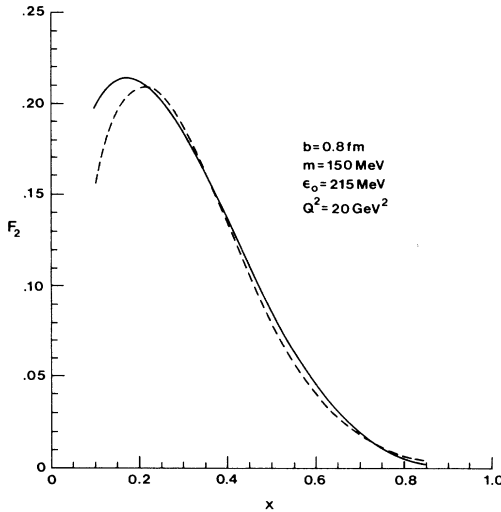

FIG. 3. A comparison of the valence contribution to the isoscalar nucleon structure function (solid curve) against the model result obtained in the text.

valence-quark contribution to $F_2(x)$. For the latter we use the parametrization of Duke and Owens.¹² For $0.75 \lesssim b \lesssim 0.9$ fm one can find values of m and ϵ_0 which give a tolerable fit for $0.25 \lesssim x \lesssim 0.85$. A typical fit is exhibited in Fig. 3. Both for $x \rightarrow 0$ and $x \rightarrow 1$ the model fails because it does not have the correct limiting behaviors. Regge behavior near $x=0$ requires long-range contributions to the quark correlation function in coordinate space,¹³ which are not present in our simple Gaussian model. Near $x=1$, the structure function probes quarks very far from their mass shell in conflict with our *Ansatz*, Eq. (4.5). Fortunately, it is the mid range of x which is the most interesting from the point of view of nuclear physics. We have limited ourselves to isospin-averaged targets because our simple SU(6) wave function cannot account for the difference between the large- x behaviors of the proton and neutron structure functions.

With the parameters m and ϵ_0 now determined for each b value, we now proceed to the final step. The exchange integral I is determined from trinucleon Faddeev wave functions calculated by the Los Alamos group⁹ (Table I), then the momentum density in Eqs. (3.15)–(3.17) is used in Eqs. (4.6)–(4.8). Since each term in ρ is a Gaussian, the integrations are trivial and we may calculate the "EMC ratio" R :

$$R = \frac{F_2^T(x)}{F_2^{T^*}(x)}. \quad (4.10)$$

T is, of course, the $A=3$ target averaged over nuclear spin and isospin and T^* is a hypothetical target with exactly the same quantum numbers but in which the nucleons are sufficiently far removed from each other. The effects of nuclear Fermi motion are excluded from both T and T^* . Here it is purely the exchange of quarks between static nucleons which accounts for the deviation of R from unity.

Figure 4 shows the central result of this paper. The ratio R is plotted over a range of x for two plausible values of nucleon size and for two different nuclear wave func-

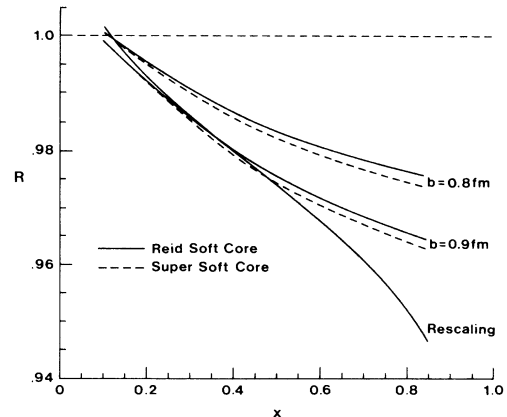

FIG. 4. The EMC ratio R for an $A=3$ isoscalar target, plotted for two different nucleon radii (b) and two different nucleon-nucleon forces. Fermi motion is excluded. For comparison, the rescaling prediction (Ref. 11) is also drawn.

tions. Unfortunately, there is no data on deep-inelastic scattering from ${}^3\text{He}$, much less ${}^3\text{H}$. However, the A dependence of the EMC ratio R has been very successfully predicted by the rescaling model¹⁴ for a wide range of nuclei. One can therefore expect that, within rather small errors, the rescaling prediction plotted in Fig. 4 provides a good approximation to the actual data.

V. DISCUSSION

Our results for the quark-exchange contribution to the EMC ratio R , plotted in Fig. 4, are quite startling. While there is a strong dependence on nucleon size, it appears quite possible that much of the EMC effect may be attributed to quark exchange between nucleons. There is no question that if nucleons are extended objects comprised of quarks then such exchanges must occur and give nonadditive contributions to the nuclear structure functions. However, prior to drawing *quantitative* conclusions it is useful to recapitulate the various assumptions and approximations used in this paper.

(1) We employ an *ad hoc* prescription to go from the rest-frame momentum distribution $\rho(\mathbf{k})$ to the structure function. While one can successfully parametrize the experimentally determined structure function (see Fig. 3) for intermediate x values, this by itself says nothing about the validity of our *Ansatz*. On the other hand, we are only interested in the ratio of the nuclear structure function to that of the free nucleons. If one fits the nucleon structure function well, one can expect to estimate the small corrections due to quark exchange reliably. *Even if one fails to fit the nucleon structure function, our results for the shape of $R(x)$ remain much the same.* This is borne out by the insensitivity of R to the parameters m and ϵ_0 . As remarked earlier, the overall magnitude of $R(x)$ is strongly dependent on the nucleon's spatial size, but this is precisely what one would have expected.

(2) Assumption of pure nucleon basis. When two nucleons approach each other, Δ and hidden-color degrees of freedom can be excited. We have ignored such excitations, expecting that the N - N channel is dominant. A more elaborate calculation, such as with resonating

groups,⁸ could check this assumption.

(3) Limitation of two nucleon correlations. Referring to Figs. 1(a)–1(d), it can be seen that quarks are exchanged only between pairs of nucleons. There are also terms in which simultaneous exchanges occur among three correlated nucleons (see Fig. 2). But give the smallness of the two-body exchange term, it should be an excellent approximation to drop such terms.

(4) Neglect of Fermi motion in the exchange terms. In Eqs. (3.8), the complexity of evaluating the multidimensional integrals made it convenient to expand in the parameter b/λ , where λ is the scale of the nuclear wave function. By means of a Monte Carlo integration, it was verified that this should be reasonably accurate for $b \lesssim 1$ fm (see Table I).

(5) Limitation to dominant s channels in the trinucleon wave function. Both smallness of the remaining channel (probability $\lesssim 10\%$) and the centrifugal repulsion associated with D states (which reduces nucleon overlap) should make this a good approximation.

(6) Finally, many other potentially important coherent effects have been ignored in our calculation. Among these are final-state interaction, vertex corrections, and interference between the debris of the struck nucleon and spectators in the nucleus.

Given the importance of exchange effects in the relatively dilute $A=3$ nuclei discussed here, it is certain that for heavier nuclei these will be even more pronounced. Quite possibly a good fraction of the EMC effect may be explainable by the quark-exchange mechanism.

ACKNOWLEDGMENTS

One of us (P.H.) would like to thank Professor John Negele for an invitation to visit MIT where this work was initiated, and the Physics Department of Carnegie-Mellon University for hospitality during 1985–1986. The work of P.H. was supported in part by NSF Grant No. PHY84-06555. The work of R.L.J. was supported in part by Boston University and in part through funds provided by the U.S. Department of Energy under Contract No. DE-AC02-76ER3069.

*Permanent address: Physics Department, Quaid-e-Azam University, Islamabad, Pakistan.

¹J. J. Aubert *et al.*, Phys. Lett. **123B**, 275 (1983).

²C. H. Llewellyn Smith, Phys. Lett. **128B**, 109 (1983); M. Ericson and A. W. Thomas, *ibid.* **128B**, 112 (1983).

³E. L. Berger and F. Coester, Phys. Rev. D **32**, 1071 (1985).

⁴R. L. Jaffe, MIT Report No. CTP-1261 (unpublished).

⁵R. L. Jaffe, in *Workshop on Nuclear Chromodynamics*, edited by S. Brodsky and E. Moniz (World Scientific, Singapore, 1986).

⁶The possibility of quark exchange between nucleons has been noted previously by L. I. Frankfurt and M. I. Strickman (private communication). Also, M. Betz, G. Krein, and Th. A. J. Maris, Nucl. Phys. **A437**, 509 (1985) attempted a calculation of quark-exchange effects in a nuclear Fermi gas. However, both their evaluation of the quark momentum distribution and their method of relating it to the structure func-

tion are flawed and their results are not reliable.

⁷For a discussion of composite systems in atomic physics, see M. D. Girardeau, J. Math. Phys. **16**, 1901 (1975).

⁸A. Faessler, Prog. Part. Nucl. Phys. **11**, 171 (1984).

⁹J. L. Friar, E. L. Tomusiak, B. F. Gibson, and G. L. Payne, Phys. Rev. C **24**, 665 (1981).

¹⁰For an example of such a calculation, see R. L. Jaffe, Ann. Phys. (N.Y.) **132**, 32 (1981).

¹¹A useful discussion of structure functions is given by A. De Rújula and Francois Martin, Phys. Rev. D **22**, 1787 (1980).

¹²D. W. Duke and J. F. Owens, Phys. Rev. D **30**, 49 (1984).

¹³See, for a discussion, C. H. Llewellyn Smith, in *Particles and Nuclei*, proceedings of the Tenth International Conference, Heidelberg, 1984, edited by B. Povh and G. zu Pulitz [Nucl. Phys. **A434**, 35c (1985)].

¹⁴F. E. Close, R. L. Jaffe, R. G. Roberts, and G. G. Ross, Phys. Rev. D **31**, 1004 (1985).