

Experimental Test of Coulomb's Law*

D. F. BARTLETT, P. E. GOLDHAGEN, AND E. A. PHILLIPS†

Joseph Henry Laboratories of Physics, Princeton University, Princeton, New Jersey 08540

(Received 17 April 1970)

One of the classic "null experiments" tests the exactness of the electrostatic inverse-square law. The outer shell of a spherical capacitor is raised to a potential V with respect to a distant ground, and the potential difference ΔV induced between the inner and outer shells is measured. If this induced potential difference is not zero, Coulomb's law is violated. For example, if we assume that the force between charges varies as r^{-2+q} , then $\Delta V/V$ is approximately a tenth of q . In our experiment five concentric spheres are used. A potential difference of 40 kV at 2500 Hz is impressed between the outer two spheres. A lock-in detector with a sensitivity of about 0.2 nV measures the potential difference between the inner two spheres. We find $|q| \leq 1.3 \times 10^{-13}$. We also find comparable limits on the detected signal when the operating frequency is 250 Hz, and when the detector is synchronized with the charging current rather than with the charge itself.

HISTORY

FEW investigations in physics have enjoyed as sustained an interest as has the test of Coulomb's law. Using a torsion balance, Coulomb demonstrated directly that two like charges repel each other with a force that varies inversely as the square of the distance between them.¹ Subsequent precise tests of this law, however, have been patterned on the null experiment of Cavendish, who noted that there should be no electric forces inside a hollow charge-free cavity in a conductor if the force between charges obeys the inverse square law.² He showed that when the outer of two concentric conducting spherical shells was charged, less than 1/60 of the charge moved to the inner shell along a thin wire connecting the two spheres. In an improved version of this experiment, Maxwell found that the exponent of r in Coulomb's law could differ from two by no more than 1/21 600.³

Both Cavendish's and Maxwell's experiments required that a connection be made from the inner sphere to an electrometer after the outer sphere had been discharged. The accuracy of the measurement of the potential of the inner sphere was thus limited by varying contact potentials. This problem was overcome by Plimpton and Lawton,⁴ who in 1936 charged an outer sphere with a slowly varying alternating current and detected the potential difference between the inner and outer spheres with a frequency resonant electrometer permanently mounted inside them. With this technique they succeeded in reducing Maxwell's limit to 2×10^{-9} .

The recent development of phase-sensitive amplifiers

("lock-in amplifiers") has encouraged several new attempts to test Coulomb's law. One of these experiments has already been reported,⁵ as have preliminary results of this experiment.⁶ Results from an experiment using megacycle charging frequencies are expected shortly.⁷

THEORY

Suppose that the force between two unit charges is an arbitrary function $F(r)$ of the distance between them. Let the associated electrostatic potential be

$$U(r) = \int_r^\infty F(s) ds. \quad (1)$$

Then if a unit charge is spread uniformly over a sphere of radius a , the potential at a distance r from the center of the sphere is readily determined to be⁸

$$V(r) = [f(r+a) - f(|r-a|)]/2ar, \quad (2)$$

where

$$f(r) = \int_0^r sU(s) ds.$$

In particular, the potential induced on a sphere of radius r by a charge placed uniformly on a concentric sphere of radius $a > r$ is given by

$$\frac{V(r) - V(a)}{V(a)} = \frac{a}{r} \left[\frac{f(a+r) - f(a-r)}{f(2a)} \right] - 1. \quad (3)$$

Following Maxwell, we may imagine that the exponent in Coulomb's law is not -2 but $(-2+q)$, where $|q| \ll 1$. In that case, to first order in q , $U(r) = r^{-1+q}$, $f(r) = r(1+q \ln r)$, and Eq. (3) gives

$$[V(r) - V(a)]/V(a) = qM(a,r),$$

⁵ Gary Don Cochran, Ph.D. thesis, University of Michigan, 1967 (unpublished); G. D. Cochran and P. A. Franken, *Bull. Am. Phys. Soc.* **13**, 1379 (1968).

⁶ D. F. Bartlett and E. A. Phillips, *Bull. Am. Phys. Soc.* **14**, 17 (1969).

⁷ J. Faller (private communication). *Note added in proof.* A preliminary result from this experiment gives a limit $q \leq 1.1 \times 10^{-14}$. E. R. Williams, J. E. Faller, and H. A. Hill, *Bull. Am. Phys. Soc.* **15**, 586 (1970).

⁸ See Ref. 2, p. 84.

* Research supported by the Research Corporation and by the U. S. Atomic Energy Commission under Contract No. AT(30-1)-2137.

† Now at Lawrence Radiation Laboratory, Berkeley, Calif. 94720.

¹ A. Coulomb, *Memoires de l'Académie Royale des Sciences*, Vol. for 1785, p. 569.

² Though this experiment antedated Coulomb's experiment by 12 years, it was not published until 1873. See J. C. Maxwell, *A Treatise on Electricity and Magnetism*, 3rd ed. (Oxford U. P., Oxford, England, 1892), Vol. I, p. 80.

³ See Ref. 2, p. 83.

⁴ S. J. Plimpton and W. E. Lawton, *Phys. Rev.* **50**, 1066 (1936).

where

$$M(a,r) = \frac{1}{2} \left[-\ln \left(\frac{a+r}{a-r} \right) - \ln \left(\frac{4a^2}{a^2-r^2} \right) \right]. \quad (4)$$

Note that $M(a,r)$ is of order unity, so that q is essentially the quotient of the measured potential difference $V(r) - V(a)$ and the applied voltage $V(a)$.

Alternatively, following deBroglie,⁹ we may imagine Maxwell's equations to be generalized in the simplest fashionable way. If the photon has a small nonzero rest mass, two charges will repel each other by a "Yukawa" force derived from the potential

$$U(r) = e^{-kr}/r, \quad (5)$$

where $k = m_\gamma c/\hbar$ is the inverse Compton wavelength of the photon. In the limit $ka \ll 1$, $U(r) = 1/r - k + \frac{1}{2}k^2r$ and Eq. (3) gives

$$[V(r) - V(a)]/V(a) = -\frac{1}{6}k^2(a^2 - r^2). \quad (6)$$

Note that the quadratic dependence of the potential difference $V(r) - V(a)$ on k makes this method rather insensitive to small values of k . Other methods for determining k use terrestrial measurements at either large distances or long times, where the percentage effect would be much higher. These include (a) satellite verification that the magnetic field of the earth falls off as $1/r^3$ out to distances at which the solar wind is appreciable,¹⁰ (b) observation of the propagation of hydromagnetic waves through the magnetosphere,¹¹ and (c) a search for a component of the earth's magnetic field which is independent of latitude and longitude.¹² All three methods give roughly the same limit, $k \lesssim 10^{-10} \text{ cm}^{-1}$.

In this paper we wish to apply Maxwell's derivation [Eqs. (2) and (3)] to a case where a conducting sphere is raised to a potential V and the induced potential difference between this sphere and a smaller concentric one is measured. Irregularities in the shapes of these conductors apparently are not important since there should be no electric field inside a cavity of any shape unless Coulomb's law is violated. Indeed, Cochran and Franken⁵ used conducting rectangular boxes to set the limit $|q| \lesssim 10^{-11}$. Recently, however, Shaw¹³ has raised an intriguing point concerning the assumption that charge will distribute itself uniformly over the surface of an isolated conducting sphere. In conventional electrostatics, this uniform charge distribution follows from the symmetry of the problem and the uniqueness of the solution. But the uniqueness theorem has only been proved for Coulomb and Yukawa potentials; if neither of these is valid, charge may be

⁹ L. deBroglie, *Une Nouvelle Théorie de la Lumière* (Hermann, Paris, 1940), p. 40.

¹⁰ M. A. Ginzburg, *Astron. Zh.* **40**, 703 (1963) [*Soviet Astron. AJ* **7**, 536 (1964)].

¹¹ V. L. Patel, *Phys. Letters* **14**, 105 (1965).

¹² A. S. Goldhaber and M. M. Nieto, *Phys. Rev. Letters* **21**, 567 (1968).

¹³ Ronald Shaw, *Am. J. Phys.* **33**, 300 (1965).

distributed on an isolated spherical conductor in any number of nonuniform ways.¹⁴ One might expect that the induced potential on an inner sphere would depend on the particular charge distribution, and although by symmetry the average of all possible distributions is uniform,¹³ it is probable that irregularities in the spherical surface would bias the spectrum of observed distributions. However, any violation of Coulomb's law is very small. If the resulting departure of the charge distribution from uniformity is similarly small, it gives only a second-order correction to Maxwell's estimate of $V(r) - V(a)$.

DESIGN OF EXPERIMENT

In the measurement of Plimpton and Lawton,⁴ a 3-kV 2-Hz sinusoidal signal was applied between a distant ground and the outer shell of a spherical capacitor. A resonant amplifier connected between the shells of the capacitor failed to measure any potential difference although a voltage of 1 μ V would have been easily detectable. They concluded that $|q| \leq 2 \times 10^{-9}$.

Our experiment is basically an elaboration of theirs. Instead of two concentric spheres, we have used five. The voltage was applied between the two outermost, and the induced signal between the two innermost was measured. The middle sphere served as a shield. Their dimensions were as follows:

| Sphere number | Material | Mean diameter (m) | Thickness (cm) |
|---------------|----------|-------------------|----------------|
| 4 | aluminum | 2.96 | 0.06 |
| 3 | steel | 1.10 | 5 |
| S | copper | 1.00 | 0.19 |
| 2 | aluminum | 0.91 | 0.17 |
| 1 | aluminum | 0.76 | 0.14 |

The largest sphere, No. 4, was formed by bolting together two hemispherical aluminum silo covers. It served as a local ground for the apparatus. The remaining four spheres were all fabricated from mating hemispheres which could be separated. The high voltage was applied to the heavy steel sphere, No. 3. A lock-in amplifier¹⁵ capable of measuring signals less than 1 nV was connected between the two smallest spheres. The copper shield was not inserted until the last part of the experiment.

The rationale for this design was simple. Johnson noise in the input to the amplifier is bypassed by the capacitance between spheres No. 1 and No. 2, giving a noise voltage which varies inversely as the frequency. It was necessary to charge the steel sphere at a fre-

¹⁴ It also may not. Shaw notes that the usual proof of the uniqueness theorem relies on the fact that the potential satisfies a second-order field equation. We may speculate that any formulation of electrostatics which recognizes the existence of electromagnetic radiation will satisfy a wave equation that reduces in the static case to such a field equation, allowing a proof of the uniqueness theorem.

¹⁵ Princeton Applied Research Co. Model HR-8, modified by increasing the input resistors from 10 to 100 M Ω .

quency of about 1 kHz to reach a noise level of 0.1 nV. However, at such a frequency the sphere developed a sizable potential gradient due to the interaction of the charging current (which is proportional to frequency) with its resistance and inductance. The voltage difference between the top (where the current was applied) and the bottom of the steel sphere was estimated to be 1 mV. Thus additional shielding was required. This was provided by (a) using a sphere 5 cm thick to carry the charging currents, (b) measuring the potential difference between two isolated aluminum spheres, and (c) interposing a copper shield for further protection.

The input to the lock-in amplifier was connected between radially separated points on the two aluminum spheres. Since the apparatus was surrounded by alternating magnetic fields, small induced currents might be expected to flow between these two points. If 10^{-15} of the current required to charge the steel sphere were to enter the amplifier, a 1 nV signal would be recorded.¹⁶ This signal could easily be taken for a violation of Coulomb's law. To guard against this possibility, we measured the potential difference between the aluminum spheres at various latitudes and longitudes. A genuine violation of Coulomb's law would give a signal independent of this "pickoff" point. An induced signal will average to zero as the pickoff point is varied since it is proportional to the radial electric field at the pickoff point, and the surface integral of the electric field vanishes by Gauss's law.

A schematic diagram of the apparatus is shown in Fig. 1. The electronics was battery operated and located inside the smallest sphere. The output of the lock-in amplifier was transcribed by a small chart recorder.¹⁷ To operate properly a lock-in amplifier requires a reference signal which is synchronized with the signal to be measured. This signal was provided by a sinusoidally modulated light beam controlled by the same oscillator that controlled the high voltage. The transmitter was a neon bulb and the receiver was a photoconductive cell. To obtain the high voltage, a signal from the oscillator was amplified by two 200-W audio amplifiers and then fed to the primary of a specially built air-core transformer.¹⁸ The secondary of the transformer supplied current to the steel sphere through a high-pressure gas-filled coaxial cable. Maximum voltage was achieved by choosing the frequency of operation so that the inductance of the secondary resonated with the combined capacitances of the cable and the steel sphere. Two different transformer secondaries permitted operation at 250 and 2500 Hz. The Q

¹⁶ Indeed, a 10-nV signal of this kind was observed when the lock-in amplifier was connected between the steel sphere No. 3 and sphere No. 2.

¹⁷ Data at 250 Hz were monitored by transmitting the output of the lock-in amplifier out of the spheres as a modulation of the frequency of light pulses similar to the reference signal transmission. This readout system was abandoned during operation at 2500 Hz because it generated spurious input signals to the lock-in.

¹⁸ Manufactured by Field Electronics Inc., Chatham, N. J.

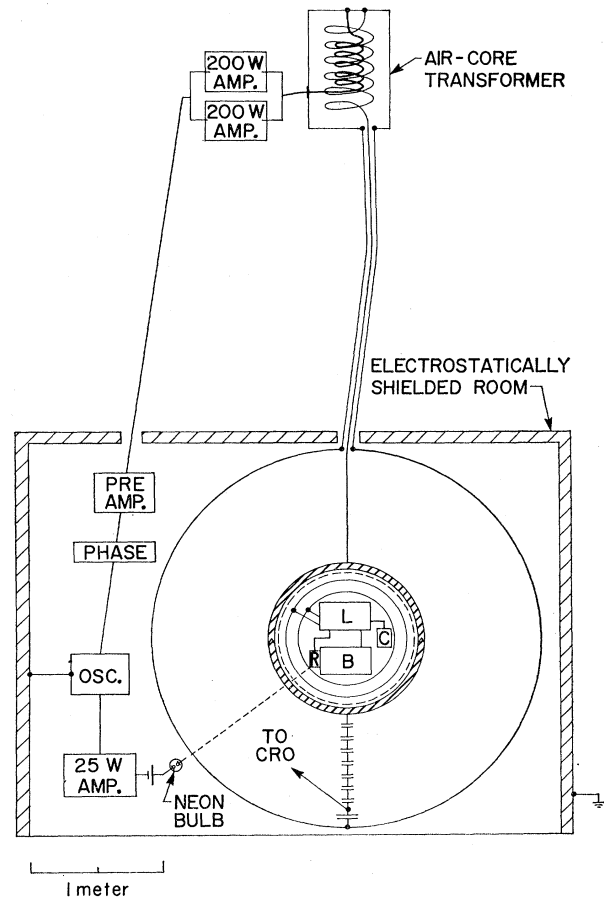

FIG. 1. Schematic of the apparatus (as used for 2500-Hz measurements). L is the lock-in amplifier; C is the chart recorder; R is the light receiver; and B is the five 12-V storage batteries.

of the charging system at each frequency was about ten. The transformer was mounted outside the electrostatically shielded room which contained the rest of the equipment in order to reduce the alternating magnetic fields at the spheres.

CALIBRATION

There is a clear need for a calibrating measurement in an experiment where the recording apparatus is concealed in a "black box" and where the expected answer is zero. The simplest way to calibrate the detector is to let a known fraction of the impressed high voltage appear between spheres No. 1 and No. 2. Surprisingly, drilling a hole through spheres No. 3 and No. 2 does not work. Since the steel sphere is so thick, even a hole 1 cm in diameter does not let in a detectable fraction of the high voltage to the space between No. 3 and No. 2, and the signal which gets through the hole in No. 2 is smaller yet. This fact was discovered when we drilled a hole for the light beam carrying the reference signal; however, all holes in the steel sphere were plugged or covered with metal screening during all data runs.

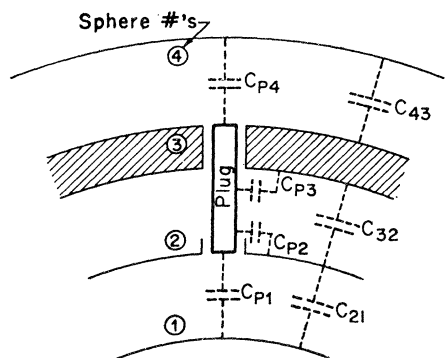

FIG. 2. Calibration plug. Schematic and equivalent circuit diagram. $(V_2 - V_1)/(V_3 - V_4) \approx C_{P1}C_{P4}/C_{21}(C_{P2} + C_{P3})$.

A proper capacitive voltage divider was built by drilling a small hole through No. 3 and No. 2 and then filling the hole with an insulated metal plug. The equivalent circuit is shown in Fig. 2. In this way about 10^{-12} of the high voltage was made to appear between the aluminum spheres. The calculated and measured calibrating signals agreed to within 30%.

DATA COLLECTION

Before closing the spheres for a run, the phase control of the lock-in amplifier was set so that it would give maximum output for a signal occurring in phase with the oscillator. After the spheres were closed, the phase of the high voltage could be adjusted to lead the oscillator by 0° , 90° , 180° , or 270° .

Typically, data were taken with the spheres closed for four hours. For the first ten minutes the impressed high voltage was adjusted to have the same phase as the oscillator. A null run for comparison could have been made by turning the high voltage off for the next ten minutes. However, the sensitivity of the experiment can be doubled if during the second interval the high voltage is applied 180° out of phase with the oscillator.⁵ Half the difference between the signals detected in the first and second intervals is then the desired signal

TABLE I. 250-Hz measurements. (High voltage = 70 000 V rms.)

| Location of low-voltage pickoff | | Low-voltage signal $(V_2 - V_1)$ | |
|---------------------------------|-------------------|----------------------------------|-----------------------|
| Azimuthal angle (deg) | Polar angle (deg) | "Q" ^a (nV) | "I" ^b (nV) |
| ... | 0 | +0.1 | -0.5 |
| 0 | 60 | +1.5 | +1.1 |
| 0 | 60 | +0.4 | -0.2 |
| 120 | 60 | +0.4 | -1.4 |
| 240 | 60 | +0.2 | -0.9 |
| 0 | 97 | -0.3 | +1.1 |
| 0 | 97 | +2.1 | -0.2 |
| 0 | 110 | +0.2 | +0.1 |
| 0 | 170 | +0.5 | +0.8 |
| Av | | +0.6 | 0.0 |

^a "Q" signal is positive when $V_2 - V_1$ is in phase with $V_3 - V_4$.

^b "I" signal is positive when $V_2 - V_1$ leads $V_3 - V_4$ by 90° .

$V_2 - V_1$ occurring in phase with the charge on the steel sphere (the "Q" signal). The results from eight such pairs of 10-min intervals were averaged. Similarly, a measurement was made of the signal $V_2 - V_1$ occurring in phase with the current charging the steel sphere (the "I" signal). The spheres were then opened and the recorder chart extracted. The pickoff point was changed to a new position and another run started. Because of the symmetry of the apparatus about a vertical axis, the polar angle of the pickoff point was generally varied and the azimuthal angle only occasionally.

The first set of data was taken with a high voltage of 70 kV at 250 Hz. The results are shown in Table I. From these data, we concluded that for both the Q signal and the I signal

$$\left| \frac{V_2 - V_1}{V_3 - V_4} \right| \leq \frac{1.2 \text{ nV}}{70 \text{ kV}} = 1.7 \times 10^{-14}. \quad (7)$$

A detailed examination of the data used to prepare Table I suggested a difficulty, however. For any particular position of the pickoff point, the fluctuation of the Q signal due to thermal noise in the 100-M Ω input resistance of the lock-in amplifier was calculated to be 0.3 nV. This value agreed well with the observed fluctuations of the eight separate pairs of 10-min intervals in one run. Yet two runs at the same pickoff point gave Q signals differing by more than 2 nV. Clearly there was a lack of reproducibility in assembling the apparatus, probably in the contact between the hemispheres which were opened after every run (see Fig. 3).^{18a}

At this point we changed the operating frequency to 2500 Hz hoping that the problem would either be alleviated or aggravated to the extent that its true cause could be found. The latter expectation proved to be correct. At the new frequency, the detected signal was a clear function of the degree of contact between the top and bottom steel hemispheres. Despite the weight of the top sphere and the large area available for contact in the V groove (Fig. 3), they were usually touching at only 8 points. To improve this contact, we lapped the top and bottom hemispheres together and then plated the mating surfaces with 0.001 in. of an indium-tin alloy topped with a flash plating of gold. Finally the two hemispheres were tightly bolted together. This procedure achieved contact between them in a nearly continuous band about 0.5 cm wide near the top of the V groove. As an added precaution, we installed the insulated copper sphere mentioned earlier, which shielded the inner spheres from residual irregular currents near the equator of the steel sphere.

^{18a} Note added in proof. One source of such a spurious signal could be stress induced variations in the contact potential between the top and bottom aluminum hemispheres [see P. P. Craig, Phys. Rev. Letters 22, 700 (1969)]. However the level of audio hum in one experiment was about 40 db. From this we estimate that the synchronous variation in contact potential is about 10^{-12} V.

The second set of data was taken at 2500 Hz. At this frequency the output of the transformer was limited to 40 kV by eddy-current losses in its housing. The results are shown in Table II. We believe that a signal of 0.3 nV would easily have been detected in these data, and therefore conclude that

$$\left| \frac{V_2 - V_1}{V_3 - V_4} \right| \leq \frac{0.3 \text{ nV}}{40 \text{ kV}} = 0.8 \times 10^{-14} \quad (8)$$

for both the Q and the I signal. At this frequency the statistical error of about 0.13 nV for an entry in Table II is roughly compatible with the reproducibility for two different boltings at the same pickoff. The Johnson noise in the input resistor is only 0.03 nV, so other sources of noise are affecting the detector at this low signal level.

RESULTS

We wish to calculate the extent to which the exponent in Coulomb's law can deviate from -2 . Generalizing Eq. (4) to the case where a charge $-Q$ is placed on the ground sphere (No. 4) in addition to the charge $+Q$ placed on the steel sphere (No. 3), we have¹⁹

$$\begin{aligned} \frac{V_2 - V_1}{V_3 - V_4} &= q \frac{r_4}{r_4 - r_3} [M(r_3, r_2) - M(r_3, r_1)] \\ &\quad - q \frac{r_3}{r_4 - r_3} [M(r_4, r_2) - M(r_4, r_1)] \\ &= -0.077q. \end{aligned} \quad (9)$$

Since the capacitance of the coaxial cable connecting the aluminum spheres to the lock-in amplifier was 25%

TABLE II. 2500-Hz measurements. (High voltage = 40 000 V rms.)

| Location of low-voltage pickoff | | Low-voltage signal ($V_2 - V_1$) | |
|---------------------------------|-------------------|------------------------------------|----------|
| Azimuthal angle (deg) | Polar angle (deg) | Q (nV) | I (nV) |
| ... | 0 | -0.15 | +0.24 |
| ... | 0 | +0.44 | ... |
| 20 | 60 | -0.19 | +0.29 |
| 240 | 60 | +0.36 | +0.01 |
| 0 | 97 | -0.12 | +0.42 |
| 0 | 135 | +0.16 | -0.31 |
| 0 | 170 | +0.31 | +0.10 |
| 0 | 170 | +0.09 | +0.06 |
| Av | | +0.12 | +0.12 |

¹⁹Note that neither the thickness of sphere No. 3 nor the presence of conducting surfaces inside sphere No. 1 alters the validity of this computation. In a thick conductor a fraction of the charge of the order of q migrates toward the inner surface to maintain the conductor as an equipotential. This migration has only a second-order effect on $V_2 - V_1$.

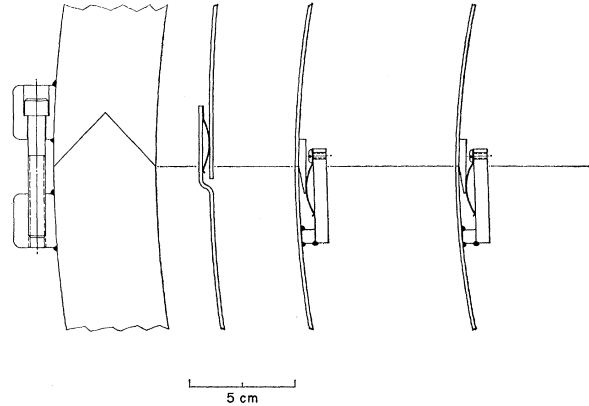

FIG. 3. Detail of contact between hemispheres showing phosphor-bronze fingers used on the three inner spheres, and one of six bolts added to ensure good electrical contact across V groove in steel sphere.

that of the spheres themselves, only 0.8 of the voltage $V_2 - V_1$ was actually recorded. Thus we find from Eq. (8)

$$|q| \leq \frac{0.8 \times 10^{-14}}{(0.077)(0.8)} = 1.3 \times 10^{-13}.$$

Alternatively, we may generalize Eq. (6) to find a limit for the inverse Compton wavelength of the photon:

$$(V_2 - V_1 / V_3 - V_4) = \frac{1}{6} k^2 (r_2^2 - r_1^2); \quad k \leq 1 \times 10^{-8} \text{ cm}^{-1}.$$

This limit to the rest mass of the photon is a factor of 100 poorer than that found by the terrestrial measurements cited earlier. It must be noted, however, that these are measurements of much less inherent precision and are more sensitive only to this particular form of deviation from Coulomb's law.

In closing, we assume the force between charges to vary as r^{-2+a} and summarize the upper limits which have been found for $|q|$:

| | |
|----------------------------|-----------------------|
| Coulomb (1785) | 4×10^{-2} |
| Cavendish (1773) | 2×10^{-2} |
| Maxwell (1873) | 4.9×10^{-5} |
| Plimpton and Lawton (1936) | 2.0×10^{-9} |
| Cochran and Franken (1968) | 9.2×10^{-12} |
| This work | 1.3×10^{-13} |

ACKNOWLEDGMENTS

We gratefully acknowledge the advice and encouragement given us by Jack Riedel and Dr. E. Ralph Kotter and Dr. Gary Cochran. The experiment benefited markedly from technical assistance given by Howard Edwards, Walter Davidson, Fred Schwartz, and Walter Bell.