

## Study of the longitudinal kink modes of the string

W. A. Bardeen\*

*Fermi National Accelerator Laboratory, Batavia, Illinois 60510*

Itzhak Bars†

*Department of Physics, Yale University, New Haven, Connecticut 06520*

Andrew J. Hanson\*

*Stanford Linear Accelerator Center, Stanford University, Stanford, California 94305*

R. D. Peccei‡

*Institute of Theoretical Physics, Department of Physics, Stanford University, Stanford, California 94305*

(Received 18 December 1975)

We examine the massless limit of a model for the massive relativistic Nambu string. The system possesses longitudinal kink modes excluded from the standard lightlike gauge treatment. We demonstrate the equivalence of these modes to those proposed by Patrascioiu. The classical nonlinear field theory of the two-dimensional string is shown to be a completely integrable Hamiltonian system. The Hamiltonian is expressed in terms of normal-mode action variables alone; the mass-squared spectrum is linear in the Bohr-Sommerfeld approximation. The difficulties of canonical quantization are exposed using a particular timelike gauge which admits commuting center-of-mass coordinates.

### INTRODUCTION

The massless relativistic string model derived from the Nambu action functional<sup>1</sup> is widely believed to be connected in an essential way with the dual models for strong interactions. It is therefore puzzling that despite the desirable features of the dual models, the free-string quantization procedure of Goddard, Goldstone, Rebbi, and Thorn<sup>2</sup> (GGRT) and the interacting string quantization of Mandelstam<sup>3</sup> succeed only in 26-dimensional spacetime. Patrascioiu<sup>4</sup> has pointed out that this phenomenon may occur due to the omission of longitudinal modes of oscillation which appear when the massless string action principle is suitably generalized. Patrascioiu's modes belong to a class of solutions with discontinuous derivatives which appear to be excluded from the GGRT solutions due to a singularity in their choice of coordinates.

Our purpose here is to reexamine the string with particular attention to the longitudinal modes in two spacetime dimensions. We argue that a physically sound procedure for constructing the Hamiltonian is to define the massless relativistic string as the smooth massless limit of a *massive* relativistic string.<sup>5</sup> Then the longitudinal modes remain in the theory as subtle minima of the action principle: In two dimensions these motions appear as massless limits of the solutions to the massive Euler equations, but cannot be derived from the standard Euler equations if the masses are set equal to zero before the variation. We

note that the string is an essentially nonlinear system if the constraint equations are taken into account; the longitudinal modes of the string behave precisely like kink solutions of a nonlinear field theory, which enormously complicates any attempt at canonical quantization of the independent modes.

Our eventual aim is to write down the full quantum Hamiltonian and Poincaré group generators for the longitudinal plus transverse string oscillations in  $D$  dimensions, and then investigate positivity and Lorentz covariance for  $D=4$ . This program remains for the moment incomplete, so this work will concentrate on limited sectors of the full theory.

We begin by deriving the Hamiltonian dynamics of the massive relativistic string system. This yields a system of particles interacting via a relativistic potential which becomes linear in two dimensions. Then we take the massless limit of the massive theory, obtaining longitudinal modes of oscillation. We thus find a more physical understanding of the motions proposed by Patrascioiu, who used different methods. One section is devoted to showing the equivalence of our simplest mode to Patrascioiu's orthonormal-gauge solution. Working mostly in two spacetime dimensions, where no transverse solutions exist, we approximate the quantum mechanics of the longitudinal oscillations by using a semiclassical Bohr-Sommerfeld approach. For the  $D=2$  string with an arbitrary mass distribution, we find in the massless limit a simple form for the Hamil-

tonian in terms of action variables alone. The theory of the kink solutions of the  $D=2$  string is thus a completely integrable Hamiltonian system, comparable in spirit to the classical system found by Faddeev and Takhtajan<sup>6</sup> for the sine-Gordon equation. Finally, using a gauge proposed by Rohrlich<sup>7</sup> to separate the Newton-Wigner center-of-mass coordinates of the string, we examine the Dirac bracket algebra of the fully constrained system and expose the difficulties of canonical quantization. We do not find Rohrlich's simple spectrum. An appendix gives the Dirac bracket analysis and an alternative gauge-invariant approach to the oscillators of the constrained system.

### I. MASSLESS LIMIT OF MASSIVE RELATIVISTIC SYSTEMS

Classical relativistic theories with points moving at the speed of light require extra care in the definition of the system. Here we review the theory of a massless relativistic scalar particle, so that we may later apply the resulting intuition to the string model.

We take as our Lagrangian

$$L = -\mu (-x_\tau^2)^{1/2}, \quad (1.1)$$

where

$$x_\tau^2 \equiv x_\tau^\mu g_{\mu\nu} x_\tau^\nu \equiv \frac{d\vec{x}}{d\tau} \cdot \frac{d\vec{x}}{d\tau} - \left(\frac{dx^0}{d\tau}\right)^2. \quad (1.2)$$

The canonical momenta

$$p^\alpha = \frac{\partial L}{\partial x_{\alpha,\tau}} = \frac{\mu x_\tau^\alpha}{(-x_\tau^2)^{1/2}} \quad (1.3)$$

obey the constraint

$$p^2 + \mu^2 \approx 0 \quad (1.4)$$

and have canonical Poisson brackets (PB) given by

$$\{p^\mu(\tau), x^\nu(\tau)\} = -g^{\mu\nu}. \quad (1.5)$$

In the timelike gauge

$$x^0(\tau) \approx \tau, \quad (1.6)$$

the Hamiltonian becomes

$$H = p^0 = (\vec{p}^2 + \mu^2)^{1/2}. \quad (1.7)$$

If we now take the limit  $\mu \rightarrow 0$  with  $p^\alpha$  finite, we find a finite Hamiltonian

$$H = |\vec{p}|, \quad (1.8)$$

even though the action functional *vanishes*. We also recover from Eq. (1.3) the usual result that for  $p^\alpha$  to remain finite as the particle becomes massless, the particle must move at the speed of light,

$$x_\tau^2 = 0. \quad (1.9)$$

Another approach to the massless classical re-

lativistic particle might be to consider the action functional

$$I[x] = - \int_{\tau_1}^{\tau_2} d\tau (-x_\tau^2)^{1/2}, \quad (1.10)$$

where  $x^\mu(\tau_1)$  and  $x^\mu(\tau_2)$  have a lightlike separation. If we prohibit paths connecting  $x^\mu(\tau_1)$  and  $x^\mu(\tau_2)$  which make  $(-x_\tau^2) < 0$  at any point, then there are no legal variations of the action functional; only the single lightlike path connecting the two points is permitted, and  $I[x] \equiv 0$ .

We interpret these observations as an indication that to find the correct Hamiltonian for a massless classical system, it may be necessary to begin with a massive system and take the limit as the mass goes to zero.

### II. THE MASSIVE STRING

The Nambu action<sup>1</sup> describes a relativistic massless string. Because points on the string can move at the speed of light in this theory, the Hamiltonian may contain terms of the type found in the preceding section, which do not follow from the standard variational methods.

We are thus motivated to expand the techniques of the preceding section and consider the theory of a massive relativistic string. When the string is massive, all points move with velocities less than the speed of light, so the standard methods may be applied without ambiguity to find the Hamiltonian. The Hamiltonian of the massless relativistic string is then found to be the smooth limit of the massive Hamiltonian as the mass goes to zero, as was the case for the point particle in Sec. I.

The action for a massive relativistic string is

$$S[x] = \int_{\tau_1}^{\tau_2} d\tau \int_0^\pi d\sigma [-\mu (-x_\tau^2)^{1/2} - \gamma (-G)^{1/2}], \quad (2.1)$$

which has been briefly considered by Chodos and Thorn.<sup>5</sup>  $x^\mu(\tau, \sigma)$  is a  $D$ -component field on  $(\tau, \sigma)$  space and

$$G = x_\tau^2 x_\sigma^2 - (x_\tau \cdot x_\sigma)^2. \quad (2.2)$$

We define

$$p^\alpha(\tau, \sigma) = \mu x_\tau^\alpha (-x_\tau^2)^{-1/2},$$

$$K^\alpha(\tau, \sigma) = [x_\tau^\alpha x_\sigma^2 - x_\sigma^\alpha (x_\tau \cdot x_\sigma)] (-G)^{-1/2}, \quad (2.3)$$

$$N^\alpha(\tau, \sigma) = [x_\sigma^\alpha x_\tau^2 - x_\tau^\alpha (x_\tau \cdot x_\sigma)] (-G)^{-1/2},$$

so that we may write the canonical momenta as

$$\mathcal{P}^\alpha(\tau, \sigma) = \frac{\delta S}{\delta x_{\alpha,\tau}} = p^\alpha(\tau, \sigma) + \gamma K^\alpha(\tau, \sigma), \quad (2.4)$$

where neither  $p^\alpha$  nor  $K^\alpha$  is a true canonical variable. The nonvanishing canonical Poisson brackets are

$$\{\mathcal{P}^\alpha(\tau, \sigma), x^\beta(\tau, \sigma')\} = -g^{\alpha\beta}\delta(\sigma - \sigma'), \quad (2.5)$$

and  $\mathcal{P}^\alpha$  obeys the constraint

$$\mathcal{P}^2 + 2\gamma[(\mathcal{P} \cdot x_\sigma)^2 + \mu^2 x_\sigma^2]^{1/2} + \gamma^2 x_\sigma^2 + \mu^2 \approx 0 \quad (2.6)$$

due to  $\tau$  reparametrization invariance. If we choose a timelike gauge such as  $x^0 \approx \tau$ , we find the Hamiltonian

$$\begin{aligned} H[\mu] &= \int_0^\pi d\sigma \mathcal{P}^0(\tau, \sigma) \\ &= \int_0^\pi d\sigma \{ \tilde{\mathcal{P}}^2 + 2\gamma[(\tilde{\mathcal{P}} \cdot \tilde{x}_\sigma)^2 + \mu^2 \tilde{x}_\sigma^2]^{1/2} \\ &\quad + \gamma^2 \tilde{x}_\sigma^2 + \mu^2 \}^{1/2}. \end{aligned} \quad (2.7)$$

At this point we may take the mass parameter  $\mu \rightarrow 0$  with  $\mathcal{P}^\mu(\tau, \sigma)$  fixed, yielding the Hamiltonian

$$H = \int_0^\pi d\sigma [(\tilde{\mathcal{P}} + \gamma \tilde{\mathbf{K}})^2 + 2\gamma|\tilde{\mathcal{P}} \cdot \tilde{x}_\sigma| + \gamma^2 \tilde{x}_\sigma^2]^{1/2} \quad (2.8)$$

for the massless relativistic string. This differs from the usual massless string Hamiltonian

$$H_0 = \gamma \int_0^\pi d\sigma (\tilde{\mathbf{K}}^2 + \tilde{x}_\sigma^2)^{1/2}, \quad (2.9)$$

even though the action functionals appear to be the same in this limit. To understand the difference between these two formulations of the Hamiltonian, we recall that the canonical momenta in Eq. (2.8) are given by Eq. (2.4), where  $\tilde{\mathbf{K}} \cdot \tilde{x}_\sigma$  is formally zero. When  $\tilde{\mathcal{P}} = 0$ , the two Hamiltonians are identical. However, as  $\mu \rightarrow 0$ ,  $\tilde{\mathcal{P}}(\tau, \sigma)$  need not be zero in our formulation in any region of  $\sigma$  for which the string moves at the velocity of light ( $x_\tau^2 = 0$ ), as is evident from Eq. (2.3). Our approach thus makes it apparent that the string may have more general motions than those considered in the standard treatment of GGRT.

The Nambu action is invariant under  $\sigma$  reparametrizations as well as  $\tau$  reparametrizations. Placing mass on the string as in Eq. (2.1) breaks the  $\sigma$  reparametrization invariance. However, the theory described by the Hamiltonian (2.8) regains the invariance. This may be seen by examining the generator of  $\sigma$  reparametrizations

$$\Sigma[f] = \int_0^\pi d\sigma f(\sigma) \mathcal{P} \cdot x_\sigma. \quad (2.10)$$

The function  $f(\sigma)$  is arbitrary save for the constraints

$$f(0) = f(\pi) = 0, \quad (2.11)$$

which follow from the requirement that the end points of the string map into themselves.  $x^\mu(\tau, \sigma)$  and  $\mathcal{P}^\mu(\tau, \sigma)$  transform under the action of  $\Sigma[f]$  as

$$\{x^\mu(\sigma), \Sigma[f]\} = f(\sigma) x_\sigma^\mu(\sigma), \quad (2.12)$$

$$\{\mathcal{P}^\mu(\sigma), \Sigma[f]\} = \partial_\sigma [f(\sigma) \mathcal{P}^\mu(\sigma)]. \quad (2.13)$$

One can now compute the Poisson bracket of  $H$  in Eq. (2.8) with  $\Sigma[f]$ . We find

$$\begin{aligned} \{H, \Sigma[f]\} &= \int_0^\pi d\sigma \left[ \frac{\partial \mathcal{P}^0}{\partial \tilde{x}_\sigma} \cdot \frac{\partial (f(\sigma) \tilde{x}_\sigma)}{\partial \sigma} + \frac{\partial \mathcal{P}^0}{\partial \tilde{\mathcal{P}}} \cdot \frac{\partial (f(\sigma) \tilde{\mathcal{P}})}{\partial \sigma} \right] \\ &= \int_0^\pi d\sigma \left[ f(\sigma) \frac{\partial \mathcal{P}^0}{\partial \sigma} + \frac{\partial f(\sigma)}{\partial \sigma} \left( \frac{\partial \mathcal{P}^0}{\partial \tilde{x}_\sigma} \cdot \tilde{x}_\sigma + \frac{\partial \mathcal{P}^0}{\partial \tilde{\mathcal{P}}} \cdot \tilde{\mathcal{P}} \right) \right] \\ &= \int_0^\pi d\sigma \partial [f(\sigma) \mathcal{P}^0] / \partial \sigma = 0. \end{aligned} \quad (2.14)$$

Equation (2.14) implies that  $\Sigma[f]$  is a constant of motion. Hence we will be able to use  $\sigma$  reparametrizations to further simplify the theory.

### III. MASSLESS LIMIT OF A STRING WITH MASSIVE ENDS

The general Hamiltonian for the string system proposed in the preceding section incorporates the possibility of many complex motions. To understand more clearly the properties of such motions, we devote this section to a detailed analysis of the simplest sector of the theory with  $\tilde{\mathcal{P}}(\tau, \sigma) \neq 0$ : We restrict ourselves to purely longitudinal motion and *allow only the end points to move at the speed of light in the massless limit*. To illustrate the desired motion it is sufficient to consider the simplified action

$$\begin{aligned} S[x] &= \int_{\tau_1}^{\tau_2} d\tau \left\{ -\mu[-x_\tau^2(0)]^{1/2} - \mu[-x_\tau^2(\pi)]^{1/2} \right. \\ &\quad \left. - \gamma \int_0^\pi d\sigma (-G)^{1/2} \right\} \end{aligned} \quad (3.1)$$

describing a pair of point masses joined by a string. Even for  $\mu \neq 0$ , this action is invariant under the usual invariance group of  $\sigma$  reparametrizations obeying  $\tilde{\sigma}(\tau, 0) = 0$ ,  $\tilde{\sigma}(\tau, \pi) = \pi$ . In the massless limit this theory corresponds to treating the Hamiltonian (2.8) in a specific gauge. This connection will be made clearer when we study gauge transformations between equivalent systems in Sec. IV. For  $0 < \sigma < \pi$  we find the equations of motion

$$K_\tau^\alpha + N_\sigma^\alpha = 0. \quad (3.2)$$

At the end points  $\sigma = 0$  and  $\sigma = \pi$  we have

$$\begin{aligned} p_\tau^\alpha(0) + \gamma N^\alpha(0) &= 0, \\ p_\tau^\alpha(\pi) - \gamma N^\alpha(\pi) &= 0. \end{aligned} \quad (3.3)$$

The variables  $p^\alpha$ ,  $K^\alpha$ , and  $N^\alpha$  are defined as in Eq. (2.3). The conserved total momentum is

$$P^\alpha = \int_0^\pi d\sigma \mathcal{P}^\alpha = p^\alpha(0) + p^\alpha(\pi) + \gamma \int_0^\pi d\sigma K^\alpha, \quad (3.4)$$

and the conserved Lorentz transformation generator is

$$\begin{aligned}
M^{\alpha\beta} &= \int_0^\pi d\sigma (x^\alpha \dot{\phi}^\beta - x^\beta \dot{\phi}^\alpha) \\
&= x^\alpha(0) p^\beta(0) - x^\beta(0) p^\alpha(0) + x^\alpha(\pi) p^\beta(\pi) - x^\beta(\pi) p^\alpha(\pi) + \gamma \int_0^\pi d\sigma (x^\alpha K^\beta - x^\beta K^\alpha).
\end{aligned} \tag{3.5}$$

#### A. Massive classical solutions

In order to solve the equations of motion, we must fix the gauge to eliminate arbitrary functions. Choosing the timelike gauge

$$x^0 \approx \tau \tag{3.6}$$

to fix the scale of  $\tau$ , we find the Hamiltonian

$$H = [\tilde{p}^2(0) + \mu^2]^{1/2} + [\tilde{p}^2(\pi) + \mu^2]^{1/2} + \gamma \int_0^\pi d\sigma [\tilde{K}^2(\sigma) + \tilde{x}_\sigma^2(\sigma)]^{1/2}. \tag{3.7}$$

If we consider only longitudinal motions, so that we are effectively in two spacetime dimensions, then  $\tilde{K} = 0$ ,  $\tilde{x}_\tau \equiv x_\tau$ , and  $\tilde{x}_\sigma \equiv x_\sigma$ , giving

$$H = [p^2(0) + \mu^2]^{1/2} + [p^2(\pi) + \mu^2]^{1/2} + \gamma \int_0^\pi d\sigma |x_\sigma|. \tag{3.8}$$

The Euler equations (3.2) and (3.3) which we must solve are<sup>5</sup>

$$\frac{\partial}{\partial \sigma} \left[ \frac{x_\sigma}{(x_\sigma^2)^{1/2}} \right] = 0, \quad 0 < \sigma < \pi \tag{3.9a}$$

$$\frac{\partial}{\partial \tau} \left[ \frac{\mu x_\tau}{(1 - x_\tau^2)^{1/2}} \right] \mp \frac{\gamma x_\sigma}{(x_\sigma^2)^{1/2}} = 0, \quad \begin{cases} \sigma = 0 \\ \sigma = \pi. \end{cases} \tag{3.9b}$$

Using Eq. (3.9a) and  $\sigma$  reparametrization invariance, we see that we can make  $x_\sigma(\tau, \sigma)$  independent of  $\sigma$  for  $0 < \sigma < \pi$ , so that<sup>8</sup>

$$\int_0^\pi d\sigma |x_\sigma| = |x(\tau, \pi) - x(\tau, 0)|. \tag{3.10}$$

The Hamiltonian (3.8) then becomes

$$H = [p^2(0) + \mu^2]^{1/2} + [p^2(\pi) + \mu^2]^{1/2} + \gamma |x(\pi) - x(0)|. \tag{3.11}$$

We can check classical Poincaré invariance of the two-spacetime-dimensional system by using Eq. (3.5) to derive the boost generator

$$B \equiv M^{01} = \tau(p(0) + p(\pi)) - x(0)[p^2(0) + \mu^2]^{1/2} - x(\pi)[p^2(\pi) + \mu^2]^{1/2} - \frac{1}{2} \gamma (x(0) + x(\pi)) |x(\pi) - x(0)|. \tag{3.12}$$

Taking the total momentum  $P = p(0) + p(\pi)$  from Eq. (3.4), we verify the Poincaré group Poisson bracket (PB) algebra

$$\begin{aligned}
\{P, H\} &= 0, \\
\{B, P\} &= -H, \\
\{B, H\} &= -P.
\end{aligned}$$

The Hamiltonian (3.11) therefore describes a classically Poincaré-invariant system.

The solutions of the Euler equations are now of the form

$$x(\tau, \sigma) = \pm \left( \frac{2\sigma}{\pi} - 1 \right) \left\{ - [(\tau - \tau_0)^2 + \mu^2/\gamma^2]^{1/2} + (\pi^2/4 + \mu^2/\gamma^2)^{1/2} \right\} \tag{3.13}$$

in the rest frame, where  $P = p(0) + p(\pi) = 0$ . For  $-\frac{1}{2}\pi < \tau < \frac{1}{2}\pi$  one chooses the (+) sign and sets  $\tau_0 = 0$ ; this solution joins continuously onto the next  $\tau$  region as shown in Fig. 1 provided that for  $\frac{1}{2}\pi < \tau < \frac{3}{2}\pi$ , one chooses  $\tau_0 = \pi$  and the (-) sign, etc.

We observe that at  $\sigma = 0$  and  $\sigma = \pi$

$$(1 - x_\tau^2)^{1/2} = (\mu/\gamma) [(\tau - \tau_0)^2 + \mu^2/\gamma^2]^{-1/2}, \tag{3.14}$$

so that the first term in the  $\sigma = 0, \pi$  boundary condition (3.9b) remains finite as  $\mu \rightarrow 0$ . For any  $\mu$

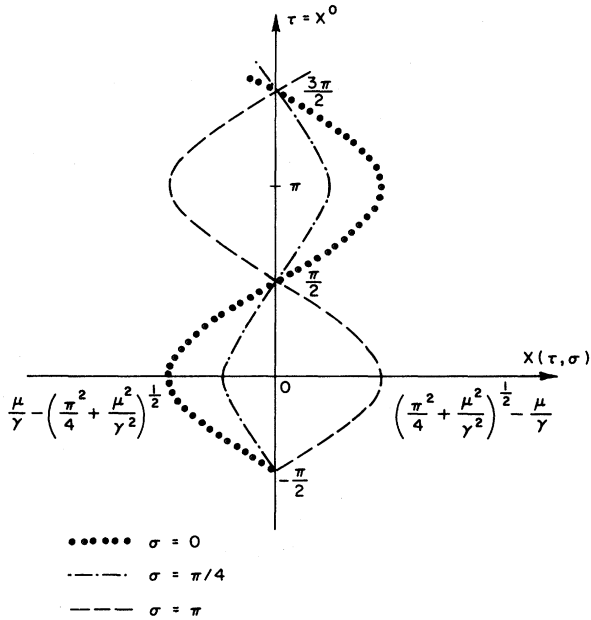

FIG. 1. Solution of the two-dimensional string equations with masses at the ends only.

the momentum of the end points is thus

$$p(\sigma=0, \pi) = \pm \gamma(\tau - \tau_0). \tag{3.15}$$

In Fig. 2, we plot  $p(0)$ ,  $p(\pi)$ , and  $x_\sigma(\sigma)$  as a function of  $\tau$ .

B. Massless limit

In the massless limit our Hamiltonian (3.8) with the gauge choice (3.10) becomes

$$H = |p_0| + |p_\pi| + \gamma |x_\pi - x_0|, \tag{3.16}$$

where  $x_0 = x(\tau, \sigma=0)$ , etc. It is amusing to observe that the potential energy in this Hamiltonian has precisely the form of a one-space-dimension Coulomb potential, so this system is closely related to the two-spacetime-dimensional relativistic "hydrogen atom." Examining the  $\mu \rightarrow 0$  limit of the classical rest-frame solution (3.13), we find

$$x(\tau, \sigma) = \pm \left(1 - \frac{2\sigma}{\pi}\right) (|\tau - \tau_0| - \frac{1}{2}\pi), \tag{3.17}$$

while Eq. (3.15) for the momentum continues to be valid. The resulting motion is pictured in Fig. 3. This motion will be shown in Sec. IV to be identi-

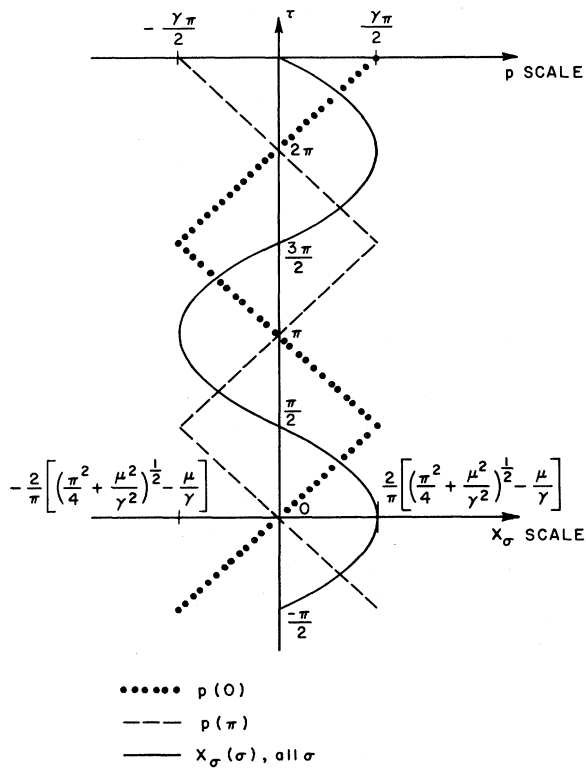

FIG. 2.  $\tau$  dependence of  $p(0)$ ,  $p(\pi)$ , and  $x_\sigma(\sigma)$  for the string with massive ends.

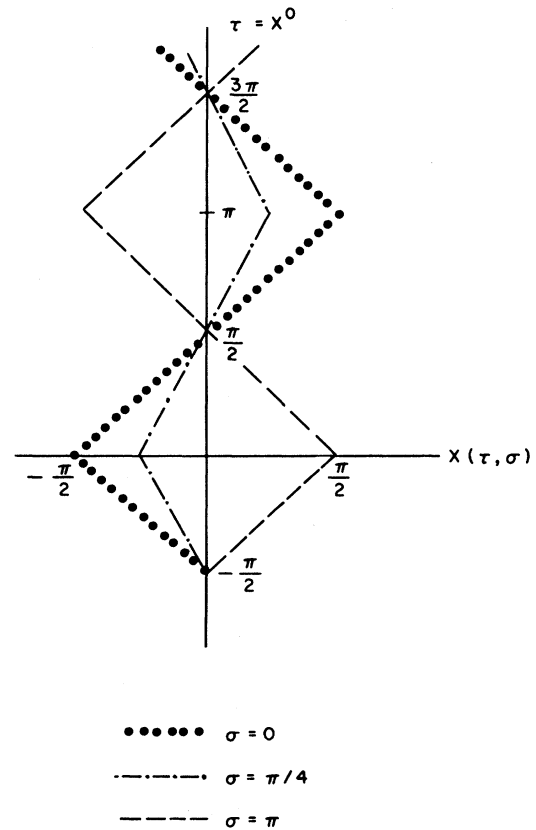

FIG. 3. Massless-limit solution of the two-dimensional massive-end string.

cal to the simplest longitudinal string mode proposed by Patrascioiu.<sup>4</sup>

C. Action-angle variables and Bohr-Sommerfeld quantization

We now exhibit the center-of-mass momentum  $P$  of the system by changing to the variables

$$\begin{aligned} P &= p_0 + p_\pi, \\ R &= \frac{1}{2}(x_0 + x_\pi), \\ k &= \frac{1}{2}(p_\pi - p_0), \\ r &= x_\pi - x_0. \end{aligned} \tag{3.18}$$

Then the Hamiltonian (3.14) becomes

$$H = \left| \frac{1}{2}P - k \right| + \left| \frac{1}{2}P + k \right| + \gamma|r|. \tag{3.19}$$

Hamilton's equations now tell us that

$$\begin{aligned} \dot{r} &= \frac{\partial H}{\partial k} = \epsilon(k - \frac{1}{2}P) + \epsilon(k + \frac{1}{2}P), \\ \dot{k} &= -\frac{\partial H}{\partial r} = -\gamma\epsilon(r), \end{aligned} \tag{3.20}$$

where  $\epsilon(z) = (\text{algebraic sign of } z) = z/|z|$ . When we plot the motion in  $\tau$  for arbitrary initial energy  $H = E$  and momentum  $P$ , Eq. (3.19) generates the closed phase-space trajectory of Fig. 4. In the rest frame the total momentum  $P$  vanishes, and the vertical lines at constant  $r$  in Fig. 4 disappear. We now define the action variable

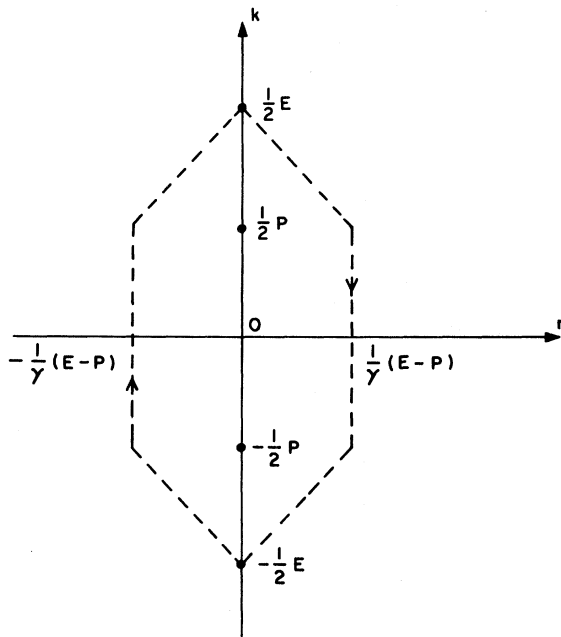

FIG. 4. Phase-space orbit of the massless string with Hamiltonian (3.19). The arrows give the direction of increasing time.

$$J = \oint k dr, \tag{3.21}$$

where the integral is around the path of Fig. 4 and  $k(E)$  is the solution of

$$E = \left| \frac{1}{2}P - k \right| + \left| \frac{1}{2}P + k \right| + \gamma|r|. \tag{3.22}$$

The result is

$$\begin{aligned} J &= 4 \int_0^{\gamma^{-1}(E-P)} dr \left[ \frac{1}{2}(E - \gamma r) \right] \\ &= \frac{1}{\gamma}(E^2 - P^2). \end{aligned} \tag{3.23}$$

The invariant mass squared is thus

$$M^2 \equiv E^2 - P^2 = \gamma J, \tag{3.24}$$

and  $J$  is manifestly Lorentz-invariant.

The Bohr-Sommerfeld approximation for the quantum-mechanical energy levels of the center-of-mass system is simply

$$M^2 = \gamma J = 2\pi\hbar\gamma(n + \text{const}), \quad n = 0, 1, 2, \dots \tag{3.25}$$

The mass-squared spectrum of this sector of the longitudinal massless string thus rises linearly with  $n$  in this semiclassical approximation.

The exact quantum-mechanical mass spectrum of this system is presumably given by setting  $P=0$  and examining the integral equation

$$(2|k_{\text{op}}| + \gamma|r|) \psi(r, t) = M\psi(r, t). \tag{3.26}$$

Here we may represent  $|k_{\text{op}}|$  as

$$|k_{\text{op}}| \psi(r, t) = \int_{-\infty}^{\infty} dr' G(r, r') \psi(r', t), \tag{3.27}$$

where

$$\begin{aligned} G(r, r') &= \lim_{\epsilon \rightarrow 0} \frac{1}{\pi} \int_0^{\infty} dk k \cos k(r - r') e^{-\epsilon k} \\ &= P \left[ \frac{1}{\pi(r - r')^2} \right] \end{aligned} \tag{3.28}$$

and  $P$  denotes the principal value.

D. Lightlike gauge

Throughout the preceding treatment we have employed the timelike gauge  $x^0 \approx \tau$ . Since the usual GGRT analysis is conducted in the lightlike gauge, one might ask what happens when we use a lightlike gauge to study longitudinal modes. Defining  $x^\pm = (x^0 \pm x)/\sqrt{2}$ , let us begin by choosing the gauge

$$x^+(\tau, \sigma) \approx \tau. \tag{3.29}$$

In the  $x^+$ -uniform gauge the action (3.1) then yields the Hamiltonian

$$H \equiv P^- = \frac{\mu^2}{2p_0} + \frac{\mu^2}{2p_\pi} + \gamma|x_\pi - x_0|, \quad (3.30)$$

where we have written

$$\begin{aligned} p_0 &= p^+(\tau, \sigma=0) \geq 0, & p_\pi &= p^+(\tau, \sigma=\pi) \geq 0, \\ x_0 &= x^-(\tau, \sigma=0), & x_\pi &= x^-(\tau, \sigma=\pi). \end{aligned} \quad (3.31)$$

Now we define the total (+) momentum

$$P \equiv P^+ = p_0 + p_\pi \quad (3.32)$$

and make the canonical transformation (3.18) with null-plane metric variables replacing the timelike variables. The Hamiltonian then becomes

$$H = \frac{1}{2} \mu^2 P \left( \frac{1}{4} P^2 - k^2 \right)^{-1} + \gamma |\rho|. \quad (3.33)$$

The invariant mass squared is simply<sup>9</sup>

$$M^2 = 2PH = \frac{\mu^2}{\frac{1}{4} - k^2} + 2\gamma |\rho|, \quad |\kappa| \leq \frac{1}{2} \quad (3.34)$$

where the transformation

$$\kappa = k/P, \quad \rho = \gamma P \quad (3.35)$$

has eliminated all reference to  $P$  and made Lorentz invariance manifest.

It is clear that the  $\mu \rightarrow 0$  limit of the lightlike gauge description of this system is quite pathological, in contrast to the timelike gauge. However, the semiclassical spectrum of  $M^2$  agrees with that found in the timelike gauge. We can see this explicitly by calculating the action-angle variables for  $\mu \neq 0$  using the standard techniques. We find the result

$$\begin{aligned} J &= 2P \int_0^{E\gamma^{-1}(1-2\mu^2/EP)} d\tau \left[ 1 - \frac{2\mu^2}{P(E-\gamma\tau)} \right]^{1/2} \\ &= \frac{1}{\gamma} \left[ 2PE\alpha - 2\mu^2 \ln \left( \frac{1+\alpha}{1-\alpha} \right) \right] \\ &= \frac{1}{\gamma} \left\{ M(M^2 - 4\mu^2)^{1/2} - 4\mu^2 \ln \left[ \frac{M}{2\mu} + \left( \frac{M^2}{4\mu^2} - 1 \right)^{1/2} \right] \right\}, \end{aligned} \quad (3.36)$$

where

$$\alpha = (1 - 2\mu^2/EP)^{1/2}. \quad (3.37)$$

The variable  $J$  is well behaved as  $\mu^2 \rightarrow 0$ , giving

$$M^2 = 2PE = \gamma J, \quad (3.38)$$

so the Bohr-Sommerfeld quantum spectrum is the same as in the timelike case.

#### IV. COMPARISON TO ORTHONORMAL-GAUGE RESULTS

The motion shown in Fig. 3 strongly resembles a class of solutions to the massless string studied by Patrascioiu<sup>4</sup> in a timelike orthonormal gauge. In this section we will review Patrascioiu's ortho-

normal-gauge analysis and show that his solutions can be mapped identically into ours by an appropriate gauge transformation.

##### A. Orthonormal gauges

We begin by reviewing the properties of the orthonormal gauge. We recall that the orthonormality conditions

$$\begin{aligned} x_\tau^2 + x_\sigma^2 &= 0, \\ x_\tau \cdot x_\sigma &= 0 \end{aligned} \quad (4.1)$$

allow the massless string Euler equations to be written as

$$x_{\tau\tau}^\mu - x_{\sigma\sigma}^\mu = 0, \quad (4.2)$$

$$x_\sigma^\mu = 0, \quad \text{at } \sigma = 0, \pi. \quad (4.3)$$

These equations can then be solved in the form

$$x^\mu(\tau, \sigma) = q^\mu + \frac{P^\mu \tau}{\pi\gamma} + \frac{i}{\pi\gamma} \sum_{n \neq 0} \frac{1}{n} \alpha_n^\mu \cos n\sigma e^{-in\tau} \quad (4.4)$$

subject to the constraints

$$L_0 = \frac{1}{2} \sum_{m \neq 0} \alpha_m \cdot \alpha_{-m} + \frac{1}{2} P^2 = 0, \quad (4.5)$$

$$L_n = \frac{1}{2} \sum_{m \neq 0, n} \alpha_m \cdot \alpha_{n-m} + P \cdot \alpha_n = 0.$$

In the orthonormal gauge the canonical momentum is simply

$$\mathcal{P}^\mu(\tau, \sigma) = \gamma x_\tau^\mu(\tau, \sigma). \quad (4.6)$$

If we take the nonvanishing canonical PB of the Fourier components of  $x^\mu$  to be

$$\begin{aligned} \{P^\mu, q^\nu\} &= -g^{\mu\nu}, \\ \{\alpha_m^\mu, \alpha_n^\nu\} &= -i\pi\gamma g^{\mu\nu} m \delta_{m, -n}, \end{aligned} \quad (4.7)$$

then the equal- $\tau$  PB of  $\mathcal{P}^\mu$  and  $x^\nu$  are

$$\{\mathcal{P}^\mu(\tau, \sigma), x^\nu(\tau, \sigma')\} = -g^{\mu\nu} \Delta(\sigma, \sigma'). \quad (4.8)$$

Here

$$\begin{aligned} \Delta(\sigma, \sigma') &= \sum_{n=-\infty}^{\infty} [\delta(\sigma - \sigma' + 2n\pi) \\ &\quad + \delta(\sigma + \sigma' + 2n\pi)] \end{aligned} \quad (4.9)$$

is just that modification of the periodic  $\delta$  function necessary for compatibility with the boundary condition (4.3).

##### B. Simple longitudinal motions

Patrascioiu has observed that a general solution to Eqs. (4.1)–(4.3) is

$$x^0 = \tau E / \pi\gamma, \quad (4.10)$$

$$\vec{x}(\tau, \sigma) = \vec{a} + \frac{E}{2\pi\gamma} [\vec{f}(\tau + \sigma) + \vec{f}(\tau - \sigma)]$$

provided

$$\begin{aligned} \vec{f}'(\tau+2\pi) &= \vec{f}'(\tau), \\ [\vec{f}'(\tau+\sigma)]^2 &= [\vec{f}'(\tau-\sigma)]^2 = 1, \end{aligned} \tag{4.11}$$

where  $\vec{f}'(z) = \partial \vec{f} / \partial z$ . We note that

$$\begin{aligned} \vec{\mathcal{P}}(\tau, \sigma) &= \gamma \vec{x}_\tau \\ &= \frac{E}{2\pi} [\vec{f}'(\tau+\sigma) + \vec{f}'(\tau-\sigma)], \end{aligned} \tag{4.12}$$

$$\vec{x}_\sigma(\tau, \sigma) = \frac{E}{2\pi\gamma} [\vec{f}'(\tau+\sigma) - \vec{f}'(\tau-\sigma)].$$

The conserved total momentum may thus be written as

$$\begin{aligned} \vec{P} &= \int_0^\pi d\sigma \vec{\mathcal{P}}(\tau, \sigma) \\ &= \frac{E}{2\pi} [\vec{f}(\tau+\pi) - \vec{f}(\tau-\pi)] \end{aligned} \tag{4.13}$$

for arbitrary  $\tau$ .

Suppose we now choose the simplest rest-frame solution

$$a \equiv a^{(1)} = -E/2\gamma,$$

$$f(z) \equiv f^{(1)}(z) = |z|_{\text{periodic}} = \sum_{n=-\infty}^{\infty} c_n e^{inz}, \tag{4.14}$$

$$a^{(i)} = f^{(i)} = 0, \quad i \neq 1$$

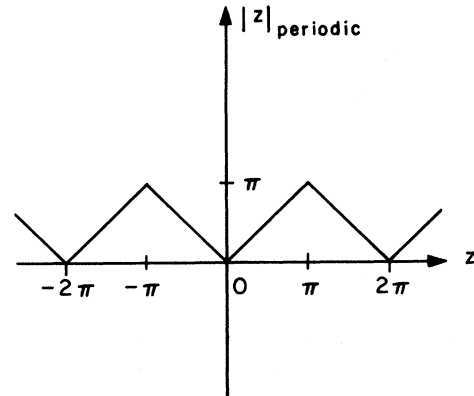

FIG. 5. Plot of periodic absolute-value function, Eq. (4.14).

where

$$c_n = \frac{1}{\pi n^2} [(-1)^n - 1], \tag{4.15}$$

$$c_0 = \frac{1}{2} \pi.$$

We now show that this motion is precisely that shown in Fig. 3 and examined in Sec. III as the massless limit of the string with massive ends. Working from the plot of  $f(z)$  in Fig. 5, we may construct  $\mathcal{P}(\tau, \sigma)$ ,  $x(\tau, \sigma)$ ,  $x_\sigma(\tau, \sigma)$  for appropriate values of  $\tau$  to find the motions presented in Fig. 6.

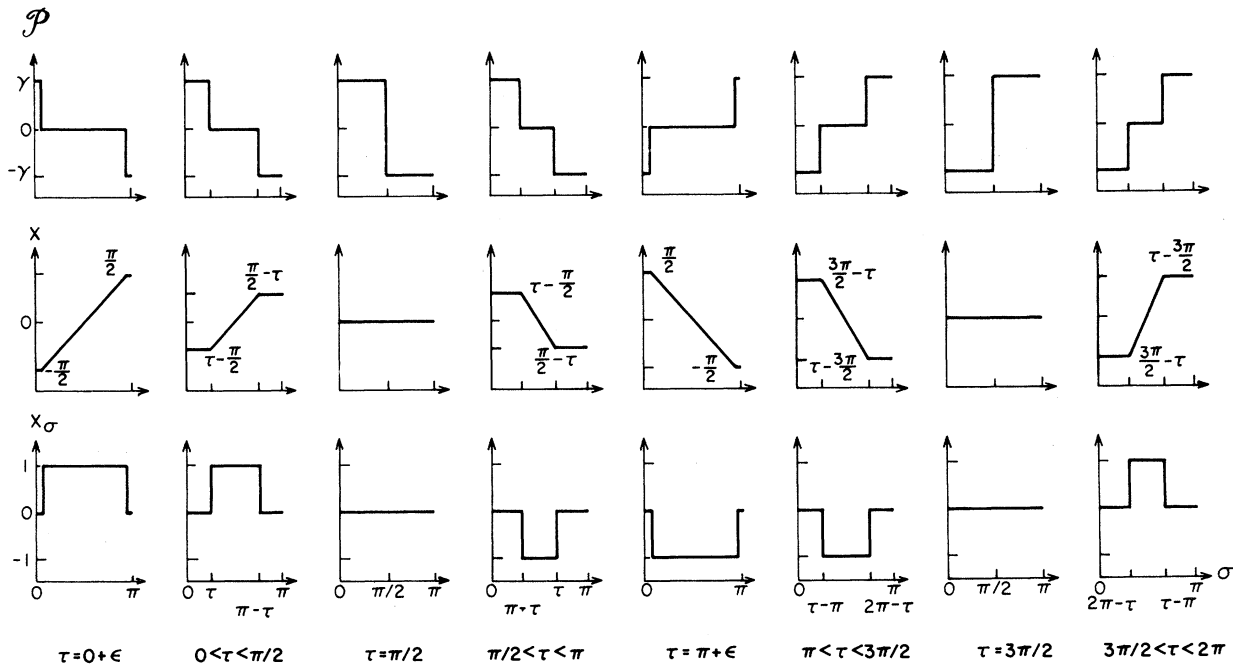

FIG. 6. Plot of  $\mathcal{P}$ ,  $x$ ,  $x_\sigma$  versus  $\sigma$  at successive values of  $\tau$  for simplest rest-frame solution of orthonormal-gauge string equations.



We can thus see directly how this solution contrives to have  $\mathcal{P}x_\sigma=0$  without forcing either  $\mathcal{P}\equiv 0$  or  $x_\sigma\equiv 0$ . If we follow the motion of the end points in Fig. 6, we find that the end points of our solution, shown in Fig. 3, follow the same paths. The motion of the end points is physical and cannot be gauged away, so we conclude that the physical meanings of the two pictures are very likely the same.

The motions of the interior points in Figs. 3 and 6 differ because this motion depends on the  $\sigma$  gauge chosen. We can complete the identification of the two systems by making a  $\sigma$  reparametrization which maps the orthonormal gauge into the uniform- $x_\sigma$  gauge. The appropriate transformation is found by requiring

$$x(\tau, \sigma) = \tilde{x}(\tau, \tilde{\sigma}(\tau, \sigma)) \quad (4.16)$$

and taking the  $\sigma$  derivative

$$x_\sigma = \frac{\partial \tilde{x}}{\partial \tilde{\sigma}} \tilde{x}_{\tilde{\sigma}}. \quad (4.17)$$

Now suppose  $x_\sigma$  is in the orthonormal gauge (uniform  $\mathcal{P}^0$ ) but  $\tilde{x}_{\tilde{\sigma}}$  is independent of  $\tilde{\sigma}$  (uniform- $x_\sigma$  gauge). Then we can evaluate the integral immediately, finding

$$\tilde{\sigma}(\tau, \sigma) = F(\tau) \int_0^\sigma d\rho x_\rho(\tau, \rho), \quad (4.18)$$

where  $F(\tau) = (\tilde{x}_{\tilde{\sigma}})^{-1}$ . The requirement that the end points stay fixed,

$$\begin{aligned} \tilde{\sigma}(\tau, 0) &= 0, \\ \tilde{\sigma}(\tau, \pi) &= \pi, \end{aligned} \quad (4.19)$$

then fixes the function  $F(\tau)$  uniquely, giving

$$\tilde{\sigma}(\tau, \sigma) = \pi \frac{\int_0^\sigma d\rho x_\rho(\tau, \rho)}{\int_0^\pi d\rho x_\rho(\tau, \rho)}. \quad (4.20)$$

Taking  $x_\sigma(\tau, \sigma)$  from Fig. 6, we plot  $\tilde{\sigma}(\tau, \sigma)$  in Fig. 7.

The effect of this transformation is clearly to map the finite-width plateaus in  $\mathcal{P}$  and the zero

regions of  $x_\sigma$  in Fig. 6 into the end points  $\tilde{\sigma}=0, \tilde{\sigma}=\pi$  of the new system. For example, when  $0 < \tau < \frac{1}{2}\pi$ ,  $\tilde{\sigma}$  vanishes for the entire interval  $0 < \sigma < \tau$ , where  $x_\sigma=0$  and  $\mathcal{P}\neq 0$ .

If we define the momentum accumulating near an end point as

$$p_0(\tau) = \int_0^{\pi/2} d\sigma \mathcal{P}(\sigma) \quad (4.21)$$

in the orthonormal gauge, we see from Fig. 6 that  $p_0$  increases linearly with  $\tau$  for  $0 < \tau < \frac{1}{2}\pi$ . In the  $x_\sigma$ -uniform gauge,  $\tilde{\mathcal{P}}(\tilde{\sigma})$  vanishes except at  $\tilde{\sigma}=0, \pi$ , so  $\tilde{\mathcal{P}}(\tilde{\sigma})$  necessarily becomes proportional to a  $\delta$  function at the end points.  $p_0(\tau)$  is thus precisely identifiable with our end-point momentum (3.15), which does indeed change linearly with time.

In Fig. 8 we plot the new functions  $\tilde{\mathcal{P}}(\tilde{\sigma}), \tilde{x}_{\tilde{\sigma}}(\tilde{\sigma})$  versus  $\tilde{\sigma}$  and  $\tau$ . Comparison to the properties of our solution (3.17) for the  $\mu \rightarrow 0$  limit of the massive-end string shows that the motions are identical. Having demonstrated the equivalence of the orthonormal gauge and  $x_\sigma$ -uniform gauge treatment, we remark that the latter approach has a more obvious physical interpretation; the system consists solely of massless point particles interacting via linear potentials.

### C. Longitudinal Fourier components

Because of Eq. (4.11), the longitudinal solutions are not linearly superimposable and behave like *kink solutions* of a nonlinear field theory. In fact, if we identify the coefficients in Eq. (4.4) with those in Eqs. (4.14) and (4.15), we find

$$\begin{aligned} q = P &= 0, \\ i\alpha_n = Enc_n &= \frac{E}{\pi n} [(-1)^n - 1], \end{aligned} \quad (4.22)$$

so that the extraction of quantizable amplitudes from the Fourier coefficients of the classical solution is nontrivial.

It is instructive to note that the solution (4.22) satisfies the constraints (4.5) in an unusual nonlinear manner. For  $L_0$  we find

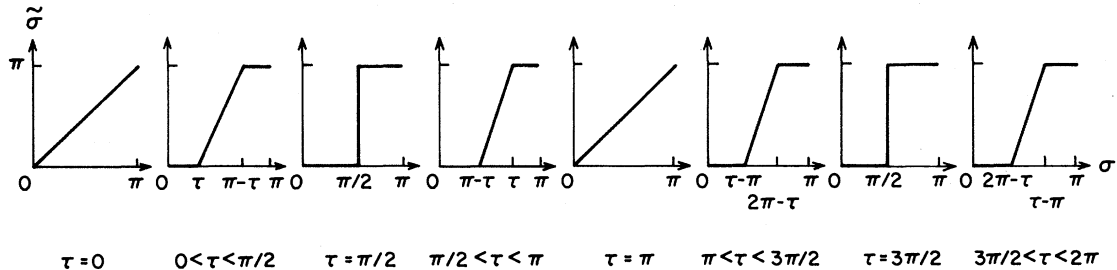

FIG. 7. Mapping from orthonormal-gauge parameter  $\sigma$  to the  $x_\sigma$ -uniform-gauge parameter  $\tilde{\sigma}(\tau, \sigma)$  at successive values of  $\tau$ .

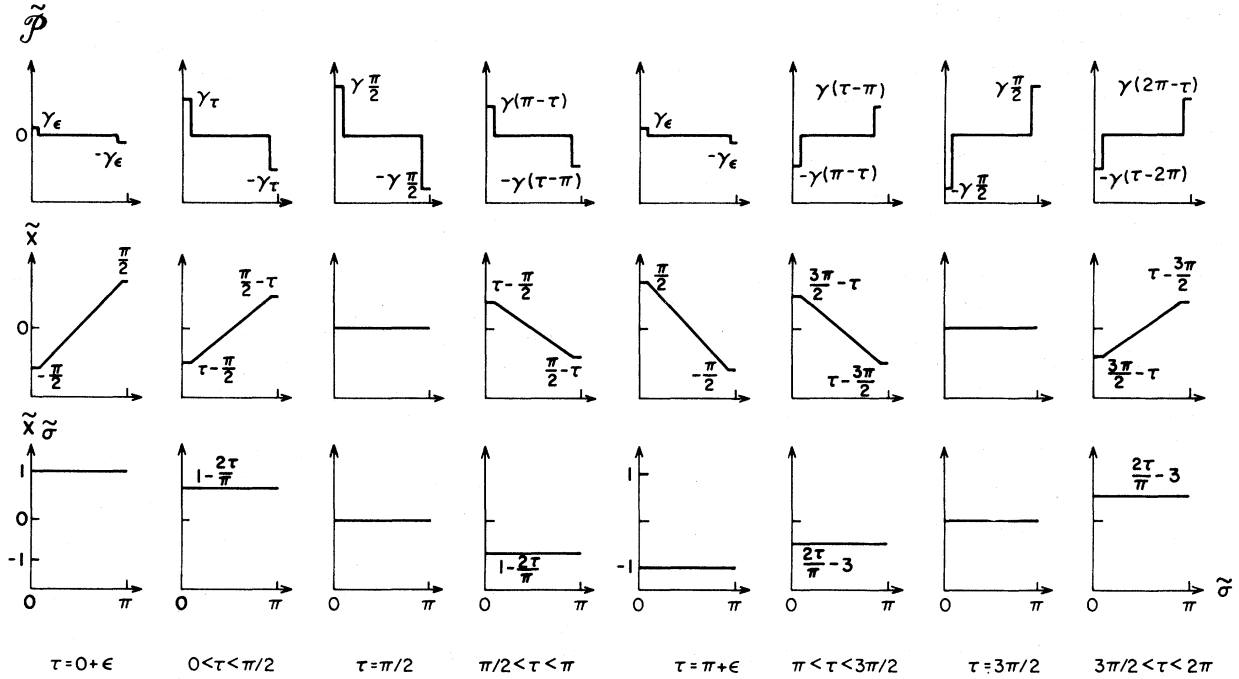

FIG. 8. Plots of  $\tilde{\mathcal{P}}$ ,  $\tilde{x}$ ,  $\tilde{x}_G$  in  $x_G$ -uniform gauge versus  $\tilde{\sigma}$  at successive values of  $\tau$ . Heights of  $\tilde{\mathcal{P}}(0)$ ,  $\tilde{\mathcal{P}}(\pi)$  give the coefficient of the appropriate  $\delta$  function.

$$\begin{aligned}
 \left(\frac{2\pi^2}{E^2}\right) L_0 &= \frac{\pi^2}{E^2} \sum_{m \neq 0} \alpha_m \alpha_{-m} - \pi^2 \\
 &= 4 \sum_{m=1}^{\infty} \frac{1}{m^2} [1 - (-1)^m] - \pi^2 \\
 &= 6\zeta(2) - \pi^2 \equiv 0, \quad (4.23)
 \end{aligned}$$

where  $\zeta(n)$  is the Riemann  $\zeta$  function. Examining  $L_n$ ,  $n \neq 0$  we see that

$$\begin{aligned}
 \left(\frac{2\pi^2}{E^2}\right) L_n &= \frac{\pi^2}{E^2} \sum_{m \neq 0, n} \alpha_m \alpha_{n-m} \\
 &= [1 + (-1)^n] \sum_{m \neq 0, n} \frac{(-1)^m - 1}{m(n-m)}, \quad (4.24)
 \end{aligned}$$

which vanishes trivially for odd  $n$ . For even  $n$  one may use

$$\frac{1}{m(n-m)} = \frac{1}{n} \left( \frac{1}{m} + \frac{1}{n-m} \right) \quad (4.25)$$

and the fact that  $(-1)^{m+n} = (-1)^m$  to prove that there is a cancellation of terms in the sum which makes  $L_n \equiv 0$ .

#### D. $N$ -fold longitudinal solutions

We saw in the beginning of this section that the simplest longitudinal solution (4.14) of the constraint Eq. (4.11) corresponded to our solution (3.17) with only the end points of the string moving at the speed of light. More general solutions

for  $f(z)$  give longitudinal motions with arbitrary numbers of interior points moving at the speed of light.

The only restrictions on  $f'(z)$  are that it be periodic and have unit magnitude. If we confine ourselves to the rest frame  $\vec{\mathcal{P}}=0$ , then Eq. (4.13) implies that  $f(z)$  itself has period  $2\pi$ . Wherever there is a discontinuity in the slope of  $f(z)$ , there is a point moving at the speed of light; we will hereafter refer to these points as "folds."

In Fig. 9 we depict  $f(z)$  for a mode which has  $N$  folds; for simplicity, we have chosen  $f(z) = f(-z)$  so that the initial  $\sigma$  positions

$$c_n, \quad n = 1, \dots, N$$

of each discontinuity are identifiable with the initial position of each fold. For this solution the initial momentum density  $\mathcal{P}(0, \sigma)$  vanishes for all  $\sigma$ . More general choices for  $f(z)$ , with  $f(z) \neq f(-z)$ , have  $2N$  free parameters giving nontrivial initial momentum configurations.

#### V. HAMILTONIAN APPROACH TO $N$ -FOLD MODES

In the preceding two sections we examined the Hamiltonian for longitudinal oscillations of the string with end points only moving at the speed of light and related that motion to a particular solution of the orthonormal-gauge string equations. Motivated by the existence of  $N$ -fold solutions in

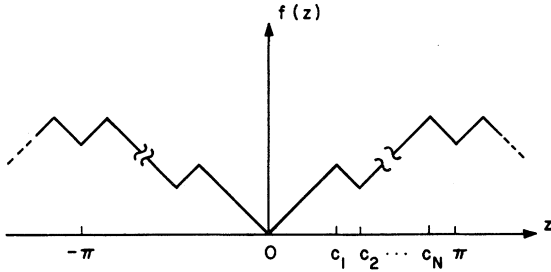

FIG. 9. A more general solution  $f(z)$  of the constraints (4.11). The projection on the vertical axis represents a string at  $\tau=0$  with  $N$  folds moving at the speed of light.

the orthonormal gauge, we now turn our attention to the Hamiltonian description of longitudinal string oscillations with  $N$  interior points moving at the velocity of light.

For pure longitudinal modes the Hamiltonian (2.8) can be written

$$H = \int_0^\pi d\sigma [ |p(\tau, \sigma)| + \gamma |x_\sigma(\tau, \sigma)| ], \quad (5.1)$$

where a  $\sigma$  gauge remains to be chosen. We argued in Sec. II that  $p(\tau, \sigma)$  remains nonzero in the massless limit only in those  $\sigma$  regions where the string moves at the velocity of light. By making a suitable choice of  $\sigma$  gauge, we may write  $H$  in the form

$$H = \sum_{n=0}^{N+1} |p_n| + \gamma \sum_{n=0}^N |x_{n+1} - x_n|, \quad (5.2)$$

where  $x_0 = x(\sigma=0)$ ,  $x_{N+1} = x_\pi = x(\sigma=\pi)$ , and similarly for  $p_0$  and  $p_{N+1}$ . Here  $x_n(\tau)$  labels the  $n$ th point moving at the velocity of light along the string, and  $p_n(\tau)$  its conjugate momentum.

In this section we will first analyze the motion and action-angle variables for the one-fold mode. Then we give the form of the general  $N$ -fold Hamiltonian expressed in terms of action variables alone.

#### A. One-fold mode

The string with one interior point moving at the velocity of light is described by the Hamiltonian

$$H = |p_0| + |p_1| + |p_\pi| + \gamma |x_1 - x_0| + \gamma |x_\pi - x_1|. \quad (5.3)$$

It is convenient to rewrite the above in terms of a set of relative coordinates and momenta. Defining the new coordinates and momenta

$$\begin{aligned} r_1 &= x_1 - x_0, \\ r_2 &= x_\pi - x_1, \\ R &= \frac{1}{3}(x_0 + x_1 + x_\pi), \end{aligned} \quad (5.4)$$

and

$$\begin{aligned} k_1 &= \frac{1}{3}(-2p_0 + p_1 + p_\pi), \\ k_2 &= \frac{1}{3}(-p_0 - p_1 + 2p_\pi), \\ P &= p_0 + p_1 + p_\pi, \end{aligned} \quad (5.5)$$

we find that the Hamiltonian takes the form

$$H = \left| \frac{1}{3}P - k_1 \right| + \left| \frac{1}{3}P + k_1 - k_2 \right| + \left| \frac{1}{3}P + k_2 \right| + \gamma |r_1| + \gamma |r_2|. \quad (5.6)$$

Hence in the  $P=0$  frame the Hamiltonian reduces to

$$H(P=0) = M = |k_1| + |k_2 - k_1| + |k_2| + \gamma |r_1| + \gamma |r_2|. \quad (5.7)$$

Yet another set of interesting variables is the choice

$$\begin{aligned} k_\pm &= k_1 \pm k_2, \\ r_\pm &= \frac{1}{2}(r_1 \pm r_2). \end{aligned} \quad (5.8)$$

In this case

$$M = \frac{1}{2}|k_+ + k_-| + \frac{1}{2}|k_+ - k_-| + |k_-| + \gamma |x_+ + x_-| + \gamma |x_+ - x_-|. \quad (5.9)$$

To proceed with the Bohr-Sommerfeld quantization, we must analyze the most general periodic motions in phase space. We begin by choosing the initial conditions

$$\begin{aligned} k_1 &= k_2 = 0, \\ r_1 &= -\frac{mc}{\pi\gamma}, \\ r_2 &= (\pi - c)\frac{m}{\pi\gamma}, \end{aligned} \quad (5.10)$$

where  $m$  is the rest mass and  $c$  corresponds to another constant of the motion. This particular choice of initial configuration is suggested by the type of one-fold orthonormal-gauge solution discussed in Sec. IV D for which all momenta initially vanish. Hamilton's equations of motion determine the subsequent periodic motion of the system, which we plot in phase space in Fig. 10. If we calculate the action-angle variables in  $(x_1, k_1; x_2, k_2)$  space, we find that  $J_1$  and  $J_2$  are independent of  $c$ :

$$\begin{aligned} J_1 &= \oint k_1 dr_1 = m^2/2\gamma, \\ J_2 &= \oint k_2 dr_2 = m^2/2\gamma. \end{aligned} \quad (5.11)$$

This is expected because of the exact symmetry of the Hamiltonian (5.7) under 1 ↔ 2 interchange.

A typical phase-space diagram in  $(k_{\pm}, r_{\pm})$  space is given in Fig. 11. The exhibited  $\tau$  sequence of numbers corresponds to the initial conditions (5.10). The action variables  $J_+$  and  $J_-$  computed by integrating over these phase-space orbits depend explicitly on  $c$ ; moreover, the regions  $0 < c < \frac{1}{3}\pi$ ,  $\frac{1}{3}\pi < c < \frac{2}{3}\pi$ ,  $\frac{2}{3}\pi < c < \pi$  must be treated separately. For arbitrary  $c$  one finds the result

$$J_{\pm} = \oint k_{\pm} dr_{\pm} = \frac{m^2}{\gamma} \left[ \frac{1}{2} \pm g(c) \right], \tag{5.12}$$

where

$$g(c) = \frac{7}{2} \frac{c}{\pi} \left( \frac{c}{\pi} - 1 \right) + \frac{3}{2} \left( \left| \frac{c}{\pi} - \frac{2}{3} \right| + \left| \frac{c}{\pi} - \frac{1}{3} \right| \right) - \frac{9}{2} \left| \frac{c}{\pi} - \frac{2}{3} \right| \left| \frac{c}{\pi} - \frac{1}{3} \right|. \tag{5.13}$$

We plot  $J_{\pm}$  vs  $c$  in Fig. 12. Now we may eliminate the constant of motion  $c$  to determine  $M^2$  uniquely

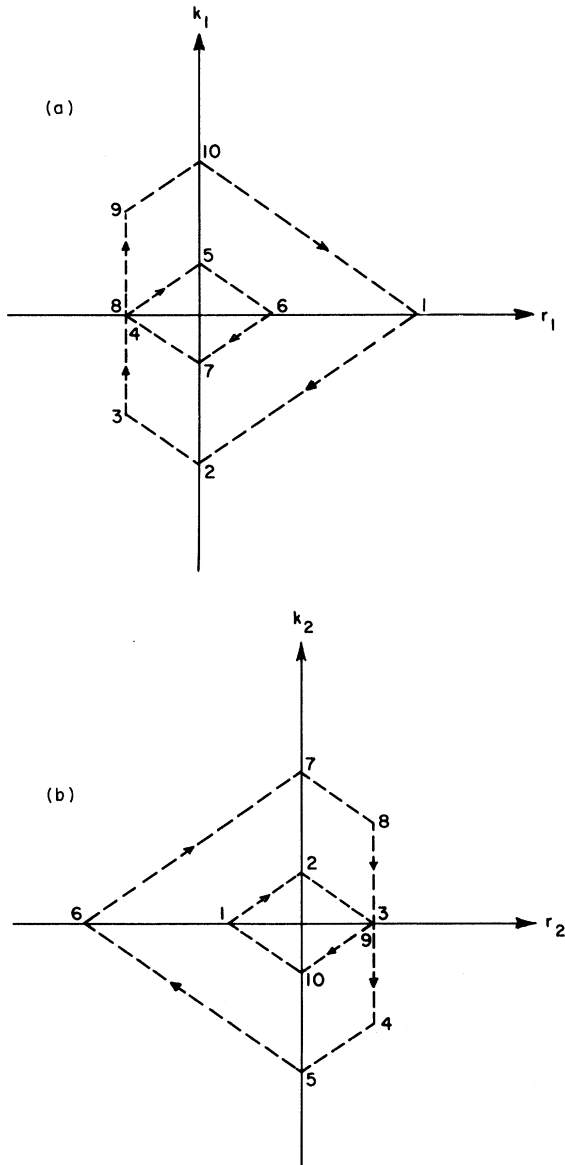

FIG. 10. (a) Phase-space orbit of one-fold system projected on the  $(k_1, r_1)$  plane; (b) projection on the  $(k_2, r_2)$  plane. Numbers label sequential configurations in  $\tau$ .

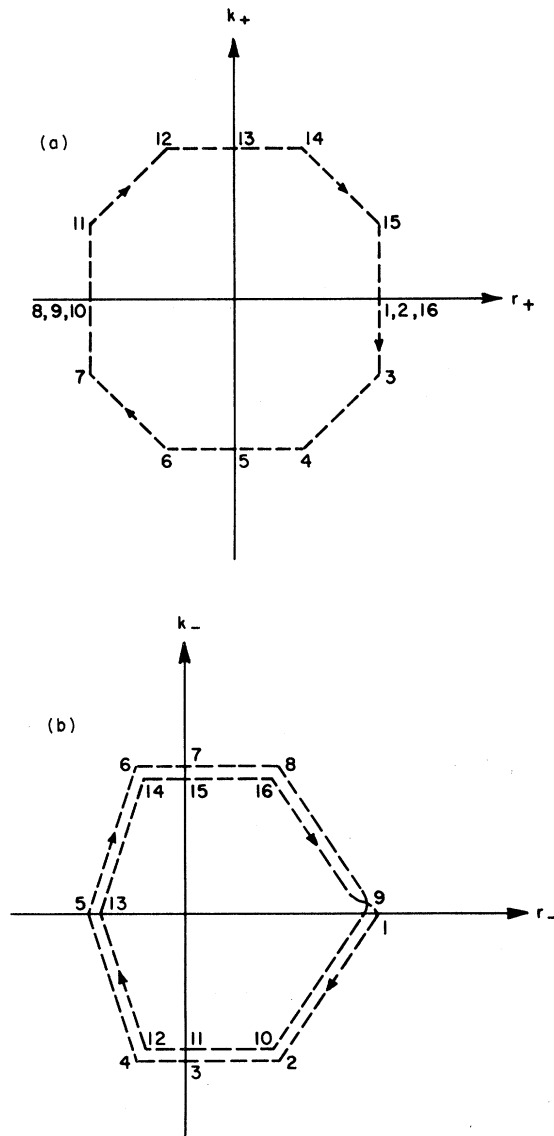

FIG. 11. (a) Phase-space orbit of one-fold system projected on the  $(k_+, r_+)$  plane; (b) projection on the  $(k_-, r_-)$  plane. Coincident paths are displaced for clarity; numbers label sequential configurations in  $\tau$ .

in terms of  $J_{\pm}$ , with the result

$$M^2/\gamma = m^2/\gamma = J_+ + J_- = J_1 + J_2. \tag{5.14}$$

$J_+$  and  $J_-$  are clearly interpretable as normal modes. We see that when

$$c = \frac{1}{2} \pi \tag{5.15a}$$

then

$$J_+ = 0, \quad J_- = m^2/\gamma. \tag{5.15b}$$

The motion consists of the center point oscillating in opposition to the two ends, which remain coincident throughout the motion. This is a completely folded string. When

$$c = 0 \text{ or } c = \pi \tag{5.16a}$$

then

$$J_+ = m^2/\gamma, \quad J_- = 0. \tag{5.16b}$$

In this case the end points move exactly as in the no-fold problem of Sec. III; the "center" point attaches itself alternately to one end point or the other, always remaining on the right side of the string (or always on the left side). In this case there are no folds in the string. We plot these normal-mode motions in Fig. 13.

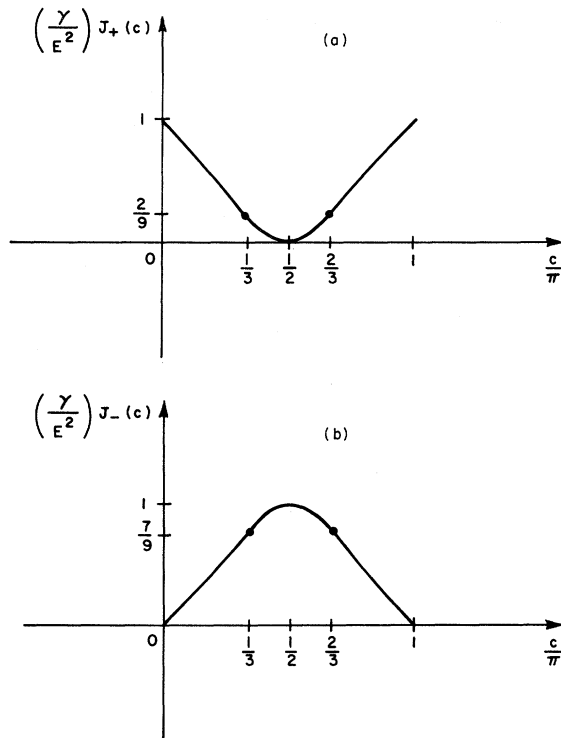

FIG. 12. (a) The action variable  $J_+$  as a function of initial condition  $c$ ; (b) the action variable  $J_-$ .

B.  $N$ -fold modes

We have shown in our explicit analysis of the no-fold mode that

$$H(P=0) = M = (\gamma J)^{1/2}, \tag{5.17}$$

while for the one-fold mode

$$H(P=0) = M = [\gamma(J_+ + J_-)]^{1/2} = [\gamma(J_1 + J_2)]^{1/2}. \tag{5.18}$$

$J_+$  was identifiable with a normal mode indistinguishable from the no-fold motion described by  $J$ ;  $J_-$  corresponded to a double cycle of the completely symmetric folded mode of the one-fold motion, as can be seen from Fig. 13. It is clearly of interest to know whether similar expressions hold for arbitrary  $P$  and for an arbitrary number of folds. We will now show in fact that for  $N$  folds, the Hamiltonian can be written in terms of  $P^2$  and a sum of appropriate action variables alone.

We begin by defining the local action variable

$$J(\sigma) = \oint_{\text{one period}} \mathcal{P}(\tau, \sigma) dx(\tau, \sigma) = \int_{-\pi}^{\pi} d\tau \mathcal{P}(\tau, \sigma) x_{\tau}(\tau, \sigma). \tag{5.19}$$

In the timelike orthonormal gauge of Sec. IV,  $\mathcal{P} = \gamma x_{\tau}$  and  $x(\tau, \sigma)$  is given by Eq. (4.10). Then we may consider the direct sum of all the action variables, which we write as

$$\int_0^{\pi} d\sigma J(\sigma) = \frac{1}{2\gamma} \int_{-\pi}^{\pi} d\tau \int_{-\pi}^{\pi} d\sigma \mathcal{P}^2(\tau, \sigma) = \frac{E^2}{4\pi^2\gamma} \int_{-\pi}^{\pi} d\tau \int_{-\pi}^{\pi} d\sigma [1 + f'(\tau + \sigma)f'(\tau - \sigma)]. \tag{5.20}$$

In the last line we have used Eqs. (4.11) and (4.12).

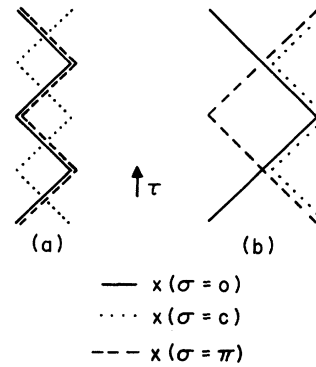

FIG. 13. (a)  $x$ -space motion for  $c = \pi/2$ , a pure  $J_-$  normal mode; (b)  $x$ -space motion for  $c = \pi$ , a pure  $J_+$  normal mode. Note that in case (a) the system returns to its initial configuration in half the time required by case (b).

Changing variables from  $(\tau, \sigma)$  to  $(\tau + \sigma, \tau - \sigma)$  and using Eq. (4.13), we find

$$\int_0^\pi d\sigma J(\sigma) = \frac{E^2 + P^2}{\gamma}.$$

We now subtract the contribution of the translation mode action variable [see, e.g., Eqs. (3.18)–(3.19) or (5.4)–(5.6)]

$$J_{PR} = \oint P dR = 2P^2/\gamma,$$

obtaining

$$M^2 = E^2 - P^2 = \gamma \left[ \int_0^\pi d\sigma J(\sigma) - J_{PR} \right]. \quad (5.21)$$

This argument extends trivially to  $D$  dimensions, with the result

$$M^2 = E^2 - \vec{P}^2 = \gamma \sum_{i=1}^{D-1} \int_0^\pi d\sigma J_i(\sigma) - 2\vec{P}^2. \quad (5.22)$$

In two spacetime dimensions we may revert to the  $x_\sigma$ -uniform gauge and write Eq. (5.21) as

$$M^2 = \gamma \sum_{n=1}^\infty J_n, \quad (5.23)$$

where

$$J_n = \oint_{\text{complete cycle}} k_n dr_n \quad (5.24)$$

and  $(P, R; k_n, r_n)$  comprise a complete set of canonically conjugate pairs of variables.

We saw in the one-fold problem that a particular choice of  $(k_n, r_n)$  makes one of the  $J_n$ 's ( $J_+$ ) a pure no-fold variable, the other ( $J_-$ ) a pure single-fold variable. In addition, the no-fold variables ( $k_+, r_+$ ) went through one cycle while the single-fold variables ( $k_-, r_-$ ) went through two complete cycles, as seen in Figs. 11(a) and 11(b). It is easy to convince oneself that the completely symmetric  $N$ -fold string, with orthonormal-gauge initial  $\sigma$  conditions

$$c_n = \frac{n\pi}{N+1}, \quad n = 1, 2, \dots, N \quad (5.25)$$

undergoes  $N+1$  identical cycles while the no-fold variables finish one complete cycle. The appropriate Bohr-Sommerfeld quantization applies to the variables

$$\tilde{J}_n = \frac{1}{n} J_n = \oint_{\text{single cycle}} k_n dr_n, \quad (5.26)$$

where the integral in Eq. (5.26) is over one cycle in the  $(k_n, r_n)$  subspace instead of one cycle in the full phase space. We thus take

$$M^2 = \gamma \sum_{n=1}^\infty n \tilde{J}_n, \quad (5.27)$$

where  $\tilde{J}_1$  represents a pure no-fold string,  $\tilde{J}_2$  is associated with a string having one fold in the

middle,  $\tilde{J}_3$  with two folds, etc. The Bohr-Sommerfeld quantization rule is

$$\tilde{J}_n = 2\pi\hbar(l_n + \text{const}), \quad l_n = 0, 1, 2, \dots \quad (5.28)$$

The Hamiltonian describing the motion for any number of folds, given appropriate initial conditions, is then

$$H = \left( P^2 + \gamma \sum_{n=1}^\infty n \tilde{J}_n \right)^{1/2}. \quad (5.29)$$

Defining  $\theta_n(\tau)$  to be the canonical conjugate to  $\tilde{J}_n(\tau)$ , we find from Hamilton's equations

$$\omega_n \equiv \dot{\theta}_n = \frac{\partial H}{\partial \tilde{J}_n} = \frac{n\gamma}{2H} = \text{constant}. \quad (5.30)$$

Thus

$$\theta_n(\tau) = \theta_n(0) + \frac{n\gamma\tau}{2H}, \quad (5.31)$$

where  $\theta_n(0)$  is a constant of motion. Since  $H$  is independent of  $\theta_n(\tau)$ , each of the  $\tilde{J}_n$ 's is also a constant of motion. Thus we have been able to express the  $N$ -fold string problem as a completely integrable Hamiltonian system. Equation (5.29) for the two-dimensional string parallels exactly the Faddeev-Takhtajan Hamiltonian<sup>6</sup> for the classical sine-Gordon equation; both give the complete solution to their respective nonlinear classical systems.

## VI. TOWARD CANONICAL QUANTIZATION

Although we have completely solved the classical longitudinal string, the quantum theory does not follow trivially from the diagonalized Hamiltonian (5.29). Even the no-fold Schrödinger equation (3.26) could not be solved for the exact quantum spectrum. Motivated by the desire to have local commutation relations among  $\mathcal{P}^\mu(\tau, \sigma)$  and  $x^\mu(\tau, \sigma)$ , we devote this section to a timelike orthonormal-gauge treatment of the string constraints. The constrained oscillators in two spacetime dimensions should then determine the canonical properties of the longitudinal string motions.

The first step is to separate the over-all center-of-mass variables of the system from those describing the intrinsic motion. In the lightlike orthonormal gauge

$$\begin{aligned} x^+ &= P^+ \tau / \pi\gamma, \\ \mathcal{P}^+ &= P^+ / \pi, \end{aligned} \quad (6.1)$$

the standard over-all coordinate variables

$$Q^\mu = M^{\mu+} / P^+ \quad (6.2)$$

commuted with one another. Unfortunately, as we saw at the end of Sec. III, treating longitudinal oscillations in the lightlike gauge is exceedingly

difficult. In the timelike gauge

$$\begin{aligned} x^0 &= P^0 \tau / \pi \gamma, \\ \mathcal{P}^0 &= P^0 / \pi, \end{aligned} \quad (6.3)$$

the coordinates are

$$Q^\mu = M^{\mu 0} / P^0. \quad (6.4)$$

These  $\vec{Q}$ 's do not commute (except in two dimensions), and hence are unsuitable center-of-mass coordinates; nevertheless, this system can be mapped directly into the lightlike-gauge variables using DDF variables,<sup>10</sup> with the result that the *transverse sectors* of the string in the two gauges are equivalent.<sup>11</sup>

Here we investigate a timelike gauge condition used by Rohrlich<sup>7</sup> which produces appropriate commuting (Newton-Wigner) coordinates for the string's center of mass. The fully constrained Dirac bracket system does not seem to imply the simple quantum spectrum postulated by Rohrlich. By going to two spacetime dimensions, we are able to exhibit clearly the complicated nature of the longitudinal modes appearing in the classical system.

#### A. Newton-Wigner coordinates

In order to illuminate the canonical properties of the orthonormal-gauge Fourier coefficients (4.4), we wish to separate out the Newton-Wigner coordinates  $Q^\mu$  of the center of mass. A general expression for  $Q^\mu$  is

$$Q^\mu = \frac{M^{\mu 0}}{P^0 + P} - \frac{M^{\mu\nu} P_\nu}{P(P^0 + P)} + \frac{P^\mu M^{0\nu} P_\nu}{PP^0(P^0 + P)}, \quad (6.5)$$

where

$$P = (-P^2)^{1/2} = [(P^0)^2 - \vec{P}^2]^{1/2} \quad (6.6)$$

and  $Q^0 \equiv 0$  defines  $Q^\mu$  as a timelike-gauge variable. Using the canonical Poisson-bracket algebra of the Poincaré group,

$$\{M^{\mu\nu}, P^\alpha\} = g^{\mu\alpha} P^\nu - g^{\nu\alpha} P^\mu, \quad (6.7)$$

$$\begin{aligned} \{M^{\mu\nu}, M^{\alpha\beta}\} &= g^{\mu\alpha} M^{\nu\beta} - g^{\nu\alpha} M^{\mu\beta} + g^{\mu\beta} M^{\alpha\nu} \\ &\quad - g^{\nu\beta} M^{\alpha\mu}, \end{aligned} \quad (6.8)$$

we find

$$\begin{aligned} \{Q^\mu, Q^\nu\} &= 0, \\ \{Q^\mu, P^\alpha\} &= g^{\mu\alpha} - g^{0\alpha} \frac{P^\mu}{P^0}. \end{aligned} \quad (6.9)$$

$P^0$  is seen to act as the Hamiltonian, since

$$\{\vec{Q}, P^0\} = \vec{P} / P^0 \quad (6.10)$$

is the velocity of the center of mass. If  $M^{\mu\nu}$  has

the form

$$M^{\mu\nu} = Q^\mu P^\nu - Q^\nu P^\mu + S^{\mu\nu}, \quad (6.11)$$

then the definition (6.5) of  $Q^\mu$  is an identity if

$$S^{\mu\nu} P_\nu - P S^{\mu 0} = 0. \quad (6.12)$$

Taking  $J^i = \frac{1}{2} \epsilon^{ijk} S^{jk}$  as the independent components of  $S^{\mu\nu}$ , we see that the constraint (6.12) implies the usual Wigner representation of the classical boost:

$$M^{0i} = (\vec{N})_i = \left( -P^0 \vec{Q} + \frac{\vec{J} \times \vec{P}}{P^0 + P} \right)_i, \quad (6.13)$$

For massless states this formalism is modified to replace  $\vec{Q}$  and  $\vec{J}$  by appropriate massless-particle variables.<sup>12</sup>

In any orthonormal gauge the spin matrix  $S^{\mu\nu}$  for the string model takes the form

$$S^{\mu\nu} = \frac{i}{\pi\gamma} \sum_{n \neq 0} \frac{1}{n} \alpha_n^\mu \alpha_{-n}^\nu. \quad (6.14)$$

Thus Eq. (6.12) implies that the constraints on the Fourier components (4.4) necessary to give Newton-Wigner  $\vec{q}$ 's are

$$g_n \equiv \alpha_n^0 (P^0 + P) - \vec{\alpha}_n \cdot \vec{P} = 0 \quad (6.15a)$$

along with

$$q^0 = 0. \quad (6.15b)$$

The analogs of the gauge conditions (6.1) and (6.3) on the canonical fields are

$$\begin{aligned} x^0(\tau, \sigma)(P^0 + P) - \vec{x}(\tau, \sigma) \cdot \vec{P} - \frac{M^{0\mu} P_\mu}{P^0} &= \frac{\tau}{\pi\gamma} P(P^0 + P), \\ \mathcal{P}^0(\tau, \sigma)(P^0 + P) - \vec{P} \cdot \vec{\mathcal{P}}(\tau, \sigma) &= \frac{1}{\pi} P(P^0 + P). \end{aligned} \quad (6.16)$$

#### B. Dirac brackets

The canonical Poisson brackets (4.7) are not compatible with the constraints (4.5) and (6.15). However, one may define modified brackets—the Dirac brackets<sup>13</sup>—which are manifestly consistent with the constraints. In the Appendix we define and calculate the Dirac brackets for the Fourier components of the string in the Newton-Wigner gauge; we also present an alternative technique, using gauge-invariant variables, which yields equivalent results.

The computations in the Appendix give the following formulas for the Dirac brackets, distinguished hereafter by an asterisk:

$$\{q^\mu, q^\nu\}^* = 0, \quad (6.17)$$

$$\{q^\mu, P^\alpha\}^* = g^{\mu\alpha} - g^{\alpha\mu} P^\mu / P^0,$$

$$\begin{aligned} \{\alpha_m^i, \alpha_n^j\}^* = & -i\pi\gamma\delta^{ij}m\delta_{m,-n} + mn(P^j\alpha_{n+m}^i T_n - P^i\alpha_{n+m}^j T_m)(\pi\gamma)^2 + mn\alpha_n^j \left[ P^i(U_m - V_m) - \sum_{l \neq 0, m} V_l \alpha_{m-l}^i \right] (\pi\gamma)^2 \\ & - mn\alpha_m^i \left[ P^j(U_n - V_n) - \sum_{l \neq 0, n} V_l \alpha_{n-l}^j \right] (\pi\gamma)^2 - 2mn(\pi\gamma)^2 \sum_{l \neq 0, m, -n} T_l \alpha_{m-l}^i \alpha_{n+l}^j, \end{aligned} \quad (6.18)$$

$$\{q^i, \alpha_n^j\}^* = -\frac{n\alpha_n^j}{M^2(H+M)} \sum_{l \neq 0} \frac{1}{l} \alpha_l^i \alpha_{-l}^0 + \frac{n}{M(H+M)} \sum_{l \neq 0, -n} \frac{1}{l} \alpha_{-l}^i \alpha_{n+l}^j - \frac{nP^i}{HM(H+M)} \sum_{l \neq 0, -n} \frac{1}{l} \alpha_{-l}^0 \alpha_{n+l}^j. \quad (6.19)$$

Here  $T_n, U_n, V_n$  are defined in the Appendix. Since the constraints (4.5) are now strongly valid, we are free to define

$$M^2 = -P^2 = \sum_{m \neq 0} \alpha_m \cdot \alpha_{-m} \quad (6.20)$$

even though  $\alpha_n^0$  contains implicit  $M^2$  dependence; similarly, we may now take

$$H \equiv P^0 = (\tilde{P}^2 + M^2)^{1/2} \quad (6.21)$$

as a dependent variable. Equations (6.17) indicate that canonical quantization is straightforward for  $\tilde{q}$  and  $\tilde{P}$ . Unfortunately the Dirac brackets (6.18) and (6.19) are so complicated that canonical quantization is decidedly nontrivial.

### C. Two-dimensional system

In two spacetime dimensions the only simple solution of the constraint equations (4.5) is

$$\begin{aligned} \alpha_n^\mu &= 0, \\ P^\mu P_\mu &= 0, \end{aligned} \quad (6.22)$$

so  $x^\mu$  has only translational degrees of freedom,

$$\begin{aligned} x^0 &= \frac{|P|\tau}{\pi\gamma}, \\ x^1 &= q + \frac{P\tau}{\pi\gamma}. \end{aligned} \quad (6.23)$$

The Newton-Wigner coordinate (6.5) becomes simply

$$Q = \frac{M^{10}}{P^0}. \quad (6.24)$$

However, the Dirac brackets (6.18) evaluated in two dimensions indicate that a highly nontrivial Hamiltonian system still exists if  $\alpha_n^\mu = 0$  is excluded. These brackets presumably give all the available information about the classical Hamiltonian dynamics of the longitudinal modes. We exhibit the brackets of  $\alpha_n^1 \equiv \alpha_n$  in the rest frame

$P = 0, H = M$ , for simplicity:

$$\begin{aligned} \{P, q\}^* &= -1, \\ \{q, H\}^* &= P/H = 0, \\ \{H, \alpha_n\}^* &= \frac{in\alpha_n}{M}, \end{aligned} \quad (6.25)$$

$$\{q, \alpha_n\}^* = -\frac{n}{2M^2} \sum_{l \neq 0, n} \frac{1}{l} \alpha_l \alpha_{n-l},$$

$$\{P, \alpha_n\}^* = 0,$$

$$\{\alpha_m, \alpha_n\}^* = -i \left( \pi\gamma m \delta_{m,-n} + \frac{mn}{M^2} \sum_{l \neq 0, m, -n} \frac{1}{l} \alpha_{m-l} \alpha_{n+l} \right).$$

Even in two dimensions we see that canonical quantization of the longitudinal modes will be difficult.

### VII. CONCLUSION

We have investigated the massless limit of a model for the massive Nambu string and have found that we recover longitudinal modes of oscillation excluded from the GGRT treatment. These oscillations are kink-like, not linearly superimposable, and are identifiable with those proposed by Patrascioiu.

The model was examined in detail in two spacetime dimensions and the Hamiltonian expressed in terms of normal-mode action variables alone. The resulting theory was a completely integrable classical Hamiltonian system. The Bohr-Sommerfeld approximation to the quantum mechanics gave a linear, integer-spaced, mass-squared spectrum.

Finally, we separated the simultaneously measurable Newton-Wigner coordinates of the string center of mass and examined the Dirac brackets of the oscillators occurring in the fully constrained,





$$C^{-1}_{\alpha\beta} = \begin{matrix} & L_{n>0} & L_0 & L_{n<0} & & g_{n>0} & q_0 & g_{n<0} \\ L_{m>0} & & V_{-2} & 2T_{-2} & & & & T_{-2} \\ & & V_{-1} & 2T_{-1} & & & & T_{-1} \\ L_0 & -V_{-2} - V_{-1} & 0 & -V_1 - V_2 \dots & \dots & -U_{-2} - U_{-1} & 1/H & -U_1 - U_2 \\ & 2T_1 & V_1 & & & & T_1 & \\ L_{m<0} & 2T_2 & V_2 & & & & T_2 & \\ & & \vdots & & & & & \vdots \\ & & \vdots & & & & & \vdots \\ & & U_{-2} & T_{-2} & & & & \\ g_{m>0} & & U_{-1} & T_{-1} & & & & \\ q_0 & & -1/H & & & & \approx 0 & \\ & T_1 & U_1 & & & & & \\ g_{m<0} & T_2 & U_2 & & & & & \end{matrix} \quad (A6)$$

Using  $C^{-1}_{\alpha\beta}$  and Eq. (A2) we obtain for the Dirac brackets the formula

$$\begin{aligned} \{A, B\}^* = & \{A, B\} - \{A, L_n\} V_{-n} \{L_0, B\} + \{A, L_0\} V_n \{L_{-n}, B\} - \{A, L_{-n}\} 2T_n \{L_n, B\} \\ & - \{A, L_{-n}\} T_n \{g_n, B\} - \{A, L_0\} \frac{1}{H} \{q^0, B\} + \{A, L_0\} U_n \{g_{-n}, B\} \\ & + \{A, q^0\} \frac{1}{H} \{L_0, B\} - \{A, g_{-n}\} U_n \{L_0, B\} - \{A, g_{-n}\} T_n \{L_n, B\}. \end{aligned} \quad (A7)$$

Here the implicit sums over  $n$  exclude  $n = 0$ . Equations (6.17), (6.18), and (6.19) in the main text follow directly from Eq. (A7).

### 2. Gauge-invariant oscillators

A simple extension of the concepts introduced in Ref. 11 allows us to construct gauge-invariant classical oscillators obeying the Newton-Wigner gauge constraints (6.15). The Newton-Wigner coordinates  $Q^\mu$  given by Eq. (6.5) are already gauge-invariant, and satisfy  $Q^0 = 0$ . The analogs of the DDF variables<sup>10</sup> are given by

$$A_n^\mu = \frac{1}{2} \gamma \int_{-\pi}^{\pi} d\theta \frac{dX^\mu(\theta)}{d\theta} \exp \left\{ in\pi\gamma \left[ \frac{X^0(\theta)(H+M) - \vec{X}(\theta) \cdot \vec{P} - M^{\alpha\mu} P_\mu / H}{M(H+M)} \right] \right\}, \quad (A8)$$

where in any orthonormal gauge  $X^\mu(\theta)$  may be expressed in the form

$$X^\mu(\theta) = q^\mu + \frac{P^\mu \theta}{\pi\gamma} + \frac{i}{\pi\gamma} \sum_{n \neq 0} \frac{1}{n} \alpha_n^\mu e^{-in\theta}. \quad (A9)$$

This expression and Eq. (4.7) define the canonical Poisson brackets of  $X^\mu(\theta)$ , and hence the canonical properties of  $A_n^\mu$  are determined. Note also that

$$\frac{1}{2} \gamma [X^\mu(\pi) - X^\mu(-\pi)] = P^\mu. \quad (A10)$$

All of the arguments in Ref. 11 may now be imitated to analyze the properties of  $A_n^\mu$ . The first result is that  $A_n^\mu$  is invariant under the action of the Virasoro constraints (4.5), which gen-

erate the gauge transformations. In addition,  $A_n^\mu$  itself obeys the Newton-Wigner constraints (6.15a),

$$A_n^0(H+M) - \vec{A}_n \cdot \vec{P} = \delta_{n,0} M(H+M), \quad (A11)$$

where  $A_n^\mu$  with  $n = 0$  is just the momentum:

$$A_0^\mu = P^\mu. \quad (A12)$$

The canonical brackets of  $A_n^\mu$  and  $Q^\mu$  among themselves are identical in form to the Dirac brackets (6.18) and (6.19) of  $\alpha_n^\mu$ ,  $q^\mu$ , and  $P^\mu$ . Unfortunately no explicit solution of the Virasoro constraints obeyed by  $A_n^\mu$  is known, so that the quantum analysis of the closure of the Lorentz algebra cannot be carried out.

\*Research supported in part by the U. S. Energy Research and Development Administration.

†Research supported in part by the U. S. Energy Research and Development Administration under Contract No. AT(11-1) 3075.

‡Research supported in part by the National Science Foundation under Grant No. PHY 75-18444.

<sup>1</sup>Y. Nambu, lectures at Copenhagen Summer Symposium, 1970 (unpublished).

<sup>2</sup>P. Goddard, J. Goldstone, C. Rebbi, and C. B. Thorn, Nucl. Phys. B56, 109 (1973).

<sup>3</sup>S. Mandelstam, Nucl. Phys. B64, 205 (1973).

<sup>4</sup>A. Patrascioiu, Nucl. Phys. B81, 525 (1974).

<sup>5</sup>A. Chodos and C. B. Thorn, Nucl. Phys. B72, 509 (1974).

<sup>6</sup>L. D. Faddeev and L. A. Takhtajan, Teor. Mat. Fiz. 21, 160 (1974) [Theor. Math. Phys. 21, 1046 (1974)].

<sup>7</sup>F. Rohrlach, Phys. Rev. Lett. 34, 842 (1975).

<sup>8</sup>Other choices of gauge lead also to Eq. (3.10), e.g.,  $x(\tau, \sigma) = \frac{1}{2} \cos \sigma [x(\tau, 0) - x(\tau, \pi)] + \frac{1}{2} [x(\tau, 0) + x(\tau, \pi)]$ . However, the  $x_\sigma$ -uniform gauge is particularly convenient.

<sup>9</sup>This equation has been derived in a different context by G. 't Hooft, Nucl. Phys. B75, 461 (1975). We would like to thank C. Rebbi for informing us of the work of 't Hooft.

<sup>10</sup>E. Del Giudice, P. Di Vecchia, and S. Fubini, Ann. Phys. (N.Y.) 70, 378 (1972).

<sup>11</sup>P. Goddard, A. J. Hanson, and G. Ponzano, Nucl. Phys. B89, 76 (1975).

<sup>12</sup>See, e.g., J. Schwinger, *Particles, Sources, and Fields* (Addison-Wesley, Reading, Mass., 1970), Vol. I.

<sup>13</sup>P. A. M. Dirac, Proc. R. Soc. London A246, 333 (1958); A. J. Hanson, T. Regge, and C. Teitelboim, *Constrained Hamiltonian Systems* (Accademia Nazionale dei Lincei, Rome, 1975, to be published).