







Effect of rotation in the γ -ray emission from 60 meV polarized neutron-induced fission of the ^{235}U isotope

D. Berikov ^{1,2,*}, G. Ahmadov ^{1,3,4,†}, Yu. Kopatch ^{1,5}, A. Gagarski,⁶ V. Novitsky,^{1,5} H. Deng,⁷ G. Danilyan,^{1,5} S. Masalovich ⁸, Z. Salhi,⁹ E. Babcock ⁹, J. Klenke,⁸ and V. Hutanu ⁷

¹Frank Laboratory of Neutron Physics, Joint Institute for Nuclear Research, 141980 Dubna, Russia

²Institute of Nuclear Physics of the National Nuclear Center of Kazakhstan, 050032 Almaty, Kazakhstan

³Azerbaijan National Academy of Sciences - CSSR and IRP, AZ1143 Baku, Azerbaijan

⁴Department of Nuclear Physics, National Nuclear Research Center, AZ1073 Baku, Azerbaijan

⁵Institute for Theoretical and Experimental Physics of National Research Centre “Kurchatov Institute”, 117218 Moscow, Russia

⁶Petersburg Nuclear Physics Institute of National Research Centre “Kurchatov Institute”, 188300 Leningradskaya Oblast, Russia

⁷Institute of Crystallography, RWTH Aachen and Jülich Centre for Neutron

Science at Heinz Maier-Leibnitz Zentrum (MLZ), 85748 Garching, Germany

⁸Heinz Maier-Leibnitz Zentrum (MLZ), Technical University of Munich, 85748 Garching, Germany

⁹Jülich Centre for Neutron Science (JCNS) at the Heinz Maier-Leibnitz Zentrum (MLZ), 85748 Garching, Germany



(Received 15 April 2021; accepted 20 July 2021; published 9 August 2021)

In the paper we present the results obtained for the effect of rotation (ROT) in the angular distribution of prompt γ rays from the fission of ^{235}U induced by monochromatic polarized “warm” neutrons ($E_n = 60$ meV). The polarization vector direction is determined at the target position in order to correctly determine the sign of the measured effect. The asymmetry parameter was found to be equal to $R_\gamma = -(17.3 \pm 2.8) \times 10^{-5}$. Moreover, the rotation angle of the fission axis was determined to be equal to $0.069^\circ \pm 0.008^\circ$ taking into account the fit results of the angular distribution of the prompt fission γ rays. The obtained value and sign of the ROT effect are consistent with the results of the ROT effect obtained for cold neutrons. We describe the experiment, methodology of sign determination, and implications of the results.

DOI: [10.1103/PhysRevC.104.024607](https://doi.org/10.1103/PhysRevC.104.024607)

I. INTRODUCTION

Spin-angular correlations are a powerful tool for studying any characteristics associated with spins, allowing us to obtain new information about the mechanisms of reactions and decays [1]. Asymmetry in the angular distribution of light and heavy fission fragments is a source of information about the mechanism and dynamics of the fission process (induced by γ quanta, neutrons, charged particles) and about the statistical properties of compound states. In turn, the spin-angular correlations are also sensitive to the violations of fundamental symmetries.

The beginning of the studies of spin-angular correlations in nuclear fission was laid by the discovery in 1977 of the spatial parity violation effect in the fission of ^{239}Pu nuclei by polarized neutrons [2]. The effect consists in the fact that there is an asymmetry of the emission (scale 10^{-4}) of a light fragment along and against the direction of the spin of the fissile nucleus.

The T -odd correlations in the ternary fission of ^{233}U nuclei by polarized cold (s -wave) neutrons were first discovered by the authors of [3,4] in 1997. The search for

this correlation [so-called left-right asymmetry or time reversal invariance (TRI) effect] was carried out at the high-flux ILL reactor (Laue-Langevin Institute, Grenoble, France) by a collaboration, which included, in particular, Institute for Theoretical and Experimental Physics of National Research Centre (ITEP) (Moscow), Petersburg Nuclear Physics Institute of National Research Centre (PNPI) (Gatchina), Physics Institute of University of Tübingen (PI) (Tübingen), and Institute of Nuclear Physics of Darmstadt Technical University (IKP) (Darmstadt). The asymmetry of the number of α -particle–fission-fragment (FF) coincidences was measured experimentally for opposite directions of the incident neutron beam polarization,

$$D = \frac{N^+ - N^-}{N^+ + N^-} \quad (1)$$

where N^+ and N^- are the numbers of coincidences for the neutron spin being parallel and antiparallel to the vector product $[p_{FF} \times p_\alpha]$. As a result, it was found that the probability of emission of an α particle in ternary fission perpendicular to the plane formed by the neutron spin and the fragment momentum shows a pronounced asymmetry, equal to $D_{TRI} = -(2.35 \pm 0.05) \times 10^{-3}$. And for ^{235}U , from the same authors [5], an asymmetry is obtained that is smaller in absolute value than for ^{233}U and with the opposite sign, which is equal to $D_{TRI} = +(0.76 \pm 0.09) \times 10^{-3}$.

*daniyar.berikov@gmail.com

†ahmadovgadmir@gmail.com

As a part of further study of this asymmetry in the fission reaction of ^{235}U nucleus by cold polarized neutrons, it was discovered that, when reversing the polarization direction of the neutron beam, the angular distribution of the long-range α particles is shifted by a small angle ($2\Delta = 0.215^\circ \pm 0.005^\circ$) relative to the axis of fragment emission [6]. The offset direction is determined by the direction of polarization of the neutron beam. The authors explained the discovered effect within the framework of a semiclassical model [6]. According to the model, after the capture of a polarized neutron by an unpolarized nucleus, the resulting compound nucleus becomes partially polarized. Thus, the fissioning nucleus acquires an additional rotational component of the angular momentum, which is collinear with the spin of a polarized neutron causing the fission. After the rupture of the nucleus neck, this additional part of the rotational moment of the nucleus is transferred to the fission fragments, which are emitted with an additional tangential velocity component, directed perpendicular to the deformation axis of the fissile nucleus. Thus, the axis of the fission fragments emission at infinity will not coincide with the axis of deformation of the fissile nucleus at the moment of the neck rupture, but deviate from it by an angle δ_{FF} .

In the ternary fission, the trajectory of the α particle also rotates along with the fission axis (its motion is significantly affected by the electric field of the fragments). Since the speed of the α particle is noticeably higher than the speed of the fragments, the α particle does not have time to completely “track” the change in the direction of fragments emission relative to the initial axis of nucleus deformation. That is, the α particle rotates, but more slowly (by a smaller angle) than the fission axis. If the fissile nucleus is not polarized, then the effect of the nucleus rotation leads only to a certain “smearing” of the angular distribution of α particles relative to the axis of the fragments emission. In the case of a polarized nucleus, there is a preferred direction of rotation, which is defined by the polarization of the incident neutron. The sign of this rotation angle δ_{FF} will be opposite for opposite directions of polarization of the fissile nucleus. It is this phenomenon that is observed as the ROT effect (from “rotation”), i.e., rotation of the fission axis relative to the angular distribution of α particles in one or the other direction, depending on the fissioning nucleus polarization [see Fig. 1(a)].

Since the detection angle of the α particle is experimentally measured from the final direction of the light fragment motion, the angular shift, that was observed through the polarization of the compound nucleus, is the lag angle Δ of the α particle compared to the angle of the fission axis deflection. It is necessary to mention that in the experiment we can see directly only the double lag of ternary particle relative to the fission axis deflection: $2\Delta = 2(\theta - \theta') = 2(\delta_{FF} - \delta_\alpha)$ [see Figs. 1(a), 2(a)]. Trajectory calculations are required to determine the rotation angle of the fission axis δ_{FF} (the value of the ROT effect) in ternary fission [7].

In [8], the authors obtained the same sign for the coefficient of the ROT asymmetry in the angular distribution of α particles from ternary fission of ^{233}U nuclei induced by cold polarized neutrons as in the ternary fission of ^{235}U nuclei, but a smaller value, equal to $2\Delta = 0.021^\circ \pm 0.004^\circ$.

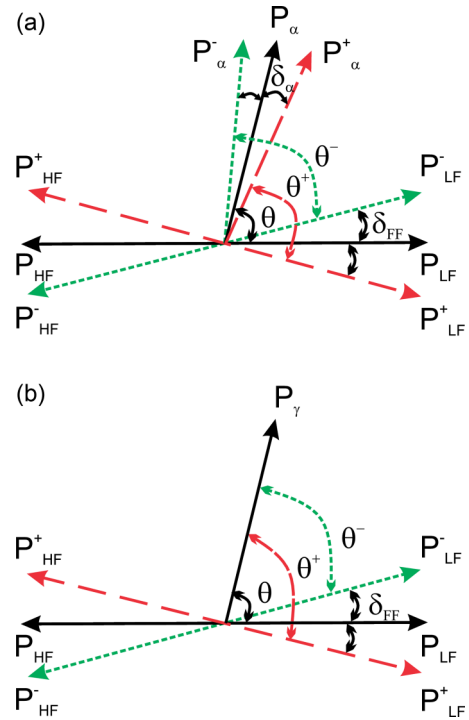

FIG. 1. The scheme of the formation of the shift in the angular distribution (a) of α particles from ternary fission and (b) of γ rays from fission fragments with respect to their measurement detection. P_{LF} , P_{HF} are the initial directions of fragments; P_α is the α -particle motion at the moment of scission. “+” and “-” label the final object directions for opposite directions of the neutron polarization.

According to the model, which was first proposed by Novitsky in [9] and described in detail in [10], the same behavior, but with opposite signs is expected for the ROT asymmetry in the angular distribution of prompt γ rays emitted in binary fission. Contrary to the α particles in ternary fission, emitted nearly perpendicular to the fission axis, the γ rays from fission fragments are emitted preferentially along the fission axis (see, e.g., [11–13]). The anisotropy of the γ -ray emission is much smaller than that of the α particles, and is caused by the alignment of the fission fragment spins along the fission axis [14]. Due to the angular momentum conservation law, the orientation of the fragment angular momenta (spins) remains the same with respect to the initial direction of the deformation axis of the fissioning nucleus, while the fission axis rotates by the angle δ_{FF} , as in ternary fission. Experimentally, this rotation can be observed as a shift in the angular distribution of the γ rays with respect to the fragment emission direction, depending on the neutron polarization [see Fig. 1(b)]. It is important to note that for γ quanta, in contrast to α particles, the determination of the rotation angle does not depend on complex trajectory calculations and is, in this sense, model independent.

Figure 2 shows the angular distributions of the α particles from ternary fission and of the gamma quanta from binary fission relative to the fission axis. From Figs. 2(a) and 2(b) one can see that, at the same angle of particle detection relative to the fission axis and for the same angle of rotation of the

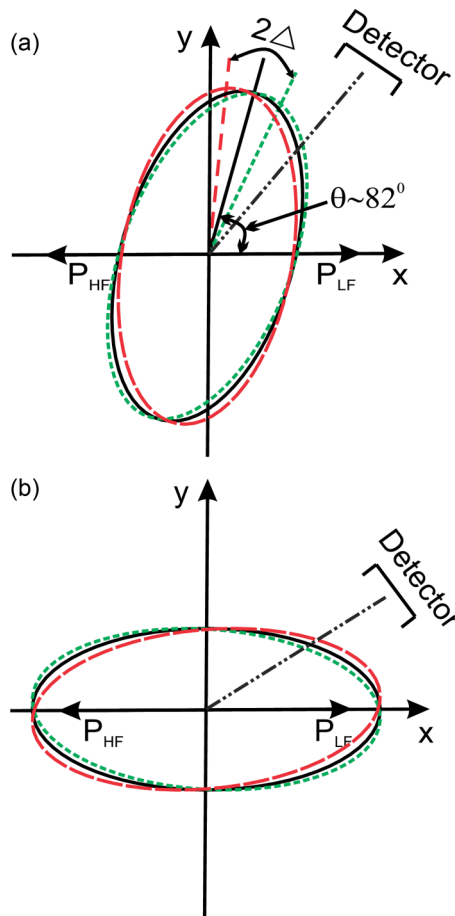

FIG. 2. Model of the ROT effect (a) for α particles and (b) for γ quanta. The solid line shows the angular distribution of the α particles from ternary fission and of γ quanta from binary fission relative to the fission axis. Dashed and dotted lines show this distribution for two polarization directions of the neutron beam.

fission axis δ_{FF} , the asymmetry coefficients for α particles from ternary fission and for γ quanta from binary fission calculated by formula (1) will be opposite (for α particles, the detector counts more at N^+ , and for γ rays at N^-). If the signs of the asymmetry were the same, this would mean that in ternary fission the nucleus rotates in one direction and in binary fission in the opposite. Such a situation is hard to imagine, since the nucleus does not know in advance how to decay.

An experiment to study the ROT effect in the angular distributions of prompt γ rays and neutrons was first carried out by the authors of [9,15]. The resulting sign of the ROT asymmetry at a certain angle turned out to be the same as for α particles of ternary fission. Later on, in [16] the sign of the effect was changed to the opposite and became consistent with the sign for α particles of ternary fission. Moreover, in [16] the ROT effect in the binary fission of ^{233}U and ^{235}U nuclei by polarized cold neutrons was measured simultaneously using the same setup. The target was composed as a “sandwich” made of ^{233}U and ^{235}U targets having the same parameters. As a result, it turned out that the ROT effect in the angular distributions of prompt γ rays in binary fission of ^{233}U has

TABLE I. The values of the ROT effect for prompt γ rays in binary fission for two different isotopes of uranium.

Target	ITEP group, ROT asymmetry at the angle 67.5° in 10^{-5} units		
	Reference [9]	Reference [15]	Reference [16]
^{235}U	$+12.1 \pm 4.9$	$+20.9 \pm 2.4$	-20 ± 1.8
^{233}U			$+6.8 \pm 2.4$

a different sign than the similar effect in the binary fission of ^{235}U , while the signs of ROT effect for the α particles for the same nuclei are identical. These discrepancies demonstrate that either the results of the measurements of either of the groups are not accurate enough or that the model of the ROT effect is not valid and there is another mechanism that is responsible for such behavior of the effect for different fissioning systems. The values of the ROT effect for prompt γ rays in binary fission, obtained by this group, are shown in Table I.

The dependence of the ROT effect on the energy of neutrons, causing the fission, was studied by our group (including measurement in the isolated resonance of ^{235}U) [17,18]. The current work is devoted to the investigation of the ROT effect in binary fission of ^{235}U induced by polarized, monochromatic neutrons with energy of 60 meV. Special attention was paid to determining the sign of the measured effect.

II. DESCRIPTION OF THE EXPERIMENT

The experimental measurements were carried out at the Heinz Meyer-Leibniz research neutron source (FRM II reactor) of the Munich Technical University in Garching (Germany). The experiment used a polarized neutron beam provided by the POLI diffractometer [19,20]. On POLI Cu-mosaic and Si-perfect crystal, variable double-focusing monochromators are employed to produce an intense monochromatic beam of required energy.

The neutrons were polarized using a ^3He neutron spin filter cell [21,22]. A second spin filter cell was also used as an analyzer for measuring beam polarization. Polarized ^3He gas for the polarizer and analyzer cells was created by two different optical pumping methods: SEOP (spin exchange optical pumping) and MEOP (metastable exchange optical pumping), respectively. The spin-exchange method is convenient and combines well with continuous beam work. An *in situ* ^3He polarizer was constructed for the TOPAS instrument which has very similar neutron beam dimensions and energy to the POLI instrument [23]. This *in situ* polarizer system was available and therefore installed on the POLI instrument for this experiment. The degree of neutron beam polarization was close to 100% and was calibrated to 99.2%, which remained constant during the experiment with a highly stable neutron transmission of 22% for the 60 meV neutrons used, corresponding to an 81% ^3He nuclear polarization. Figure 3 shows a general view of the SEOP polarizer.

The analyzer cell was polarized in an external laboratory using the MEOP method. Then, the polarized cell was

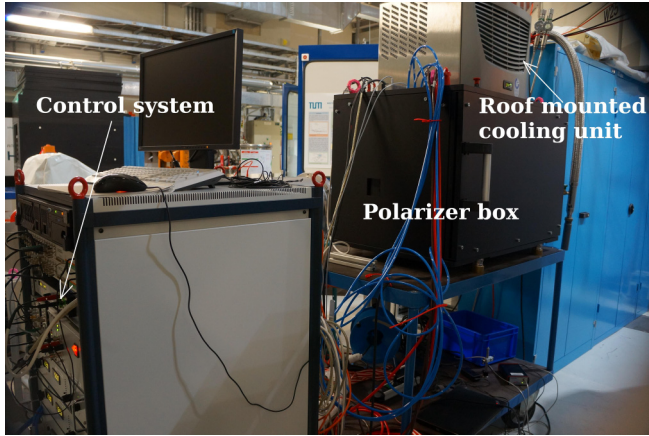

FIG. 3. SEOP polarizer with a roof mounted cooling unit and the control system.

transferred to the beam. To preserve polarization in the absence of optical pumping, the analyzer cell was placed in special magnetic housing with a highly homogeneous constant magnetic field [24]. The polarization of ^3He in the cell exponentially decreased with the time constant of about 65 h (due to relaxation), therefore analyzer cell was replaced every 48 h.

To transport a polarized neutron beam, a specially designed spin control system was used, consisting of several μ -metal shielded magnetic coils, which also made it possible to rotate the spin by 180° (flip) in a given position every 1.3 s [25].

The studied target was uranium oxide-protioxide $^{235}\text{U}_3\text{O}_8$ (99.99 %), deposited on both sides of a $\approx 30\ \mu\text{m}$ thick aluminum backing with a size of $50 \times 110\ \text{mm}^2$. The size of the uranium layer was $40 \times 100\ \text{mm}^2$ and the thickness of each uranium layer was about $1\ \text{mg}/\text{cm}^2$. The total amount of fissile material in the experiment was about 82 mg. The target was located with its long side along the direction of the incident beam of polarized neutrons.

The fission events were recorded by two fragment detectors—low-pressure position sensitive multiwire proportional counters (LPMWPC)—placed parallel to the target on

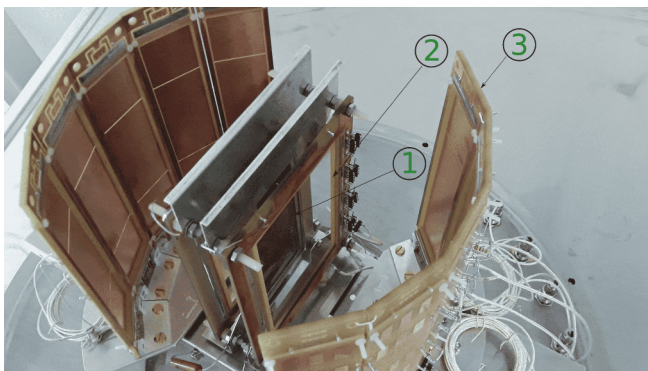

FIG. 4. Picture of the low-pressure position sensitive multiwire proportional counters. 1: fissile target; 2: start detector; 3: segmented stop detector.

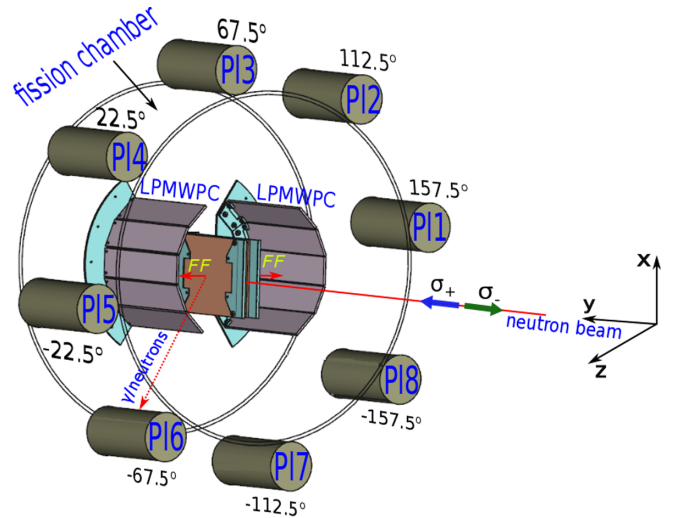

FIG. 5. The experimental layout for measuring the ROT effect in binary fission of ^{235}U induced by polarized, “warm,” monochromatic neutrons.

both sides (see Fig. 4). During the measurement the total number of recorded fission events was 2.8×10^7 .

The studied target and two fragment detectors were enclosed in a stainless steel vacuum-proof fission chamber filled with tetrafluoromethane gas (CF_4) at a pressure of about 10 mbar. In order to avoid neutron depolarization the entrance/exit windows of the chamber are made of Al alloy. For precise positioning of the target in the beam, the whole chamber is placed on a remotely controlled motorized rotation and translation stages. Prompt fission γ -ray detectors are located outside the fission chamber. Each of these detectors is a plastic scintillator. Eight cylindrical plastic scintillators with a diameter of 70 mm and a length of 120 mm, optically connected to a photomultiplier tube, wrapped in an antimagnetic screen, and placed in a sealed steel case, were inserted in a holder at a distance of about 30 cm from the target center.

The total time allocated for the experiment at the POLI instrument was 37 days.

III. EXPERIMENTAL METHOD

The sign of the ROT effect depends on the rotation direction of the nucleus, which is determined by the spin value of the compound nucleus. When a nucleus with the spin of the ground state I captures an s wave ($L = 0$) thermal or low energy neutron, the states of the compound nucleus with spins $J = I + 1/2$ and $J = I - 1/2$ are formed. For the $I + 1/2$ state the direction of nucleus polarization coincides with the direction of neutron beam polarization, while for the $I - 1/2$ state it is the opposite.

In the experiment, longitudinally polarized neutrons were used (the neutron spin is directed forward and backward along the particle momentum). Let the y axis be directed along the neutron beam (see Fig. 5).

The target is located at the origin. Fragments emitted along and against the z axis are recorded by LPMWPC. The LPMWPC is a system consisting of start and stop detectors.

The start detectors were placed at a distance of 1 cm, and stop detectors at a distance of 11 cm from the target. Each stop counter consists of five independent segments at the angles of 0° , $\pm 22.5^\circ$, $\pm 45^\circ$ on the left and $\pm 135^\circ$, $\pm 157.5^\circ$, 180° on the right side of the target (Fig. 4). γ -ray detectors are located around the target. The detectors ensure measurements of coincidences of prompt fission γ rays with fission fragments at angles of $\pm 22.5^\circ$, $\pm 67.5^\circ$, $\pm 112.5^\circ$, and $\pm 157.5^\circ$ with respect to the mean axis of the detection of fragments. Double hits in the γ detectors could not be distinguished electronically. They were recorded as single pileup events and were not treated in any special way. Coincidence pulses from eight independent plastic detectors with each pulse from ten segments of the stop detector form 16 different angles between the axes of fission fragments and γ detectors in the experiment:

$$\theta = Pl_{\text{ang}} - FF_{\text{ang}} \quad (2)$$

where FF_{ang} and Pl_{ang} are the angular positions of the segments of the fission fragment stop detector and γ -ray plastic detectors, respectively.

A. Methodology of sign determination

Generally, in the algorithm for processing the obtained data, the positive sign of the measured asymmetry at 45° (see Figs. 1 and 2) is associated with the right-handed rotation of the fissile nucleus, which occurs when the polarization direction of the fissile nucleus coincides with the polarization direction of the neutron beam. Denoting the γ -ray counting rates for the selected angle between the detectors in two opposite directions of neutron polarization as $N^+(\theta)$ and $N^-(\theta)$, respectively, we introduce the asymmetry

$$D(\theta) = \frac{N^+(\theta) - N^-(\theta)}{N^+(\theta) + N^-(\theta)}. \quad (3)$$

In Eq. (3), we assume that $N^+(\theta)$ corresponds to the spin parallel to the beam direction (right polarization) and $N^-(\theta)$ to the spin antiparallel to the beam direction (left polarization).

In order to correctly determine the sign of the measured asymmetry, it is necessary to follow all transformations of the neutron spin from the polarizer to the analyzer. It is imperative to determine which states correspond to $N^+(\theta)$ and $N^-(\theta)$ in reality. First, we determine the initial direction of the neutron spin after the polarizer. The magnetic field in SEOP was directed vertically downward (experimentally defined as the direction of the red compass needle). However, the polarization of ^3He nuclei in the cell was directed against the SEOP field. This means that the spin direction of the neutron beam after the polarizer coincides with the polarization of the ^3He gas, since for a sufficiently thick ^3He layer almost all neutrons with antiparallel spin orientation will be absorbed, while almost all neutrons with parallel orientation will pass through the layer of this gas.

After the polarizer, the neutrons pass through the spin-control system. Two similar devices S1 and S2 have been used in immediate vicinity to the fission chamber: one between the polarizer and the fission chamber to control the incoming polarization vector (as a spin-flipper) and another one after the fission chamber before the analyzer in order to

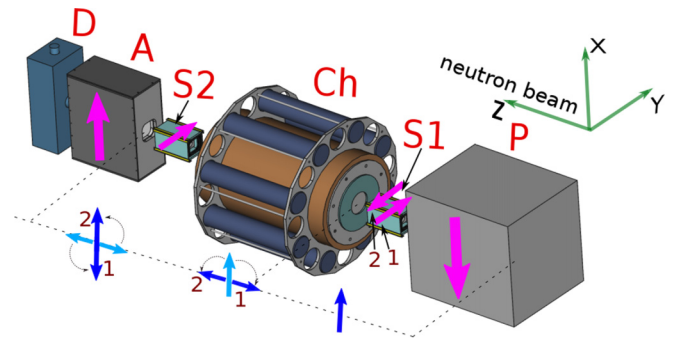

FIG. 6. The direction of the magnetic field and the neutron spin in the space between the polarizer and the analyzer. P: SEOP polarizer; Ch: fission chamber; A: analyzer; D: neutron detector; S1, S2: spin control coils. The blue arrow in the figure indicates the direction of the magnetic field, the red arrow direction of the neutron spin.

monitor the polarization value and calibrate the setup (see Fig. 6). The magnetic field inside both devices is directed horizontally and perpendicular to the neutron beam. Incoming vertical polarization precesses around the field by 90° toward the beam propagation direction. By flipping the field direction in the coil the spin is turned backwards or antiparallel to the beam propagation. In this way, by alternating the current in this coil, the incoming polarization is flipped by 180° every 1.3 s. The device in front of the analyzer was used to measure the polarization; it turns the neutron spins by $\pi/2$ around the z axis, always in the same direction. Thus, the beam polarization becomes parallel or antiparallel to the vertical analyzer field. The analyzer is completely analogous to the polarizer; it passes only neutrons whose spins are parallel to the spins of ^3He nuclei. In the analyzer cell, the polarization of ^3He nuclei is also directed against the analyzer field. According to Fig. 6 the neutron detector after the analyzer should count more when the neutron spin on the target is directed against the neutron momentum (left polarization), and less when the spins is directed along the neutron momentum.

Data from all detectors were recorded during the 1.3 s interval up to the next spin flip, i.e., stored along with the information about the direction of neutron beam polarization. Opposite directions of the neutron spin are recorded in the data files as 0 and 1. From these files, it was determined that the neutron counter after the analyzer counts more when the spin is 0. This means that the spin value 0 in the data file corresponds to the state when the neutron spin is directed against the neutron momentum.

IV. RESULTS AND DISCUSSION

Following the works [9,10], the ROT effect is the direct consequence of the appearance in the rupture process of a strongly deformed fissioning system with large angular momenta of the fission fragments [13]. These momenta, which are oriented perpendicular to the fission fragment axis of symmetry, are conserved up to the time of the γ -quanta emission ($\geq 10^{-14}$ s) and lead to the well known angular anisotropy of

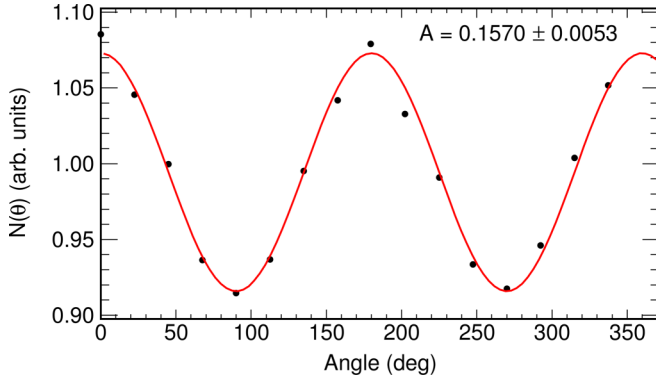
FIG. 7. Angular distribution of γ rays relative to the fission axis.

the γ -quanta emission relative to the fission axis:

$$N(\theta) \sim 1 + A \cos^2(\theta), \quad (4)$$

where A is the coefficient of the angular anisotropy related to the large angular momenta of the FFs. The coefficient of angular anisotropy A was also measured in this work and corresponds to the same γ -ray energy interval and the same geometrical configuration of detectors that was used for the ROT effect for prompt γ -quanta observation (Fig. 7).

Using the expressions (3) and (4), after some simple transformations one can get the following formula for the ROT asymmetry coefficient value:

$$D(\theta) \approx \frac{-A\delta_{FF} \sin(2\theta)}{1 + A \cos^2 \theta}, \quad (5)$$

where δ_{FF} is angle of rotation of the fission axis as shown in Fig. 1(b). The coefficient of the angular anisotropy was found to be $A = 0.1570 \pm 0.0053$ by fitting the angular distribution of the prompt γ rays emitted in binary fission by formula (5).

To determine the effects of the T -odd asymmetry for prompt γ rays in fission, calculated by Eq. (3), we used a specially written computer program [26]. Figure 8 shows the obtained angular dependence approximated by the following function:

$$D(\theta) = R_\gamma \sin(2\theta), \quad (6)$$

where R_γ is the asymmetry parameter. For prompt γ quanta from fission of ^{235}U by “warm” polarized neutrons, the asymmetry parameter was found to be $R_\gamma = -(17.3 \pm 2.8) \times 10^{-5}$ (see Fig. 8).

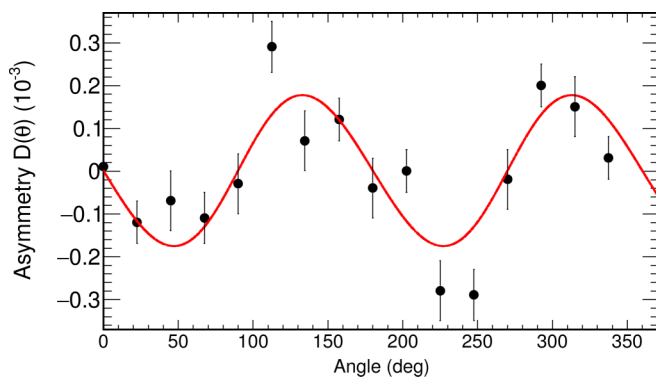
FIG. 8. Asymmetry ratio D as a function of angle for the γ rays.

Comparing 5 and 6 one can write $\delta_{FF} = -R_\gamma(1 + A \cos^2 \theta)/A$. This angle characterizes the rotation of the fission axis in binary fission, corresponding to the angular shift for the γ -quanta angular distribution. Finally, the rotation angle is $\delta_{FF} = 0.069^\circ \pm 0.008^\circ$ for the case of ^{235}U binary fission with the subsequent emission of γ quanta.

According to [27] angular velocities for two values of the ^{236}U compound nucleus, $J = 4$ and $J = 3$, have different signs, indicating opposite directions of fissioning system rotation. But the sign and size of the effective angular velocity and, therefore, the sign and magnitude of the ROT effect also depend on the partial fission cross sections; more precisely, on their ratio. In the thermal neutrons region the partial fission cross section for $J = 4$ is approximately 2 times larger than the corresponding value for $J = 3$. Furthermore the positive partial angular velocity of the state $J = 4$ exceeds in absolute value the negative rotational speed of the compound state $J = 3$. As a result, in this region a positive and sizable value of the ROT effect was obtained [10]. Practically the same results were expected for “warm” neutrons, where the partial cross-section ratios were approximately the same.

The obtained result can be compared to the corresponding value for ^{235}U , obtained with thermal neutrons in [10] $\delta_{FF} = 0.103^\circ \pm 0.028^\circ$. It follows that the effect is somewhat smaller than that in thermal neutron-induced fission, though it can be also stated that they coincide within the error limits. The obtained rotation angle for binary fission can be also compared to the the rotation angle of the fission axis for ternary fission: $\delta_{FF}(\text{TF}) = 0.18^\circ \pm 0.02^\circ$ [27]. We confirm the conclusions of the authors of [27] that both angles of rotation of the fission axis in ternary and binary fission have the same sign, and the absolute value of the angle is somewhat smaller in the binary case. This may be an indication of different scission configuration in these two cases, resulting in different average moments of inertia of the fragments. The smaller value of the fission axis rotation angle obtained for the γ ROT effect in binary fission may be also connected with the mechanism of fragment spin formation. As suggested in [28], fragment spins are generated in the post-scission phase as two independent torques caused by snapping of the nucleons forming the neck region. In this case, our initial statement that fission fragment angular momenta, and consequently γ -ray angular distribution, are oriented relative to the fission axis deformation as scission and do not rotate with the fragments, appears not completely true. If the spins of the fragments are formed after scission, the axis of the fragment spin alignment can also slightly rotate which will result in the smaller observed ROT effect and smaller angle of rotation of the fission axis, determined by such method.

V. CONCLUSIONS

The ROT effect was measured in the angular distributions of prompt γ rays from the fission of ^{235}U nuclei induced by monochromatic polarized “warm” neutrons. This effect is expressed in the rotation of the corresponding angular distribution relative to the axis of the fragment emission in the case of fission of a polarized nucleus.

Obtained results provide new evidence that the ^{236}U compound nucleus, through which the fission reaction of the ^{235}U nucleus by “warm” polarized neutrons occurs, is in a state of collective rotation, which is transferred to fission fragments in the form of orbital angular momentum. This result is of great importance for understanding the fission mechanism and can be useful for theoretical calculations of fission barriers.

The value δ_{FF} was also found, which characterizes the angle of rotation of the fission axis. This value of the rotation angle of the fission axis in binary fission of ^{235}U is of great importance for assessing the ROT effect. It should be noted that there is a difference between the rotation angle of the fission axis in the ternary fission and the rotation angle observed in this experiment. The latter angle is 2.5 times smaller than that for α particles from ternary fission [27]. In the experiment to measure the ROT effect in binary fission, we do not have a deflection of the γ rays (as in ternary fission from α particle) and, therefore, we can only register the rotation of the fission

axis. An accurate correlation between the two rotational angles of the fission axis (in binary and ternary fission) can help to clarify these fission configurations.

ACKNOWLEDGMENTS

This work has been supported by the Ministry of Education and Science of the Russian Federation, German Ministry for Education and Research BMBF through the project 05K13PA3 and partially supported by the Science Development Foundation under the President of the Republic of Azerbaijan, Grant No. EIF-BGM-5-AZTURK-1/2018-2/01/1-M-01. The instrument POLI is operated by RWTH Aachen in cooperation with JCMS FZ Jülich (Jülich Aachen Research Alliance JARA). We are grateful to K. Lehmann, W. Lubertetter, and P. Stein for their help in setting up and conducting the experiment.

-
- [1] A. Barabanov, *Symmetry and Spin-Angular Correlations in the Reactions and Decays / Simmetrii i spin-uglovyie korrelyatsii v reaktsiyakh i raspadakh (Russian)* (FizMatLit, Moscow, 2010).
- [2] G. Danilyan, B. Vodennikov, V. Dronyaev, V. Novitskii, V. Pavlov, and S. Borovlev, *Pis'ma Zh. Eksp. Teor. Fiz.* **26**, 197 (1977) [*JETP Letters* **26**, 186 (1977)].
- [3] P. Jesinger, G. Danilyan, A. Gagarski, P. Geltenbort, F. Goennenwein, A. Kotzle, Y. Korobkina, M. Mutterer, V. Nesvizhevsky, S. Neumaier, V. Pavlov, G. Petrov, V. Petrova, K. Schmidt, V. Shvachkin, and O. Zimmer, *Yad. Fiz.* **62**, 1723 (1999) [*Phys. At. Nucl.* **62**, 1508 (1999)].
- [4] P. Jesinger, A. Kotzle, A. Gagarski, F. Goennenwein, G. Danilyan, V. Pavlov, V. Chvatchkin, M. Mutterer, S. Neumaier, G. Petrov, V. Petrova, V. Nesvizhevsky, O. Zimmer, P. Geltenbort, K. Schmidt, and K. Korobkina, *Nucl. Instrum. Methods Phys. Res. A* **440**, 618 (2000).
- [5] G. Danilyan, A. Fedorov, A. Gagarski, F. Goennenwein, P. Jesinger, J. Kalben, A. Kotzle, Y. Korobkina, I. Krasnoschekova, M. Mutterer, V. Nesvizhevsky, S. Neumaier, Y. Novozhilov, V. Pavlov, G. Petrov, V. Petrova, S. Solovyev, W. Trzaska, and O. Zimmer, *Phys. At. Nucl.* **63**, 1671 (2000).
- [6] F. Goennenwein, M. Mutterer, A. Gagarski, I. Guseva, G. Petrov, V. Sokolov, T. Zavarukhina, Yu. Gusev, J. von Kalben, V. Nesvizhevski, T. Soldner, *Phys. Lett. B* **652**, 13 (2007).
- [7] I. S. Guseva and Yu. I. Gusev, *Bull. Russ. Acad. Sci. Phys.* **71**, 367 (2007).
- [8] A. Gagarski, G. Petrov, I. Guseva, T. Zavarukhina, F. Goennenwein, M. Mutterer, J. Kalben, Y. Kopatch, G. Tiourine, W. Trzaska, M. Sillanpaa, T. Soldner, and V. Nesvizhevsky, in *4th International Workshop on Nuclear Fission and Fission-Product Spectroscopy*, 13–16 October 2009, edited by A. Chatillon, H. Faust, G. Fioni, D. Goutte, and H. Goutte, AIP Conf. Proc. No. 1175 (AIP, New York, 2009), p. 323.
- [9] G. V. Danilyan, J. Klenke, V. A. Krakhotin, V. L. Kuznetsov, V. V. Novitsky, V. S. Pavlov, and P. B. Shatalov, *Phys. At. Nucl.* **72**, 1812 (2009).
- [10] G. V. Valsky, A. M. Gagarski, I. S. Guseva, D. O. Krinitsin, G. A. Petrov, Yu. S. Pleva, V. E. Sokolov, V. I. Petrova, T. A. Zavarukhina, and T. E. Kuzmina, *Bull. Russ. Acad. Sci. Phys.* **74**, 767 (2010).
- [11] G. Petrov, *Sov. Phys. JETP* **20**, 1387 (1965).
- [12] Yu. N. Kopach, P. Singer, M. Mutterer, M. Klemens, A. Hotzel, D. Schwalm, P. Thierolf, M. Hesse, and F. Gonnenswein, *Phys. Rev. Lett.* **82**, 303 (1999).
- [13] J. B. Wilhelmy, E. Cheifetz, R. C. Jared, S. G. Thompson, H. R. Bowman, and J. O. Rasmussen, *Phys. Rev. C* **5**, 2041 (1972).
- [14] V. Strutinskii, *Zh. Eksp. Teor. Fiz.* **37**, 861 (1959).
- [15] G. V. Danilyan, J. Klenke, V. A. Krakhotin, Yu. N. Kopach, V. V. Novitsky, V. S. Pavlov, and P. B. Shatalov, *Phys. At. Nucl.* **74**, 671 (2011).
- [16] G. V. Danilyan, J. Klenke, Yu. N. Kopach, V. A. Krakhotin, V. V. Novitsky, V. S. Pavlov, P. B. Shatalov, *Phys. At. Nucl.* **77**, 677 (2014).
- [17] Yu. Kopatch, V. Novitsky, G. Ahmadov, A. Gagarski, D. Berikov, G. Danilyan, V. Hutanu, J. Klenke, and S. Masalovich, *EPJ Web Conf.* **169**, 00010 (2018).
- [18] Yu. Kopatch, V. Novitsky, G. Ahmadov, A. Gagarski, D. Berikov, K. Zhumadilov, G. Danilyan, V. Hutanu, J. Klenke, and S. Masalovich, in *Proceedings of the XXV International Seminar on Interaction of Neutrons with Nuclei*, Dubna, Russia, May 22–26, 2017 (JINR, Dubna, 2018), p. 397.
- [19] V. Hutanu, M. Meven, and G. Heger, *Phys. B: Condens. Matter* **397**, 135 (2007).
- [20] V. Hutanu, *J. Large-Scale Res. Facil.* **1**, A16 (2015).
- [21] V. Hutanu, S. Masalovich, M. Meven, O. Lykhvar, G. Borchert, and G. Heger, *Neutron News* **18**, 14 (2007).
- [22] V. Hutanu, M. Meven, S. Masalovich, G. Heger, and G. Roth, *J. Phys.: Conf. Ser.* **294**, 012012 (2011).
- [23] Z. Salhi, E. Babcock, K. Bingöl, K. Bussmann, H. Kammerling, V. Ossovyi, A. Heynen, H. Deng, V. Hutanu, S. Masalovich, J. Voigt, and A. Ioffe, *J. Phys.: Conf. Ser.* **1316**, 012009 (2019).
- [24] V. Hutanu, M. Meven, A. Sazonov, and G. Heger, *Meas. Sci. Technol.* **19**, 034010 (2008).
- [25] D. Berikov, V. Hutanu, Yu. Kopatch, G. Ahmadov, A. Gagarski, V. Novitsky, G. Danilyan, S. Masalovich, J. Klenke, and H. Deng, *J. Instrum.* **15**, P01014 (2020).
- [26] D. Berikov, G. Ahmadov, Yu. Kopatch, K. Zhumadilov, *Eurasian J. Phys. Funct. Mater.* **4**, 114 (2020).
- [27] I. S. Guseva, A. M. Gagarski, Yu. I. Gusev, G. A. Petrov, and G. V. Valsky, *Phys. Part. Nucl. Lett.* **10**, 331 (2013).
- [28] J. N. Wilson, D. Thisse, M. Lebois *et al.*, *Nature (London)* **590**, 566 (2021).