

Theoretical search for the nested quantum Hall effect of composite fermions

Sudhansu S. Mandal and Jainendra K. Jain

Department of Physics, 104 Davey Laboratory, The Pennsylvania State University, University Park, Pennsylvania 16802

(Received 25 June 2002; published 1 October 2002)

Almost all quantum Hall effect to date can be understood as *integral* quantum Hall effect of appropriate particles, namely, electrons or composite fermions. This paper investigates theoretically the feasibility of nested states of composite fermions which would lead to a quantum Hall effect that cannot be understood as integral quantum Hall effect of composite fermions. The weak residual interaction between composite fermions will play a crucial role in the establishment of such quantum Hall states by opening a gap in a partially filled composite-fermion level. To treat the problem of interacting composite fermions, we develop a powerful method that allows us to obtain the low-energy spectra at composite-fermion fillings of $\nu^* = n + \bar{\nu}$ without making any assumption regarding the structure of composite fermions in the topmost partially filled level. The method is exact aside from neglecting the composite-fermion Landau level mixing, and enables us to study rather large systems, for example, 24 particles at a total flux of $62 hc/e$, for which the dimension of the lowest Landau level Hilbert space is $\sim 10^{17}$. We have investigated, for fully spin-polarized composite fermions, several filling factors between $1/3$ and $2/5$ using this approach. The results indicate that any possible incompressibility at these fractions is likely to have a fundamentally different origin than that considered earlier.

DOI: 10.1103/PhysRevB.66.155302

PACS number(s): 71.10.Pm, 73.43.-f

I. INTRODUCTION

If electrons did not interact, only the integral quantum Hall effect¹ (IQHE) would occur in nature. The discovery of the fractional quantum Hall effect² (FQHE) signaled the existence of a correlated state of matter, the essence of which lies in the formation of quantum particles called composite fermions,³ which are bound states of electrons and an even number of quantized vortices. Electrons avoid each other most efficiently by turning into composite fermions, which, in turn, interact much more weakly than electrons. For a large number of phenomena, it is a valid first approximation to neglect the interaction between composite fermions altogether, indicating that the interaction between composite fermions can often be treated perturbatively and does not cause any phase transitions.

The fundamental property of composite fermions, which is responsible for the dramatic phenomenology of two-dimensional systems in high magnetic fields, is that as they move about, the Aharonov Bohm phase is partly canceled by the phase produced by the vortices tied to other composite fermions and as a result they experience an *effective* magnetic field B^* given by

$$B^* = B - 2p\rho\phi_0, \quad (1)$$

where B is the external magnetic field, ρ is the electron density (in two dimensions), the even integer $2p$ is the vorticity of composite fermions (CF's), and $\phi_0 = hc/e$. (The composite fermion with vorticity $2p$ is denoted by ^{2p}CF or $\text{CF-}2p$.) They form Landau-like levels in this reduced magnetic field, with their filling factor (ν^*) related to the electron filling factor (ν) by

$$\nu = \frac{\nu^*}{2p\nu^* \pm 1}. \quad (2)$$

The wave functions for composite fermions are given by³

$$\Psi_\nu = P_{LLL} \prod_{j < k} (z_j - z_k)^{2p} \Phi_{\nu^*}, \quad (3)$$

where $z_j = x_j - iy_j$ denotes the position of the j th particle, Φ_{ν^*} is an antisymmetric wave function for fermions at the effective filling ν^* , and P_{LLL} is the lowest Landau level (LLL) projection operator. The wave function Ψ_ν is of course the wave function of correlated electrons at ν , but can also be interpreted as the wave function of composite fermions at filling factor ν^* , because on the right-hand side, each electron has $2p$ vortices bound to it through the multiplicative factor $\prod_{j < k} (z_j - z_k)^{2p}$, which converts each electron into a composite fermion.

Let us begin by neglecting the interaction between composite fermions. In this case, a gap opens up when the composite fermions fill an integral number of levels, i.e., when $\nu^* = n$, which corresponds to electron filling factors given by

$$\nu = \frac{n}{2pn + 1}, \quad (4)$$

where n is a positive or negative integer. [The negative values of n give $\nu = |n|/(2p|n| - 1)$, and correspond to the situation in which the effective field B^* is opposite to the external field B .] The model of noninteracting composite fermions thus predicts quantum Hall effect (QHE) of electrons at these fractions, and also at

$$\nu = 1 - \frac{n}{2pn + 1} \quad (5)$$

due to particle-hole symmetry in the lowest Landau level. [The fractions in Eq. (5) can be obtained by formulating the problem in terms of *holes* rather than electrons in the lowest Landau level, and then making composite fermions out of them.] The QHE at these filling factors will be termed “CF-

$2p$ QHE.” CF-2 QHE, and CF-4 QHE are routine, and CF-6 QHE and CF-8 QHE have also been observed.^{4,5} These sequences exhaust most of the more than 50 observed fractions to date in the lowest Landau level. The wave functions have been tested in detail for finite systems, and are very accurate, without involving any adjustable parameter.^{3,6–8}

In short, most of the QHE can be understood as the integral QHE of appropriate fermions. It ought to be noted that the QHE of higher-order composite fermions can be viewed as a consequence of interactions between lower-order composite fermions. For example, the CF-4 QHE originates from interactions between CF-2’s. Nonetheless, the physics of all states at filling factors of Eqs. (4) and (5) is correctly described in terms of non-interacting composite fermions of the appropriate kind.

While the above fractions are obtained most immediately in the CF theory, it has been known since the very beginning of the composite-fermion theory that other fractions are not ruled out.^{3,9} New QHE *between* two successive integral Hall states of composite fermions will be called NQHE, where N stands for “nested.” A simple scenario for NQHE is as follows. Consider electrons in the filling factor range

$$\frac{n+1}{2p(n+1)+1} > \nu > \frac{n}{2pn+1}, \quad (6)$$

which map into 2^p CF’s in the range

$$n+1 > \nu^* > n \quad (7)$$

containing n levels fully occupied and the $(n+1)$ th level partially occupied. It is a natural conjecture that inter-CF interaction can possibly cause gaps at

$$\nu^* = n + \frac{\bar{n}}{2\bar{p}\bar{n}+1} \quad (8)$$

which will produce new fractions between the familiar fractions $n/(2pn+1)$ and $(n+1)/[2p(n+1)+1]$. Here, the 2^p CF’s in the topmost partially filled level capture $2\bar{p}$ vortices (as a result of the residual 2^p CF- 2^p CF interaction) to turn into higher-order composite fermions ($2^{p+2\bar{p}}$ CF’s) and condense into \bar{n} levels, thereby opening a gap and producing quantum Hall effect. This QHE state is a nested state with higher-order composite fermions forming in the background of the original composite fermions.

Certain qualitative consequences of the above scenario are as follows. The NQHE of composite fermions is analogous to QHE of electrons between two successive IQHE states of electrons, that is, to FQHE in *higher* electronic Landau levels. It is known that FQHE is rare in second electronic Landau levels (i.e., in the range $4 > \nu > 2$, including spin degeneracy) and nonexistent in third or higher Landau levels; by analogy, NQHE is expected to be rare. Extending the analogy further, the strongest NQHE states for fully spin-polarized composite fermions are expected to be at $\nu^* = 1 + 1/3$ and $\nu^* = 1 + 2/3$, which correspond to electron filling factors $\nu = 4/11$ and $\nu = 5/13$; these are expected to be the strongest nested CF states.^{3,9}

Recently, Pan *et al.*¹⁰ have reported observation of $4/11$ and $5/13$, heralding a new generation of quantum Hall effect that cannot be understood as the IQHE of composite fermions. This discovery has given fresh impetus to the issue of NQHE, especially because it is possible that more NQHE states will be observed in the future as the sample quality improves and the temperature drops, reminiscent of how the FQHE appeared on top of the IQHE. What other nested states are possible? What is the true nature of these states? Such questions have motivated us to investigate this topic further.

Even though the theoretical scenario described above is plausible, and indeed natural, there is no *a priori* guarantee that it actually occurs, and it is important to carry out quantitative tests to ascertain its applicability to the real world. It is worth recalling here that not all fractions that can occur *in principle* do really occur in nature. For example, FQHE can occur for some hypothetical interaction at very small filling factors, but is preempted by Wigner crystal for the Coulomb interaction, and in higher Landau levels the FQHE is often believed to be unstable to charge-density-wave-type state. Therefore, it would require further theoretical work before one could claim with any degree of confidence that NQHE based on the physics described above is actually possible.

The quantitative theoretical investigations so far suggest that there should be *no* FQHE at fractions other than those in Eqs. (4) and (5) for fully spin-polarized electrons. An exact diagonalization study¹¹ of $N=8$ electrons at $4/11$ finds a nonuniform ground state, which is an evidence against FQHE liquid. In another approach,^{11,12} a model has been developed for the effective interaction between composite fermions in the second level. In Ref. 11 it was argued that no new FQHE is obtained.¹¹ Reference 12 found that the form of this interaction favors a “bubble crystal” of composite fermions at filling factors like $4/11$ rather than the quantum Hall effect. These studies indicate that the effective interaction between composite fermions is not sufficiently strongly repulsive to stabilize FQHE at $4/11$ and several other fractions. Both approaches have their problems. In exact diagonalization, the system is effectively small, with only ~ 3 composite fermions in the second level, and one may question if the conclusion based on this system will hold up as N increases. The effective interaction model involves several assumptions, because of which the results are plausible but not conclusive.

Reference 13 showed that FQHE at $4/11$ is very likely possible for a *partially* spin-polarized system or a spin-unpolarized system. It is not yet known for sure if the FQHE states at $4/11$ and $5/13$ are partially or fully polarized in the experiments of Pan *et al.*,¹⁰ but given the relatively high magnetic fields at which these states have been observed, it is quite possible that they are fully spin polarized, and therefore it is worth revisiting the issue of whether fully polarized incompressible states can be found theoretically at these filling fractions. That is the prime motivation behind our present study. In this work, we will look for FQHE at several filling fractions in the range between $1/3$ and $2/5$.

We will study finite systems of N particles at total flux $2Q$ (in units of the flux quantum $\phi_0 = hc/e$), where the relation

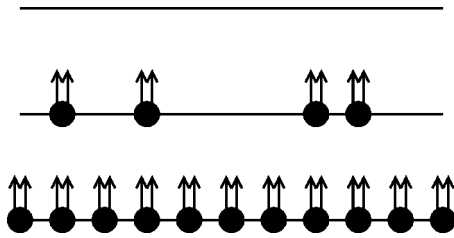

FIG. 1. The configurations included in our study. Each composite fermion is depicted as an electron carrying two flux quanta. The lowest composite-fermion level is fully occupied and the second one is partially occupied.

between N and Q for a given filling factor will be derived from the physics described above. The most reliable theoretical method would be exact diagonalization. However, because of the exponentially growing Hilbert space, exact diagonalization is possible only for very small systems, and very few filling factors. For example, for $\nu=4/11$, exact diagonalization has been possible for $N=8$ electrons.¹⁴ The next system contains $N=12$ (in the spherical geometry, discussed below), for which the lowest Landau level Hilbert space contains a total of 8.6×10^7 Slater determinant basis states; the diagonalization of matrices of such sizes is beyond the reach of present day computers. We have developed a powerful method, namely, diagonalization in low-energy composite-fermion basis (LECFB), which we believe gives accurate results. It exploits the fact that the composite-fermion theory allows us to directly identify low-energy states of the full Hilbert space, which lets us work within a subspace much smaller than the full Hilbert space. For example, we have been able to obtain the low-energy spectrum for the $4/11$ state with as many as 24 electrons, where the dimension of the full Hilbert space is $\sim 10^{17}$.

A brief outline of the method is as follows. Consider the filling factor range given in Eq. (6). Given that the two ends of this range are well described as $n+1$ and n filled levels of composite fermions, it is natural to expect that the low-energy states at ν contain n composite-fermion levels completely occupied, and the remaining composite fermions in the $(n+1)$ th level. The configurations that involve promotion of composite fermions to higher kinetic energy levels are expected to cost substantially higher energy and are neglected. In other words, we include all configurations of type shown in Fig. 1, but neglect configurations of the type shown in Fig. 2. This neglect of composite-fermion Landau level mixing is the only assumption in our approach, which can be tested for consistency at the end of the calculation. Other than that, the method is exact. The most important point here is that we do not make any assumption with regard to the interaction between composite fermions, or their structure in the partially filled level. In our calculation, we first construct all states of composite fermions at $\nu^* = n + \bar{\nu}$, with the lowest n levels fully occupied and the next one with filling factor $\bar{\nu}$, and then diagonalize the Coulomb Hamiltonian within this sector to obtain the spectrum of low-energy states. The

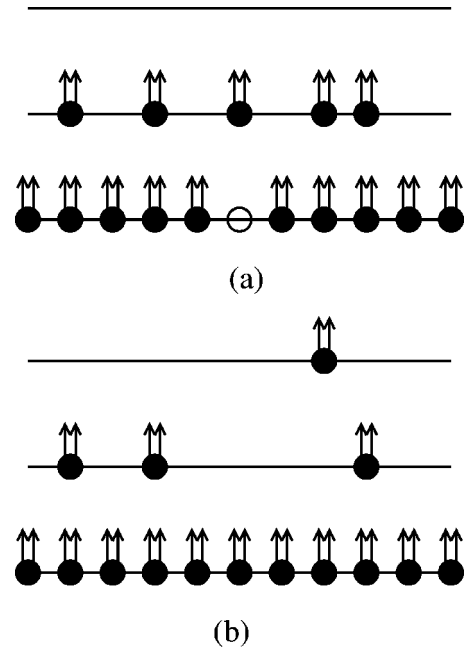

FIG. 2. The configurations neglected in our study. These have higher “kinetic” energy than the configurations shown in Fig. 1.

calculation is rather involved, requiring extensive Monte Carlo; but is still numerically stable, and yields reliable results.

The present method is a significant advance over the variational method of Ref. 12. It is much more reliable because it eliminates several approximations made in that work. In Ref. 12, the problem of composite fermions at $\nu^* = n + \bar{\nu}$ was mapped into that of fermions at $\bar{\nu}$. Further, it was assumed that the interaction energy of the system of composite fermions in the partially filled level can be approximated by a sum of two-body interactions. The interaction between composite fermions was obtained by keeping only two composite fermions in the $(n+1)$ th level and integrating out the composite fermions of the lower filled levels. In general, when there are many composite fermions in the $(n+1)$ th level, the integrating out of the lower-level composite fermions will produce a quite complex interaction, with two-, three-, and n -body terms, because the full system is strongly correlated. The hope was that the n -body terms will produce the correct state. However, this approximation was untested. Finally, the method was a variational study, in which the energies of certain wave functions were compared to determine which had the lowest energy; there was, of course no guarantee that this state would describe the true ground state. In contrast, in the present study, we work with the full composite-fermion system and do not assume anything about the form of the interaction between composite fermions or the nature of their ground state.

The following section contains a discussion of how we construct the low-energy composite fermion basis and how we carry out the Gram-Schmid orthogonalization and diagonalization. The reader not interested in the technical details

can skip this section and directly proceed to the subsequent section, wherein the results are given and their implications are discussed.

II. DIAGONALIZATION IN LOW-ENERGY COMPOSITE-FERMION BASIS

We first summarize certain relevant facts from the Introduction. The electron filling factor ν given by

$$\nu = \frac{\nu^*}{2p\nu^* \pm 1} \quad (9)$$

corresponds to composite-fermion filling factor ν^* . We will be interested below in the specific values of ν^* given by

$$\nu^* = n + \bar{\nu} = n + \frac{\bar{n}}{2\bar{p}\bar{n} + 1}. \quad (10)$$

Here, composite fermions fill n levels completely and occupy $\bar{\nu}$ fraction of the $(n+1)$ th level. If the ^{2p}CF 's in the partially occupied level capture $2\bar{p}$ additional vortices and condense into \bar{n} filled Landau level state, then a gap would open up and NQHE would be obtained. The question is whether this mechanism really occurs in nature.

In the composite-fermion theory, there are several possible approaches for constructing a low-energy basis. In this work, we construct a LECFB of *all* states at $\nu^* = n + \bar{\nu}$ in which n ^{2p}CF levels are fully occupied and the next level has filling $\bar{\nu}$. We do not make any approximation regarding the structure of ^{2p}CF 's in the partially filled level. This basis is, in principle, straightforward: we simply need to take all *electronic* states at $\nu^* = n + \bar{\nu}$ and attach $2p$ vortices to obtain the composite-fermion states. The method, however, is technically rather demanding, and the present section is devoted to it.

A. Wave functions

We will employ the spherical geometry in which N electrons move on the surface of a sphere under the influence of a radial magnetic field B created by a magnetic monopole at the center. The magnitude of the B field is given by $2Q\phi_0/4\pi R^2$, where $\phi_0 = hc/e$ is known as the flux quantum, R is the radius of the sphere, and Q is called the monopole strength that should be either an integer or a half-integer because of Dirac's quantization condition.

The interacting electron system at monopole strength Q maps into a system of weakly interacting composite fermions at an effective monopole strength $q^* = Q - p(N-1)$. The wave functions for interacting electrons at Q are given by

$$\Psi_Q = P_{LLL} \Phi_1^{2p} \Phi_{q^*}, \quad (11)$$

where Φ_1 is the wave function for the fully occupied lowest Landau level, and Φ_{q^*} are antisymmetric wave functions at q^* . Φ is, in general, a linear superposition of Slater-determinant basis states made up of the monopole harmonics, $Y_{q^*,s,m}$, given by¹⁵

$$Y_{q^*,s,m}(\Omega_j) = N_{q^*sm} (-1)^{q^*+s-m} e^{iq^*\phi_j} u_j^{q^*+m} v_j^{q^*-m} \\ \times \sum_{r=0}^s (-1)^r \binom{s}{r} \binom{2q^*+s}{q^*+s-m-r} \\ \times (v_j^* v_j)^{s-r} (u_j^* u_j)^r, \quad (12)$$

where

$$N_{q^*sm} = \left(\frac{(2q^*+2s+1)}{4\pi} \frac{(q^*+s-m)!(q^*+s+m)!}{s!(2q^*+s)!} \right)^{1/2}. \quad (13)$$

The quantity $s=0,1,2,\dots$ is the Landau level (LL) index, to be differentiated from n , the number of filled Landau levels. Ω_j represents the angular coordinates θ_j and ϕ_j of the j th electron, and

$$u_j \equiv \cos(\theta_j/2) \exp(-i\phi_j/2) \quad (14)$$

$$v_j \equiv \sin(\theta_j/2) \exp(i\phi_j/2). \quad (15)$$

It was shown in Ref. 7 that Ψ_Q , the wave function of interacting electrons at $Q = q^* + p(N-1)$, is obtained from Φ_{q^*} by replacing $Y_{q^*,s,m}$ by $Y_{q^*,s,m}^{CF}$, defined as

$$Y_{q^*,s,m}^{CF}(\Omega_j) = N_{q^*sm} (-1)^{q^*+s-m} \\ \times \frac{(2Q+1)!}{(2Q+s+1)!} u_j^{q^*+m} v_j^{q^*-m} \\ \times \sum_{r=0}^s (-1)^r \binom{s}{r} \binom{2q^*+s}{q^*+s-m-r} u_j^r v_j^{s-r} \\ \times \left[\left(\frac{\partial}{\partial u_j} \right)^r \left(\frac{\partial}{\partial v_j} \right)^{s-r} J_j^p \right], \quad (16)$$

where

$$J_j = \prod_k' (u_j v_k - v_j u_k). \quad (17)$$

Here the prime denotes the condition $k \neq j$.

B. Low-energy composite-fermion basis

For $\bar{\nu}=0$, that is at the special filling factors

$$\nu = \frac{n}{2pn \pm 1}, \quad (18)$$

the wave function for the ground state has the simple form

$$\Psi_n^{GS} = P_{LLL} \Phi_1^{2p} \Phi_n, \quad (19)$$

where Φ_n is the Slater-determinant wave function for n filled Landau levels. Since Φ_n is unique, the wave function $\Psi_{n/(2pn \pm 1)}$ also contains no adjustable parameters. It has been tested in the past and was found to be remarkably accurate.^{6,7}

Of interest in this work is the situation when $\bar{\nu} \neq 0$. Here, we obtain the low-energy spectrum through the following steps.

(1) We perform exact diagonalization for \bar{N} particles at filling factor $\bar{\nu}$ in the lowest Landau level to get all eigenstate. The form of the interaction used for the diagonalization is of no significance, because its only role is to produce basis wave functions, but we work with the Coulomb interaction. Let us denote these states by $\Phi_{\bar{\nu}}^{\alpha}$, where α labels different states.

(2) We then promote each eigenstate to the $(n+1)$ th Landau level, and fill the lower n Landau levels completely with additional particles to get the N -particle state at $\nu^* = n + \bar{\nu}$. This gives *all* wave functions $\Phi_{\nu^*}^{\alpha}$ for which the lowest n Landau levels are fully occupied and the next Landau level has filling $\bar{\nu}$. These states are denoted by $L_n \Phi_{\bar{\nu}}^{\alpha}$, where L_n denotes addition of n Landau levels. It ought to be remembered that the operator L_n changes the number of particles.

(3) We then multiply each wave function by Φ_1^{2p} and carry out the lowest Landau level projection by the method discussed in Sec. II A. This gives us correlated basis functions $\Psi_{\bar{\nu}}^{\alpha}$ at ν . These steps are summarized as

$$\bar{\nu} \Rightarrow \nu^* = n + \bar{\nu} \Rightarrow \nu = \frac{\nu^*}{2p\nu^* + 1}, \quad (20)$$

$$\Psi_{\bar{\nu}}^{\alpha} = P_{LLL} \Phi_1^{2p} L_n \Phi_{\bar{\nu}}^{\alpha}. \quad (21)$$

The advantage of constructing basis states in this way is that it directly gives us basis functions with well-defined orbital angular momentum L , which is a good quantum number in the spherical geometry. We can work within each L sector independently, because they are not coupled by the interaction. (Note that in the above equation, $\Phi_{\bar{\nu}}^{\alpha}$ is a wave function for \bar{N} electrons only.)

(4) The basis thus obtained is not orthogonal. We obtain an orthogonal basis following the Gram-Schmid procedure. Some relevant details are outlined below.

(5) We construct the Hamiltonian matrix.

(6) Diagonalization of the Hamiltonian gives the low-energy eigenspectrum at ν .

If an incompressible state is obtained, the ground-state wave function is likely to be well approximated by

$$P_{LLL} \Phi_1^{2p} L_n \Phi_{\bar{\nu}}^{GS} \approx P_{LLL} \Phi_1^{2p} L_n [P_{LLL} \Phi_1^{2\bar{p}} \Phi_{\bar{n}}^-], \quad (22)$$

where $\Phi_{\bar{\nu}}^{GS} \approx P_{LLL} \Phi_1^{2\bar{p}} \Phi_{\bar{n}}^-$ is the wave function for the ground state for \bar{N} particles at $\bar{\nu} = \bar{n}/(2\bar{p}\bar{n} + 1)$.

C. NQHE states on sphere

Since our goal is to look the feasibility of NQHE described above, we do our calculations at those values of Q where it is possible for ${}^{2p}\text{CF}$'s in the partially filled level to condense into a standard-type of FQHE state. For that, we first need to determine the relation between Q and N for a given filling factor. Clearly, in the limit $N \rightarrow \infty$ we must have

$$\lim_{N \rightarrow \infty} \frac{N}{2Q} = \nu, \quad (23)$$

where $2Q$ is the number of flux quantum. For finite systems, however, the ratio $N/2Q$ is not exactly equal to ν , and the identification of what filling factor a finite system corresponds to requires additional theoretical input.

Let us first consider the incompressible states at filling factor $\bar{\nu} = \bar{n}/(2\bar{p}\bar{n} + 1)$, the wave function for which is given by $\Phi_1^{2\bar{p}} \Phi_{\bar{n}}^-$. For these states, the relation between Q and N can be obtained by noting that the product of two monopole harmonics at q' and q'' gives a monopole harmonic at $q' + q''$, i.e., the monopole strengths add. For reasons that will become clear below, let us denote the number of particles by \bar{N} and the monopole strength by \bar{q} . The lowest LL projection is unimportant for the question of the relationship between \bar{N} and \bar{q} , as it does not alter \bar{q} . In the spherical geometry, for monopole strength q the degeneracy of the lowest Landau level is $2q + 1$, for the next LL it is $2q + 3$, and so on. From that, it is clear that the \bar{n} filled LL state is obtained for $q_{\bar{n}}$ given by

$$q_{\bar{n}} = \frac{\bar{N} - \bar{n}^2}{2\bar{n}}. \quad (24)$$

In particular, one filled LL is obtained at

$$q_1 = \frac{\bar{N} - 1}{2}. \quad (25)$$

From the addition rule, the monopole strength of $\Phi_1^{2\bar{p}} \Phi_{\bar{n}}^-$ is given by

$$\bar{q} = 2\bar{p}q_1 + q_{\bar{n}} = \left(\bar{p} + \frac{1}{2\bar{n}}\right)\bar{N} - \left(\bar{p} + \frac{\bar{n}}{2}\right). \quad (26)$$

It can be verified that $2\bar{q}/\bar{N}$ gives the filling factor $\bar{\nu}$ in the thermodynamic limit.

Now we ask what is the monopole strength q^* for the state at $\nu^* = n + \bar{\nu} = n + \bar{n}/(2\bar{p}\bar{n} + 1)$ for N electrons. Let us denote by \bar{N} the number of fermions in the $(n+1)$ th partially filled Landau level. In order for \bar{N} fermions to form the $\bar{n}/(2\bar{p}\bar{n} + 1)$ state, the degeneracy in this level must satisfy

$$2q^* + 2n + 1 = 2\bar{q} + 1, \quad (27)$$

which implies that

$$q^* = \bar{q} - n. \quad (28)$$

The total number of fermions, including the fermions in the lowest n fully occupied Landau levels is

$$N = \bar{N} + 2nq^* + n^2. \quad (29)$$

Eliminating \bar{N} , one gets the following relation between N and q^* :

$$N = 2q^* \left(n + \frac{\bar{n}}{2\bar{p}\bar{n}+1} \right) + \frac{\bar{p} + \frac{1}{2\bar{n}} + n}{\bar{p} + \frac{1}{2\bar{n}}} + n^2. \quad (30)$$

The state at $\nu^* = n + \bar{n}/(2\bar{p}\bar{n}+1)$ is obtained for all values of (N, q^*) related by the above equation, provided N is an integer and q^* is an integer or a half integer. The state at $\nu = \nu^*/(2p\nu^*+1)$ in turn is obtained for all values of (N, Q) with $Q = q^* + p(N-1)$.

We have considered in this work the following filling factors.

(1) $\nu = \frac{4}{11}$. Here, $\nu^* = 1 + \frac{1}{3}$. The parameters are $p = \bar{p} = n = \bar{n} = 1$, which gives

$$q^* = \frac{3N-8}{8}, \quad Q = \frac{11N-16}{8}. \quad (31)$$

(2) $\nu = \frac{5}{13}$. Here, $\nu^* = 1 + \frac{2}{3}$. The parameters are $p = \bar{p} = n = 1$ and $\bar{n} = -2$, which gives

$$q^* = \frac{3N-7}{10}, \quad Q = \frac{13N-17}{10}. \quad (32)$$

(3) $\nu = \frac{7}{19}$. Here, $\nu^* = 1 + \frac{2}{5}$. The parameters are $p = \bar{p} = n = 1$ and $\bar{n} = 2$, which gives

$$q^* = \frac{5N-17}{14}, \quad Q = \frac{19N-31}{14}. \quad (33)$$

(4) $\nu = \frac{6}{17}$. Here, $\nu^* = 1 + \frac{1}{5}$. The parameters are $p = n = \bar{n} = 1$ and $\bar{p} = 2$, which gives

$$q^* = \frac{5N-12}{12}, \quad Q = \frac{17N-24}{12}. \quad (34)$$

Of course, only integer values are allowed for N , $2q^*$, and $2Q$. The Table I explicitly lists the systems that we have studied below.

D. Matrix elements

The basis obtained in the way described above is not orthogonal for a given angular momentum sector L . We orthogonalize these using the Gram-Schmid procedure and then diagonalize the Coulomb Hamiltonian in the orthogonal basis. These require the knowledge of matrix elements of the type $\langle \phi_l | \phi_m \rangle$ and $\langle \phi_l | H | \phi_m \rangle$, where ϕ_l and ϕ_m ($l \neq m$) are unorthonormalized wave functions, which we obtain by Monte Carlo. Since the Monte Carlo evaluation is most efficient when the integrand is positive definite, we determine these using the equations^{16,17}

$$\langle \phi_l | \phi_m \rangle = \frac{\langle \phi_l + \phi_m | \phi_l + \phi_m \rangle - \langle \phi_l | \phi_l \rangle - \langle \phi_m | \phi_m \rangle}{2}, \quad (35)$$

and

TABLE I. The monopole strength Q as a function of N for the NQHE states studied in this work. The quantities ν and ν^* are the filling factors of electrons and composite fermions, with $\bar{\nu}$ being the CF filling factor in the partially filled level. N is the total number of composite fermions, and \bar{N} is the number of composite fermions in the partially filled level, at filling $\bar{\nu}$. Q and q^* are the monopole strengths for the electrons and composite fermions.

| ν | $\nu^* = n + \bar{\nu}$ | N | \bar{N} | q^* | Q |
|-------|-------------------------|-----|-----------|-------|------|
| 4/11 | 1+1/3 | 8 | 3 | 2 | 9 |
| | | 12 | 4 | 3.5 | 14.5 |
| | | 16 | 5 | 5 | 20 |
| | | 20 | 6 | 6.5 | 25.5 |
| | | 24 | 7 | 8 | 31 |
| 5/13 | 1+2/3 | 14 | 6 | 3.5 | 16.5 |
| | | 19 | 8 | 5 | 23 |
| | | 23 | 8 | 7 | 29 |
| 7/19 | 1+2/5 | 16 | 6 | 4.5 | 19.5 |
| | | 23 | 8 | 7 | 29 |
| 6/17 | 1+1/5 | 12 | 3 | 4 | 15 |
| | | 18 | 4 | 6.5 | 23.5 |
| | | 24 | 5 | 9 | 32 |

$$\begin{aligned} \langle \phi_l | V | \phi_m \rangle &= \frac{\langle \phi_l + \phi_m | V | \phi_l + \phi_m \rangle - \langle \phi_l | V | \phi_l \rangle - \langle \phi_m | V | \phi_m \rangle}{2}, \end{aligned} \quad (36)$$

where V denotes the Coulomb interaction Hamiltonian.

E. Orthogonalization

We denote $\{u_i\}$ as the unorthogonal but normalized basis set obtained from the set $\{\phi_i\}$, and define

$$u_{ij} \equiv \langle u_i | u_j \rangle = \frac{\langle \phi_i | \phi_j \rangle}{|\phi_i| |\phi_j|} \quad (37)$$

and

$$V_{ij} \equiv \langle u_i | V | u_j \rangle = \frac{\langle \phi_i | V | \phi_j \rangle}{|\phi_i| |\phi_j|}; \quad (38)$$

these are real numbers.

We then follow the Gram-Schmid procedure to construct an orthogonal basis set $\{\psi_i\}$ in terms of the unorthogonal basis set $\{u_i\}$. The former can be expressed as

$$\begin{aligned} \psi_j &= u_j - \sum_{i=1}^{j-1} \frac{1}{N_i^2} \langle \psi_i | u_j \rangle \psi_i, \\ &\equiv u_j - \sum_{i=1}^{j-1} f_{ij} \psi_i, \end{aligned} \quad (39)$$

with $N_i^2 = \langle \psi_i | \psi_i \rangle$ and $f_{ij} = \langle \psi_i | u_j \rangle / N_i^2$. While the above relation allows an iterative evaluation of $\{\psi_i\}$, we find it more convenient to work with the following expressions:

$$N_i^2 = \langle \psi_i | \psi_i \rangle = 1 - \sum_{k=1}^{i-1} f_{ki}^2 N_k^2 \quad (40)$$

and

$$\begin{aligned} f_{ij} &= \frac{\langle \psi_i | u_j \rangle}{N_i^2} = \frac{1}{N_i^2} \left[\left\langle u_i - \sum_{k=1}^{i-1} f_{ki} \psi_k \middle| u_j \right\rangle \right] \\ &= \frac{1}{N_i^2} \left[u_{ij} - \sum_{k=1}^{i-1} f_{ki} f_{kj} N_k^2 \right]. \end{aligned} \quad (41)$$

Equation (39) was used to obtain these expressions, as well as the fact that u_{ij} and f_{ij} are real. The Hamiltonian matrix elements

$$V_{ij} = \frac{\langle \psi_i | V | \psi_j \rangle}{N_i N_j} \quad (42)$$

in the basis set $\{\psi_i\}$ are thus obtained as

$$\begin{aligned} V_{ij} &= \frac{1}{N_i N_j} \left[V_{ij} - \sum_{k=1}^{j-1} f_{kj} E_{ik} N_i N_k \right. \\ &\quad \left. - \sum_{l=1}^{i-1} f_{li} \left[E_{lj} N_l N_j + \sum_{k=1}^{j-1} f_{kj} E_{lk} N_l N_k \right] \right], \end{aligned} \quad (43)$$

which are again obtained iteratively. We finally diagonalize the matrix V_{ij} to obtain the eigenvalue spectrum for a given L sector.

F. Computation

The major computation time is spent in calculating the matrix elements $\langle \phi_l | \phi_m \rangle$ and $\langle \phi_l | V | \phi_m \rangle$ in the Monte Carlo method, because at each step we must evaluate M Slater determinants, M being the size of the LECFB. To give an example, at $(N, Q) = (24, 31)$ we have $M = 1656$. To minimize the computational time, we sample all the states rela-

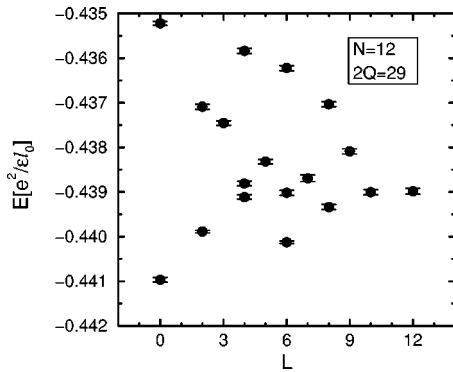

FIG. 3. The low-energy spectrum of interacting composite fermions at $(N, 2Q) = (12, 29)$, identified with $4/11$, where N is the number of composite fermions and $2Q$ is total flux penetrating the sample. The energies in this and subsequent figures are quoted in units of $e^2/\epsilon l_0$, where ϵ is the dielectric constant for the background material ($\epsilon \approx 13$ for GaAs) and $l_0 = \sqrt{\hbar c/eB}$ is the magnetic length at the relevant filling factor ($4/11$ in this case). Spherical geometry is employed for the calculation, and L is the orbital angular momentum of the state.

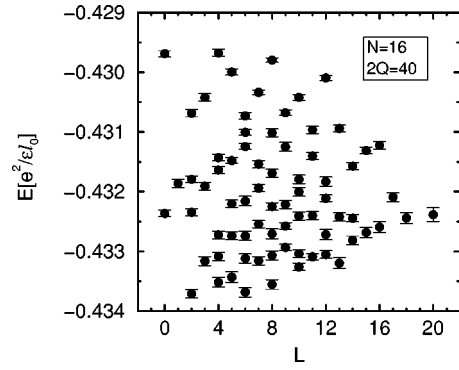

FIG. 4. The low-energy spectrum of interacting composite fermions at $(N, 2Q) = (16, 40)$, identified with $4/11$.

tive to the $L=0$ state which is obtained from the lowest energy state at ν^* . We typically perform six to ten Monte Carlo runs for each (N, Q) with $(0.6-1.0) \times 10^6$ Monte Carlo iterations in each run. For larger systems, we use parallel computers. (We divide all of the Monte Carlo steps into several configurations with each configuration placed on a single node of a Beowulf class PC cluster. One node consists of a dual 1 GHz Pentium III Processor. To obtain one data point, at a particular N , we use as many as 30 nodes repeatedly until the standard deviation in energies is sufficiently low to produce the desired accuracy.) Approximately 80 CPU days were needed for the calculation of the spectrum for $(N, Q) = (24, 31)$. The computation time increases very quickly with N , approximately as N^{12} .

It is difficult to ascertain how the statistical error in each element of the matrix would propagate into the eigenvalues. We instead obtain the spectrum in several different runs, and use the eigenvalues from those different runs to obtain the average and the standard deviation for each eigenvalue.

III. RESULTS AND DISCUSSION

We have considered the low-energy spectra at several values of $(N, 2Q)$ which were identified earlier with systems at special filling factors $4/11$, $5/13$, $7/19$, and $6/17$. Figures 3–6

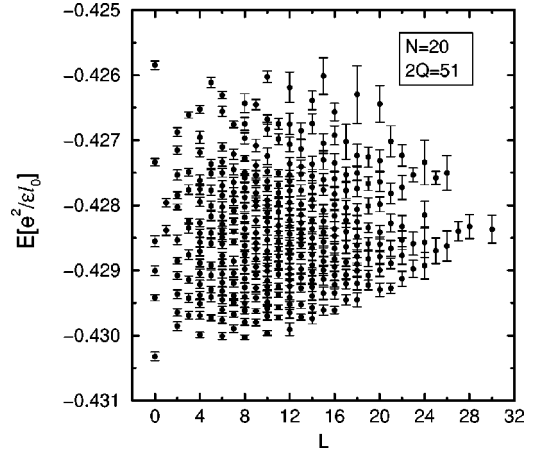

FIG. 5. The low-energy spectrum of interacting composite fermions at $(N, 2Q) = (20, 51)$, identified with $4/11$.

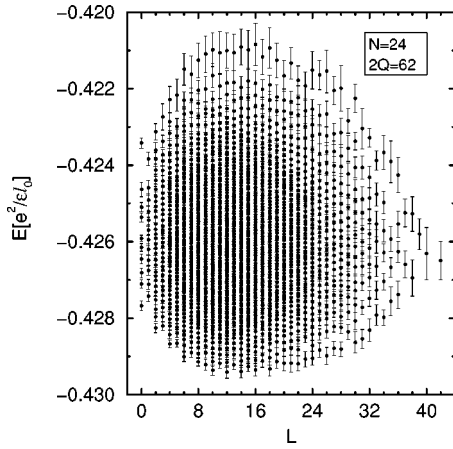

FIG. 6. The low-energy spectrum of interacting composite fermions at $(N, 2Q) = (24, 62)$, identified with $4/11$.

show results for $4/11$; Figs. 7 and 8 for $5/13$; Figs. 9 and 10 for $7/19$; and Figs. 11–13 for $6/17$. The energy spectra for $(8, 18)$ have been given in the past both from exact diagonalization and the composite-fermion theory.^{6,8,11} The accuracy of the energies is good enough to be able to state whether the ground state has $L=0$ or not. The error increases with increasing L , which is a consequence of our use of an $L=0$ state for importance sampling; in principle, the error at large L can be reduced by sampling with another reference state, but we do not see any need for it for the question of interest in this work.

The orthogonalization makes a qualitative difference in the spectrum. Figs. 14 and 15 show the energies of the basis states *prior* to orthogonalization, which ought to be compared to the spectra in Figs. 5 and 6, respectively.

The results explicitly confirm that our method indeed gives very low energy states. For example, consider $4/11$. The ground-state energy is approximately $-0.419e^2/\epsilon l_0$ per particle, which compares very favorably with $-0.420e^2/\epsilon l_0$, which is what one would get from a linear extrapolation between the energies⁷ at $1/3$ ($-0.410e^2/\epsilon l_0$) and $2/5$ ($-0.433e^2/\epsilon l_0$). Further, a large fraction of the states considered here are within an energy band less than the effective cyclotron gap at $1/3$, which is on the order of $0.1e^2/\epsilon l_0$. In other words, most of the states considered here

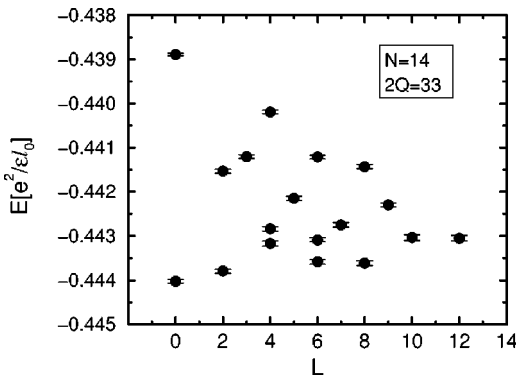

FIG. 7. The low-energy spectrum of interacting composite fermions at $(N, 2Q) = (14, 33)$, identified with $5/13$.

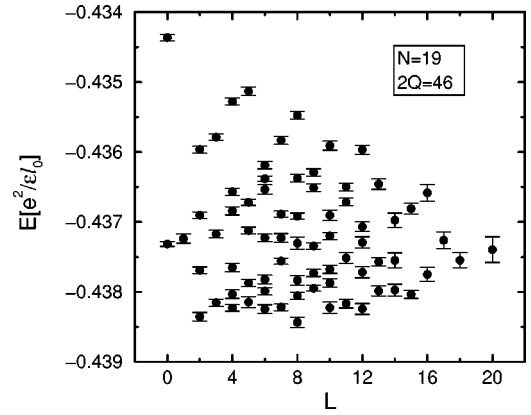

FIG. 8. The low-energy spectrum of interacting composite fermions at $(N, 2Q) = (19, 46)$, identified with $5/13$.

lie within the $1/3$ gap. This justifies our approximation of neglecting the states that involve transitions between composite-fermion Landau levels, which are expected to cost energy of order $0.1e^2/\epsilon l_0$.

Now we ask whether the spectra imply incompressibility. A characteristic feature of *all* incompressible states known to date is that they have an $L=0$ ground state, which is separated by a gap from other states; in addition, there is also a well-defined branch of neutral excitation. Furthermore, the ground state is extremely well described as a filled Landau level state of composite fermions, and the excitation as a particle-hole-pair excitation of composite fermion.^{6,8,18} This is the case, with no exception, for systems with (Q, N) related by $Q = (1 \pm 1/2n)N - (1 \pm n/2)$, which are identified with $\nu = n/(2n \pm 1)$.

None of the spectra have these standard features of an incompressible state. Even in cases when the ground states has $L=0$, there is no well-defined CF-exciton branch. The final spectrum at ν thus bears little resemblance to the spectrum at $\bar{\nu}$ that we started out with, implying that the interaction between composite fermions in the partially filled level is quite different from that of electrons at $\bar{\nu}$ in the lowest Landau level. The scenario described in the Introduction for NQHE is thus not borne out.

The ground states at the flux values considered above are,

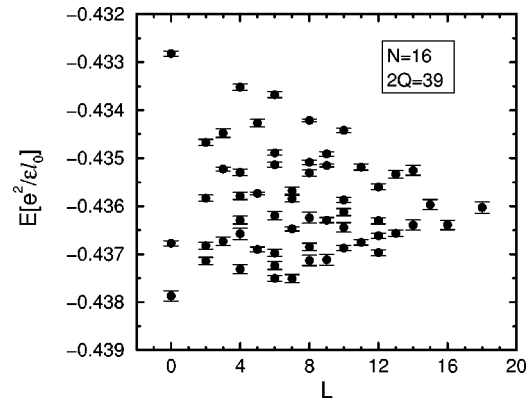

FIG. 9. The low-energy spectrum of interacting composite fermions at $(N, 2Q) = (16, 39)$, identified with $7/19$.

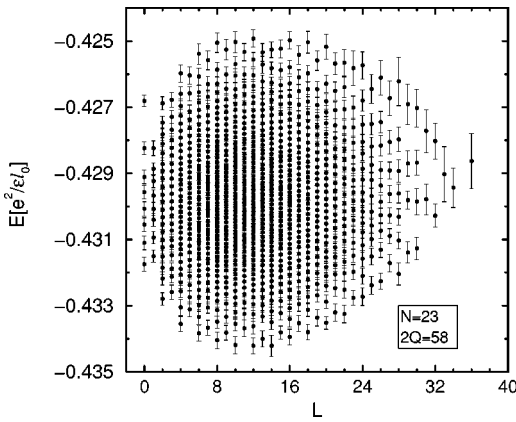

FIG. 10. The low-energy spectrum of interacting composite fermions at $(N,2Q)=(23,58)$, identified with 7/19.

in general, not incompressible uniform states with $L=0$. Consider 4/11 for example. It has been known^{6,8,11} that for $N=8$ particle system at $Q=9$, which is identified above with 4/11, the ground state does not have $L=0$. However, the system is effectively very small here, with only $\bar{N}=3$ composite fermions in the second level, and one may question if the conclusion will hold as N increases. We find that for $N=12$ and 20 the ground state has $L=0$, but for $N=16$ and 24 it does not. This provides an illustration for why a study of several values of N is crucial; if one had only studied $N=12$, that would have led one to exactly the opposite conclusion. Another example is the 12-particle system at 6/17, which has an $L=0$ ground state and might suggest FQHE at 6/17; however, the spectra for $N=18$ and 24 at 6/17 explicitly clarify that this is only a finite-size effect that does not survive in the thermodynamic limit.

Our study implies that even though the ground state sometimes has $L=0$, it does *not* describe an incompressible state at any of the filling factors considered here. The following observations support this statement.

(1) When the ground state has $L \neq 0$, the $L=0$ state is a rather highly excited state.

(2) In the plot of the ground-state energy with $1/N$, the energies of the $L=0$ ground states are not particularly low. See Fig. 16 for 4/11.

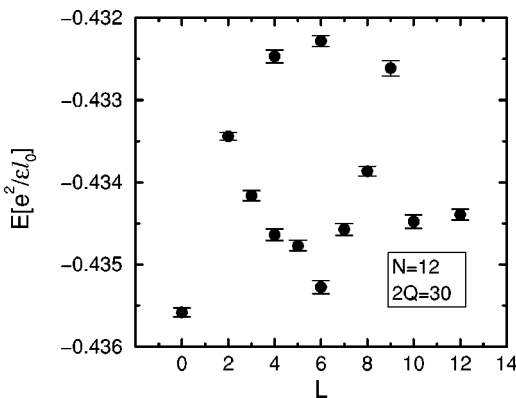

FIG. 11. The low-energy spectrum of interacting composite fermions at $(N,2Q)=(12,30)$, identified with 6/17.

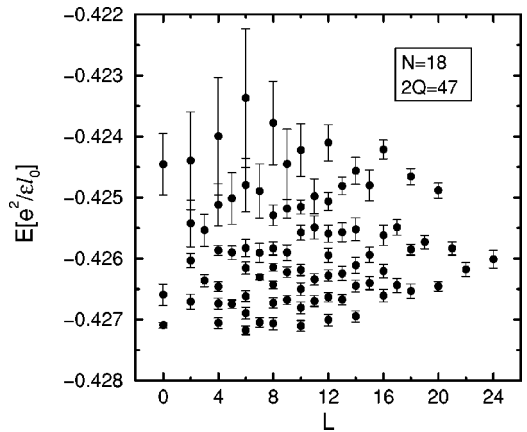

FIG. 12. The low energy spectrum of interacting composite fermions at $(N,2Q)=(18,47)$, identified with 6/17.

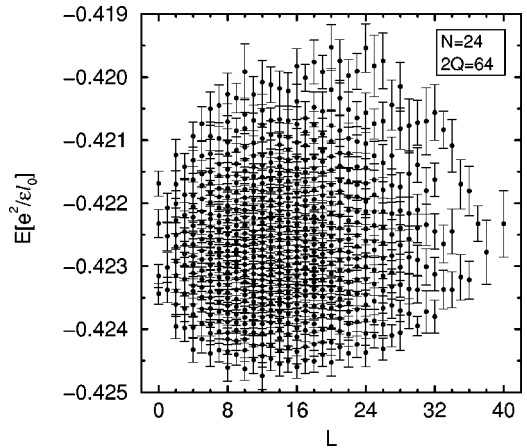

FIG. 13. The low-energy spectrum of interacting composite fermions at $(N,2Q)=(24,62)$, identified with 6/17.

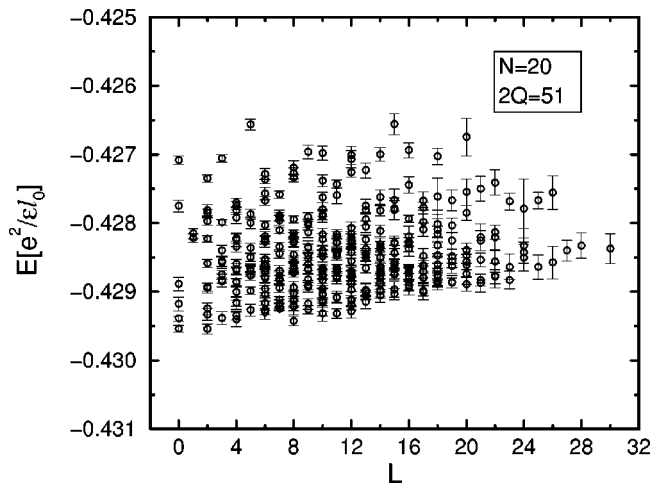

FIG. 14. The low-energy spectrum of composite fermions at $(N,2Q)=(20,51)$ prior to orthogonalization. The corresponding spectrum after orthogonalization is given in Fig. 5. The spectra shown here and in Fig. 5 are not physically meaningful, but are given here only to show the effect of orthogonalization.

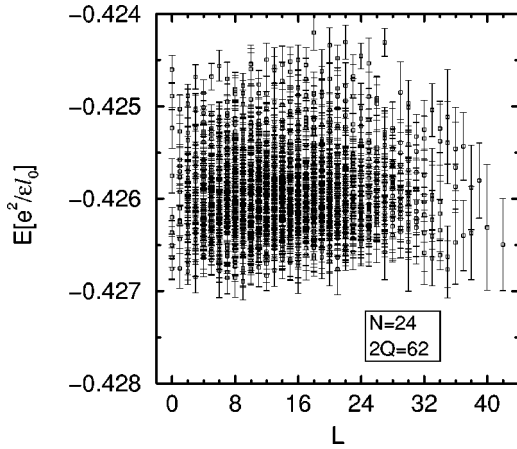

FIG. 15. The low-energy spectrum of composite fermions at $(N, 2Q) = (24, 62)$ prior to orthogonalization. It should be compared to the spectrum in Fig. 6.

(3) The ground state at $\bar{\nu}$ generally produces an excited state at ν , even in the $L=0$ sector (prior to orthogonalization), which indicates a breakdown of analogy between $\bar{\nu}$ and ν .

(4) The energy per particle is not a smooth function of $1/N$, but instead shows fluctuations characteristic of a compressible state. See Fig. 16.

(5) It is not inconceivable for a compressible state to have $L=0$, because a uniform state avoids Hartree energy cost, but it would be difficult to understand how an incompressible state might have $L \neq 0$.

As a result, the physical mechanism, in which some of the composite fermions turn into higher-order composite fermions and condense into Landau levels to exhibit QHE, does not appear to be relevant for fully spin-polarized electrons. The interaction between composite fermions in the second level is thus not of a form to produce NQHE. It must be stressed, however, that the results do *not* rule out NQHE through some hitherto unknown mechanism, which would imply a different relation between $2Q$ and N for a given filling factor than the one assumed above.

In Ref. 12, which also investigated some of the above fractions, it was predicted that the ground state is a bubble crystal of composite fermions, similar to what was found in Hartree-Fock studies of corresponding electronic states in higher Landau levels.¹⁹ Aside from several approximations, the results of that study were also predicated upon the quantitative validity of certain trial wave functions, making an

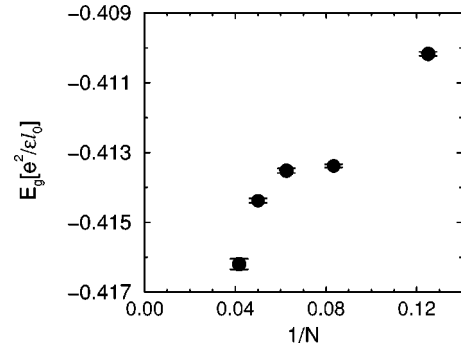

FIG. 16. The ground-state energy per particle as a function of $1/N$ for $4/11$. The energies plotted here have been multiplied by the factor $\sqrt{\rho_N/\rho}$, where ρ_N is the density of the finite system and ρ is the density in the thermodynamic limit, to account for the dependence of density on N . It ought to be noted that the ground state does not have $L=0$ in general.

independent confirmation worthwhile. Unfortunately, the spherical geometry used here is not convenient for the study of charge-density-wave states. We do note in passing that a crucial step in Ref. 12 was to model the states at $\nu = n + \bar{\nu}$ in terms of fermions at $\bar{\nu}$ with an effective two-body interaction. A close similarity between our Fig. 11 and Fig. 5 of Ref. 11, obtained from the two-body interaction model [both for $(N, 2Q) = (12, 30)$] provides support to the validity of this model.

In the end, we note that the above calculations assume a strictly two-dimensional system (with zero width), no disorder, and no mixing with higher electron Landau levels. These approximations represent an idealization of the actual experimental system. It is expected that the idealized model, while not accurate *quantitatively*, should give the correct qualitative behavior.

ACKNOWLEDGMENTS

It is a pleasure to acknowledge partial support by the National Science Foundation under Grant No. DMR-9986806. We are grateful to Horst Stormer, Wei Pan, and Chia-Chen Chang for valuable discussions, to David Weiss for suggesting the name “NQHE,” to the High Performance Computing (HPC) group led by V. Agarwala, J. Holmes, and J. Nucciarone, at the Penn State University ASET (Academic Services and Emerging Technologies) for assistance and computing time with the LION-XE cluster, and acknowledge Grant No. NSF DGE-9987589 for computer support.

¹K. von Klitzing, G. Dorda, and M. Pepper, Phys. Rev. Lett. **45**, 494 (1980).

²D.C. Tsui, H.L. Stormer, and A.C. Gossard, Phys. Rev. Lett. **48**, 1559 (1982).

³J.K. Jain, Phys. Rev. Lett. **63**, 199 (1989); Phys. Rev. B **41**, 7653 (1990); Phys. Today **53**(4), 39 (2000).

⁴V.J. Goldman, D.C. Tsui, and M. Shayegan, Phys. Rev. Lett. **61**,

881 (1988).

⁵W. Pan, H.L. Stormer, D.C. Tsui, L.N. Pfeiffer, K.W. Baldwin, and K.W. West, Phys. Rev. Lett. **88**, 176802 (2002).

⁶G. Dev and J.K. Jain, Phys. Rev. Lett. **69**, 2843 (1992).

⁷J.K. Jain and R.K. Kamilla, Int. J. Mod. Phys. B **11**, 2621 (1997); Phys. Rev. B **55**, R4895 (1997).

⁸J.K. Jain and R.K. Kamilla, in *Composite Fermions*, edited by

- Olle Heinonen (World Scientific, New York, 1998).
- ⁹J.K. Jain, Phys. Rev. B **40**, 8079 (1989); J.K. Jain and V.J. Goldman, *ibid.* **45**, 1255 (1992).
- ¹⁰W. Pan, H.L. Stormer, D.C. Tsui, L.N. Pfeiffer, K.W. Baldwin, and K.W. West (unpublished).
- ¹¹A. Wojs and J.J. Quinn, Phys. Rev. B **61**, 2846 (2000).
- ¹²S.-Y. Lee, V.W. Scarola, and J.K. Jain (unpublished).
- ¹³K. Park and J.K. Jain, Phys. Rev. B **62**, R13 274 (2000).
- ¹⁴We warn the reader that the assignment of filling factor to a finite system involves physical interpretation, and therefore must be treated with caution. The relation between N and $2Q$ at filling factor ν must have the form $N=2\nu Q+\alpha$, where α is of order unity, so as to produce the correct filling factor in the limit $N\rightarrow\infty$ ($\lim_{N\rightarrow\infty} N/2Q\rightarrow\nu$), but the value of α , which is crucial for finite systems, depends on the physics of the incompressible state. In this paper, the filling factor is attributed to a finite system assuming the familiar physics that has been successful in explaining the fractions $n/(2pn\pm 1)$. A different origin of incompressibility could possibly imply a different relation between N and $2Q$.
- ¹⁵T.T. Wu and C.N. Yang, Nucl. Phys. B **107**, 365 (1976).
- ¹⁶S.S. Mandal and J.K. Jain, Phys. Rev. B **63**, 201310(R) (2001); Solid State Commun. **118**, 503 (2001).
- ¹⁷V. Melik-Alaverdian and N. Bonesteel, Phys. Rev. B **52**, R17 032 (1995).
- ¹⁸V.W. Scarola, K. Park, and J.K. Jain, Phys. Rev. B **61**, 13 064 (2000).
- ¹⁹A.A. Koulakov, M.M. Fogler, and B.I. Shklovskii, Phys. Rev. Lett. **76**, 499 (1996).