

Superconductor-insulator transition in granular Pb films near a superconducting ground plane

S. R. Khan,* E. M. Pedersen, B. Kain, A. J. Jordan, and R. P. Barber, Jr.
Department of Physics, Santa Clara University, Santa Clara, California 95053
 (Received 25 August 1999)

We report observations of the zero-field superconductor-insulator transition in granular quench-condensed Pb for samples within 10–15 nm of relatively thick superconducting ground planes. Resistance vs temperature measurements of sufficiently thick Pb samples exhibit broadened superconductor transitions consistent with previous results on clean dielectric substrates. The lack of any measurable influence by the superconducting planes on the Pb film resistance is discussed within the context of zero-field vortex-antivortex unbinding explanations for the transition broadening.

The superconductor-insulator transition (SIT) has been a widely investigated phenomenon for more than two decades. This transition occurs in a variety of systems, and is a tool for probing fundamental properties of superconductors. A sensitive and controllable technique for studying SIT's uses quench-condensed films, prepared by evaporating superconductor materials onto cryogenically cooled substrates to produce metastable disorder.^{1–7} Incrementing the average film thickness^{1–6} or low-temperature annealing⁷ drives these samples from insulating (resistance increasing as temperature is lowered) to superconducting behavior (resistance dropping towards zero at low temperatures).

Quench condensation onto clean dielectric substrates produces granular films.^{1,2,6,7} These films typically have no measurable conductance until tens of atomic layers have been deposited, suggesting that material is clustering during the growth process. Scanning tunneling microscopy (STM) imaging of these films does show multiple layers of platelet-shaped grains.⁸ The resistance versus temperature curves, $R(T)$, for granular superconductor films have distinctive qualities. The thinnest films with measurable conductance show a marked increase in resistance as temperature is lowered below the bulk T_c of the material. At slightly larger thickness, the films exhibit a quasireentrant behavior where resistance first drops then increases below T_c . Even though these films are on the “insulating” side of the transition, changes near T_c give clear evidence that superconductivity is affecting the resistance even in the thinnest measurable samples. Tunneling into granular Pb films has shown that they consist of superconducting grains or clusters with a grain transition temperature T_{cg} and energy gap Δ_g near the bulk values for T_c and Δ even on the insulating side of the SIT.⁹ On the superconducting side of the SIT, granular films exhibit broadened superconductor transitions where the resistance of the film becomes immeasurably small at temperatures which can be well below T_{cg} . These transitions are the focus of this work.

It has been proposed that the broadened resistive transition in granular superconductors is an example of a Kosterlitz-Thouless-Berezinskii (KTB) transition.^{10–12} In an extension of the KTB theory,¹¹ thermally excited vortex-antivortex pairs provide a magnetic flux interaction with the film. A transition occurs at a critical temperature T_{KTB} above which vortex-antivortex pairs begin to unbind and contribute

a flux-flow resistance. Below T_{KTB} the vortices are bound in pairs and the measurable resistance drops to zero. Therefore, in granular films there are two critical temperatures, the first T_{cg} below which the grains are superconductors, and a somewhat lower T_{KTB} where the film resistance drops to zero. The resistive tails are the flux-flow region between T_{cg} and T_{KTB} . Experimental results have been supportive of this picture,¹² however, evidence that vortices are present is indirect.

This experiment is designed to test whether or not the vortices in the KTB model are present in the region of the broadened superconductor transitions. There must be equal numbers of vortices and antivortices since there is no external magnetic field applied to the sample. Since these vortices are thermal excitations, suppressing their ability to form will affect the resistive transition of the granular films if they are the mechanism that causes the broadening. This suppression should be accomplished by producing the granular quench-condensed films in proximity to a thick superconducting plane. Since each vortex or antivortex represents a flux quantum, these flux lines will necessarily pass through the nearby ground plane as long as the vortex pair separation is larger than the sample-to-ground-plane distance. Since any flux lines passing through the ground plane must then break Cooper pairs, they will be energetically less likely to form. Therefore, the formation of vortex-antivortex pairs should be suppressed by the presence of a superconducting ground plane, and sharpening of the resistive transitions would be observed in the granular film.

The ground plane was designed under several constraints. First, it is necessary that the granular sample be electrically isolated from the ground plane. Furthermore, the distance between the two should be smaller than the length scale for screening thermally excited vortices. However, no appreciable tunneling can be allowed between the sample and the ground plane. Such tunneling would provide an additional conduction path during transport measurements which would render them invalid. In short, the ground plane must be electromagnetically close while distant enough for no significant charge transfer. Finally, it is useful if the ground plane has a transition temperature T_{cgp} lower than T_{cg} . This requirement allows us to observe the broadened resistive transition as the ground plane becomes superconducting and the screening turns on. A signature of vortices would therefore

be a break or kink in the broadened resistive transition near T_{cgp} due to ground plane screening.

1 mm thick glass substrates are cleaned and fire polished before being prepared at room temperature with the superconducting ground plane. This ground plane consists of a sandwich of Ag/Pb/Al capped with Al_2O_3 . It was found that natural oxidation of the Al layer did not produce barriers of sufficient resistance. This result may be due to the multiple-layered ground plane structure since a simple Al film would be expected to oxidize more fully. In order to increase the oxide thickness, several additional 1–2 nm Al layers are deposited and allowed to oxidize. The final Al_2O_3 thickness is estimated to be 10–15 nm. The ground plane and sample layout are shown in Fig. 1(a). Figure 1(b) is a cross-sectional schematic of the sample layers with an approximate vertical length scale shown. In order to produce a ground plane with T_{cgp} less than that of the Pb grains ($T_{cg} \approx 7.2$ K), Ag is included for proximity effect reduction of T_{cgp} . Ag has the additional advantage that it forms continuous layers at much lower thicknesses than Pb when deposited onto a room-temperature dielectric. This metallic layer should also cause the Pb layer to wet more readily and therefore form a smoother film. It was found that Al deposited directly over the Ag films produces a wrinkled surface (presumably from film stress) which leads to shorts, so the Ag is deposited through a slightly smaller shadow mask than the Pb and Al overlayers. In order to measure T_{cgp} , the ground plane is cut in an hourglass shape to remove the Pb shunt around the central region. The ground planes in these experiments consist of approximately 10 nm of Ag, 45 nm of Pb, and 30 nm of Al. Varying the Ag/Pb ratio most strongly affects T_{cgp} with typical values ranging from 6.2 to 6.6 K.

After preparation of the ground plane, Ag contacts are evaporated as shown. Four are connected directly to the ground plane by scratching through the Al_2O_3 so that T_{cgp} and barrier resistance can be measured as the quench-condensed sample is incremented. The remaining six are reserved for connection to the quenched sample in the central 2.5 mm square region. Although only four leads are required for the measurement, six accommodate occasional lead failure. The substrate is backed with 1 mm thick Pb and mounted onto a Cu sample head. This Pb becomes superconducting at 7.2 K, below which it should screen out any appreciable stray magnetic field. Annealed Au wires are attached to the Ag contacts with conducting paint, and a shadow mask insulated with a thin sheet of mica is positioned to form the trapezoidal film as shown in Fig. 1. The layout of the mask prevents the film from crossing over a mesa edge to avoid shorts to the ground plane.

Room-temperature resistance measurements of the ground plane and contacts are used to confirm good electrical connections. Two-wire sample contact resistance measurements typically yield 10^7 – $10^9 \Omega$ at room temperature indicating good isolation from the ground plane, with four-wire ground plane resistances of the order 1 Ω . After good contacts are verified, the sample is enclosed in a stainless-steel chamber which is evacuated and submerged in liquid nitrogen for pre-cooling. The cryostat and all analog measurement electronics are enclosed in an earth-grounded shielded room to minimize electromagnetic interference. Once the sample is at equilibrium with the nitrogen bath, the contacts are measured again

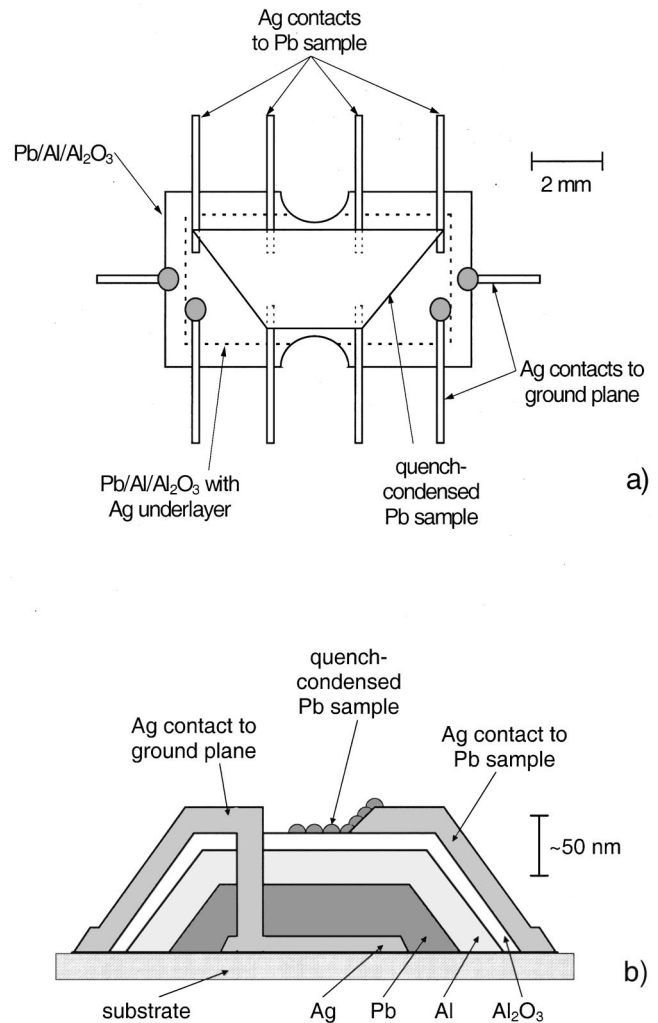

FIG. 1. (a) Sample layout showing the contacts for the four-wire ground plane measurement (terminated with circles) as well as the six leads connecting to the trapezoidal quench-condensed Pb sample (isolated from the ground plane). (b) Cross-sectional schematic of the ground plane and sample configuration.

with typical values of 10^8 – $>10^{10} \Omega$ (our limit of resistance measurement). Since the area of the sample is roughly 30 times that of the contacts over the ground plane, four-wire measurements of the quenched-condensed sample were rejected unless they were at least three orders of magnitude in resistance less than the two-wire contact resistance. This criterion should insure sample transport measurement errors due to parallel transport through the ground plane of less than 1 part in 30 for the very highest resistances (order $10^7 \Omega$), with negligible influence on the results within the region of most interest ($<10^5 \Omega$).

Substrates with good ground plane contacts and sufficiently isolated leads over the ground plane are cooled to 4.2 K. Since the evaporation chamber is submerged in liquid He, cryopumping produces ultrahigh vacuum conditions. Pb is deposited by thermal evaporation from a 0.25 mm W wire source, while the substrate is held at a temperature above T_{cg} to improve evaporation control near the onset of conduction. Measurable conductance is detected at average thicknesses comparable to those required for Pb evaporated onto clean insulating substrates (6–10 nm).^{2,6–8} After each deposition,

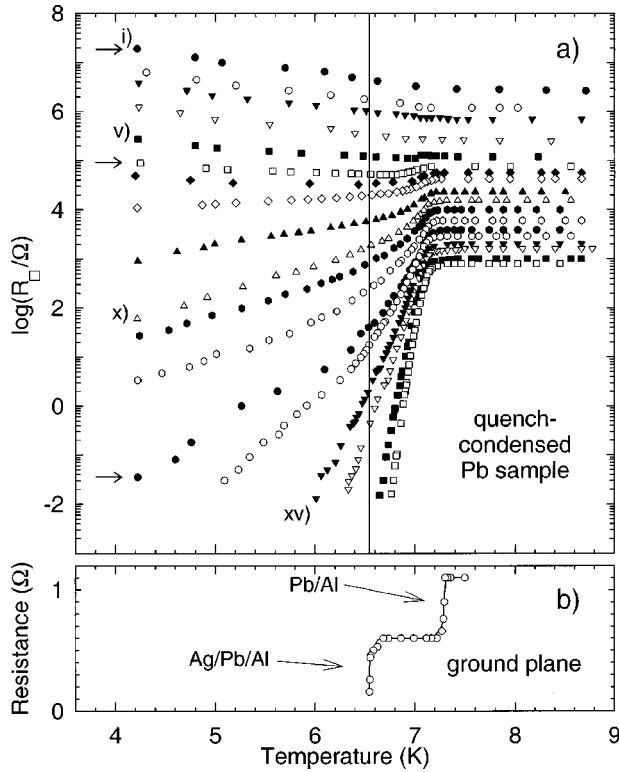

FIG. 2. Resistance per square vs temperature for a granular Pb film over a superconducting ground plane. (a) Curves i–xviii represent increasing thickness. The vertical line corresponds to $T_{cgp} = 6.55$ K (ground plane). Arrows mark three curves which are plotted on a linear scale in Fig. 3. (b) The resistive transition of the ground plane showing the Pb/Al transition of the ends and the Ag/Pb/Al transition of the midsection over which the quenched Pb sample is located. The solid curve represents data taken before quench-condensing the sample, and the circles are data recorded at the end of the entire experimental run.

$R(T)$ is measured between 4.2 and 10 K. Standard four-wire resistance measurements are derived from the linear regime of current-voltage (I - V) curves. All data are from these I - V curves, and curves with an apparent supercurrent (no discernible finite slope) or no clear linear regime are not assigned resistance values. Temperature is measured using a ruthenium-oxide resistance thermometer.

A typical data set is shown in Fig. 2 with $R(T)$ for the quench-condensed sample plotted on a logarithmic scale in order to include the roughly ten orders of magnitude of resistance that this experiment probes. Resistance measurement errors of about 5% are smaller than the symbols. Each successive evaporation (curves i–xviii) produces an $R(T)$ curve with lower resistance values. Three curves are marked with arrows and displayed on a linear scale in Fig. 3 using the same symbols as in Fig. 2. The ground plane transition is plotted linearly in Fig. 2(b). It appears as a double transition at about 7.2 K (Pb shunted ends) and then at $T_{cgp} = 6.55$ K (hourglass constriction).

The most remarkable feature of the data shown in Fig. 2 is the lack of any measurable effect in the sample below T_{cgp} (vertical line). These data are consistent with previous results for Pb-quenched onto clean dielectric substrates: the curves indicate insulating (i–vii) or superconducting behavior (xiii–xviii) as temperature is lowered.^{1,2,6–9,13} Curves that do not

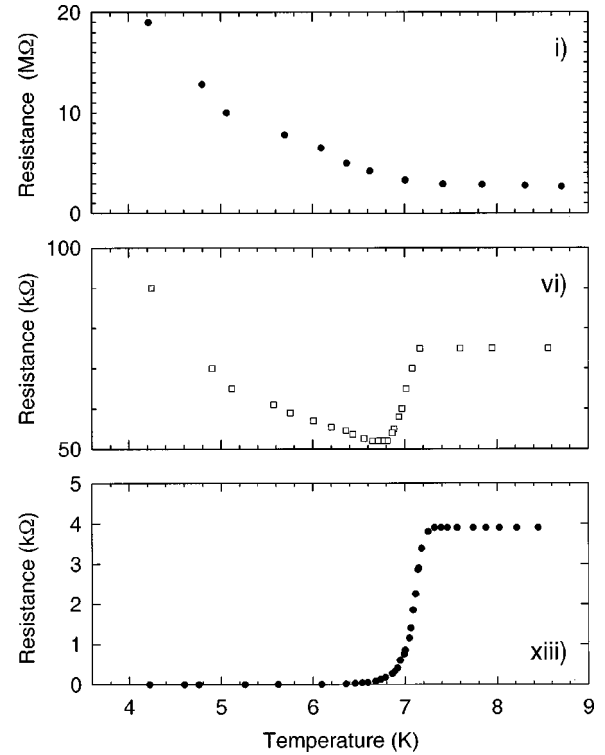

FIG. 3. Linear plots of three selected curves from Fig. 2. Resistance changes occur below about 7.2 K in each case indicating “granular” films with a well defined T_{cg} near the bulk value.

fit clearly into either category (viii–xii) have what appear to be broadened tails, and previous results to 100 mK suggest that most of these traces would eventually lose measurable resistance at lower temperatures.¹³ It is important to note that during these experiments, no metallic samples (resistance approaching a constant at low temperature) were observed in the temperature range above 4.2 K. For our purposes lower temperatures were not accessed since the region of interest is near T_{cgp} . The nature of the $R(T)$ curves in Fig. 2 indicates that the sample is granular even over the ground plane, and the clear resistance changes which are apparent in Fig. 3 near 7.2 K also support this conclusion.

Focusing attention on the temperature region near T_{cgp} , the measurements of sample i of over $10^7 \Omega$ indicate good isolation between the sample and the ground plane. The overall appearance of the $R(T)$ curves is consistent with previous results. In particular, there appears to be no significant effect on the broadened resistive tails. It is expected that vortex suppression would lead to sharper transitions beginning near T_{cgp} , so we conclude that either thermally excited vortices are not the dominant mechanism controlling the resistive transition or this configuration is not suppressing them. It is also important to note that since these films support nearly bulk values of T_{cg} and Δ_g , we expect small or no measurable effects due to screening of the Coulomb interaction by the nearby ground plane as has been observed in ultrathin Bi samples.¹⁴

Granular superconductor films have been cited as candidates for a vortex unbinding transition.^{11–12} At thicknesses near the onset of conduction, structural voids are observed in STM images⁸ and supported by experiments in an applied field which show no appreciable vortex core presence.^{6,9} For

Pb films, vortex cores are not observed until the sheet resistance is lowered to 375Ω .⁶ With typical sample resistances in the $k\Omega$ range, this result suggests that flux lines due to applied fields penetrate the sample where there is no material and thermally excited vortices would therefore require much less energy per excitation. Another result that suggests vortices might play an important role is the strong magnetoresistance of these samples at low fields.^{2,13} Measurable increases in resistance within the broadened transitions have been observed at 0.01 G ,¹³ so even small populations of vortices might produce a measurable resistance.

The KTB transition in superconductors is characterized by vortex-antivortex pairs that exist over a large range of length scales due to interaction energies that depend logarithmically on their separation. Unbinding occurs for pairs at a length scale ξ_+ , the vortex correlation length.^{10,11} In order to evaluate the effectiveness with which our configuration should suppress these vortices, it is useful to consider the $10\text{--}15 \text{ nm}$ separation between the sample and the ground plane in comparison to ξ_+ . STM imaging of quench-condensed granular Pb films shows grains of about 20 nm diameter.⁸ The *smallest* vortex pairs should be of that order or larger, since penetration of a superconducting grain would be energetically unfavorable. At this scale, the vortices are perhaps only weakly affected by the ground plane. However, it is not necessary to suppress formation of the smallest pairs, only a significant fraction of those that are unbinding. Furthermore, ξ_+ increases as temperature is lowered and diverges at T_{KTB} , so we expect that the effectiveness of the ground plane's magnetic screening should *increase* as temperature is lowered. We, therefore, have confidence that a sizable portion of vortices should be suppressed using this configuration. Since there is no noticeable change in the broadened transitions, we conclude that vortices are not the dominant mechanism in this regime.

It is possible to understand the SIT in granular samples within the simple framework of the superconductor pair wave function, $\Psi_s \approx \Delta^{1/2} e^{i\phi}$ with amplitude $\Delta^{1/2}$ and phase ϕ . Ψ_s can be destroyed either by breaking of long-range phase coherence¹⁻³ or suppression of the amplitude.^{4,5} The presence of nearly bulk values for T_{cg} and Δ_g even on the insulating side of the SIT indicates that the transport in granular films is dominated by intergrain tunneling and the stability of the phase between grains or clusters of grains. The broadened transitions in these samples is explained as phase breaking between grains or clusters of grains due to thermal fluctuations. Lowering temperature to reduce these fluctuations (or equivalently increasing the connectivity of the sample by deposition of additional material) can increase the phase coherence until at sufficiently low temperatures, global phase coherence is established and a zero resistance is observed. As a result of our measurements, we favor this explanation without the inclusion of vortices.

Our observations of the zero-field superconductor-insulator transition in granular Pb samples near a superconducting plane do not indicate the presence of vortices. Although vortex excitations may play some role locally in the film, they do not appear to be a dominant phase-breaking mechanism in this system.

We gratefully acknowledge equipment from R. Glover; valuable discussions with R. Dynes, R. Glover, J. Valles, P. Xiong, F. Sharifi, L. Merchant, P. Kesten, D. Jackson, and W. DeHart; work by T. Mahatdejkul and A. Vo; and the invaluable technical support of S. Tharaud. This work was funded by a Research Corporation Cottrell College Science Grant, Santa Clara University IBM Faculty Research Grants, a Paul Locatelli Junior Faculty Grant, and an SCU College of Arts and Sciences Intellectual Community Grant.

*Present address: Dept. of Physics, University of Florida, Gainesville, FL 32611.

¹R. C. Dynes, J. P. Garno, and J. M. Rowell, Phys. Rev. Lett. **40**, 479 (1978).

²H. M. Jaeger, D. B. Haviland, B. G. Orr, and A. M. Goldman, Phys. Rev. B **40**, 182 (1989), and references within.

³R. C. Dynes, A. E. White, J. M. Graybeal, and J. P. Garno, Phys. Rev. Lett. **57**, 2195 (1986).

⁴D. B. Haviland, Y. Liu, and A. M. Goldman, Phys. Rev. Lett. **62**, 2180 (1989).

⁵J. M. Valles, Jr., R. C. Dynes, and J. P. Garno, Phys. Rev. Lett. **69**, 3567 (1992).

⁶S. Y. Hsu and J. M. Valles, Jr., Phys. Rev. B **49**, 6416 (1994).

⁷R. Barber, Jr. and R. E. Glover, III, Phys. Rev. B **42**, 6754 (1990).

⁸K. L. Ekinci and J. M. Valles, Jr., Phys. Rev. Lett. **82**, 1518 (1999).

⁹R. P. Barber, Jr., L. M. Merchant, A. La Porta, and R. C. Dynes, Phys. Rev. B **49**, 3409 (1994).

¹⁰J. M. Kosterlitz and J. D. Thouless, J. Phys. C **6**, 1181 (1973); V. L. Berezinskii, Zh. Eksp. Teor. Fiz. **61**, 1144 (1971) [Sov. Phys. JETP **34**, 610 (1971)]. For a review see P. Minnhagen, Rev. Mod. Phys. **59**, 1001 (1987).

¹¹M. R. Beasley, J. E. Mooij, and T. P. Orlando, Phys. Rev. Lett. **42**, 1165 (1979); B. I. Halperin and D. R. Nelson, J. Low Temp. Phys. **36**, 599 (1979); A. M. Kadin, K. Epstein, and A. M. Goldman, Phys. Rev. B **27**, 6691 (1983).

¹²A. F. Hebard and A. T. Fiory, Phys. Rev. Lett. **44**, 291 (1980); P. A. Bancel and K. E. Gray, *ibid.* **46**, 148 (1981); S. A. Wolf, D. U. Gubser, W. W. Fuller, J. C. Garland, and R. S. Newrock, *ibid.* **47**, 1071 (1981); A. F. Hebard and A. T. Fiory, *ibid.* **50**, 1603 (1983); J. Schmidt, M. Levy, and A. F. Hebard, Phys. Rev. B **50**, 3988 (1994).

¹³R. P. Barber, Jr. and R. C. Dynes, Phys. Rev. B **48**, 10 618 (1993).

¹⁴E. G. Astrakharchik and C. J. Adkins, J. Phys.: Condens. Matter **10**, 4509 (1998).