

Adiabatic transport of Cooper pairs in arrays of Josephson junctions

J. P. Pekola, J. J. Toppari, M. Aunola, and M. T. Savolainen
Department of Physics, University of Jyväskylä, P.O. Box 35, 40351 Jyväskylä, Finland

D. V. Averin
Department of Physics, Harvard University, Cambridge, Massachusetts 02138
and Department of Physics and Astronomy, SUNY at Stony Brook, Stony Brook, New York 11794
 (Received 16 June 1999)

We have developed a quantitative theory of Cooper pair pumping in gated one-dimensional arrays of Josephson junctions. The pumping accuracy is limited by quantum tunneling of Cooper pairs out of the propagating potential well and by direct supercurrent flow through the array. Both corrections decrease exponentially with the number N of junctions in the array, but give a serious limitation of accuracy for any practical array. The supercurrent at resonant gate voltages decreases with N only as $\sin(\varphi/N)/N$, where φ is the Josephson phase difference across the array. [S0163-1829(99)51138-7]

When a potential well propagates adiabatically along an electron system that is effectively one-dimensional, it carries with it additional electron density, and induces dc electric current through the system. Such a pumping effect is observed in mesoscopic systems ranging from small metallic tunnel junctions in the Coulomb blockade regime,¹⁻³ to semiconductor quantum dots,⁴ and to one-dimensional ballistic channels.⁵ The propagation of potential well is arranged either directly through the propagation of real acoustoelectric wave^{2,5} or by phase-shifted gate voltages.^{1,3,4} Particular interest is attracted to the pumping regime when the potential well carries a quantized number m of electrons so that the induced current I is related to the frequency f , with which the well crosses the system, by the fundamental relation $I = mef$. The well for precisely m electrons can be created either by the Coulomb interaction, as, for instance, in the Coulomb blockade pumps,¹⁻³ or can be simply due to the discrete nature of single-particle states inside the well.^{6,7} In the case of Coulomb blockade pumps, precision of the pumped charge quantization is reaching the level sufficient for metrological applications.³ Different sources of inaccuracy in the pumps have been discussed in Refs. 8-11,3.

Until presently, the pumping effect was studied mostly in normal systems, where transport is due to individual electrons. A timely motivation for studying Cooper pair transfer comes from quantum computation, where pumping can play an important role as an essential element of dynamics of quantum logic gates.¹² The aim of this work is to develop a quantitative theory of pumping of Cooper pairs in one-dimensional arrays of superconducting tunnel junctions. In particular, we find fundamental corrections to the quantized pumping regime and show that they are unexpectedly large in arrays with a small number of junctions. These large quantum corrections can also explain the fact that the first (and so far the only) experiment with pumping of Cooper pairs¹³ has failed to demonstrate accurate pumping.

First we derive the general expression for the charge transferred through an array of N superconducting tunnel junctions in the Coulomb blockade regime by adiabatic pumping of Cooper pairs. In the standard model such arrays

are characterized by two energies, their charging energy H_C as a system of capacitors, and their energy associated with tunneling.¹⁴ We assume that the characteristic energy E_C of a Cooper pair in the array and the temperature ($k_B T$) are both much lower than the superconducting energy gap of the electrodes. The first one replaces the usual condition in the normal Coulomb blockade where the junction resistances should be larger than the quantum resistance. With these conditions fulfilled quasiparticle tunneling is exponentially suppressed, while the tunneling energy of Cooper pairs in junction i reduces to a constant-tunneling amplitude $E_{Ji}/2$. (E_{Ji} is also called Josephson coupling energy.) In this work, the bias voltage is set to be zero, and thus a constant Josephson phase difference φ is fixed across the array. We can then treat the two external electrodes of the array as one, so that effectively the array forms a loop and φ plays the role of external flux threading it. Then, the Hamiltonian of the N pump is:

$$H = H_C(n - q) - \sum_{k=1}^N \frac{E_{Jk}}{2} (|n\rangle \langle n + \delta_k| e^{i\varphi/N} + \text{H.c.}). \quad (1)$$

Here $n \equiv \{n_1, n_2, \dots, n_{N-1}\}$ and $q \equiv \{q_1, q_2, \dots, q_{N-1}\}$ represent, respectively, the number n_i of Cooper pairs on each island of the array, and q_i , normalized by $2e$, the charge injected to each island by the gate voltage V_{gi} (see Fig. 1). The term δ_k describes the change of n due to tunneling of one Cooper pair in the k th junction. We will also need the operator of the current in the k th junction:

$$I_k = \frac{ieE_{Jk}}{2\hbar} (|n\rangle \langle n + \delta_k| e^{i\varphi/N} - \text{H.c.}). \quad (2)$$

Equations (1) and (2) are written in a form which shows explicitly the contribution φ/N to the phase φ_j across each of the junctions in the array from the phase φ fixed across the whole array. It should be stressed, however, that in the limit of small tunnel amplitudes E_{Jk} considered in this work, the states of the array are characterized by the well-defined distribution of charges, and the actual phases φ_j are completely undetermined due to large quantum fluctuations.

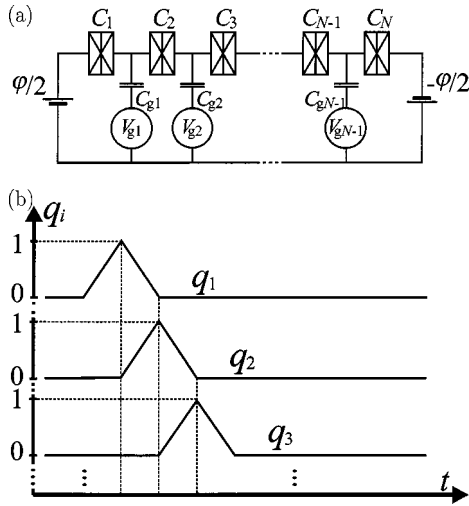

FIG. 1. (a) A schematic drawing of a gated Josephson array of N junctions. In pumping Cooper pairs, gate voltages V_{gi} are operated cyclically. C_i are the capacitances of the junctions, and C_{gi} are gate capacitances. In a uniform pump $C_i \equiv C$ for all $i = 1, 2, \dots, N$. (b) A train of gate voltages to carry a charge in a pump. Here $q_i = -C_{gi}V_{gi}/2e$.

There are two mechanisms of Cooper pair transport in the array. One is the direct supercurrent through the whole array, another is pumping, the charge transfer in response to adiabatic variation of the injected charges q . To derive the general expression for the total charge Q transferred during one pumping period, we introduce the basis of instantaneous eigenstates $|m\rangle$ of the array for a given q . These are exact eigenstates if q is stationary. When q varies, there is a correction $|\delta m\rangle$ to state $|m\rangle$ of the form

$$|\delta m\rangle = i\hbar \sum_{l \neq m} \frac{|l\rangle \langle l | \nabla_q m \rangle}{\varepsilon_l - \varepsilon_m} \dot{q}, \quad (3)$$

where $\varepsilon_{l,m}$ are the eigenenergies of states $|l,m\rangle$. Thus the average current $\langle I_k \rangle$ in the k th junction is different from the dc supercurrent $\langle m | I_k | m \rangle$ in the state $|m\rangle$, $\langle I_k \rangle = \langle m | I_k | m \rangle + 2 \operatorname{Re} \langle m | I_k | \delta m \rangle$. Integrating over the pumping period τ we obtain the charge Q , in units of $2e$, transported through the array:

$$Q = \frac{1}{\hbar} \frac{\partial}{\partial \varphi} \int_0^\tau dt \varepsilon_m[q(t)] + 2 \operatorname{Re} \oint \langle m | Q_k | dm \rangle. \quad (4)$$

Here we used the standard thermodynamic argument that the supercurrent in the state $|m\rangle$ can be expressed as $(2e/\hbar) \partial \varepsilon_m / \partial \varphi$, and defined the operator of the normalized charge transferred in the k th junction, $Q_k = (1/2e) \int dt I_k(t)$:

$$\langle m | Q_k | l \rangle = \frac{i\hbar}{2e} \frac{\langle m | I_k | l \rangle}{\varepsilon_l - \varepsilon_m}. \quad (5)$$

Diagonal matrix elements of Q_k are not defined by Eq. (5), but they do not contribute to Q .

Few remarks should be made concerning Eq. (4). Since the state of the array at the end of the cycle is exactly the same as in the beginning, charge conservation implies that Q is independent of the index k of the junction which is used in calculating Q . It is, however, a function of the array state

$|m\rangle$. We did not include energy relaxation in the model and pumping is in principle possible even when $|m\rangle$ is an excited state, the case not considered here. The last remark is that Eq. (4) shows that there is a close connection between the transferred charge Q and quantum-mechanical phase of the state $|m\rangle$ accumulated during the cycle. Supercurrent contribution to Q is directly related to the dynamic part of the phase, $\int_0^\tau dt \varepsilon_m[q(t)]/\hbar$, while the pumped charge is associated with the Berry's phase $\xi = i\oint \langle m | dm \rangle$.¹⁵

In the following quantitative analysis, the array is assumed to be uniform. The charging energy of the array is then

$$E_C = \frac{E_C}{N} \left[\sum_{k=1}^{N-1} k(N-k)u_k^2 + 2 \sum_{l=2}^{N-1} \sum_{k=1}^{l-1} k(N-l)u_k u_l \right], \quad (6)$$

where $E_C \equiv (2e)^2/2C$, C is the common capacitance of each junction in the array, and $u_k \equiv n_k - q_k$. In the regime of accurate pumping the main contribution to Q comes from the second term in Eq. (4) while the supercurrent gives only small corrections limiting the pumping accuracy. The necessary condition for this regime to exist is $E_J \ll E_C$, which we assume from now on. As in the case of Berry's phase, the second term in Eq. (4) does not vanish because the integration contour encloses the singularity where the energies of several charge states coincide. This degeneracy occurs when $q_k = 1/N$ for all k . For such q , the array dynamics reduces to that of a particle on the N sites with equal energies forming a loop. The N eigenstates of such a particle are plane waves with energies $\varepsilon_k = -E_J \cos[(\varphi - 2\pi k)/N]$, $k = 0, 1, \dots, N-1$, and the equilibrium supercurrent $I(\varphi)$ through the array is

$$I(\varphi) = \frac{I_c}{N} \sin \frac{\varphi}{N}, \quad \varphi \in [-\pi, \pi]. \quad (7)$$

Here, $I_c = 2eE_J/\hbar$ is the critical current of one junction. Relation (7) should be continued periodically in φ beyond the interval $[-\pi, \pi]$, and $I(\varphi)$ exhibits cusps at $\varphi = \pm\pi$. It also shows that the supercurrent decreases only as N^{-2} at large N .

Large supercurrent (7) at resonant q means that the trajectory in q space for accurate pumping should circle the degeneracy point sufficiently far away from it. It then successively brings in resonance the pairs of states that correspond to a Cooper pair occupying two neighboring islands of the array [as illustrated in Fig. 2(a) for $N=3$]. If this process is slow, the Cooper pair is transported adiabatically between the islands by the usual two-state level-crossing transitions that shift it along the array following the gate voltages. One Cooper pair is then transported through the array per cycle corresponding to a q -space trajectory circling once around the degeneracy point. One condition necessary for accurate pumping is that the probability of the Landau-Zener transitions to the excited states is negligible and the array remains in the minimum-energy state throughout the cycle. This condition limits the rate of pumping, $1/\tau$, by the Josephson coupling energy, $\hbar/\tau \ll E_J$. However, even then, i.e., in the regime of the present work, the pumping is not accurate due to the nonvanishing E_J/E_C .

The gate voltages in an N pump are typically^{1,3} sequences of triangular pulses shown in Fig. 1(b). The array is then

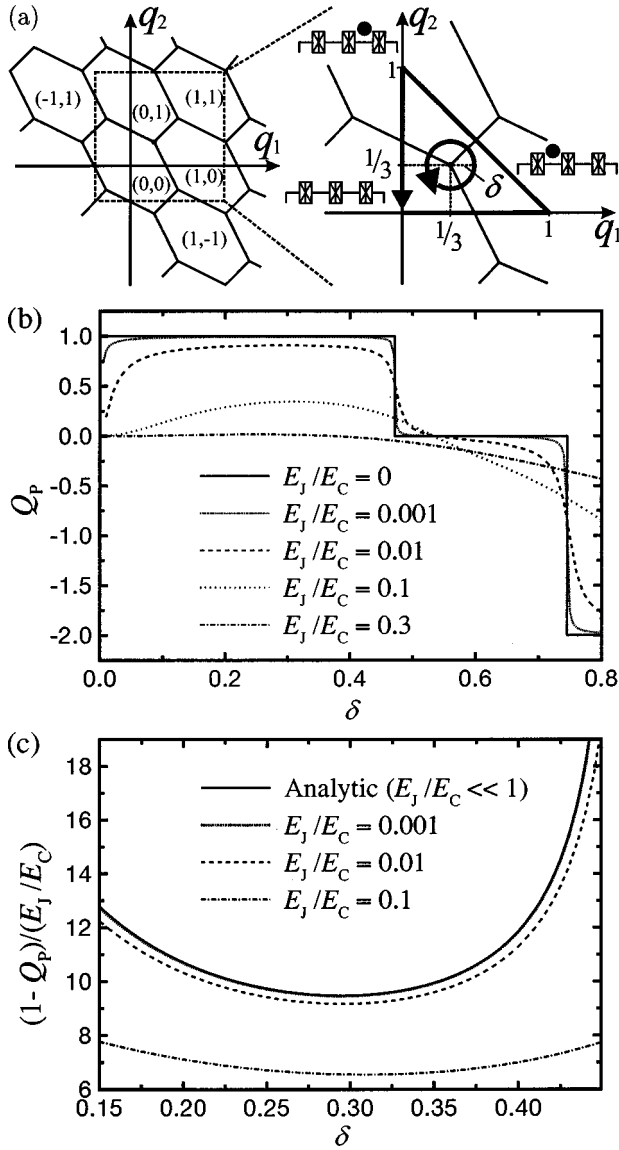

FIG. 2. (a) The states with minimum charging energy of the uniform $N=3$ pump on the (q_1, q_2) plane. The vector (n_1, n_2) denotes the stable configuration inside each hexagon. A circular path with radius δ , and the triangular path of Fig. 1(b) are shown. Only states contributing to the inaccuracy in charge transport in the leading order have been shown. (b) and (c) Numerical results of quantum inaccuracy of a uniform 3 pump for different values of E_J/E_C . The analytical result of Eq. (11), exact in the limit of small E_J/E_C , is shown by a solid line in (c).

completely translationally invariant. The pumping cycle with triangular gates can be divided into N steps with Cooper pair transported through one junction at each step. Instead of calculating the charge pumped in one junction during the whole cycle, Q_P , we can equivalently sum up the charges Q_j transferred in all junctions during one step of pumping:

$$Q_P \equiv 2 \operatorname{Re} \oint \langle m | Q_k | dm \rangle = \sum_{j=1}^N Q_j. \quad (8)$$

Introducing variations $\delta \langle n_j \rangle$ of the average number of Cooper pairs on each island during one step, we can express the charge conservation [which follows from the Hamiltonian (1) as $\delta \langle n_j \rangle = Q_j - Q_{j+1}$]. Translational invariance implies

TABLE I. Comparison between the numerically (top) and perturbatively (bottom) obtained transport inaccuracies ($\varphi=0$) for uniform Cooper pair pumps with $N=3, 5$, or 7 junctions and few values of E_J/E_C .

E_J/E_C	$N=3$	$N=5$	$N=7$
0.01	0.0872	5.20×10^{-5}	
	0.0900	5.21×10^{-5}	1.84×10^{-8}
0.03	0.245	1.39×10^{-3}	4.40×10^{-6}
	0.270	1.41×10^{-3}	4.47×10^{-6}
0.1	0.634	4.63×10^{-2}	1.60×10^{-3}
	0.900	5.21×10^{-2}	1.84×10^{-3}

that the distribution $\langle n_j \rangle$ is just shifted by one island during the step, $\delta \langle n_j \rangle = \langle n_{j-1} \rangle - \langle n_j \rangle$. For triangular gates we have precisely one Cooper pair in the array, $\sum_{j=1}^N \langle n_j \rangle = 1$, and we then obtain $\sum_{j=1}^N Q_j = 1 + N(Q_N - \langle n_N \rangle)$. Here the index N and the adjacent junction are arbitrary. If we chose N such that the island is furthest away from the junction where the Cooper pair is tunneling, we can neglect the occupation of the island in this equation and obtain:

$$Q_P = 1 + N Q_N. \quad (9)$$

Now we can use Eqs. (4) and (5) to calculate the charge Q_N transferred during one pumping step through the junction that is most distant from the tunneling Cooper pair. Because of the energy difference in the denominator of Eq. (5), the main contribution to Q_P arises at the resonances when a Cooper pair is transferred between the two islands. In this situation, there are two lowest-energy states with energy separation on the order of E_J , and we can keep only the matrix elements of current between these two states in Eq. (5). At the two islands, where the Cooper pair is transferred, the resonant states are given by the usual expressions of the two state systems. To get a nonvanishing matrix element of the current in the N th junction, we must “extend” the wave functions of the resonant states from the two islands occupied by the Cooper pair to this junction. We obtain by perturbation theory in E_J and by Eqs. (4) and (5)

$$Q_P = 1 - \frac{N^{N-1}(N-1)}{(N-2)!} \left(\frac{E_J}{2E_C} \right)^{N-2} \cos \varphi. \quad (10)$$

Thus the probability of Cooper pair tunneling limiting the pumping accuracy decreases roughly as $(E_J/E_C)^{N-2}$ with increasing N . It is physically clear that this conclusion should remain valid for nonuniform arrays also. Results of both numerical [from Eqs. (4) and (5)] and perturbative [Eq. (10)] calculations are shown in Table I.

For $N=3$, triangular gate voltages correspond to the triangular pumping trajectory on the (q_1, q_2) plane shown in Fig. 2. Another pumping method in the $N=3$ pump^{1,13} uses harmonic gate voltages, corresponding to a circular trajectory around the degeneracy point $q_1 = q_2 = 1/3$. It is possible to calculate the pumped charge directly from Eqs. (4) and (5). For $\varphi=0$ we obtain

$$Q_P = 1 - \frac{3}{2} \left(\frac{1}{3\sqrt{2}\delta} + \frac{1}{2-3\sqrt{2}\delta} + \frac{1}{\frac{3}{\sqrt{5}}\delta} + \frac{1}{1-\frac{3}{\sqrt{5}}\delta} \right) \frac{E_J}{E_C}, \quad (11)$$

where $\delta \equiv [(q_1 - 1/3)^2 + (q_2 - 1/3)^2]^{1/2}$ is the radius of the trajectory. The results of Eqs. (11) and (10) for $N=3$ almost coincide for the optimum radius of $\delta \approx 0.3$. It should be noted that the quantum inaccuracy in pumping is very significant: it is more than 20% at $E_J/E_C = 0.03$, which is a very small value. (Practically, E_J is limited from below by temperature, while the maximum E_C is limited by the minimum feature size in fabrication.) The accurate coherent pumping is thus practically impossible in the $N=3$ pumps. Figure 2 shows Q_P calculated numerically from Eq. (4) for $\varphi=0$ (no direct supercurrent present) as a function of δ . For small radii the charge is quadratic in δ , $Q_P/\pi\delta^2 = (8E_C/27E_J)^2$, as can be derived from Eq. (4). At large δ 's the pumped charge in Fig. 2 starts to decrease since the trajectory approaches another degeneracy point at $q_1 = q_2 = 2/3$.

Finally, we consider the supercurrent in the regime of accurate pumping. In this regime, the current is largest during the Cooper pair transition between a pair of islands of the array. The effective tunneling amplitude of this transition consists of two parts: the direct transition between the islands through one junction separating them, and the transition through the rest of the $N-1$ junctions. Interference between

these two processes determines the phase-dependent part of the Cooper pair energy. We obtain the supercurrent of $(N-1)$ junction tunneling by the standard perturbation theory:

$$I(\varphi) = I_c \frac{E_J}{(\varepsilon^2 + E_J^2)^{1/2}} \frac{N^{N-2}(N-1)}{2(N-2)!} \left(\frac{E_J}{2E_C} \right)^{N-2} \sin\varphi, \quad (12)$$

where ε is the energy difference between the Cooper pair states on the two islands of resonant transition. The current (12) at resonance scales as $(E_J/E_C)^{N-2}$, but since the transition region represents only a fraction of the pumping cycle on the order of E_J/E_C , the overall supercurrent contribution to the pumped charge (4) scales as $(E_J/E_C)^{N-1}$. This means that the inaccuracy is dominated by quantum tunneling of Cooper pairs [given by Eq. (10) or (11)] even with nonzero φ if the pumping is not too slow.

In conclusion, we have developed a quantitative theory of adiabatic Cooper pair transport in one-dimensional arrays of Josephson junctions. The theory predicts, among other things, that the quantum inaccuracy of the Cooper pair pumping in arrays with a small number of junctions is very large, a fact that can explain the lack of success of the experimental attempt¹³ to pump Cooper pairs.

This work was supported by AFOSR of the U.S. and the Academy of Finland (Project No. 40736).

¹H. Pothier, P. Lafarge, C. Urbina, D. Esteve, and M.H. Devoret, *Europhys. Lett.* **17**, 249 (1992).

²J.P. Pekola, A.B. Zorin, and M.A. Paalanen, *Phys. Rev. B* **50**, 11 255 (1994).

³M.W. Keller, J.M. Martinis, N.N. Zimmerman, and A.H. Steinbach, *Appl. Phys. Lett.* **69**, 1804 (1996); M.W. Keller, J.M. Martinis, and R.L. Kautz, *Phys. Rev. Lett.* **80**, 4530 (1998).

⁴L.P. Kouwenhoven, A.T. Johnson, N.C. van der Vaart, C.J.P.M. Harmans, and C.T. Foxon, *Phys. Rev. Lett.* **67**, 1626 (1991).

⁵V.I. Talyanskii, J.M. Shilton, M. Pepper, C.G. Smith, C.J.B. Ford, E.H. Linfield, D.A. Ritchie, and G.A.C. Jones, *Phys. Rev. B* **56**, 15 180 (1997).

⁶D.J. Thouless, *Phys. Rev. B* **27**, 6083 (1983).

⁷Q. Niu, *Phys. Rev. Lett.* **64**, 1812 (1990).

⁸H.D. Jensen and J.M. Martinis, *Phys. Rev. B* **46**, 13 407 (1992).

⁹D.V. Averin, A.A. Odintsov, and S.V. Vyshenskii, *J. Appl. Phys.* **73**, 1297 (1993).

¹⁰J.M. Martinis, M. Nahum, and H.D. Jensen, *Phys. Rev. Lett.* **72**, 904 (1994).

¹¹L.R.C. Fonseca, A.N. Korotkov, and K.K. Likharev, *Appl. Phys. Lett.* **69**, 1858 (1996).

¹²D.V. Averin, *Solid State Commun.* **105**, 659 (1998).

¹³L.J. Geerligs, S.M. Verbrugh, P. Hadley, J.E. Mooij, H. Pothier, P. Lafarge, C. Urbina, D. Esteve, and M.H. Devoret, *Z. Phys. B: Condens. Matter* **85**, 349 (1991).

¹⁴D.V. Averin and K.K. Likharev, in *Mesoscopic Phenomena in Solids*, edited by B.L. Altshuler, P.A. Lee, and R.A. Webb (Elsevier, Amsterdam, 1991).

¹⁵M.V. Berry, *Proc. R. Soc. London, Ser. A* **392**, 45 (1984).